

Nicolet Pro

Digital Oscilloscopes

Operation Manual

Test Instruments Division

5225 Verona Road/P.O. Box 4451 • Madison, Wisconsin 53744-4451 • 608/273-5008 • 800/356-8088
TWX: 910-286-2737 NICOLET MDS C • FAX: 608/273-5061

Nicolet
INSTRUMENTS OF DISCOVERY

P/N 269-911402

Nicolet Pro

Digital Oscilloscopes

Operation Manual

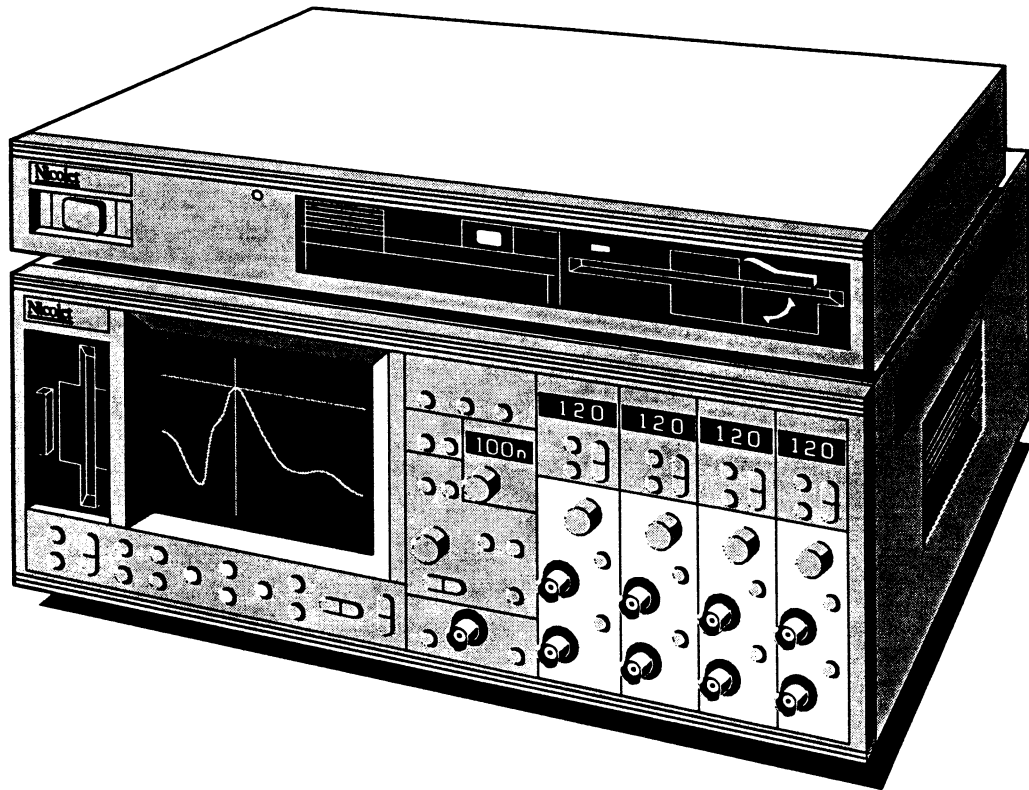

Nicolet Pro with Optional Pro Disk

Measurement Instruments Division

5225 Verona Road • Madison, Wisconsin 53711-4491 • 608/271-3333 • 800/356-8088

TWX: 910-286-2737 NICOLET MDS C • FAX: 608/273-5061

072693-3.0x

Nicolet
INSTRUMENTS OF DISCOVERY

NICOLET SYSTEM WARRANTY

Nicolet warrants that each product we sell you is free from defects in labor and materials and shall conform to its product specifications as defined in the product user documentation.

If the product does not function as warranted during the warranty period, we will repair or replace it without charge. If in our judgment we are unable to do so, you may return it to us and we will refund your money.

Warranty Period

The warranty period is stated in the product user documentation. If you install the product, the warranty period begins on the date of invoice. If we install the product, the warranty period begins on the date of installation but will begin no later than 30 days from the date of invoice.

The warranty period for products sold outside the U.S.A. and Canada is 12 months from the date of installation or 14 months from the date of shipment, whichever is less.

Limit of Warranty

Misuse, accident, modification, unsuitable physical or operating environment, improper maintenance, or damage caused by a product for which we are not responsible will void the warranty.

Certain components may have separate warranty periods as stated in the product user documentation. Consumables are not covered under warranty.

THIS WARRANTY REPLACES ALL OTHER WARRANTIES, EXPRESSED OR IMPLIED, INCLUDING THE IMPLIED WARRANTIES OF MERCHANTABILITY AND FITNESS FOR A PARTICULAR PURPOSE AND ANY OTHER OBLIGATIONS OR LIABILITIES ON THE PART OF NICOLET WHETHER IN CONTRACT, WARRANTY, NEGLIGENCE OR OTHERWISE. NICOLET SHALL NOT BE LIABLE FOR AND DISCLAIMS ALL CONSEQUENTIAL, INCIDENTAL AND CONTINGENT DAMAGES.

Items Not Covered by Warranty

We do not warrant uninterrupted or error-free operation of a product.

We provide certain non-Nicolet products on an "as is" basis. Non-Nicolet manufacturers or suppliers may provide their own warranties to you.

Separate software warranty is provided with software user documentation.

ABOUT THIS MANUAL

The information in this publication is provided for reference only. All information contained in this publication is believed to be correct and complete. Nicolet Instrument Corporation shall not be liable for errors contained herein nor for incidental or consequential damages in connection with the furnishing, performance, or the use of this material. All product specifications, as well as the information contained in this publication are subject to change without notice.

This publication may contain or reference information and products protected by copyrights or patents and does not convey any license under the patent rights of Nicolet Instrument Corporation, nor the rights of others. Nicolet Instrument Corporation does not assume any liability arising out of any infringements of patents or other rights of third parties.

Nicolet Instrument Corporation makes no warranty of any kind with regard to this material, including but not limited to, the implied warranties or merchantability and fitness for a particular purpose.

© 1991 by Nicolet Instrument Corporation, Madison, WI 53711. Printed in the United States of America. All world rights reserved. No part of this publication may be stored in a retrieval system, transmitted, or reproduced in any way, including but not limited to, photocopy, photograph, magnetic or other record, without the prior written permission of Nicolet Instrument Corporation.

Nicolet
INSTRUMENTS OF DISCOVERY

P/N 269-911400

Nicolet Pro

Digital Oscilloscopes

Operation Manual

Printed October 22, 1991

VERSION 3.0

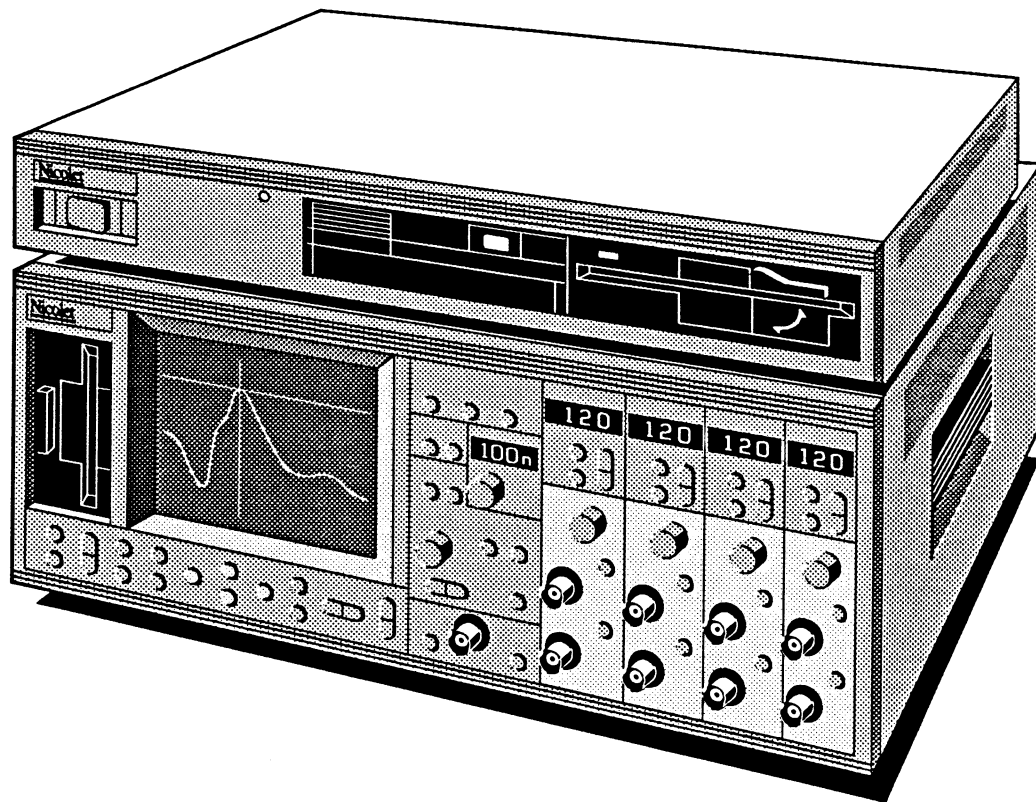

Test Instruments Division

5225 Verona Road • Madison, Wisconsin 53711-4491 • 608/271-3333 • 800/356-8088
TWX: 910-286-2737 NICOLET MDS C • FAX: 608/273-5061

Nicolet
INSTRUMENTS OF DISCOVERY

ABOUT THIS MANUAL

The information in this publication is provided for reference only. All information contained in this publication is believed to be correct and complete. Nicolet Instrument Corporation shall not be liable for errors contained herein nor for incidental or consequential damages in connection with the furnishing, performance, or the use of this material. All product specifications, as well as the information contained in this publication are subject to change without notice.

This publication may contain or reference information and products protected by copyrights or patents and does not convey any license under the patent rights of Nicolet Instrument Corporation, nor the rights of others. Nicolet Instrument Corporation does not assume any liability arising out of any infringements of patents or other rights of third parties.

Nicolet Instrument Corporation makes no warranty of any kind with regard to this material, including but not limited to, the implied warranties or merchantability and fitness for a particular purpose.

© 1991 by Nicolet Instrument Corporation, Madison, WI 53711. Printed in the United States of America. All world rights reserved. No part of this publication may be stored in a retrieval system, transmitted, or reproduced in any way, including but not limited to, photocopy, photograph, magnetic or other record, without the prior written permission of Nicolet Instrument Corporation.

WARRANTY

This Product is sold by Nicolet Instrument Corporation under the warranty herein set forth. The warranty is extended only to buyer purchasing the device directly from Nicolet Instrument Corporation, or as a new device from an authorized dealer.

Nicolet Instrument Corporation warrants this Product to be free from defects in workmanship and material under the normal use and service for a period of one (1) year from the date of delivery. The liability of Nicolet Instrument Corporation under this warranty is limited, at its sole discretion, to replacing, repairing or issuing credit (adjusted to reflect age and use of the Product) for a system or portion thereof returned to Nicolet Instrument Corporation during the warranty period, provided that (a) Nicolet Instrument Corporation is notified in writing within thirty (30) days following discovery of a defect by the buyer, (b) the defective device is returned to Nicolet Instrument Corporation, transportation charges prepaid by buyer, and (c) Nicolet Instrument Corporation's examination of the device shall disclose to its satisfaction that (i) the device has not been repaired or altered by anyone other than Nicolet Instrument Corporation, (ii) any defect has not been caused by misuse, neglect or accident, (iii) the device has not been operated under conditions other than normal use, and (iv) prescribed periodic maintenance and services have been performed with respect thereto.

THIS WARRANTY IS EXPRESSLY IN LIEU OF ALL OTHER WARRANTIES, EXPRESSED OR IMPLIED, WHETHER STATUTORY OR OTHERWISE, INCLUDING ANY IMPLIED WARRANTY OF MERCHANTABILITY OR FITNESS FOR A PARTICULAR PURPOSE. IN NO EVENT SHALL NICOLET INSTRUMENT CORPORATION BE LIABLE FOR ANY INCIDENTAL OR CONSEQUENTIAL DAMAGES RESULTING FROM THE USE OF THE PRODUCT OR CAUSED BY ANY DEFECT, FAILURE OR MALFUNCTION OF THE PRODUCT, WHETHER A CLAIM FOR SUCH DAMAGE IS BASED UPON WARRANTY, CONTRACT, NEGLIGENCE OR OTHERWISE.

Nicolet
INSTRUMENTS OF DISCOVERY

Chapter i

TABLE OF CONTENTS

Contents Listings _____	Page i-2	Front Panel Control Descriptions _____	See Below
Introduction _____	Chapter 1	Rear Panel Control Descriptions _____	Chapter 25
Warranty, Receiving & Inspection _____	Chapter 2	Waveform Data Files Specifications _____	Chapter 26
Warnings & Cautions _____	Chapter 3	Operating the Pro 90 & 92 Models _____	Chapter 27
Glossary of Terms _____	Chapter 4	Appendix _____	Chapter 28
Power Requirements _____	Chapter 5	Specifications _____	Chapter 29
Tutorial _____	Chapter 6	Index _____	Chapter 30

Quick Reference Guide

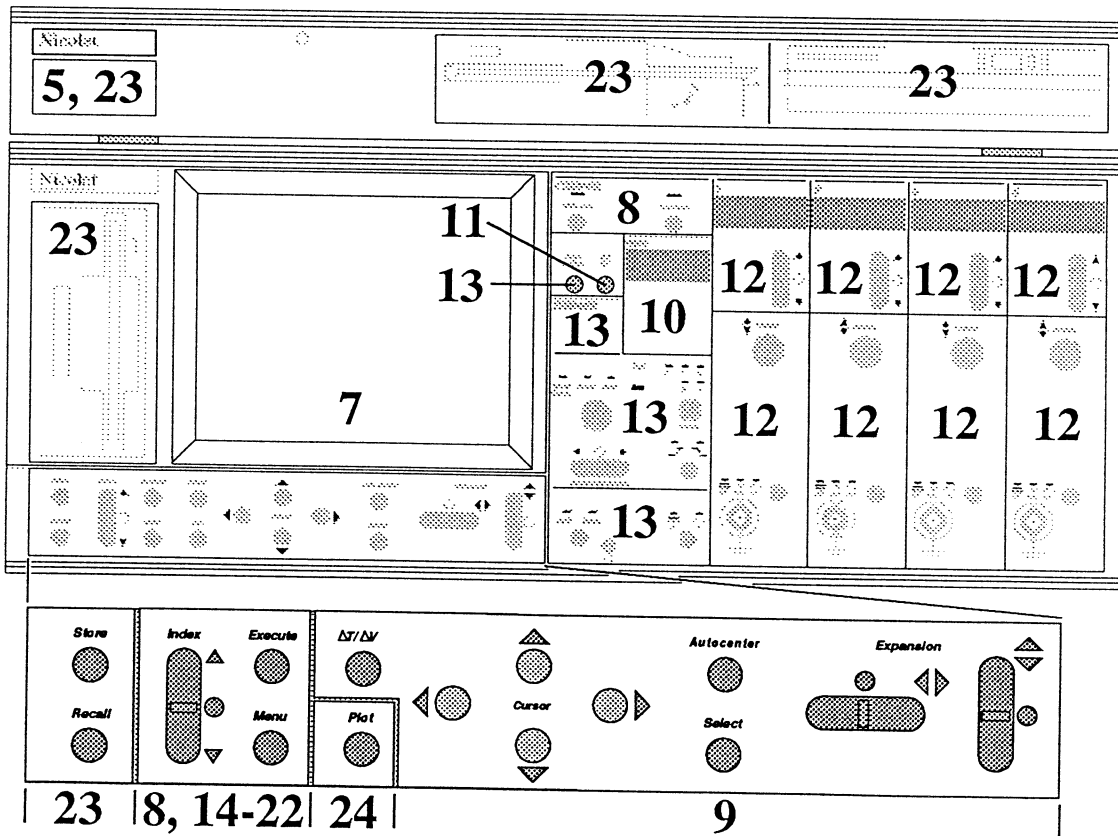

<p style="text-align: center;">Chapter 1 Introduction</p> <p>Describes the various Models and how to identify which digitizers are installed. Included is the Feature Highlights and instructions on how to reset the Pro Series digital oscilloscope if required.</p>	<p>The Various Models Available</p> <ul style="list-style-type: none"> • Pro 10, 20, 30, 32, 34, 40, 42, 44, 50, 60, 90 & 92 1-1 <p>Identifying the Digitizers 1-1</p> <p>Feature Highlights 1-3</p> <p>Resetting the Instrument 1-4</p>
<p style="text-align: center;">Chapter 2 Warranty, Receiving & Inspection</p>	<p>Includes the warranty and information about the receiving and inspection of your new Nicolet Pro Series digital oscilloscope.</p>
<p style="text-align: center;">Chapter 3 Warnings & Cautions</p>	<p>Lists Warnings and Cautions that you should be aware of while using your instrument. You should also follow all safety standards set by your place of employment.</p>
<p style="text-align: center;">Chapter 4 Glossary of Terms</p>	<p>Defines many of the terms used in this manual.</p>
<p style="text-align: center;">Chapter 5 Power Requirements</p>	<p>Contains the power requirements for the Pro Series and Pro Disk. It also includes power selections, fuse replacement and power interfacing between the Pro Series and Pro Disk.</p>
<p style="text-align: center;">Chapter 6 Tutorial</p>	<p>Provides step-by-step instructions that you can follow to become familiar with the basic operation of your instrument.</p>
<p style="text-align: center;">Chapter 7 The Display Screen</p>	<p>Briefly describes the basic display elements that appear on the screen.</p>

Chapter i

TABLE OF CONTENTS

<p>Contents Listings _____ Page i-2</p> <p>Introduction _____ Chapter 1</p> <p>Warranty, Receiving & Inspection _____ Chapter 2</p> <p>Warnings & Cautions _____ Chapter 3</p> <p>Glossary of Terms _____ Chapter 4</p> <p>Power Requirements _____ Chapter 5</p> <p>Tutorial _____ Chapter 6</p>	<p>Front Panel Control Descriptions _____ See Below</p> <p>Rear Panel Control Descriptions _____ Chapter 25</p> <p>Waveform Data Files Specifications _____ Chapter 26</p> <p>Operating the Pro 90 Model _____ Chapter 27</p> <p>Appendix _____ Chapter 28</p> <p>Specifications _____ Chapter 29</p> <p>Index _____ Chapter 30</p>
---	---

Quick Reference Guide

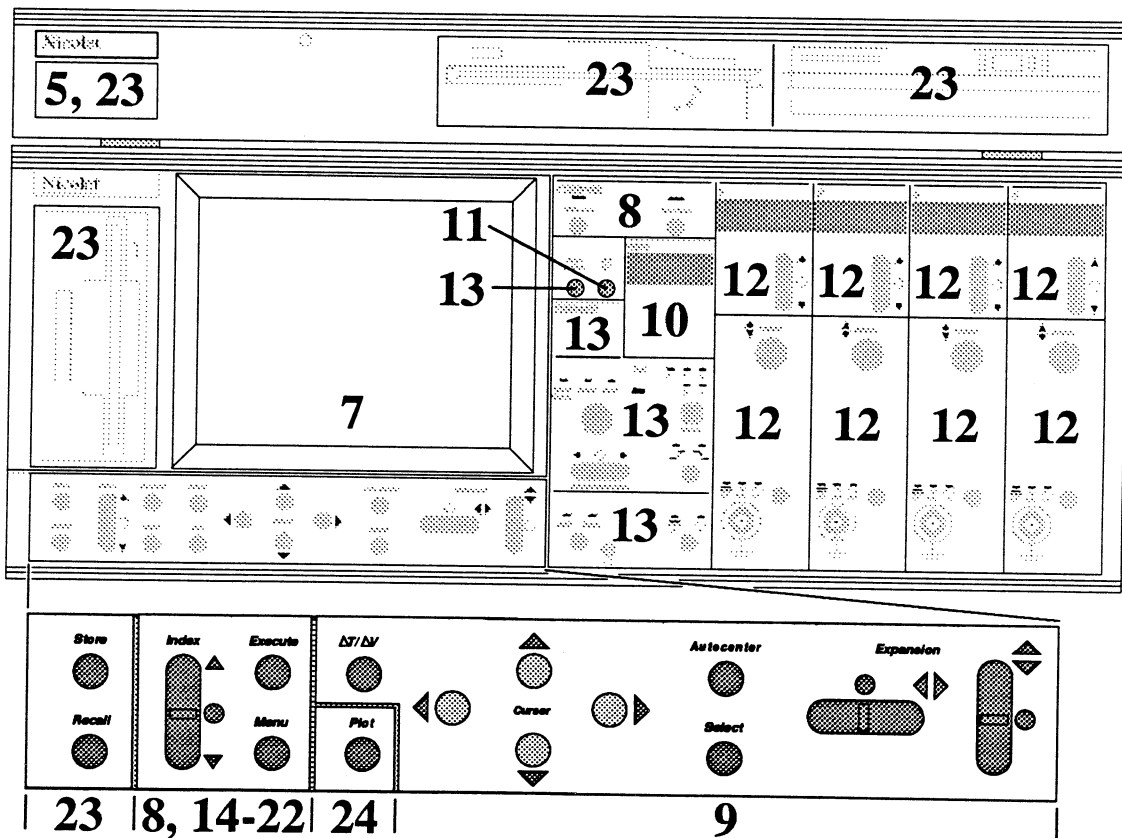

<p style="text-align: center;">Chapter 1 Introduction</p> <p>Describes the various Models and how to identify which digitizers are installed. Included is the Feature Highlights and instructions on how to reset the Pro Series digital oscilloscope if required.</p>	<p>The Various Models Available • Pro 10, 20, 30, 40, 50, 60 and 90 1-1</p> <p>Identifying the Digitizers 1-1</p> <p>Feature Highlights 1-3</p> <p>Resetting the Instrument 1-4</p>
<p style="text-align: center;">Chapter 2 Warranty, Receiving & Inspection</p>	<p>Includes the warranty and information about the receiving and inspection of your new Nicolet Pro Series digital oscilloscope.</p>
<p style="text-align: center;">Chapter 3 Warnings & Cautions</p>	<p>Lists Warnings and Cautions that you should be aware of while using your instrument. You should also follow all safety standards set by your place of employment.</p>
<p style="text-align: center;">Chapter 4 Glossary of Terms</p>	<p>Defines many of the terms used in this manual.</p>
<p style="text-align: center;">Chapter 5 Power Requirements</p>	<p>Contains the power requirements for the Pro Series and Pro Disk. It also includes power selections, fuse replacement and power interfacing between the Pro Series and Pro Disk.</p>
<p style="text-align: center;">Chapter 6 Tutorial</p>	<p>Provides step-by-step instructions that you can follow to become familiar with the basic operation of your instrument.</p>
<p style="text-align: center;">Chapter 7 The Display Screen</p>	<p>Briefly describes the basic display elements that appear on the screen.</p>

Chapter 8

The Storage Controls

Describes the controls and procedures that allow the instrument to capture "live" signals for display and store the digitized data in memory.

Live Button	8-3
Hold Last Button	8-4
Hold Next Button	8-5
The Hold Mode	8-6
Clearing the Status Line	8-6
Aborting a Long Sweep	8-6
Guarding Data Stored in Memory	8-6
The Sweep Review Memory	8-7

Chapter 9

The Display Controls

Describes the front panel controls which allow you to select data for inspections and expand the displayed data for closer inspections. It also describes how you can quickly perform comparative measurements between any two data points on the selected waveform by assigning one data point as a new time=0, volts=0 origin.

Left/Right Cursor Buttons	9-3
Selecting the Cursor Speed	9-6
Wrapping-Around Cursors	9-6
Up/Down Cursor Buttons	9-4
Selecting the Cursor Speed	9-6
Wrapping-Around Cursors	9-6
Introduction to Display Expansion	9-7
Setting the Expansion Defaults	9-7
More About the Expansion Marker	9-9
Inspecting Expanded Waveforms	9-10
Horizontal Expansion Button	9-11
Setting/Recalling the Expansion Defaults	9-13
Vertical Expansion Button	9-12
Setting/Recalling the Expansion Defaults	9-13
Autocenter Button	9-14
Moving the Cursors Independently of Each Other	9-15
Tracing the Waveform with the Crosshair	9-15
Moving the Waveform Through Screen Center	9-15
Select Button	9-16
Selecting a Different Waveform for Inspection	9-16
The Channel Identifier	9-16
$\Delta T/\Delta V$ Button	9-17
The $\Delta T/\Delta V$ Marker & Numerics	9-17
Selecting New Origins	9-17
Measuring $\Delta T/\Delta V$ Values	9-17

<h2 style="text-align: center;">Chapter 10</h2> <h3 style="text-align: center;">The Time Control</h3> <p>Describes the Time control which, along with the Sweep Length function, determines which samples taken from the analog input signal will be digitized for display on the screen. Also included in this chapter is a description of the external clock feature.</p>	<ul style="list-style-type: none"> Sampling the Signal 10-3 Varying the Time Per Point 10-4 Varying the Sweep Length 10-5 Setting the Sweep Length 10-8 Setting the Time Per Point 10-9 Calculating the Sweep Time 10-9 External Clock 10-10
<h2 style="text-align: center;">Chapter 11</h2> <h3 style="text-align: center;">The YT/XY Button</h3> <p>Describes how to display captured waveforms as voltage functions of time (YT Mode) or display one waveform as a function of another (XY Mode).</p>	<ul style="list-style-type: none"> The Y/T Display Mode 11-3 Inspecting Y/T Displays 11-3 Multiple Waveform Displays 11-3 The X/Y Display Mode 11-4 The XY Definition Screen 11-4 Defining the Axis' 11-5 Horizontal Expansion Off before Selecting XY 11-6 Expanding a Full XY Waveform Display 11-7 Horizontal Expansion On before Selecting XY 11-8 Expanding a Segmented XY Waveform Display 11-9
<h2 style="text-align: center;">Chapter 12</h2> <h3 style="text-align: center;">The Channel Controls</h3> <p>Describes the controls that determine the basic configuration of each individual channel. This chapter includes a description of the input amplifiers, how the input signals can be coupled to the amplifiers, and the input voltage range selector. Also included are descriptions on how to vertically reposition "live" signals, as well as how to save a waveform in memory for comparison with a "live" signal.</p>	<ul style="list-style-type: none"> Channel On/Off Button 12-3 Amplifier Input BNCs 12-3 Differential Amplifier Mode 12-3 Single-Ended Amplifier Mode 12-3 Coupling Buttons 12-4 Save Ref Button 12-4 Identifying a Save Reference Waveform 12-4 Save Referencing a Waveform 12-4 Volts Button 12-5 The Test Probes 12-5 Volts-Per-Level 12-5 Selecting the Volts Full Scale Range 12-6 Position Control 12-8

Chapter 13

The Trigger Controls

This chapter describes the trigger controls. Triggers are required to initiate sweeps with which the instrument captures information from the input signal for display on the screen.

See Chapter 18 for the advanced trigger modes available from the Trigger Menu.

Introduction	13-3
Auto/Norm Button	13-4
External Trigger Input BNC	13-4
External Trigger Coupling Button	13-4
Source Button	13-5
View Button	13-5
Auto Set-Up Button	13-5
Slope Button	13-6
Level Controls	13-7
Sensitivity Controls	13-8
Slope, Level and Sensitivity Summaries	13-9
Qualifying Successive Triggers	13-10
Stabilizing Recurrent Signal Displays	13-12
Setting Up Triggers	13-14
(+) or (-) Slope Triggers	13-14
Dual Slope Triggers	13-14
Single-Shot Triggers	13-15
Troubleshooting Trigger Problems	13-16
Horiz Trigger Position Button	13-17
The Various Sweep Modes	13-17
Increasing the Rate of Selection	13-17
The Trigger Markers	13-18
Data Trigger Marker	13-18
Setup Trigger Marker	13-18
The Trigger Default	13-18
Recalling the t=0 Default	13-18
Changing the t=0 Default	13-18
The Normal Sweep Mode	13-19
Reading Normal Sweep Displays	13-19
Reading Time with $\Delta T/\Delta V$ Turned On	13-20
The Mid Signal Trigger Mode	13-21
Reading Pre-trigger Sweep Displays	13-21
Reading Time with $\Delta T/\Delta V$ Turned On	13-22
Selecting Specific Amount of Pre-trigger Data	13-23
Selecting Pre-trigger Data While in Live	13-24
The Delayed Sweep Mode	13-25
Reading Delayed Sweep Displays	13-25
Reading Time with $\Delta T/\Delta V$ Turned On	13-26
Selecting a Specific Amount of Delay	13-27
Selecting Delayed Sweep Data While in Live	13-28
Deriving Triggers from a Single Source	13-29
Mixing Trigger Times and/or Sweep Modes	13-29
Status Button	13-30
Trgd LED	13-32
Arm LED	13-32
Compensation Point	13-32

Chapters 14 - 22

The Menu Controls

Describe the resident Menus and controls that are used to access the Functions.

General Information	Chapter 14	Display Functions	Chapter 19
Accessing the Menus	14-2	Cursor/Grid Options	19-2
Making Selections	14-3	Dot Join	19-3
Programs Functions	Chapter 15	User Units	19-4
FFT Snapshot	15-2	Channel Title	19-6
Recall Program	15-5	Print Screen	19-7
Clear All Programs	15-6	Max/Min	19-8
Learn Functions	Chapter 16	Disk Functions	Chapter 20
Start Learning	16-2	Store Setup	20-2
Stop Learning	16-4	Recall Setup	20-3
Execute Batch	16-4	Initialize MSO	20-4
• Aborting a Batch	16-4	Copy File	20-5
Store Batch	16-5	Delete File	20-6
Recall Batch	16-5	Format Disk	20-7
• Batches and the PC	16-6	Directory	20-8
• File Requirements	16-6	Plot From Disk	20-9
Print Batch	16-7	System Functions	Chapter 21
Acquisition Functions	Chapter 17	Setup To RAM	21-2
Sweep Length	17-2	Setup From RAM	21-2
Input Filters	17-4	I/O Parameters	21-3
Autocycle to Disk	17-5	Printer Output	21-4
Summation Average	17-9	Set Date/Time	21-5
Dual Sample Rates	17-10	Beeper	21-6
Trigger Functions	Chapter 18	High Res Auto Set-up	21-7
Glitch Triggering	18-3	About	21-8
Dropout Triggering	18-6	Tests Functions	Chapter 22
Hold Off Triggering	18-9	Front Panel Test	22-2
n-Event Triggering	18-12		
Adv Triggering	18-15		
Cursor Time Lock	18-19		
Independent Delays	18-21		
'OR' Triggering	18-22		
Level/Sens Lock	18-23		
Master/Slave	18-24		

Chapter 23

The Disk Drives

Describes the disk drives that are used to store and recall waveforms, store and recall front panel setups, copy files, and format new floppy diskettes.

Also included in this chapter is a description of the Pro Disk.

The Diskette Format	23-3
MS DOS Format	23-3
Reading Diskettes in an IBM- PC	23-3
The Drives, Directories & Waveform Files	23-4
The Pathname	23-4
The Operation	23-4
The Drive Specifier	23-4
The Root Directory	23-5
The Subdirectories	23-5
The Waveform File Name	23-5
Protecting Data on the Diskette	23-6
Loading the Diskette	23-6
Formatting New Diskettes	23-6
Storing Waveforms on Diskette	23-7
Initiating/Aborting the Store Mode	23-7
The Default File	23-8
Bypassing the Default File	23-8
Overwriting an Existing File	23-8
Single/Multiple Waveform Displays	23-9
The Store Procedure	23-10
Recalling Waveforms for Display	23-11
Selecting the Destination Channel	23-11
Initiating the Recall Mode	23-12
Selecting a File for Recall	23-12
Executing the Recall Mode	23-12
Aborting the Recall Mode	23-12
The Recall Procedure	23-12
The Pro Disk Option	23-13
Loading/Unloading the Floppy Disk	23-14
The Hard Drive	23-14
Loading/Unloading the Bernoulli Cartridge	23-15
Loading/Unloading the Optical Disk	23-16
Mounting the Pro Disk to the Pro Series	23-17

<p style="text-align: center;">Chapter 24 The Plotter Controls</p> <p>Describes how captured data can be output via the RS232 or IEEE ports at the rear of your instrument for hard copies.</p>	<p>Plotter Requirements 24-1</p> <p>RS232 Plotter Interface 24-3</p> <p>Setting Up the Plotter 24-3</p> <p>Interfacing the Scope 24-3</p> <p>IEEE-488 Plotter Interface 24-4</p> <p>Setting Up the Plotter 24-4</p> <p>Interfacing the Scope 24-4</p> <p>Aborting a Plot 24-4</p> <p>Executing a Plot 24-5</p> <p>The Change Plot Parameters Screen 24-6</p> <p>The Digital Plot Options Screen 24-7</p> <p>Plotting to Disk 24-8</p> <p>Point Labeling Waveforms 24-9</p> <p>Selecting Point Labels 24-9</p> <p>Executing the Point Label Plot 24-9</p>
<p style="text-align: center;">Chapter 25 The Rear Panel Controls</p> <p>This chapter describes each of the rear panel control functions. It also includes the recommended cabling.</p>	<p>Rear Panel Control Summaries 25-3</p> <p>The RS-232 Connector 25-4</p> <p>The IEEE-488 (GPIB) Connector 25-5</p> <p>Recommended Cables 25-6</p>
<p style="text-align: center;">Chapter 26 Waveform Data Files Specifications</p>	<p>This chapter contains both the Time Domain and Frequency Domain waveform data fields descriptions, including the normalization equations.</p>
<p style="text-align: center;">Chapter 27 Operating the Pro 90 & 92 Models</p>	<p>This chapter describes the Pro 90 and 92 operation when capturing data simultaneously with different sampling rates: Pro 90 - 8 bit, 200 MHz and 12 bit, 10 MHz digitizers; Pro 92 - 8 bit, 200 MHz and 12 bit, 20 MHz digitizer channels.</p>
<p style="text-align: center;">Chapter 28 Appendix</p>	<p>This chapter contains other useful information for your instrument.</p>
<p style="text-align: center;">Chapter 29 Specifications</p>	<p>This chapter contains the specifications for the Pro Series and each of the digitizers with which the instrument can be configured.</p>
<p style="text-align: center;">Chapter 30 Index</p>	

Chapter 23

The Disk Drives

Describes the disk drives that are used to store and recall waveforms, store and recall front panel setups, copy files, and format new floppy diskettes.

Also included in this chapter is a description of the Pro Disk.

The Diskette Format	23-3
MS DOS Format	23-3
Reading Diskettes in an IBM- PC	23-3
The Drives, Directories & Waveform Files	23-4
The Pathname	23-4
The Operation	23-4
The Drive Specifier	23-4
The Root Directory	23-5
The Subdirectories	23-5
The Waveform File Name	23-5
Protecting Data on the Diskette	23-6
Loading the Diskette	23-6
Formatting New Diskettes	23-6
Storing Waveforms on Diskette	23-7
Initiating/Aborting the Store Mode	23-7
The Default File	23-8
Bypassing the Default File	23-8
Overwriting an Existing File	23-8
Single/Multiple Waveform Displays	23-9
The Store Procedure	23-10
Recalling Waveforms for Display	23-11
Selecting the Destination Channel	23-11
Initiating the Recall Mode	23-12
Selecting a File for Recall	23-12
Executing the Recall Mode	23-12
Aborting the Recall Mode	23-12
The Recall Procedure	23-12
The Pro Disk Option	23-13
Loading/Unloading Diskettes/Bernoulli Cartridges	23-14
Mounting the Pro Disk to the Pro Series	23-15

<p style="text-align: center;">Chapter 24 The Plotter Controls</p> <p>Describes how captured data can be output via the RS232 or IEEE ports at the rear of your instrument for hard copies.</p>	<p>Plotter Requirements 24-1</p> <p>RS232 Plotter Interface 24-3</p> <p>Setting Up the Plotter 24-3</p> <p>Interfacing the Scope 24-3</p> <p>IEEE-488 Plotter Interface 24-4</p> <p>Setting Up the Plotter 24-4</p> <p>Interfacing the Scope 24-4</p> <p>Aborting a Plot 24-4</p> <p>Executing a Plot 24-5</p> <p>The Change Plot Parameters Screen 24-6</p> <p>The Digital Plot Options Screen 24-7</p> <p>Plotting to Disk 24-8</p> <p>Point Labeling Waveforms 24-9</p> <p>Selecting Point Labels 24-9</p> <p>Executing the Point Label Plot 24-9</p>
<p style="text-align: center;">Chapter 25 The Rear Panel Controls</p> <p>This chapter describes each of the rear panel control functions. It also includes the recommended cabling.</p>	<p>Rear Panel Control Summaries 25-3</p> <p>The RS-232 Connector 25-4</p> <p>The IEEE-488 (GPIB) Connector 25-5</p> <p>Recommended Cables 25-6</p>
<p style="text-align: center;">Chapter 26 Waveform Data Files Specifications</p>	<p>This chapter contains both the Time Domain and Frequency Domain waveform data fields descriptions, including the normalization equations.</p>
<p style="text-align: center;">Chapter 27 Operating the Pro 90 Model</p>	<p>This chapter describes the operation of the Pro 90 when capturing data simultaneously with the different sampling rates provided by the 8 bit, 200 MHz digitizer and 12 bit, 10 MHz digitizer channels.</p>
<p style="text-align: center;">Chapter 28 Appendix</p>	<p>This chapter contains other useful information for your instrument.</p>
<p style="text-align: center;">Chapter 29 Specifications</p>	<p>This chapter contains the specifications for the Pro Series and each of the digitizers with which the instrument can be configured.</p>
<p style="text-align: center;">Chapter 30 Index</p>	

Chapter 23

The Disk Drives

Describes the disk drives that are used to store and recall waveforms, store and recall front panel setups, copy files, and format new floppy diskettes.

Also included in this chapter is a description of the Pro Disk.

The Diskette Format	23-3
MS DOS Format	23-3
Reading Diskettes in an IBM- PC	23-3
The Drives, Directories & Waveform Files	23-4
The Pathname	23-4
The Operation	23-4
The Drive Specifier	23-4
The Root Directory	23-5
The Subdirectories	23-5
The Waveform File Name	23-5
Protecting Data on the Diskette	23-6
Loading the Diskette	23-6
Formatting New Diskettes	23-6
Storing Waveforms on Diskette	23-7
Initiating/Aborting the Store Mode	23-7
The Default File	23-8
Bypassing the Default File	23-8
Overwriting an Existing File	23-8
Single/Multiple Waveform Displays	23-9
The Store Procedure	23-10
Recalling Waveforms for Display	23-11
Selecting the Destination Channel	23-11
Initiating the Recall Mode	23-12
Selecting a File for Recall	23-12
Executing the Recall Mode	23-12
Aborting the Recall Mode	23-12
The Recall Procedure	23-12
The Pro Disk Option	23-13
Loading/Unloading Diskettes/Bernoulli Cartridges	23-14
Mounting the Pro Disk to the Pro Series	23-15

<p style="text-align: center;">Chapter 24 The Plotter Controls</p> <p>Describes how captured data can be output via the RS232 or IEEE ports at the rear of your instrument for hard copies.</p>	<p>Plotter Requirements 24-1</p> <p>RS232 Plotter Interface 24-3</p> <p>Setting Up the Plotter 24-3</p> <p>Interfacing the Scope 24-3</p> <p>IEEE-488 Plotter Interface 24-4</p> <p>Setting Up the Plotter 24-4</p> <p>Interfacing the Scope 24-4</p> <p>Aborting a Plot 24-4</p> <p>Executing a Plot 24-5</p> <p>The Change Plot Parameters Screen 24-6</p> <p>The Digital Plot Options Screen 24-7</p> <p>Plotting to Disk 24-8</p> <p>Point Labeling Waveforms 24-9</p> <p>Selecting Point Labels 24-9</p> <p>Executing the Point Label Plot 24-9</p>
<p style="text-align: center;">Chapter 25 The Rear Panel Controls</p> <p>This chapter describes each of the rear panel control functions. It also includes the recommended cabling.</p>	<p>Rear Panel Control Summaries 25-3</p> <p>The RS-232 Connector 25-4</p> <p>The IEEE-488 (GPIB) Connector 25-5</p> <p>Recommended Cables 25-6</p>
<p style="text-align: center;">Chapter 26 Waveform Data Files Specifications</p>	<p>This chapter contains both the Time Domain and Frequency Domain waveform data fields descriptions, including the normalization equations.</p>
<p style="text-align: center;">Chapter 27 Operating the Pro 90 & 92 Models</p>	<p>This chapter describes the Pro 90 and 92 operation when capturing data simultaneously with different sampling rates: Pro 90 - 8 bit, 200 MHz and 12 bit, 10 MHz digitizers; Pro 92 - 8 bit, 200 MHz and 12 bit, 20 MHz digitizer channels.</p>
<p style="text-align: center;">Chapter 28 Appendix</p>	<p>This chapter contains other useful information for your instrument.</p>
<p style="text-align: center;">Chapter 29 Specifications</p>	<p>This chapter contains the specifications for the Pro Series and each of the digitizers with which the instrument can be configured.</p>
<p style="text-align: center;">Chapter 30 Index</p>	

Chapter 1

INTRODUCTION

This manual describes the following Nicolet Pro Models

- Pro 10 - two channel, 12 bit, 1 MegaSamples Per Second digitizers.
- Pro 20 - four channel, 12 bit, 1 MegaSamples Per Second digitizers.
- Pro 30 - two channel, 12 bit, 10 MegaSamples Per Second digitizers.
- Pro 32 - two channel, 12 bit, 20 MegaSamples Per Second digitizers.
- Pro 34 - four channel, 12 bit, 20 MegaSamples Per Second digitizers.
- Pro 40 - four channel, 12 bit, 10 MegaSamples Per Second digitizers.
- Pro 42 - two channel, 14 bit, 5 MegaSamples Per Second digitizers.
- Pro 44 - four channel, 14 bit, 5 MegaSamples Per Second digitizers.
- Pro 50 - two channel, 8 bit, 200 MegaSamples Per Second digitizers.
- Pro 60 - four channel, 8 bit, 200 MegaSamples Per Second digitizers.
- Pro 90 - two 12 bit, 10 MS/s digitizers and two 8 bit, 200 MS/s digitizers.
- Pro 92 - two 12 bit, 20 MS/s digitizers and two 8 bit, 200 MS/s digitizers.

See page 1-2 for instructions to identify which digitizers are installed in your model.

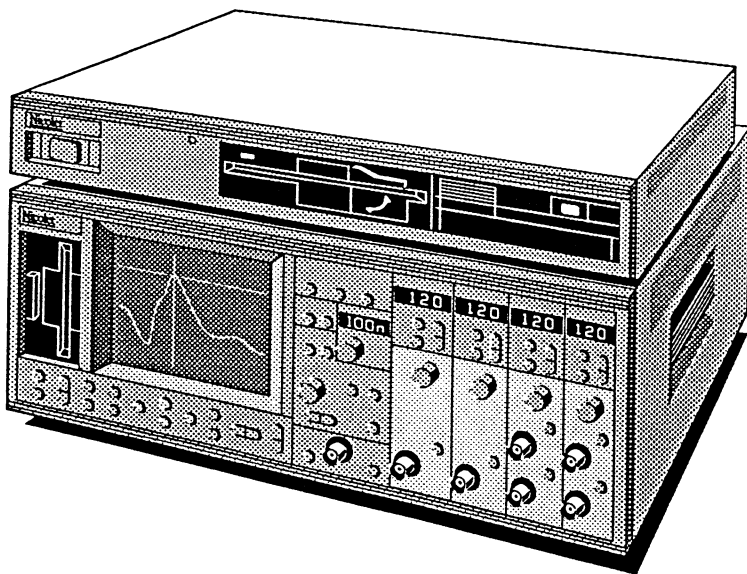

Nicolet Pro 90 Model with two 8 bit, 200 MS/s digitizers and two 12 bit, 10 MS/s digitizers

Your new Nicolet Pro Series digital oscilloscope allows you to digitize analog input signals, store the digitized signals in memory and view them on the display screen. The displayed waveforms can then be used to measure time and voltage values (or any other units you assign to the numeric readouts), manipulate the waveforms either internally in the Pro series or send it to an external computer, return it to the instrument for additional inspections and then send it to a printer for a hard copy.

The major operational differences between the digitizers are the sampling rates (Time-per-point) and the voltage levels (Volts range). These differences are brought to your attention when applicable. The examples in this manual typically use the 12 bit, 10 MS/s digitizers.

Important: Also see *Chapter 27* when using the *Pro 90* or *92* Models for additional operating instructions and considerations.

IDENTIFYING THE DIGITIZERS

WARNING: See Chapter 5 to verify correct voltage settings before continuing.

To identify which digitizers are installed in your instrument, apply power to the instrument and turn off all of the channels to view the About screen. You can also access the About screen via the front panel MENU button. See the About function in Chapter 21.

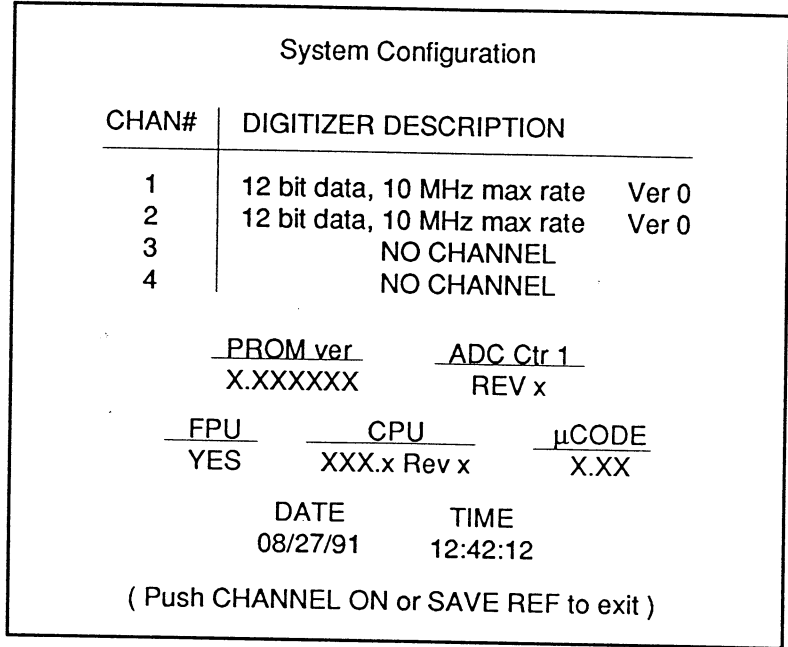

Figure 1 - An example About screen of an Pro 30 Model which is comprised of two 12 bit, 10 MHz digitizers.

- Two channel 12 bit, 1 MegaSamples Per Second digitizers.....Pro 10 Model
- Four channel, 12 bit, 1 MegaSamples Per Second digitizers.....Pro 20 Model
- Two channel, 12 bit, 10 MegaSamples Per Second digitizers.....Pro 30 Model
- Two channel, 12 bit, 20 MegaSamples Per Second digitizers.....Pro 32 Model
- Four channel, 12 bit, 20 MegaSamples Per Second digitizers.....Pro 34 Model
- Four channel, 12 bit, 10 MegaSamples Per Second digitizers.....Pro 40 Model
- Two channel, 14 bit, 5 MegaSamples Per Second digitizers.....Pro 42 Model
- Four channel, 14 bit, 5 MegaSamples Per Second digitizers.....Pro 44 Model
- Two channel, 8 bit, 200 MegaSamples Per Second digitizers.....Pro 50 Model
- Four channel, 8 bit, 200 MegaSamples Per Second digitizers.....Pro 60 Model
- Two 12 bit, 10 MS/s digitizers and two 8 bit, 200 MS/s digitizers.....Pro 90 Model
- Two 12 bit, 20 MS/s digitizers and two 8 bit, 200 MS/s digitizers.....Pro 92 Model

Chapter 1

INTRODUCTION

This manual describes the following Nicolet Pro Models

- Pro 10** - two channel, 12 bit, 1 MegaSamples Per Second digitizers.
- Pro 20** - four channel, 12 bit, 1 MegaSamples Per Second digitizers.
- Pro 30** - two channel, 12 bit, 10 MegaSamples Per Second digitizers.
- Pro 40** - four channel, 12 bit, 10 MegaSamples Per Second digitizers.
- Pro 50** - two channel, 8 bit, 200 MegaSamples Per Second digitizers.
- Pro 60** - four channel, 8 bit, 200 MegaSamples Per Second digitizers.
- Pro 90** - two 12 bit, 10 MS/s digitizers and two 8 bit, 200 MS/s digitizers.

See *page 1-2* for instructions to identify which digitizers are installed in your model.

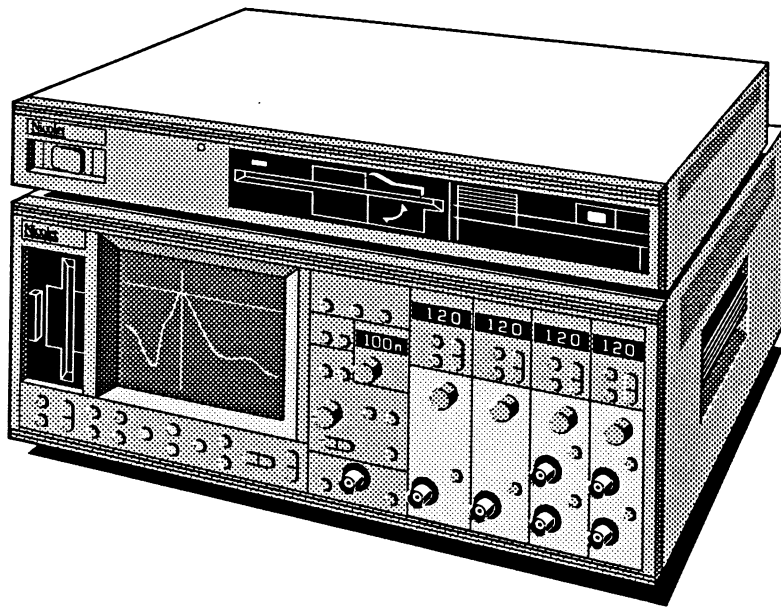

Nicolet Pro 90 Model with two 8 bit, 200 MS/s digitizers and two 12 bit, 10 MS/s digitizers

Your new Nicolet Pro Series digital oscilloscope allows you to digitize analog input signals, store the digitized signals in memory and view them on the display screen. The displayed waveforms can then be used to measure time and voltage values (or any other units you assign to the numeric readouts), manipulate the waveforms either internally in the Pro series or send it to an external computer, return it to the instrument for additional inspections and then send it to a printer for a hard copy.

The major operational differences between the digitizers are the sampling rates (Time-per-point) and the voltage levels (Volts range). These differences are brought to your attention when applicable. The examples in this manual typically use the 12 bit, 10 MS/s digitizers.

Important: Also see *Chapter 27* when using the **Pro 90** Model for additional operating instructions and considerations.

IDENTIFYING THE DIGITIZERS

WARNING: See *Chapter 5* to verify correct voltage settings before continuing.

To identify which digitizers are installed in your instrument, apply power to the instrument and turn off all of the channels to view the About screen. You can also access the About screen via the front panel MENU button. See the About function in *Chapter 21*.

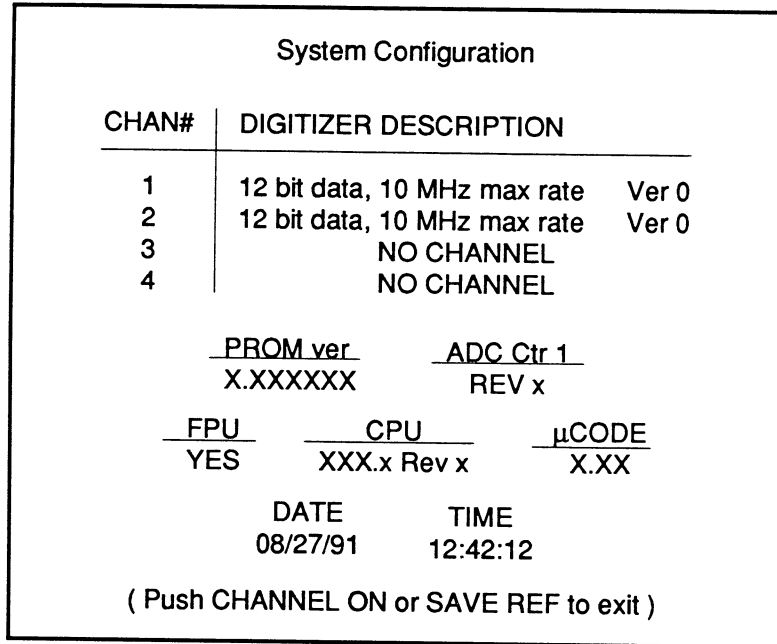

Figure 1 - An example About screen of an Pro 30 Model which is comprised of two 12 bit, 10 MHz digitizers.

- Two channel 12 bit, 1 MegaSamples Per Second digitizers.....Pro 10 Model
- Four channel, 12 bit, 1 MegaSamples Per Second digitizers.....Pro 20 Model
- Two channel, 12 bit, 10 MegaSamples Per Second digitizers.....Pro 30 Model
- Four channel, 12 bit, 10 MegaSamples Per Second digitizers.....Pro 40 Model
- Two channel, 8 bit, 200 MegaSamples Per Second digitizers.....Pro 50 Model
- Four channel, 8 bit, 200 MegaSamples Per Second digitizers.....Pro 60 Model
- Two 12 bit, 10 MS/s digitizers and two 8 bit, 200 MS/s digitizers.....Pro 90 Model

FEATURE HIGHLIGHTS

Your Pro instrument has many useful features that will become obvious as you experiment with your instrument. There are many features that you may not become aware of unless you read this manual thoroughly.

In case you haven't the time to read the entire manual, some of the important features that you should be aware of and use are highlighted on this page. It would be beneficial, however, to take the time and go through the **Tutorial** located in chapter 6.

Battery Backup

Also see chapter 5.

Your Pro instrument has a backup battery. The instrument returns to its last front panel settings and any downloaded programs stored in memory are retained if power is interrupted and then applied again.

Sweep Review Memory

Also see chapter 8.

The Sweep Review Memory maintains an archive of past sweeps which can be recalled quickly for display by pressing the Index button. When the memory is full, the oldest sweep is discarded to make room for the newest sweep. Press the middle of the Index button to return to the current display.

Advanced Triggering Functions

Also see chapter 19.

Several advanced triggering functions are available through the Trigger menu; Glitch, Dropout, Hold Off and n Event, as well as advanced versions.

The Cursor Buttons

Also see chapter 9.

Pressing the Left and Right Cursor buttons simultaneously moves the vertical cursor to the trigger ($t=0$) coordinate. Likewise, pressing the Up and Down Cursor buttons simultaneously moves the horizontal cursor to the digital zero ($v=0$) coordinate.

Pressing the Up and either Left or Right Cursor buttons simultaneously moves the crosshair to the next peak on a continuously sloping sine or triangle waveform while in the HOLD mode. Pressing the Down and either Left or Right Cursor buttons simultaneously moves the crosshair to the next valley of a continuously sloping sine or triangle waveform while in the HOLD mode.

The Sweep Length

Also see chapter 10.

The Sweep Length function allows you to select longer record lengths captured at a lower time-per-point setting. This provides increased time resolution of the captured signal when the captured data is horizontally expanded.

Save Reference

Also see chapter 12.

The Save Reference feature allows you to capture a signal on one channel, save that waveform and then capture a second signal in the Live mode for comparison. This is particularly beneficial when performing comparison acquisitions because both signals will have been captured under identical conditions.

Auto Set-up Function

Also see chapter 13.

Once a repetitive input signal has been properly coupled and the instrument is operating in the LIVE mode, pressing the Auto Set-up button allows the instrument to automatically evaluate various front panel settings and set them to the optimum values to capture and display the signal. You then can adjust the various trigger controls accordingly for your particular application.

Resident Menu Functions

Also see chapters 14 - 22.

The instrument has many resident functions which you can use to determine how data will be captured and displayed for inspection; as well as many other functions used to control the operation of your instrument.

The Disk Drive(s)

Also see chapter 23.

The instrument comes with an internal floppy drive which allows you to store data for later recall. The Pro Disk option allows additional storage mediums (3.5" or 5.25" floppy drives, fixed hard disk or removable cartridge).

Other Features

These are only a few of the many features available for your use. As you become familiar with your instrument and review this manual, you will discover many of the other features.

RESETTING THE INSTRUMENT

If your instrument should become disorientated or you want to interrupt a long process such as exporting a large waveform file to an external device, there are two methods you can use.

Method #1

Use this method to reset the interfaces such as when you wish to stop exporting a large file to an external device. This method is also helpful to break out of a looping batch file. All front panel memory and function parameters remain at their current settings.

With power still applied to the instrument,

1. Press and hold the HOLD LAST button.
2. Press the EXECUTE button.
3. Release the HOLD LAST button.

A ***DEVICE CLEAR*** message will appear on the screen. To clear this message, press the HOLD LAST button.

Method #2

This method resets all of the front panel memory and function parameters to the factory defaults and nulls all data stored in memory. This method should be used only if the instrument becomes disorientated or you wish to return the instrument to its factory default settings.

CAUTION: This method nulls all data stored in memory.

1. Remove power from the instrument.
2. Press and hold the EXECUTE button.
3. Apply power to the instrument.
4. Release the EXECUTE button.

Chapter 2

WARRANTY, RECEIVING and INSPECTION

WARRANTY

This Product is sold by Nicolet Instrument Corporation under the warranty herein set forth. The warranty is extended only to the buyer purchasing the device directly from Nicolet Instrument Corporation or as a new device from an authorized dealer or distributor of Nicolet Instrument Corporation.

Nicolet Instrument Corporation warrants this Product to be free from defects in workmanship and material under normal use and service and shall conform to the description thereof contained in this brochure for a period of one (1) year from the date of delivery. The liability of Nicolet Instrument Corporation under this warranty is limited, at its sole discretion, to replacing, repairing or issuing credit (adjusted to reflect age and use of the Product) for a system or portion thereof returned to Nicolet Instrument

Corporation during the warranty period, provided that

- (a) Nicolet Instrument Corporation is notified in writing within thirty (30) days following discovery of a defect by the buyer,
- (b) the defective device is returned to Nicolet Instrument Corporation, transportation charges prepaid by buyer, and
- (c) Nicolet Instrument Corporation's examination of the device shall disclose to its satisfaction that
 - (i) the device has not been repaired or altered by anyone other than Nicolet Instrument Corporation,
 - (ii) any defect has not been caused by misuse, neglect or accident,
 - (iii) the device has not been operated under conditions other than normal use, and
 - (iv) prescribed periodic maintenance and services have been performed with respect thereto.

THIS WARRANTY IS EXPRESSLY IN LIEU OF ALL OTHER WARRANTIES, EXPRESSED OR IMPLIED, WHETHER STATUTORY OR OTHERWISE, INCLUDING ANY IMPLIED WARRANTY OF MERCHANTABILITY OR FITNESS FOR A PARTICULAR PURPOSE. IN NO EVENT SHALL NICOLET INSTRUMENT CORPORATION BE LIABLE FOR ANY INCIDENTAL OR CONSEQUENTIAL DAMAGES RESULTING FROM THE USE OF THE PRODUCT OR CAUSED BY ANY DEFECT, FAILURE OR MALFUNCTION OF THE PRODUCT, WHETHER A CLAIM FOR SUCH DAMAGE IS BASED UPON WARRANTY, CONTRACT, NEGLIGENCE OR OTHERWISE.

NOTE: For G.S.A. customers, (U.S. only) the standard G.S.A. 1 year warranty applies.

RECEIVING

Unpack the instrument and save the carton and packing material in case the instrument must be shipped to another site or returned to the factory for service.

INSPECTION

Inspect the exterior of the instrument for any visible signs of damage that may have occurred during transit.

If damaged, contact -

Nicolet Instrument Corporation

Shipping Department
5225 Verona Road/P.O. Box 4451
Madison, Wisconsin 53711-4495
Telephone 608/271-3333
TWX: 910-286-2736 NICOLET MDS B
FAX: 608/273-5046

Outside the U.S., call your local Nicolet office or distributor.

Chapter 3

WARNINGS

and CAUTIONS

The first WARNING note below is required by the FCC and relates only to the interference potential of this equipment. This message is a direct quotation.

⚠ WARNING: The equipment generates, uses, and can radiate radio frequency energy and if not installed and used in accordance with the instructions manual, may cause interference to radio communications. As temporarily permitted by regulation, it has not been tested for compliance with the limits for Class A computing devices pursuant to Subpart J or Part 15 of FCC Rules, which are designed to provide reasonable protection against such interference. Operation of this equipment in a residential area is likely to cause interference in which case the user at his own expense will be required to take whatever measures may be required to correct the interference.

This apparatus has been designed in accordance with IEC Publication 348, UL 1244, safety Requirements for Electronic Measuring Apparatus, and has been supplied in a safe condition. The present instruction manual contains some information and warnings which have to be followed by the user to ensure safe operation and to retain the apparatus in safe condition.

The apparatus has been designed for indoor use. It may occasionally be subjected to temperatures between 0°C and +50°C without degradation of its safety.

The mains plug shall only be inserted in a socket provided with a protective earth contact. The protective action must not be negated by the use of an extension cord without a protective conductor.

WARNING!

⚠ Any interruption of the protective conductor inside or outside the apparatus or disconnection of the protective earth terminal is likely to make the apparatus dangerous. Intentional interruption is prohibited.

⚠ When the apparatus is connected to its supply, terminals may be live, and the opening of covers or removal of parts (except those to which access can be gained by hand) is likely to expose live parts.

The apparatus shall be disconnected from all voltage sources before it is opened for any adjustment, replacement, maintenance or repair.

Capacitors inside the apparatus may still be charged even if the apparatus has been disconnected from all voltage sources.

Any adjustment, maintenance and repair of the opened apparatus under voltage shall be avoided as far as possible and, if inevitable, shall be carried out only by a skilled person who is aware of the hazard involved.

Make sure that only fuses with the required rated current and of the specified type are used for replacement. The use of makeshift fuses and the short-circuiting of fuse holders are prohibited.

⚠ Whenever it is likely that the protection has been impaired, the apparatus shall be made inoperative and be secured against any unintended operation.

The protection is likely to be impaired if, for example, the apparatus shows visible damage or has been subjected to severe transport stresses.

Electrical shock hazard. Do not remove covers. Refer servicing to qualified individuals.

Proper use of this device depends on careful reading of all instructions and labels.

⚠ WARNING: This instrument and related accessories are not designed for biomedical experiments on humans and should not be directly connected to human subjects.

⚠ WARNING: This instrument must not be operated in explosive atmospheres.

⚠ WARNING: Inspect the voltage selector (Figure 5-1) at the rear of this instrument for the correct setting before applying power.

⚠ WARNING: Never operate this instrument in the vertical, upright position (resting on its rear panel) or the instrument may overheat from improper air circulation.

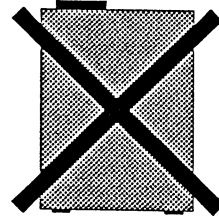

⚠ CAUTION: Refer to *Chapter 5, page 5-1 (Power Requirements)* before applying power to this instrument.

⚠ CAUTION: Always ensure that the input signal does not exceed the maximum allowable input voltage, with respect to ground, listed in the specifications located at the rear of this manual.

Chapter 3

WARNINGS

and CAUTIONS

The first WARNING note below is required by the FCC and relates only to the interference potential of this equipment. This message is a direct quotation. Although stated as a “warning,” there is essentially no risk of injury, loss of life, or equipment damage.

⚠ WARNING: The equipment generates, uses, and can radiate radio frequency energy and if not installed and used in accordance with the instructions manual, may cause interference to radio communications. As temporarily permitted by regulation, it has not been tested for compliance with the limits for Class A computing devices pursuant to Subpart J or Part 15 of FCC Rules, which are designed to provide reasonable protection against such interference. Operation of this equipment in a residential area is likely to cause interference in which case the user at his own expense will be required to take whatever measures may be required to correct the interference.

This apparatus has been designed in accordance with IEC Publication 348, UL 1244, safety Requirements for Electronic Measuring Apparatus, and has been supplied in a safe condition. The present instruction manual contains some information and warnings which have to be followed by the user to ensure safe operation and to retain the apparatus in safe condition.

The apparatus has been designed for indoor use. It may occasionally be subjected to temperatures between 0°C and +50°C without degradation of its safety.

The mains plug shall only be inserted in a socket provided with a protective earth contact. The protective action must not be negated by the use of an extension cord without a protective conductor.

WARNING!

⚠ Any interruption of the protective conductor inside or outside the apparatus or disconnection of the protective earth terminal is likely to make the apparatus dangerous. Intentional interruption is prohibited.

⚠ When the apparatus is connected to its supply, terminals may be live, and the opening of covers or removal of parts (except those to which access can be gained by hand) is likely to expose live parts.

The apparatus shall be disconnected from all voltage sources before it is opened for any adjustment, replacement, maintenance or repair.

Capacitors inside the apparatus may still be charged even if the apparatus has been disconnected from all voltage sources.

Any adjustment, maintenance and repair of the opened apparatus under voltage shall be avoided as far as possible and, if inevitable, shall be carried out only by a skilled person who is aware of the hazard involved.

Make sure that only fuses with the required rated current and of the specified type are used for replacement. The use of makeshift fuses and the short-circuiting of fuse holders are prohibited.

⚠ Whenever it is likely that the protection has been impaired, the apparatus shall be made inoperative and be secured against any unintended operation.

The protection is likely to be impaired if, for example, the apparatus shows visible damage or has been subjected to severe transport stresses.

Electrical shock hazard. Do not remove covers. Refer servicing to qualified individuals.

Proper use of this device depends on careful reading of all instructions and labels.

⚠ WARNING: This instrument and related accessories are not designed for biomedical experiments on humans and should not be directly connected to human subjects.

⚠ WARNING: This instrument must not be operated in explosive atmospheres.

⚠ WARNING: Inspect the voltage selector (Figure 5-1) at the rear of this instrument for the correct setting before applying power.

⚠ WARNING: Never operate this instrument in the vertical, upright position (resting on its rear panel) or the instrument may overheat from improper air circulation.

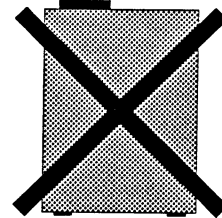

⚠ CAUTION: Refer to *Chapter 5, page 5-1 (Power Requirements)* before applying power to this instrument.

⚠ CAUTION: Always ensure that the input signal does not exceed the maximum allowable input voltage, with respect to ground, listed in the specifications located at the rear of this manual.

Chapter 4

GLOSSARY

OF TERMS

Abort Mode:	Activated by pressing in and holding the Hold button while tapping the Live button. Aborts a sweep already in progress, storing any data already acquired before the abort.	Controller:	A device connected to an interface which commands other devices on the interface.
Acquire:	The process of digitizing the analog input signal and displaying the resultant waveform.	Data Points:	Small dots representing the discrete, digitized time and voltage coordinates of the analog input signal.
Address:	A number which represents a device attached to the GPIB.	Data Set:	See Modem.
ASCII:	American Standard Code for Information Interchange. A seven bit system of representing characters such as numbers, letters, math symbols, etc.	Digitizer:	Converts analog input signals into discrete, digitized time and voltage values.
Baud:	Bit serial data transmission rate measured in bits per second.	Delimiter:	ASCII character(s) used to separate or end strings of characters which belong together as a group. Carriage Return (CR) and Linefeed (LF) are common examples.
Bit:	Synonym for a binary digit which can be either a logic level one (1, or mark) or a logic level zero (0, or space).	DIP:	Dual In-line Package. Standard physical structure of integrated circuits. Two rows of pins are attached to the IC body.
Bit Serial:	Data is sent one bit at a time. RS-232 communications are bit serial.	End Of File (EOF):	A delimiter that indicates the end of data transmission.
BNC:	Input and/or output connector.	Full Duplex:	RS-232 communications that can travel in two directions simultaneously.
Bus:	Wires used to send groups of bits. Buses can be internal or external to a machine.	GPIB:	General Purpose Interface Bus. Specified by IEEE-488.
Byte:	A group of eight bits.	HPIB:	Hewlett Packard Interface Bus. Essentially the same as the GPIB/IEEE-488. Devices with the HPIB are compatible with the IEEE-488.
Carriage Return:	A computer terminal key which causes the printing head or cursor to return to the start of the line.	Half Duplex:	RS-232 communications that pass in only one direction at any given time.
Character:	Standard symbols such as: A-Z, a-z, 0-9, +, -, etc.		

Handshaking:	The process of synchronizing communications between devices. A system of questions (Ready?) and replies (Yes!) are used to make sure sender and receiver are properly prepared.	Modem:	Modulator-demodulator. An RS-232 device used to send and receive binary data on telephone lines. Each binary "1" or "0" is represented with a specific signal frequency.
Hold Last Mode:	Activated by pressing the HOLD button while operating in the Live Mode. Stores data acquired since the <u>last</u> valid trigger in the memory.	Negative Logic:	A low voltage represents a binary "1." This is the convention used by the IEEE-488 and RS-232 data transmission lines.
Hold Mode:	A term used to describe the status of the instrument when the Hold Last LED is on and the Live LED is off.	Noise:	Undesirable voltage disturbances on the input signal.
Hold Next Mode:	Activated by pressing the HOLD NEXT button. Stores data captured after the <u>next</u> valid trigger initiates a sweep.	Numerics:	The alphanumeric readouts on the display screen.
IEEE-488:	The IEEE specification for the GPIB.	Parity Bit:	A parity bit is an extra bit added to a binary word to create an even or odd number of binary bits equal to "1." By counting the number of 1's in a word and knowing whether the total should be even or odd, the receiving device can detect most errors due to interface noise. Used with RS-232 interfacing.
I/O:	Input/Output.	Positive Logic:	A high voltage represents a binary "1." This is the convention used by RS-232 handshaking lines.
Interface:	The circuitry and programming necessary for the interconnection of electronic devices.	Read:	The process of taking stored data from a diskette record and placing it into the display memory for display on the screen.
LED:	Light emitting diode used as a status light.	Record Separator:	A delimiter that separates data values in a transmission.
Live Mode:	Activated by pressing the LIVE button. Enables valid triggers to continuously trigger new sweeps.	Resolution:	The discernible voltage difference between the individual data points of a digitized signal. At high resolution the discernible difference is so slight that the digital signal has the characteristics of the analog signal.
LSB:	Least Significant Bit. The bit in the lowest binary location in a binary number.	RS-232:	Recommended Standard 232. An EIA specification which defines bit serial data communications.
Line Feed:	A computer terminal key that causes the paper or cursor to advance one line.		
MSB:	Most Significant Bit. The bit in the highest binary location in a binary number.		
Memory:	Device used to temporarily record digitized input signals.		

Serial Data: See Bit Serial.

Start Bit: A bit which precedes the eight bits (7 bits plus parity bit) representing an ASCII character. The start bit is a warning to the receiver that data will follow immediately. Start bits are at logic "00." Start bits are used with RS-232 communications.

Stop Bit: The bit(s) that immediately follow the eight bits (7 bits plus parity bit) that compose an ASCII character. The stop bits (1 or 2) define the minimum spacing between characters. Stop bits are at logic "11." Stop bits are used with RS-232 communications.

Sweep:

The acquisition and display of the analog input signal. Initiated after a valid trigger has occurred.

Trigger:

A signal which meets all of the requirements to initiate a sweep.

Turnaround Delay: This is the minimum amount of time that the System has to wait after receiving a command that requires a

Chapter 5 POWER REQUIREMENTS

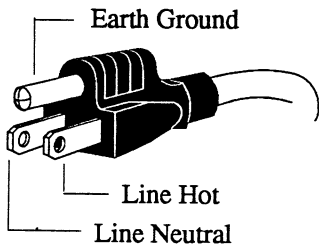

Figure 1 - Male Power Connector

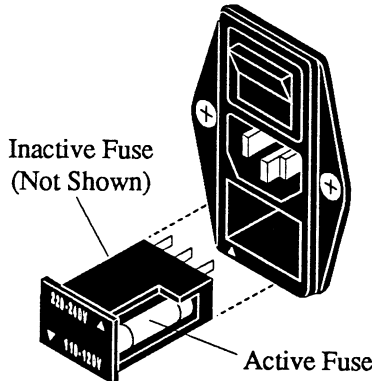
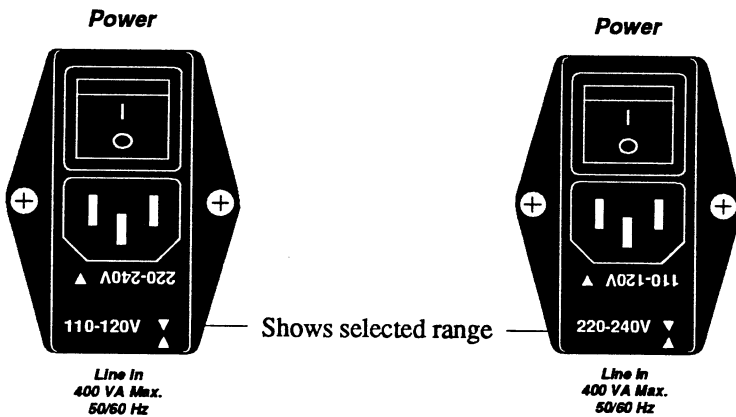

Figure 2 - Replacing the Fuse



Voltage Selector set for 110-120V Voltage Selector set for 220-240V

Figure 3 - Voltage Settings

W	Power Max.	450W		Main Switch	
Hz	Frequency Range	50-60Hz			
	AC Voltage	120V	240V	Power Fuse	
A	Current Max.	5A	2.5A		
	Fuse	7A	4A		

Figure 4 - Pro Series Power Requirements Label

THE PRO SERIES

The power requirement of the Pro Series is nominally 450 volt-amperes. It is designed to operate from a 90V to 132V or 180V to 264V, 1 phase, 50 to 60 Hertz (+5%) source.

⚠ WARNING: Inspect the voltage selectors (Figure 3) at the rear of the Pro Series instrument and Pro Disk option (if one is installed) for the correct settings before applying power.

The power source must include all three of the following.

1. A neutral wire at or near ground potential.
2. A separate safety ground at ground potential.
3. A line (hot) wire.

Figure 1 illustrates the locations of the neutral, line, and earth ground terminals located on the male connector of a U.S. power cord. In other countries, refer to local codes.

Changing the Voltage Selector or Line Fuses

1. Unplug the power cord from the power source.
2. Carefully pry the fuse holder from the instrument using a small common screwdriver (Figure 2).
3. Replace the fuses if necessary and reinsert the fuse holder orientated as required for your power source (Figure 3).

THE PRO DISK OPTION

The power requirement of the Pro Disk option is nominally 100 volt-amperes. It is designed to operate from a 90V to 132V or 180V to 264V, 1 phase, 50 to 60 Hertz (+5%) source.

Note: Also see *Chapter 23* for instructions on how to interface the Pro Series and Pro Disk option.

⚠ WARNING: Inspect the voltage selector (Figure 3) at the rear of **both** units for the correct settings before applying power.

The power source must include all three of the following.

1. A neutral wire at or near ground potential.
2. A separate safety ground at ground potential.
3. A line (hot) wire.

Figure 1 locates the neutral, line, and earth ground terminals located on the male connector of a U.S. power cord. In other countries, refer to local codes.

Changing the Voltage Selector or Line Fuses

1. Unplug the power cord from the power source and the rear panel power receptacle.
2. Carefully pry open the fuse holder at the top of the door and replace the fuses if necessary (Figure 2).
3. Remove the voltage selector and reinsert it such that the proper voltage is visible when the door is closed again (Figure 3).

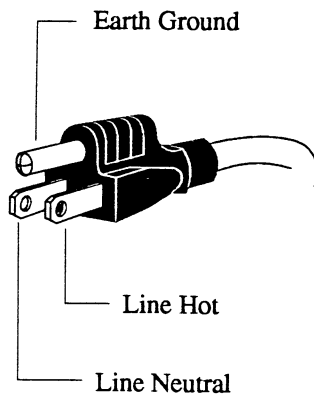

Figure 1 - Male Power Connector

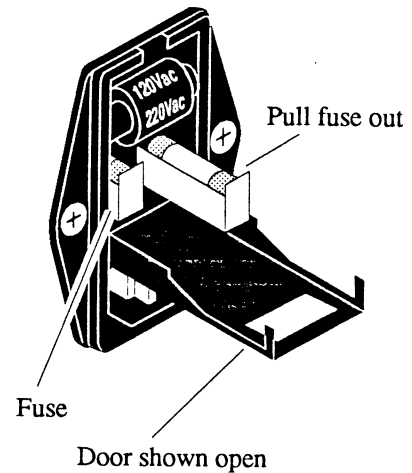

Figure 2 - Replacing the Fuses

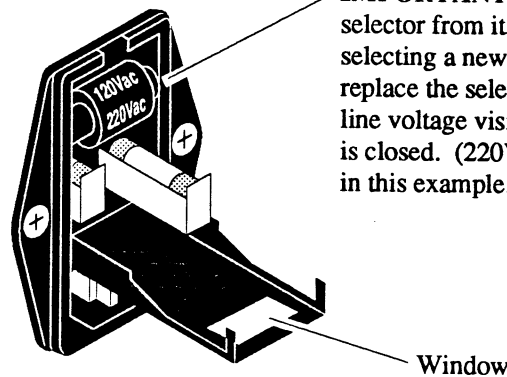

Figure 3 - The Voltage Selector

IMPORTANT: Pull the voltage selector from its holder before selecting a new voltage. Then replace the selector with the proper line voltage visible when the door is closed. (220V has been selected in this example.)

W	Power Max.	90W		Main Switch	
Hz	Frequency Range	50-60Hz			
	AC Voltage	120V	240V	Power Fuse	
A	Current Max.	600mA	300mA		
	Fuse	2A	1A		

Figure 4 - The Pro Disk Power Requirements Label

THE BACKUP BATTERY

Your Pro instrument uses a 3 volt (Panasonic® BR-C) lithium battery to backup the front panel settings and any downloaded programs stored in memory.

If you should temporarily lose power to the instrument, the instrument is designed to default to its last front panel settings and retain any downloaded programs stored in memory when power is applied again.

Identifying a Battery Failure

If the Pro scope detects a battery failure upon the initial application of power to the Pro instrument, the front panel settings revert to their defaults (e.g., volts = 120 V, inputs grounded, etc.), the date on the System Configuration menu (*Chapter 21*) changes to 01/01/89 and the clock resets to 00-00-00 and then starts timing again.

CAUTION: You should replace the spent battery immediately.

Use the Set Date/Time function (*Chapter 21*) to set the current date and time.

Replacing the Backup Battery

Note: To retain stored information, leave power on to the Pro instrument while changing the battery.

1. Unscrew the battery holder's cover at the rear of the instrument.
2. Replace the old battery with a fully charged battery.
3. Replace the battery holder's cover.

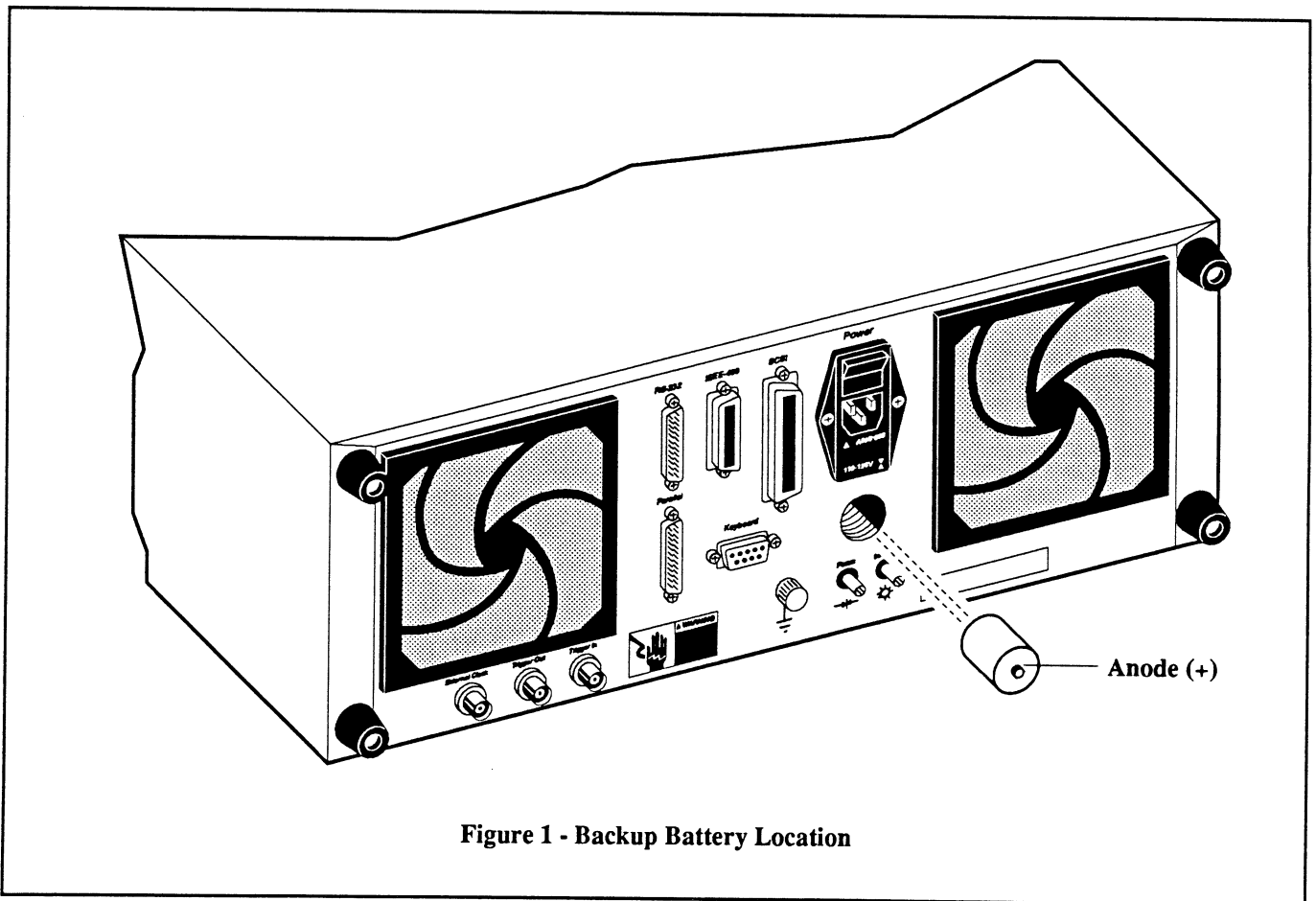

Figure 1 - Backup Battery Location

POWER INTERFACE

Connecting the power cable as shown in Figure 1 allows the front panel Power On/Off switch on the Pro Disk to control power to both units. Leave the Pro Series rear panel power switch in the ON position when using this configuration.

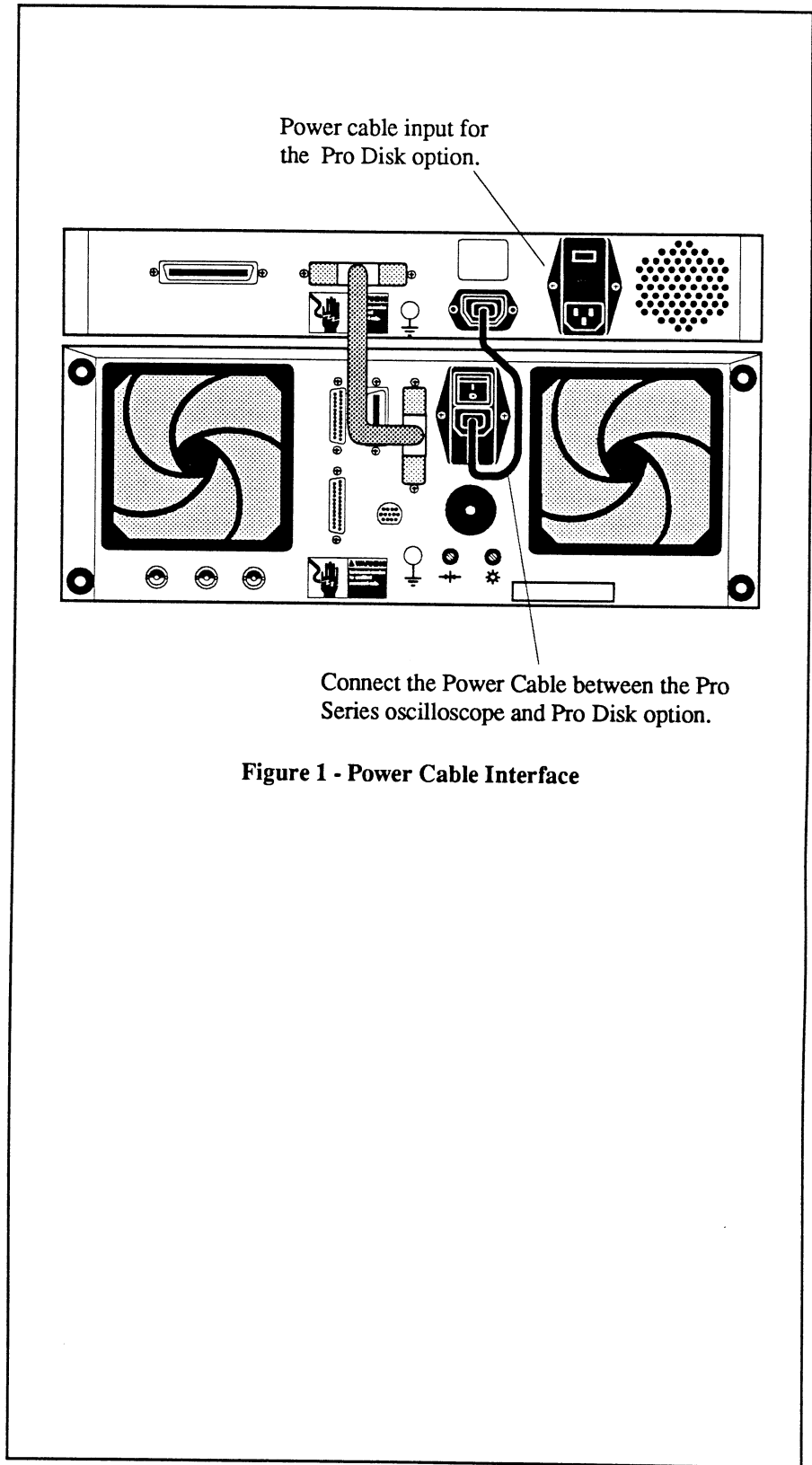

Figure 1 - Power Cable Interface

Chapter 6

TUTORIAL

This tutorial should be performed by users unfamiliar with digital oscilloscopes. It is intended only to familiarize new users with the basic front panel controls. Detailed information and additional features are described later in this manual beginning with *Chapter 7*.

The Tutorial uses a two channel configuration as an example.

IMPORTANT: The entire Tutorial must be performed sequentially. Do NOT skip any steps or procedures.

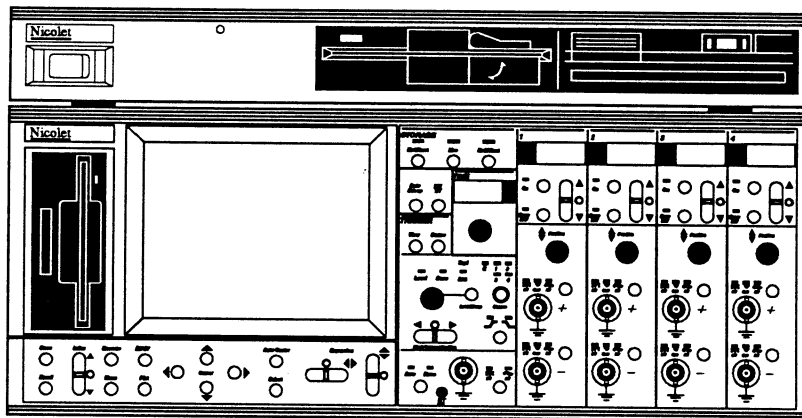

Four channel Pro Series Digital Oscilloscope with the Nicolet Pro Disk Multiple Storage Option

⚠ WARNING: Inspect the voltage selector at the rear of the instrument (and optional Pro Disk if one is installed) for the correct setting(s) before applying power. See Chapter 5.

INITIAL SETUP

⚠ WARNING: Inspect the voltage selector at the rear of the instrument for the correct setting before applying power. See Chapter 5.

1. Ensure that the POWER switch, located at the rear of the instrument, is in the "OFF" position.
2. Ensure that the disk drive is not loaded with a diskette.
3. Plug in the power cord to the rear of the instrument and then to the appropriate power source.
4. Apply power to the instrument by placing the Power switch on the rear panel to the ON position.
5. Turn on only channel 1; On LED (A) should be illuminated. Turn off the other channel(s).
6. Press the Channel 1 Volts button (B) until a 6 appears on the Volts readout (C).
7. Adjust the Time control (D) until 5.0μ appears on the Seconds readout (E).
8. Press the trigger Source button (F) until the 1 LED illuminates.
9. Press the trigger Mode button (G) until the Norm LED illuminates.
10. Press the channel 1 +input BNC Coupling button (H) until the AC LED lights (I).

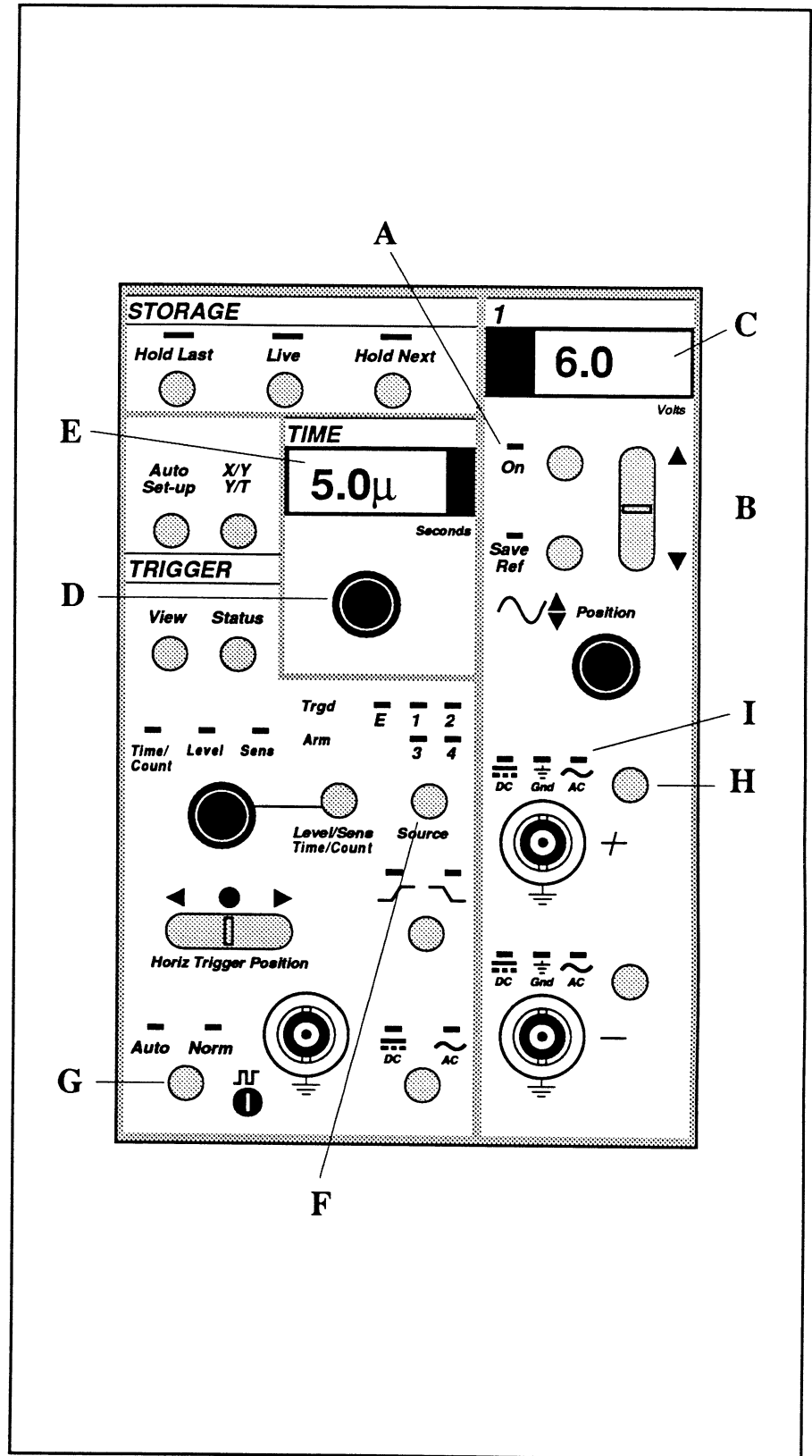

OBTAINING A WAVEFORM DISPLAY

An external signal source is not required. However, if a signal generator is available, use it to simplify the following procedures. This signal can be input in place of the test probe set-up shown Figure 1.

1. Press the Live button (A).
2. **If using the X1 Test Probe:** Connect the X1 test probe to the instrument as shown in Figure 1 or use the Signal Generator Setup described below.

Note: Unless noted, the test probe must remain attached to the compensation point if a signal generator is not being used to generate signals.

If using a Signal Source:

Input a 1 KHz sine wave signal to the channel 1 (+) input BNC with a BNC cable and adjust the amplitude of the signal for approximately a 3/4 full screen display.

Note: If a signal does not appear, press the Auto Set-up button (B). The instrument will automatically select the optimum settings to capture the signal.

4. Center the waveform by adjusting the Channel 1 Position control (C).
5. Press the Hold Next button (D) to capture one last sweep.

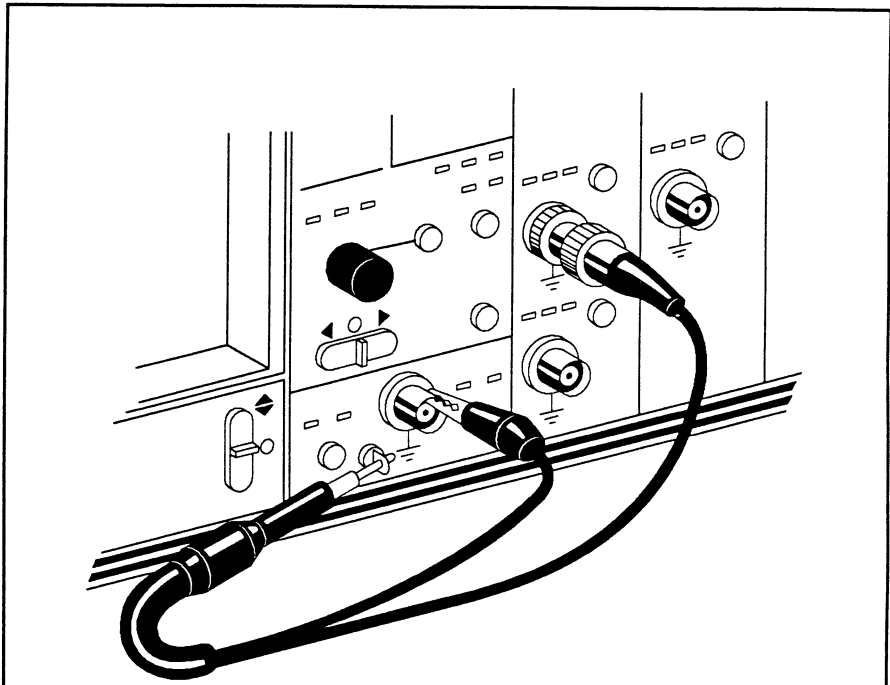
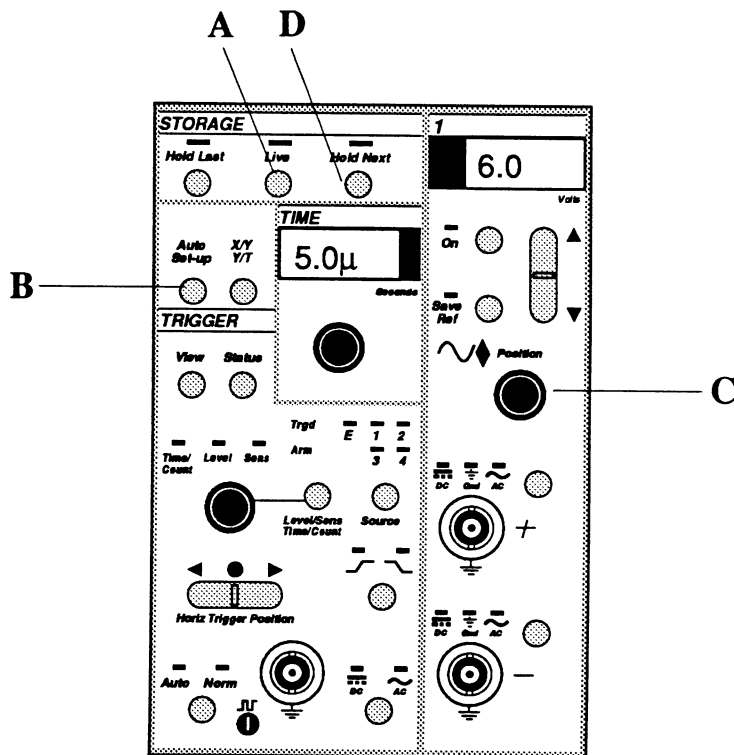

Figure 1 - Using the Compensation Point as the signal source for channel 1.



THE CURSOR BUTTONS

1. Momentarily press the Right Cursor button (A) several times while observing the Time numerics (Figure 1). The numerics increment by $5 \mu\text{S}$ each time the Right Cursor button is pressed, the $5.0 \mu\text{S}$ Time setting.
2. Press and hold the Right Cursor button (A). The vertical cursor moves across the screen at a slow rate.
3. Release the Right Cursor button (A) and then immediately press and hold it again. The cursor moves across the screen at a faster rate of movement.
4. Release the Right Cursor button and then immediately press and hold it again. The cursor's rate of movement increases again. The cursor's speed continues to increase each time step #4 is repeated until the maximum rate has been reached. The cursor will stop when it reaches the extreme right side of the screen.
5. While observing the vertical cursor, release the Right Cursor button and then press and hold it in again. The vertical cursor "wraps-around" to screen left and continues to move across the screen at a slow rate of movement. The cursor "wrap-around" feature allows you to quickly reposition a cursor to the opposite side of the screen without "back-tracking" across the screen.
6. Release the Right Cursor button.

Note: This feature also works with the Up and Down Cursor buttons for the Horizontal Cursor.

7. Simultaneously press the Up and Down Cursor buttons. The horizontal cursor jumps to the zero volts level.
8. Simultaneously press the Left (B) and Right (A) Cursor buttons. The vertical cursor jumps to the trigger ($t=0$) point.

Note: Steps 9 through 11 are not functional with a square wave signal. Perform these steps only if you are inputting a sine wave signal.

9. Press and hold the Up Cursor button (C) and momentarily press the Right Cursor button. The crosshair now jumps to each of the waveform peaks as the Right Cursor button is pressed.
10. While observing the display screen, press and hold the Right Cursor button (A) and then momentarily press the Down Cursor button (D) a few times. The crosshair "jumps" to the next waveform valley to the right of the crosshair each time the Down Cursor button is pressed.
11. Release the Cursor buttons.

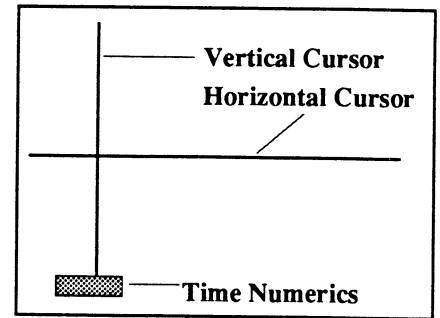
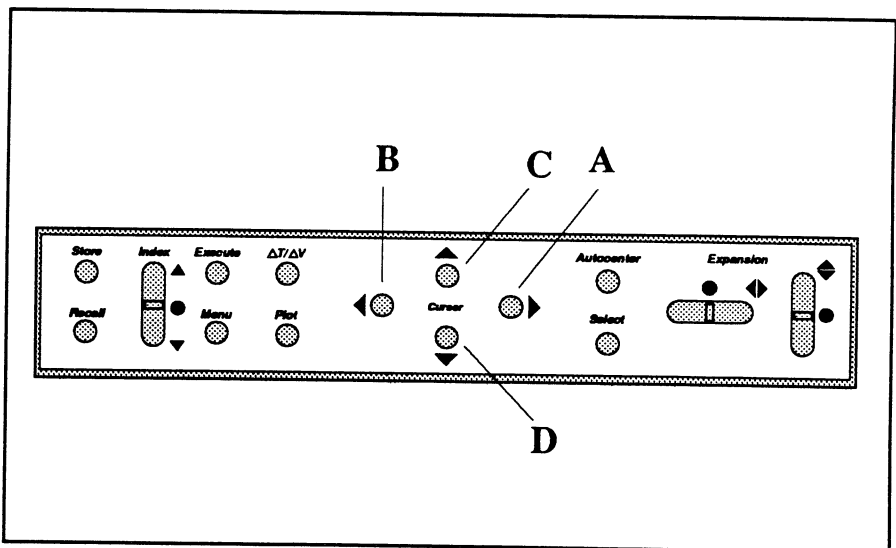

Figure 1 - Cursors and Time Numerics



THE TIME CONTROL

1. Press the right side of the Horizontal Expansion button (A) until maximum expansion is achieved. Note that the waveform is comprised of many small dots called "data points."
2. Press the Right Cursor button (B) several times while observing the left (Time) numerics. The Time Numerics increment by 5.0 μ S, the Time control setting. The Time Numerics decode the acquisition times measured with respect to the trigger time (T=0).
3. Adjust the Time control (C) until 10 μ S appears (D).
4. Press the Hold Next button (E).

5. Press the Right Cursor button (B) while observing the Time numerics (Figure 1). The Time Numerics now increment by 10.0 μ S, the new Seconds readout setting.
6. Press the center of the Horizontal Expansion switch (A). The display returns to an unexpanded display.
7. Return the Seconds readout (D) to 5.0 μ S.
8. Press the Live button and count the number of displayed cycles.
9. Set the Time control to 10.0 μ S and count the number of cycles displayed on the screen. The trace now contains twice as many cycles because the sweep time has been doubled.
10. Return the Seconds readout to 5.0 μ S.
11. Press the Hold Next button.

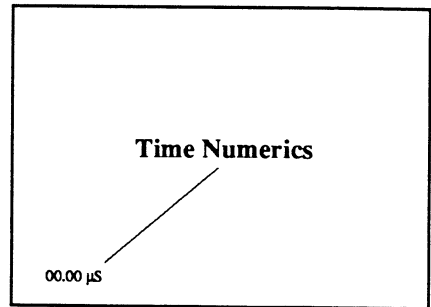
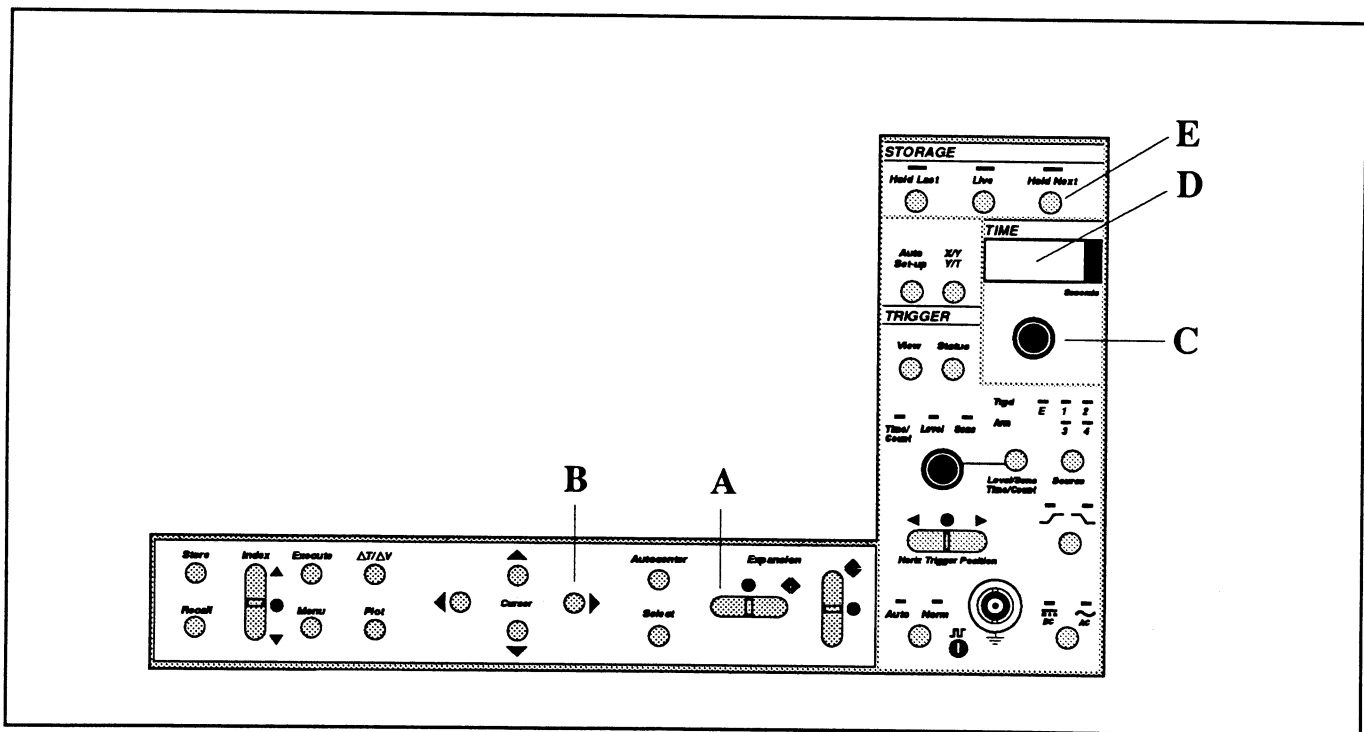

Figure 1 - Time Numerics



THE VOLTS CONTROL

The Volts setting determines the maximum full scale voltage that can be input to the instrument (when Vertical Expansion is turned off) without exceeding the screen's vertical display limits.

1. While observing the Voltage numerics (Figure 1), press and hold the Up Cursor button (A). The Voltage numerics decode the voltage levels (refer to *Chapter 12, Volts Control*) as the cursor moves vertically on the screen.
2. Release the Up Cursor button.
3. Turn Autocenter on by pressing the Autocenter button (B). The horizontal cursor vertically repositions to the data point through which the vertical cursor is passing.

4. Press and hold the Right Cursor (C) button while observing the screen. The numerics simultaneously decode the time and voltage coordinates of each data point as the crosshair traces the waveform.
5. Press the Live button (D).
6. Change the channel 1 Volts control (E) to 12V (F) while observing the display screen. Increasing the Volts setting decreases the displayed waveform's amplitude. Larger Volts settings allow larger signals to be displayed without exceeding the screen's limits when vertical expansion is turned off.
7. Return the channel 1 Volts setting to 6V.
8. Press the Hold Next button (G).

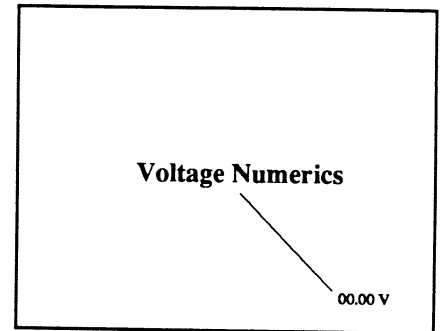
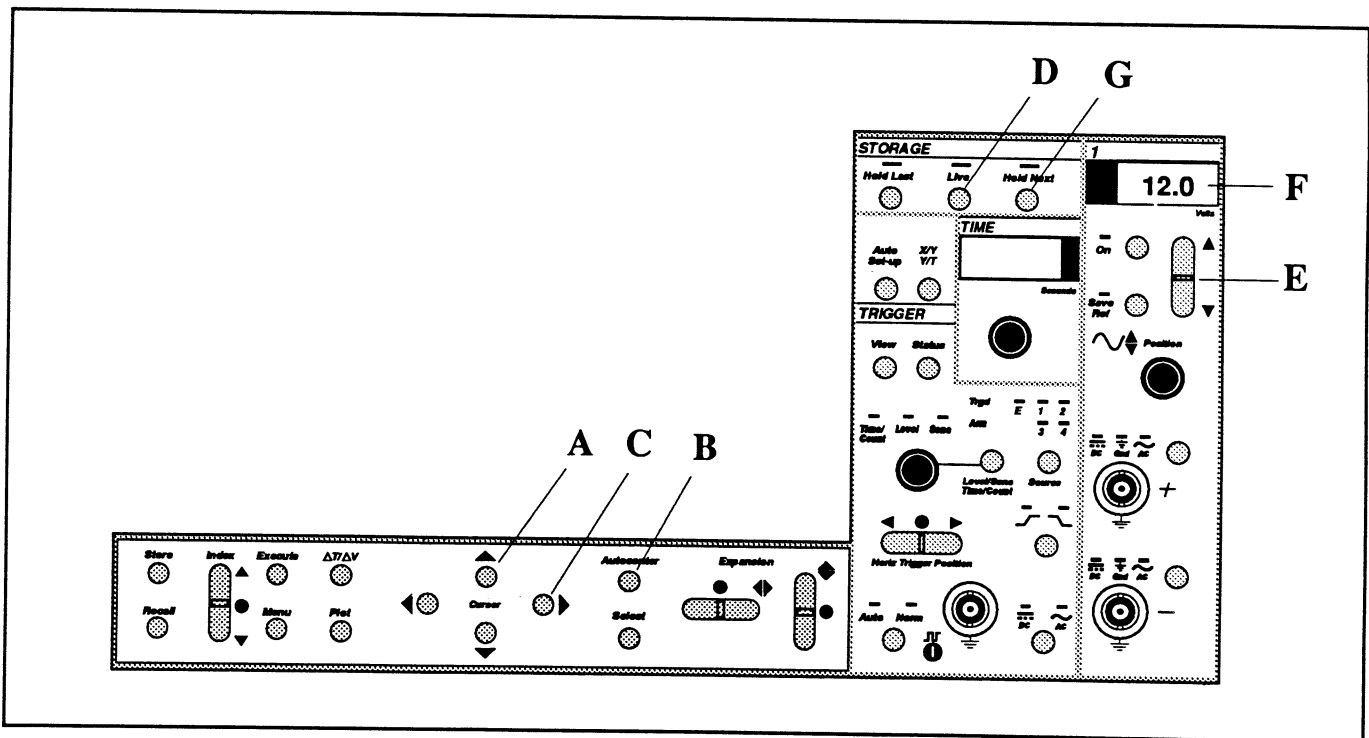

Figure 1 - Voltage Numerics



EXPANSION BUTTONS

The Expansion buttons enable very small areas of interest to be expanded for closer inspections.

1. Position the vertical cursor anywhere in the first half of the display screen using the Left or Right Cursor button (A or B).
2. Press the right side of the Horizontal Expansion button (C) several times while observing the waveform. The vertical cursor and the area immediately surrounding the crosshair reposition to screen horizontal center. The waveform continues to expand horizontally each time the button is pressed.

3. Press the top of the Vertical Expansion button (D) several times. The horizontal cursor and the data points immediately surrounding the cursor reposition to screen vertical center. The waveform continues to expand vertically each time the button is pressed.

4. Press and hold the Right Cursor button (B) while observing the screen. The waveform passes through the crosshair at screen center. The numerics decode the time and voltage of each data point as they pass through the crosshair.

5. Release the Right Cursor button.

6. While observing the screen, press the Up Cursor button (E), release it and then press and release the Right Cursor button (B).

Note: Pressing the Up or Down Cursor buttons automatically turn off the Autocenter mode.

The "screen" responds in the direction of the Cursor button being pressed.

Note: Think of the trace as being stationary and the screen as being movable when inspecting expanded waveform displays.

7. Press the center of the Vertical Expansion button (D) and then the center of the Horizontal Expansion button (C) to turn expansion off.

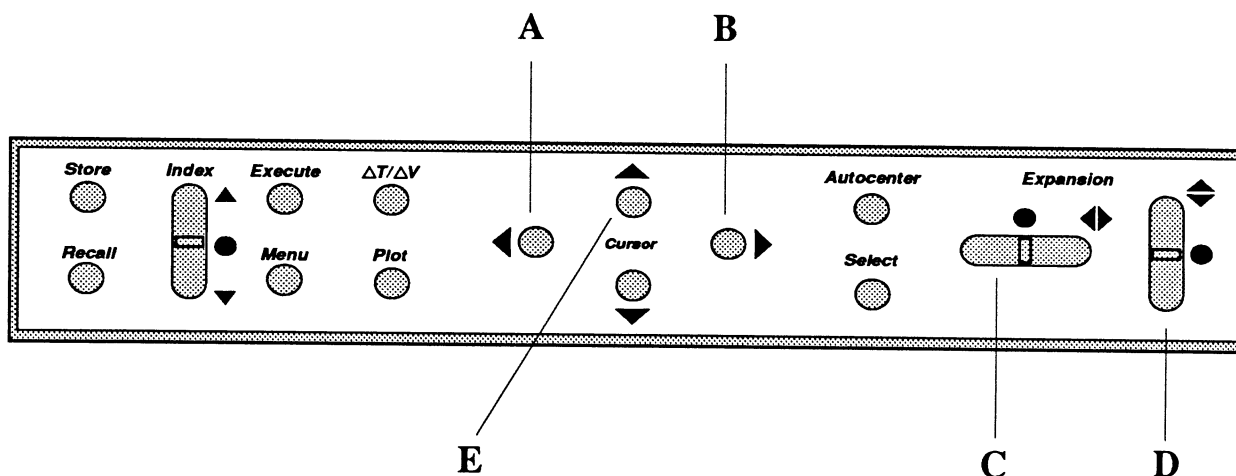

POSITION CONTROL

The Position control is used to vertically reposition a waveform on the screen.

1. Rotate the Channel 1 Position control (A) while observing the waveform display. The waveform moves vertically on the screen.
2. Return the waveform to the center of the screen.

CHANNEL ON BUTTON

Turning a channel on allows it to display data stored in memory and capture new data when a sweep is triggered while in the Live mode.

Turning the channel off guards the data stored in its memory. This data remains intact, regardless of whether a new sweep is triggered.

1. Turn channel 1 off by pressing the Channel 1 On button (B). The channel 1 On LED and Live LED turn off and the Hold Last LED turns on. An "About" screen appears because now all of the channels are turned off.
2. Press the Live button (C). Pressing the Live button has no effect because all of the channels are turned off.
3. Press the Channel 1 On button (B) to turn channel 1 on again. The channel 1 waveform reappears on the screen.

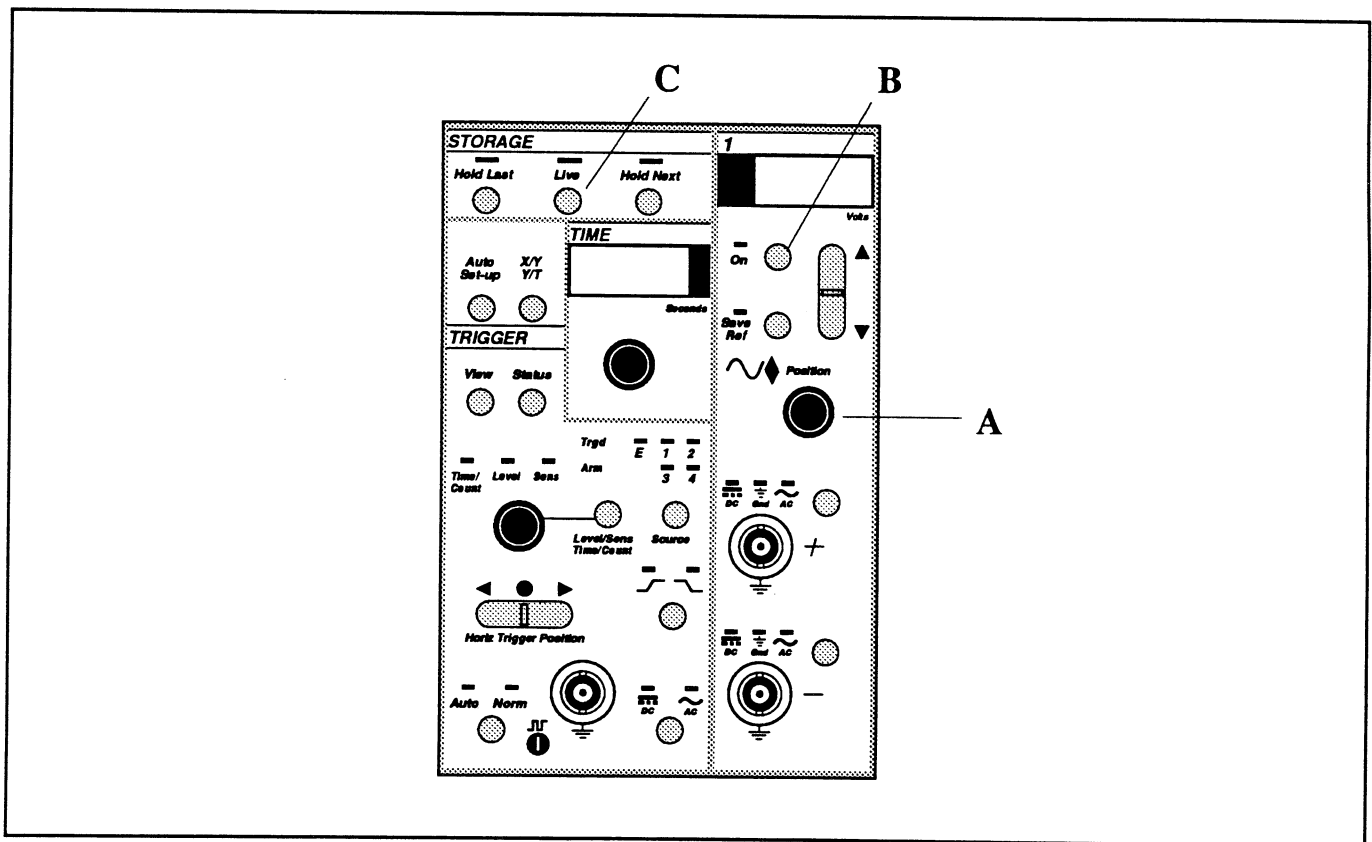

SAVE REF BUTTON

The Save Ref button allows you to compare a "live" waveform with a "saved" waveform captured by the same channel under identical conditions.

1. Press the Channel 1 Save button (A) to turn on the Save Ref mode.
2. Change the Seconds readout (B) to 10.0 μ S. A second "live" waveform with twice the frequency of the original "saved" waveform appears on the screen.

SELECT BUTTON

The Select button allows you to select which waveform will be decoded by the numerics when multiple waveforms are displayed on the screen.

1. Note that the Channel Identifier (Figure 1) towards the bottom center of the screen reads "1" and that the "live" signal appears brighter on the screen. The numerics are now decoding the "live" waveform.
2. Press the Select button (C). Now the Channel Identifier reads "1S" and the "saved" waveform is displayed brighter. The numerics are now decoding the "saved" waveform. The "1S" means that the selected waveform was captured by channel "1" and then "S"aved in one-half of channel 1's reference memory.
3. Press the Hold Next button (D).

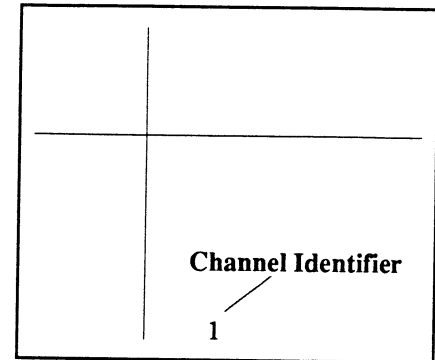
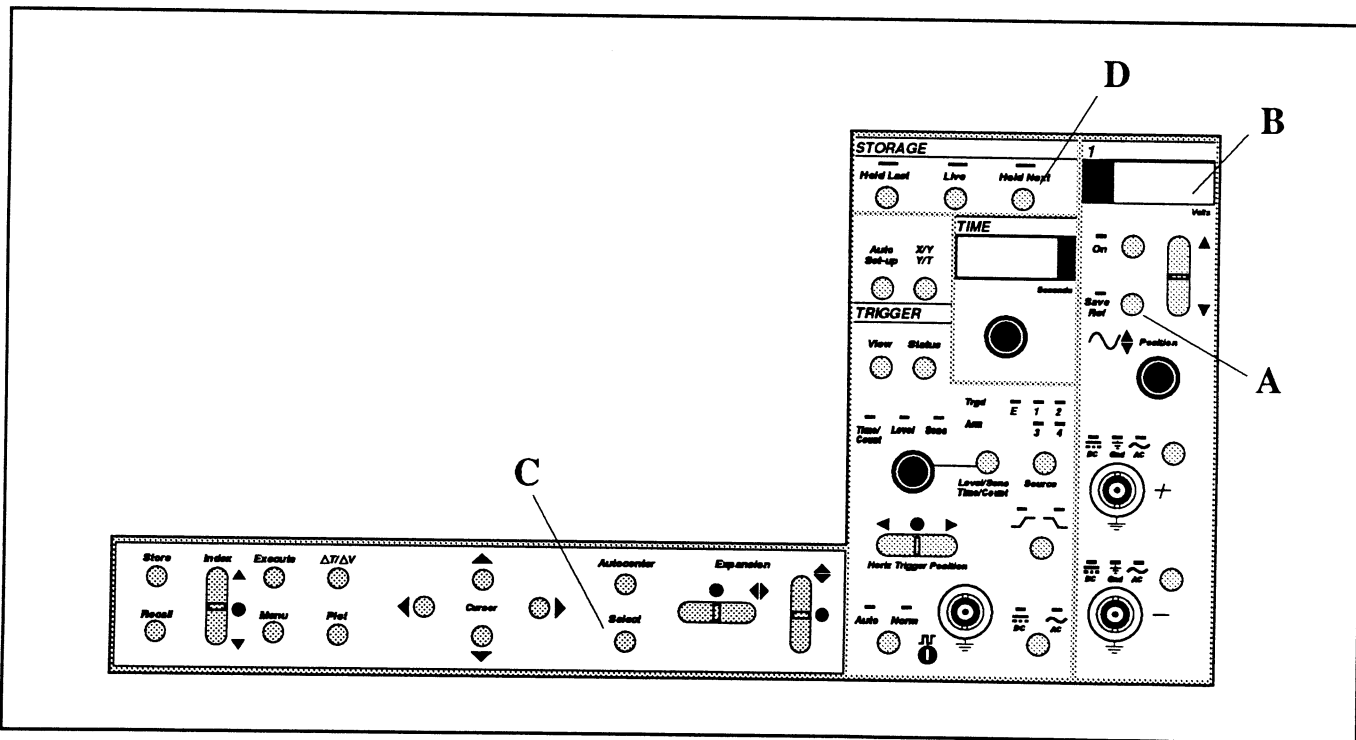

Figure 1 - Channel Identifier



AUTOCENTER BUTTON

The Autocenter mode (along with the display expansion modes) determines the cursor functions.

Autocenter Off

Turning Autocenter off allows the cursors to be independently positioned on the screen when display expansion is also turned off.

1. Press the Left Cursor button (A). The vertical cursor moves across the screen while the left numerics decode the time coordinates.
2. Release the Left Cursor button and press the Up Cursor button (B). The horizontal cursor moves vertically on the screen while the right numerics decode voltage values.

Autocenter On

Turning Autocenter on allows the numerics to simultaneously decode Time and Voltage values using only the Left or Right Cursor button.

3. Turn Autocenter on by pressing the Autocenter button (C). The horizontal cursor (Figure 1) "jumps" vertically to the data point being decoded by the vertical cursor and the Autocenter Marker appears on the screen.

4. Press the Left Cursor button (A). The crosshair (Figure 1) traces the selected waveform and the numerics simultaneously decode the time and voltage values of each data point as the waveform is traced.
5. Apply a small amount of Horizontal Expansion (D) and Vertical Expansion (E). The crosshair and waveform immediately surrounding the crosshair move to screen center.
6. Press the Right Cursor button (F). The selected waveform passes through the crosshair at screen center.
7. Press the center of the Horizontal and Vertical Expansion buttons (D and E) to turn expansion off.

Note: Remember that Autocenter turns off automatically if you press the Up or Down Cursor buttons.

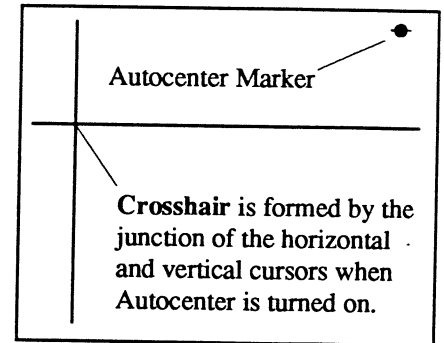
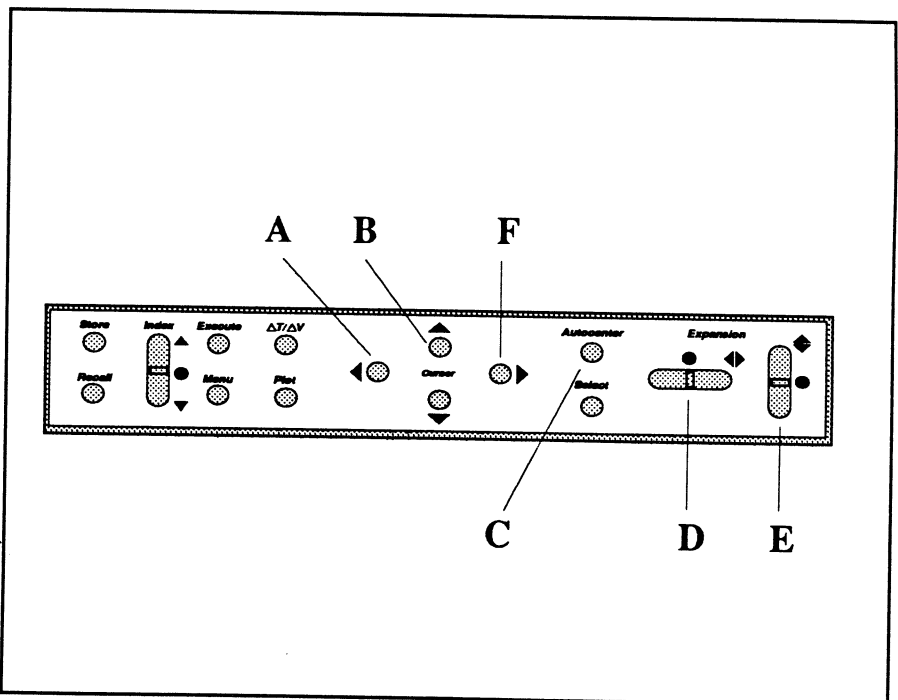

Figure 1 - The Crosshair and Autocenter Marker



XY / YT BUTTON

The XY/YT button allows you to decide how data will be displayed on the screen for inspections.

YT Display Mode

The YT mode displays waveforms as voltage functions of time. You have been using the YT display mode up to this point in the Tutorial.

XY Display Mode

The voltage values of one waveform are plotted against the voltage values of another when the XY display mode is selected.

1. Press the XY/YT button (A). An XY display selection screen appears.
2. To display waveform 1 vs 1S, press the channel 1 On button (B), then the channel 1 Save Ref button (C) and then press the XY/YT button (A). The XY waveform display appears.
3. Press the Right Cursor button (D). The crosshair traces the waveform because Autocenter is still on. The left numerics decode x-axis voltages and the right numerics decode the y-axis voltages.

4. Apply a small amount of Horizontal Expansion (E) and Vertical Expansion (F).
5. Press the Left Cursor button (G). The waveform passes through the crosshair locked at screen center.
6. Press the center of the Horizontal Expansion button (E) and Vertical Expansion button (F) to turn expansion off.
7. Press the XY/YT button (A). The two original waveforms are displayed again in the YT mode.
8. Press the Channel 1 Save Ref button (C). The Save Ref LED turns off and the "saved" waveform disappears from the screen.

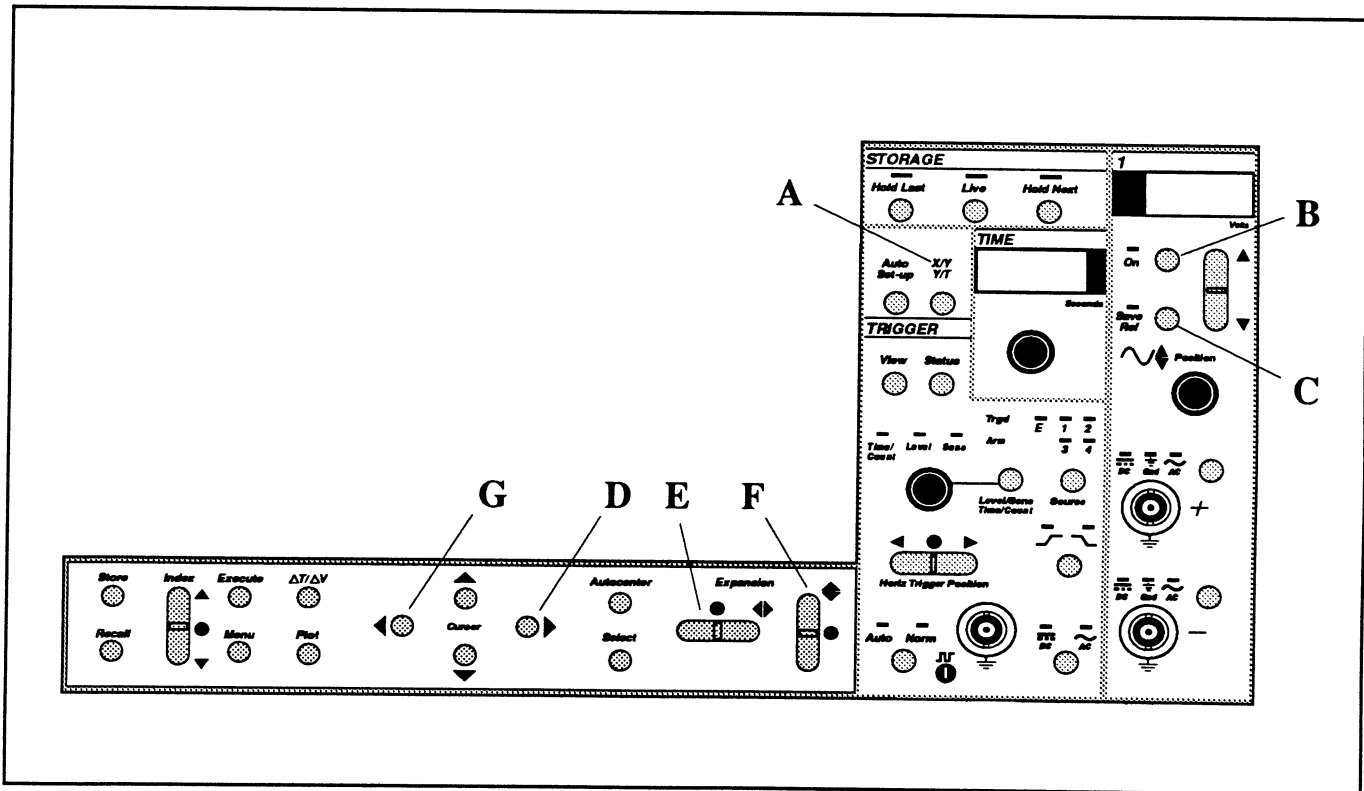

THE $\Delta T/\Delta V$ BUTTON

The $\Delta T/\Delta V$ mode allows you to make comparative time and voltage measurements between any two features of the selected waveform and read the values directly from the $\Delta T/\Delta V$ numerics.

1. Using the Left or Right Cursor button, position the crosshair over the first positive peak of the displayed waveform.
2. Press the $\Delta T/\Delta V$ button (A).

A second set of numerics and a $\Delta T/\Delta V$ marker (small crosshair) appear on the screen (Figure 1). The $\Delta T/\Delta V$ marker identifies the $\Delta T=0$ and $\Delta V=0$ coordinates.

3. Press the Right Cursor button.

The lower numerics continue to decode time and voltage values with reference to the original $T=0, V=0$ coordinates. The ΔT and ΔV numerics decode time and voltage values with respect to the $\Delta T=0, \Delta V=0$ coordinates.

4. Continue pressing the Right Cursor button until the crosshair is positioned over the first valley of the waveform.

The ΔV numerics now show the peak-to-peak voltage and the ΔT numerics show the time difference between the two peaks.

5. Press the $\Delta T/\Delta V$ button (A) to turn the $\Delta T/\Delta V$ mode off.

The $\Delta T/\Delta V$ Marker and $\Delta T, \Delta V$ numerics disappear from the screen.

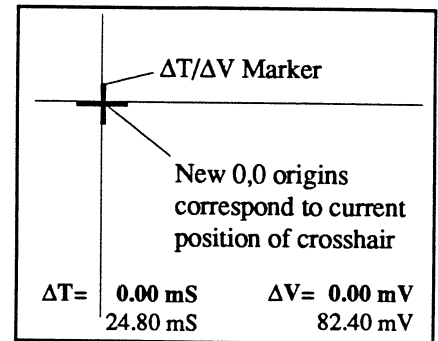
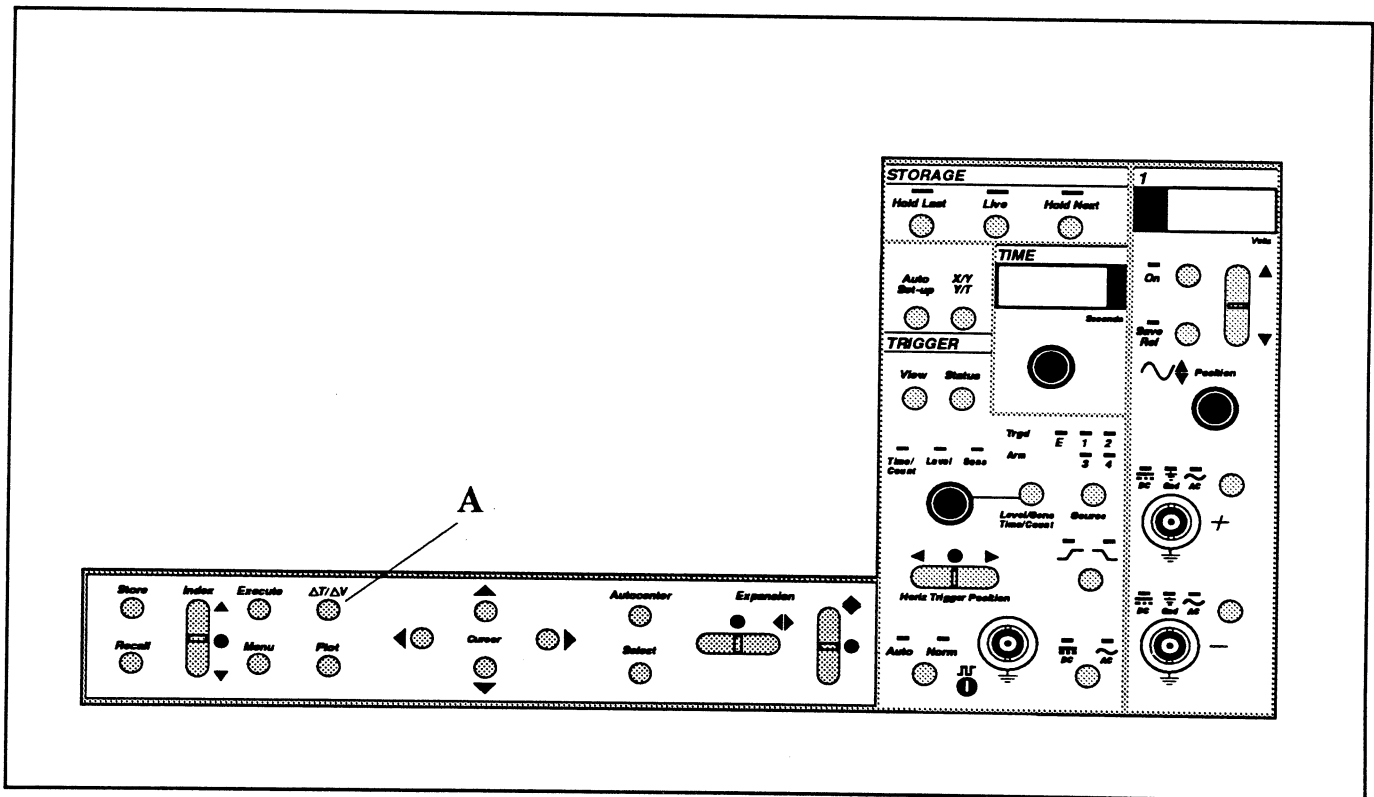

Figure 1 - Reset Numerics On



STORAGE BUTTONS

The Storage buttons (Live, Hold Next, Hold Last) provide three modes of signal acquisition.

The Live Button

New data is captured and displayed each time a valid trigger initiates a sweep and the channel(s) is turned on.

1. Set the Seconds readout (A) to 5.0 μ S.
2. Press the Live button (B).

The waveform that was previously stored in channel 1 is now replaced with a new waveform. Note that the Arm (D) and Trgd (E) LEDs continue to flash on and off, indicating that sweeps are continually being triggered.

The Hold Last Button

Press the Hold Last button to store data captured during the last full sweep. If a sweep is in progress when the button is pressed, then the data captured during this sweep will be stored when the sweep is completed.

3. Set the Seconds readout to 2.0 mS.
4. While a sweep is in progress, press the Hold Last button (C). Both the Hold Last and the Live LEDs are now illuminated.

The Live LED turns off at the end of the sweep and the captured data is stored in memory. Note that the Arm (D) and Trgd (E) LEDs no longer light, indicating the scope is not armed and no new sweeps are being triggered.

The Hold Next Button

Press the Hold Next button to store data captured following the next valid trigger. If a sweep is already in progress when the button is pressed, the sweep is allowed to finish and the next valid trigger will initiate a final sweep.

5. Set the Seconds readout to 1.0 mS.
6. Press the Hold Next button (F).

The Live and Hold Next LEDs light. When a sweep is triggered, the Hold Next LED turns off and the Hold Last LED turns on while the Live LED remains on.

The Live LED turns off at the end of the sweep and the scope enters into the Hold Last mode (Hold Last LED on only). The Arm (D) and Trgd (E) LEDs remain off.

7. Set the Seconds readout (A) to 2.0 mS.
8. Press the Live button (B). The Arm (D) LED lights.
9. Wait for the Trgd LED (E) to light and then press the Hold Next button (F).

The Live and Hold Next LEDs light. When the current sweep is completed and the next sweep is triggered, the Hold Next LED turns off and the Hold Last LED turns on (the Live LED remains on).

When this final sweep is completed, the Live LED turns off and the scope enters into the Hold Last mode. The Arm (D) and Trgd (E) LEDs remain off.

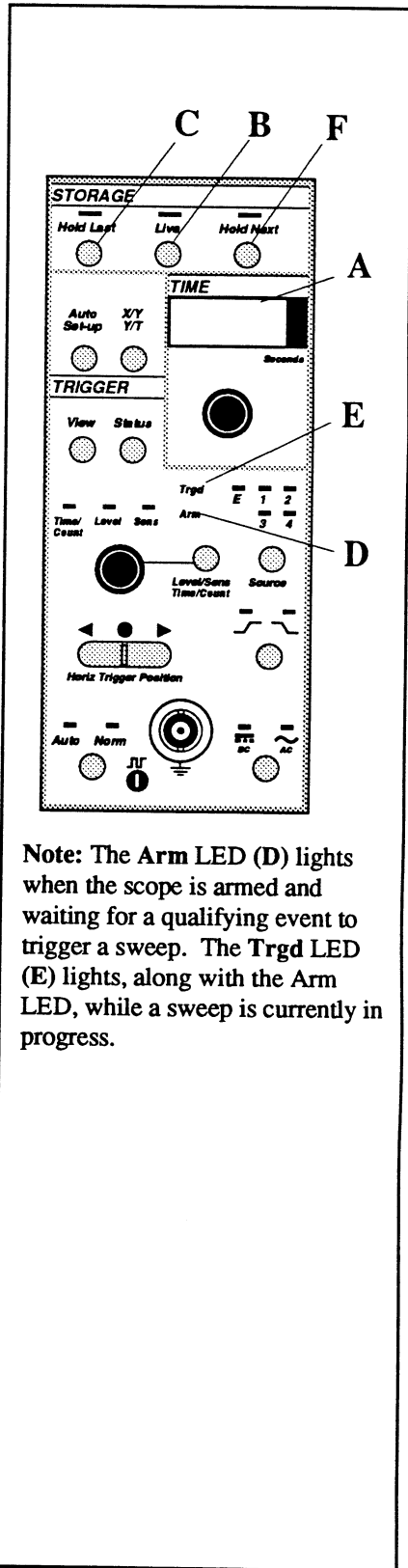

Note: The Arm LED (D) lights when the scope is armed and waiting for a qualifying event to trigger a sweep. The Trgd LED (E) lights, along with the Arm LED, while a sweep is currently in progress.

SWEEP REVIEW

The Index button (A) is a multifunction control. For now, only the Sweep Review feature will be discussed.

This feature allows you to review a historical record of data captured during previous sweeps. You can treat these waveforms the same as you have done throughout this chapter, e.g., decode time and voltage values, expand the waveform display, etc.

The number of sweeps that can be reviewed is a function of the Sweep Length Function (see Chapter 10 and Chapter 17). Once the Sweep Review memory is full, it discards the oldest sweep to make room for the newest sweep.

1. Press the top of the Index button (A). Note that two fields of information appear at the top of the screen (Figure 1). You are now viewing data captured during the previous sweep.
2. Press the top of the Index button several more times. Each time the button is pressed, the sweep review memory goes back in time, thus displaying older and older data.

Note: Some sweeps will have identical waveforms if no changes were made between sweeps.

3. Press the center of the Index button. The system redisplay the data captured during the most current sweep (Figure 2).
4. Press the bottom of the Index button several times. The sweep review memory goes to the oldest stored sweep and then moves forward toward the present time each time the button is pressed.
5. Press the center of the Index button. The instrument returns to the current acquisition display.

Note: Pressing and holding down the top or bottom of the Index button allows you to scan through the sweep review memory. The instrument will sound a "beep" and pause momentarily when the current archive has been reached.

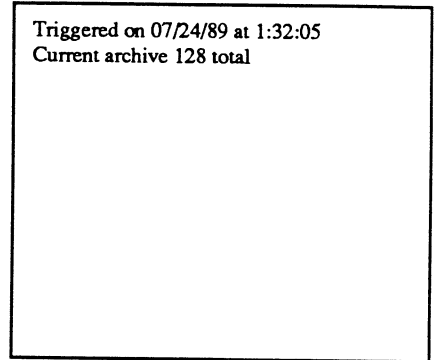

Figure 1

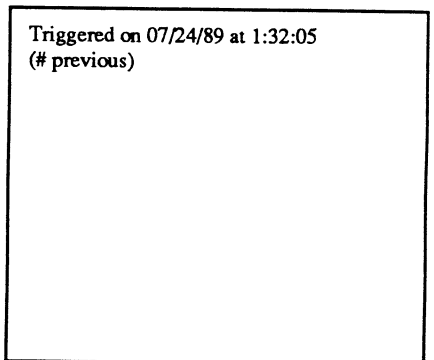
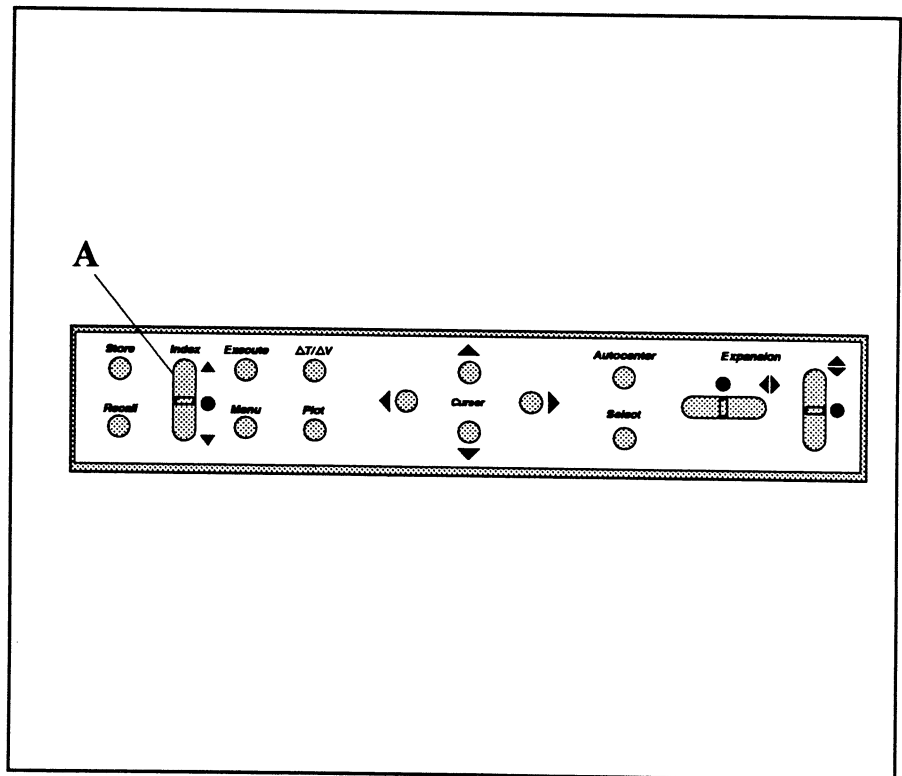

Figure 2



AUTO/NORM BUTTON

Sweeps can be triggered automatically without any valid triggers or triggered solely by valid triggers input to the instrument.

Auto Triggering

Sweeps are triggered internally after a short wait if a valid trigger is not received. If a valid trigger is input during this period, the instrument will "lock" onto the trigger signal.

1. Press the trigger Auto/Norm button (A) to select Auto triggering. The Auto LED lights.
2. Set the Time control (B) to 10 μ S.
3. Press the Live button (C).
4. Press the trigger Level/Sens button (D) until the Level LED lights and then adjust the trigger Level control (E) clockwise while observing the screen. When sweeps are triggered internally by the instrument, the waveform will become unstable if triggers are not in sync with the input signal.
5. Adjust the trigger Level control (E) counterclockwise until a steady waveform display appears. When the input signal qualifies as a valid trigger, the trigger detection circuit locks onto the signal and the resulting waveform display once again becomes stable.

Normal Triggering

Sweeps are generated solely by valid triggers.

6. Press the trigger Auto/Norm button (A). The Norm LED lights and sweeps are now triggered solely by valid triggers input to the channel 1 (+) input BNC.

7. Adjust the Level/Sens control (E) clockwise until the Trgd LED (F) remains off. The instrument no longer sweeps because the input signal does not qualify as a valid trigger.
8. Adjust the Level/Sens control (E) until sweeps are once again triggered.

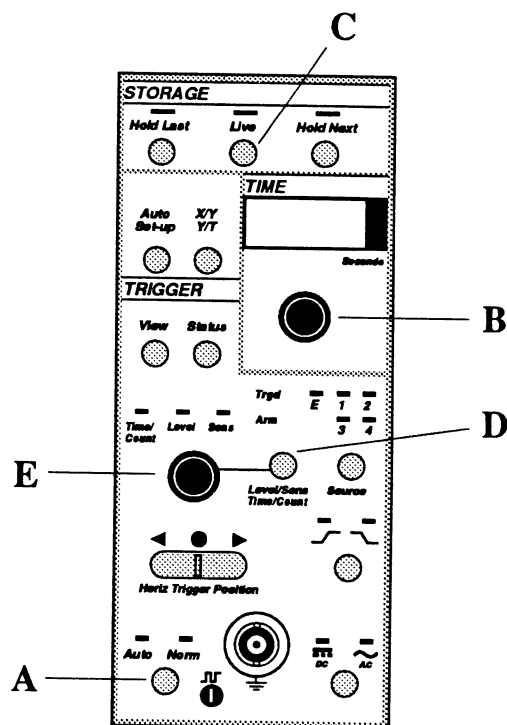

SLOPE BUTTON

The trigger Slope button (A) determines whether increasing and/or decreasing voltages qualify as valid triggers. The direction of the trigger slope marker's arrow head at the left edge of the screen shows you which slope has been selected (Figure 1).

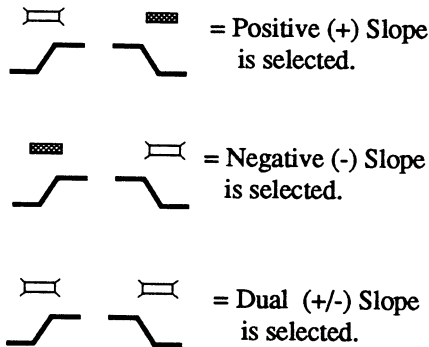

Positive (+) Slope Triggering

Only increasing voltages qualify as valid trigger sources when positive (+) slope triggering is selected. Note that the voltage begins to increase at the left edge of the screen because positive slope triggering is currently being used to qualify triggers.

Negative (-) Slope Triggering

Only decreasing voltages qualify as valid trigger sources when negative (-) slope triggering is selected.

1. While observing the left edge of the screen, press the trigger Slope button (A) once. The LED above the negative slope symbol lights and the signal's voltage is decreasing as it begins at the left edge of the screen.

Dual (+/-) Slope Triggering

Either increasing or decreasing voltages qualify as valid trigger sources.

2. Press the Slope button (A). Both LEDs above the button are now illuminated, indicating that dual slope triggering is selected. The display is unstable because the triggers are repeating rapidly with each slope of the waveform.
3. While observing the left edge of the waveform, press the Hold Next button (B) several times after each sweep is completed. The waveform may start with either a positive or negative slope.
4. Press the trigger Slope button (A). The LED above the positive slope symbol lights.

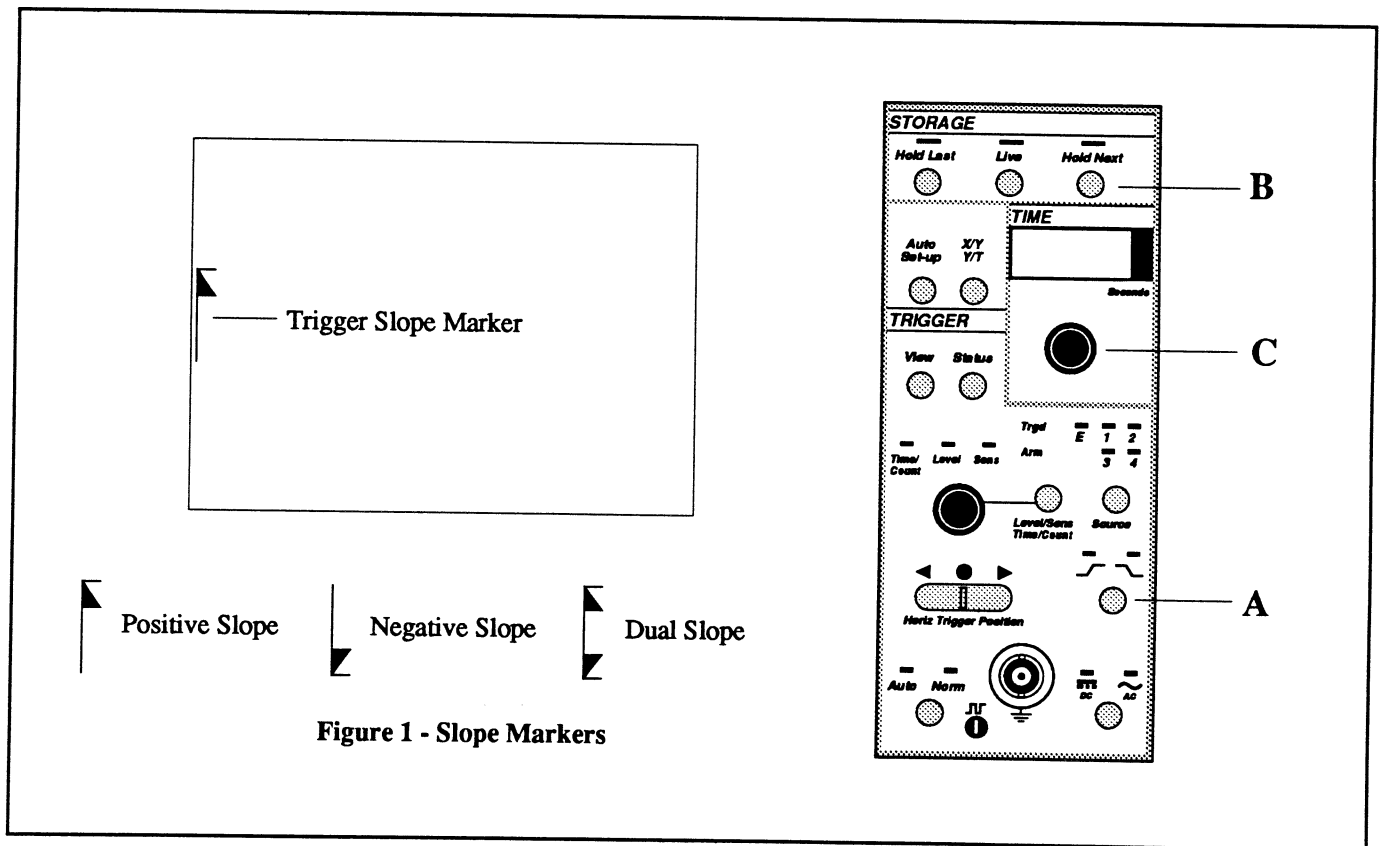

SOURCE BUTTON

The trigger Source button is used to select the origin of the triggering signal.

Channel 1, 2, 3, or 4 Selected

Triggers are derived from signals input to the channel 1, 2, 3, or 4 amplifier according to whichever LED is illuminated on the front panel and the number of channels installed.

A valid trigger input to the selected channel will trigger sweeps on any other channel(s) also turned on, even if the "triggering" channel is turned off.

Note: The 'OR' Triggering function (Chapter 18) must have both Channel 1 and Channel 2 check marked to observe the results in Step 4 on this page.

Note: If you are using the compensation point as your signal source, skip the procedures on this page. If you are using a signal generator for your signal source, then continue with the steps on this page.

1. Press the Channel 2 On button (A). The channel 2 trace is displayed along with the channel 1 signal.
2. Connect the X1 probe to the channel 2 (+) input BNC (B) and compensation point (C) similar to that as shown in Figure 1 on page 6-4.
3. Press the channel 2 Coupling button (D) until the AC coupling LED (E) lights.

4. Press the Live button (F). The sine wave input to channel 1 and the square wave input to channel 2 are now displayed.

The instrument is deriving triggers from the signal input to channel 1 because the "1" LED (G) above the trigger Source button is illuminated. Therefore, when a sweep is triggered on channel 1, then a sweep will also be triggered on channel 2.

5. Press the Hold Next button (H).
6. Disconnect the probe from the compensation point and channel 2 input BNC.

7. Press the channel 2 On button (A) to turn channel 2 off.
8. Press the channel 2 Coupling button (D) until the Gnd LED lights.

External Triggering

The trigger signal must meet minimum amplitude requirements when the signal is applied to the EXT input BNC.

A valid trigger input to the EXT input BNC will initiate sweeps on any channel(s) that is turned on.

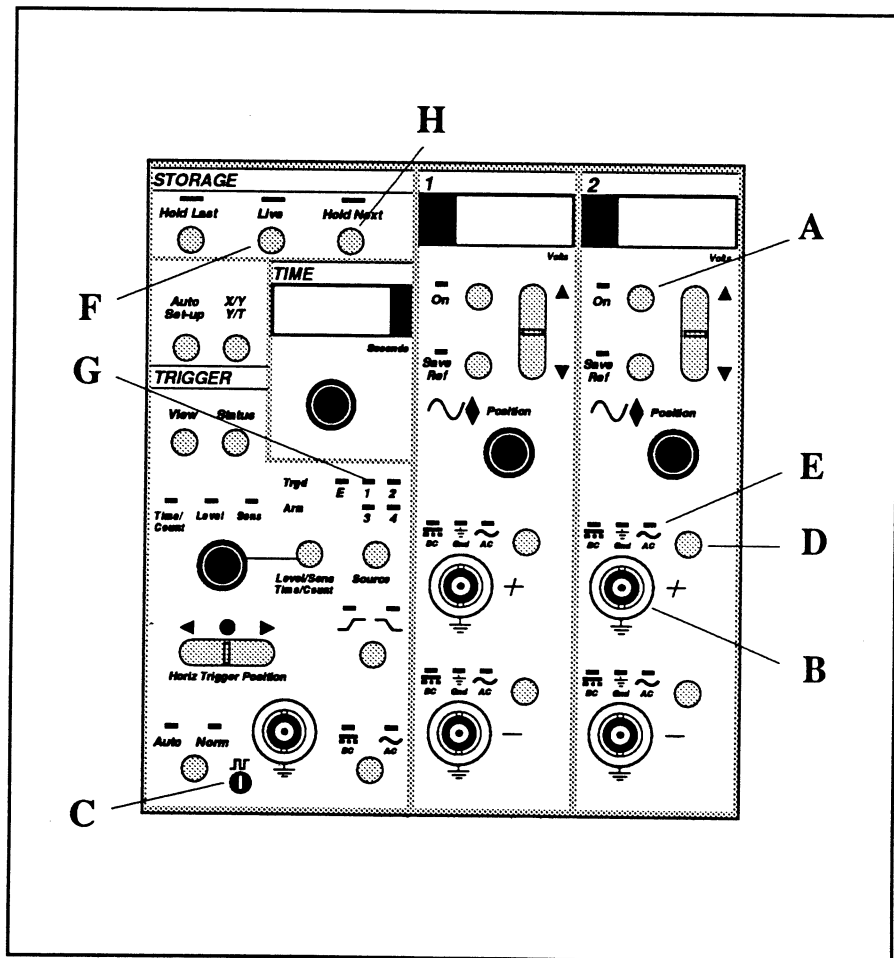

AUTO SET-UP BUTTON

The Auto Set-up button is used to automatically adjust the Volts, Time, trigger Level and Sensitivity values to the optimum settings for the signal being input as the trigger source.

Note: The signal must be repetitive at a frequency greater than 10 Hertz and 30 mVpp to use this feature.

1. Set the Channel 1 Volts readout for 30 volts.
2. Set the Time readout for 100n.
3. Adjust the Level/Sens control (A) clockwise until the trigger Level marker screen reaches the top edge of the screen (Figure 1).
4. Press the Level/Sens button (B) until the trigger Sens LED (C) lights.
5. Adjust the Level/Sens control (A) counterclockwise until the arrow shaft reaches the bottom of the screen (Figure 1).
6. Press the Live button (D). The instrument is unable to trigger any sweeps.
7. Press the Auto Set-up button (E). After several sweeps, the instrument will automatically adjust the trigger Level and Sensitivity values to the optimum values and readjust the Volts setting for the maximum full scale setting that will allow the signal to be viewed without exceeding the display limits and the Time setting to display four or five cycles.

Adjust the trigger Level (step 3) until the arrow reaches top edge of the screen.

Adjust the trigger Sens (step 5) until the arrow shaft reaches the bottom edge of the screen.

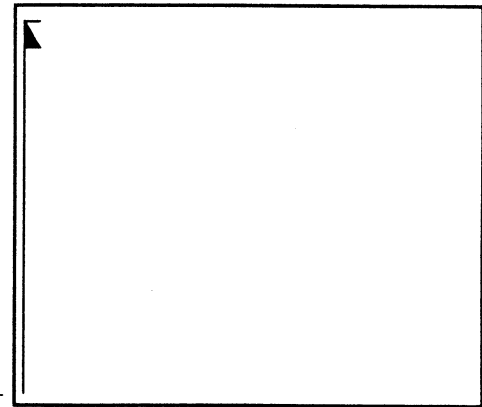
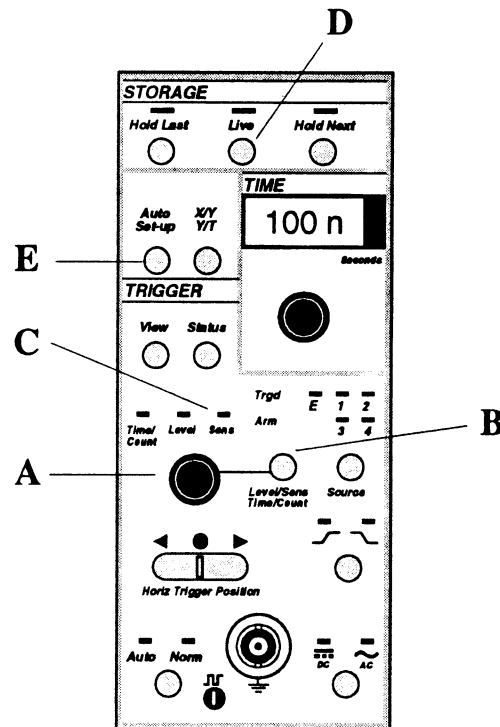

Figure 1



THE MENU BUTTON

The individual functions resident in memory will not be described here. However, use the following procedure to familiarize yourself with the available functions.

1. Press the Menu button (A).

A menu appears on the screen.

2. Press the Down Cursor button (B) several times while observing the screen. A submenu of functions appears on the right side of the screen as each category on the left side of the screen is highlighted.
3. Press the Right Cursor button (C). The cursor moves to the right column of functions.
4. Press the Down Cursor button (B). The cursor moves down the list of functions. During normal operations, you would press the Execute button (D) after the desired function has been selected. Some functions will prompt you to enter information. Refer to Chapter 14 in this manual for information on this feature.
5. Press the Left Cursor button (E). The cursor moves back to the left column of categories.
6. Press the Menu button (A). The waveform display returns.

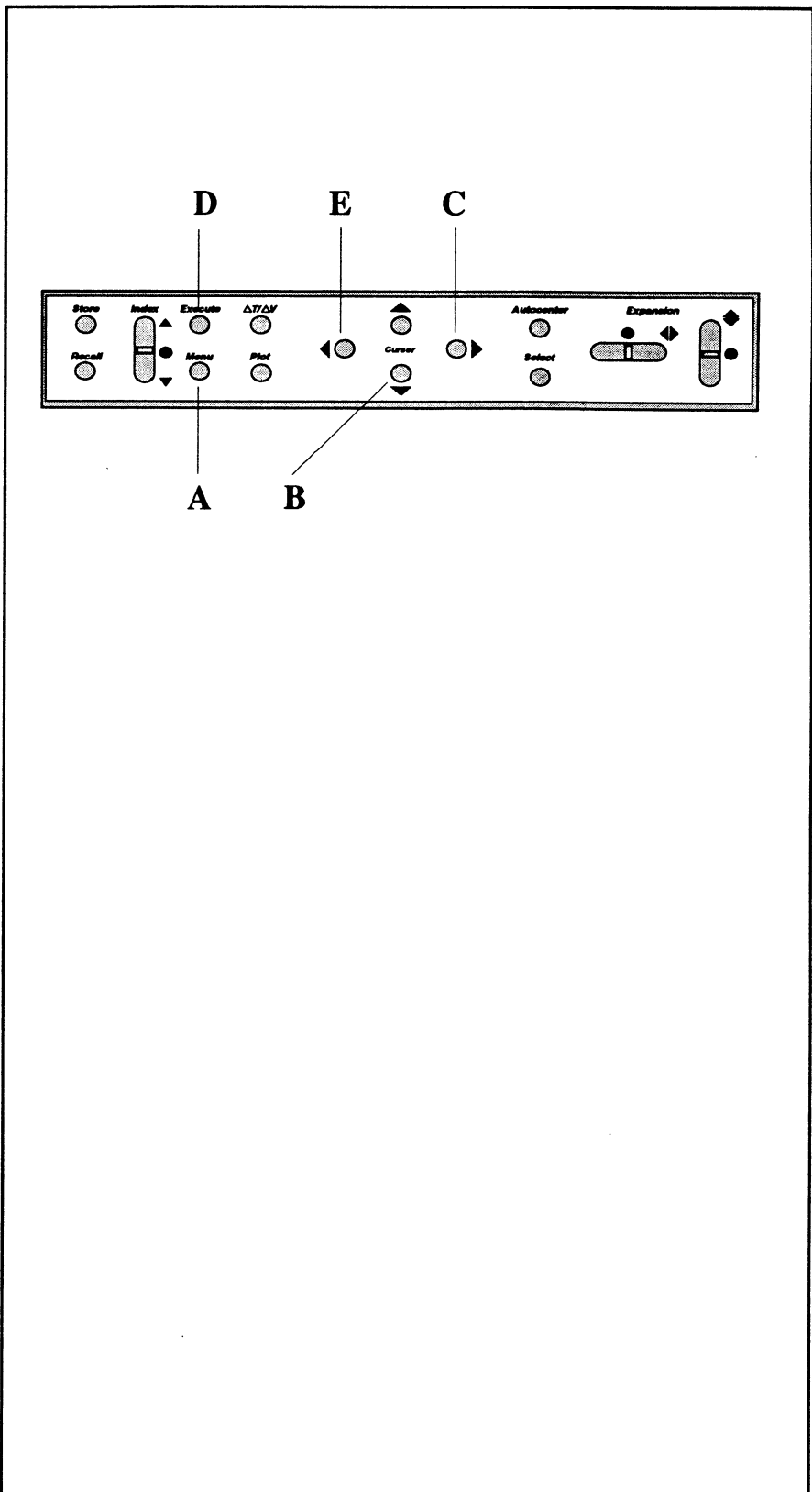

AUTO SET-UP BUTTON

The Auto Set-up button is used to automatically adjust the Volts, Time, trigger Level and Sensitivity values to the optimum settings for the signal being input as the trigger source.

Note: The signal must be repetitive at a frequency greater than 10 Hertz and 30 mVpp to use this feature.

1. Set the Channel 1 Volts readout for 30 volts.
2. Set the Time readout for 100n.
3. Adjust the Level/Sens control (A) clockwise until the trigger Level marker screen reaches the top edge of the screen (Figure 1).
4. Press the Level/Sens button (B) until the trigger Sens LED (C) lights.
5. Adjust the Level/Sens control (A) counterclockwise until the arrow shaft reaches the bottom of the screen (Figure 1).
6. Press the Live button (D). The instrument is unable to trigger any sweeps.
7. Press the Auto Set-up button (E). After several sweeps, the instrument will automatically adjust the trigger Level and Sensitivity values to the optimum values and readjust the Volts setting for the maximum full scale setting that will allow the signal to be viewed without exceeding the display limits and the Time setting to display four or five cycles.

Adjust the trigger Level (step 3) until the arrow reaches top edge of the screen.

Adjust the trigger Sens (step 5) until the arrow shaft reaches the bottom edge of the screen.

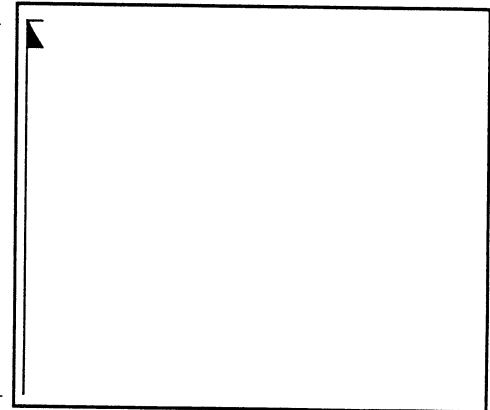
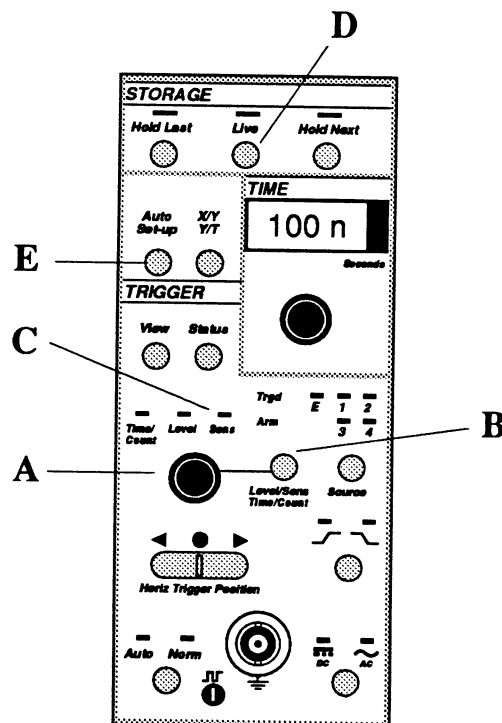

Figure 1



THE MENU BUTTON

The individual functions resident in memory will not be described here. However, use the following procedure to familiarize yourself with the available functions.

1. Press the Menu button (A).

A menu appears on the screen.

2. Press the Down Cursor button (B) several times while observing the screen. A submenu of functions appears on the right side of the screen as each category on the left side of the screen is highlighted.
3. Press the Right Cursor button (C). The cursor moves to the right column of functions.
4. Press the Down Cursor button (B). The cursor moves down the list of functions. During normal operations, you would press the Execute button (D) after the desired function has been selected. Some functions will prompt you to enter information. Refer to Chapter 14 in this manual for information on this feature.
5. Press the Left Cursor button (E). The cursor moves back to the left column of categories.
6. Press the Menu button (A). The waveform display returns.

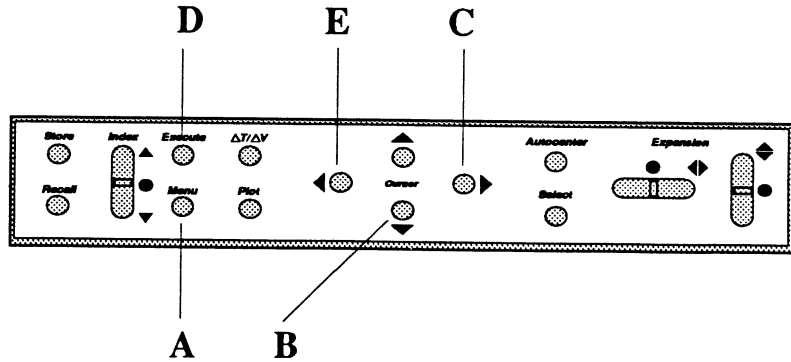

THE TRIGGER STATUS BUTTON

The Trigger Status screen can be viewed while in either the Live mode or the Hold mode (Live LED off, Hold Last LED on).

1. Press the Live button (A).
2. Press the Status button (B). The status' of various front panel controls appear on the Status screen. These are the currents settings being used to capture data. You can record these values and then reenter them later to quickly setup the instrument for duplicate acquisitions at a later time.
3. Press the Level/Sens button (C) until the Level LED lights.

Note: This button is also used to illuminate the Time/Count LED which is a function of the Advanced Trigger features. These features are discussed in *Chapter 18*.

4. Adjust the Trigger Level/Sens control (D) while observing the display. The new trigger Level value appears on the screen.
5. Press the Level/Sens button (C) until the Sens LED lights.
6. Adjust the Trigger Level/Sens control (D) while observing the display. The new trigger Sensitivity value appears on the screen.
7. Press the Status button (A). The waveform display returns.

THE TRIGGER VIEW BUTTON

The Trigger View screen displays pre-trigger events on the first 20% of the screen so you can see the events leading up to the trigger point while setting up the triggering parameters. It also shows you the Upper/Lower Trigger Levels and Trigger Sensitivity values.

1. Press the View button (E). The pretrigger display appears with the trigger Level and Sensitivity values displayed at the top of the screen.
2. Experiment with the various triggering controls while noting their effects on the displayed signal.
3. Press the View button to return to the normal waveform display.

THE HORIZ TRIGGER POSITION BUTTON

The Horizontal Trigger Position button (F) allows you to select delayed sweeps, pre-trigger or normal trigger acquisitions. These triggering modes are discussed in *Chapter 13*.

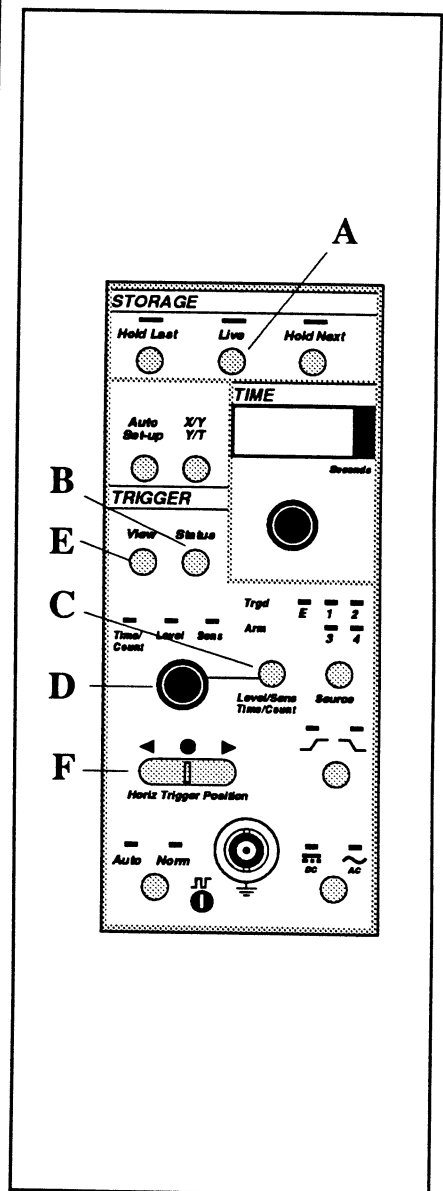

Chapter 7

THE DISPLAY SCREEN

YT Display Numerics	7-2
XY Display Numerics	7-2
Waveform	7-3
Vertical Cursor	7-3
Horizontal Cursor	7-3
Crosshair	7-3
Expansion Marker	7-4
Channel Identifier	7-4
Setup Trigger Marker	7-4
Data Trigger Marker	7-4
Positive Trigger Slope Marker	7-5
Negative Trigger Slope Marker	7-5
Dual Trigger Slope Marker	7-5
Trigger Level Marker	7-5
Trigger Sensitivity Marker	7-6
← (Trigger Off Screen Marker)	7-6
View	7-6
○ To Cursors=	7-6
Autocenter Marker	7-7
Cursor Time Lock Marker	7-7
Dot-Join Marker	7-7
Trigger OR Marker	7-7
Advanced Trigger Markers	7-8
Advanced Trigger ARM & TRG Markers	7-9

This chapter provides a general overview of the basic screen elements appearing on the display screen during various modes of operation.

Note: These descriptions are only very general summaries of the basic screen elements. Additional information for each of the screen elements and their applications are fully described in the chapters referenced above each of the screens.

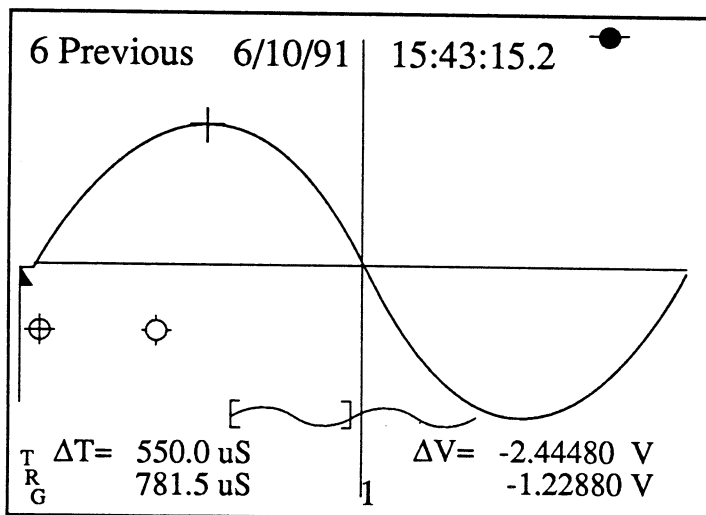

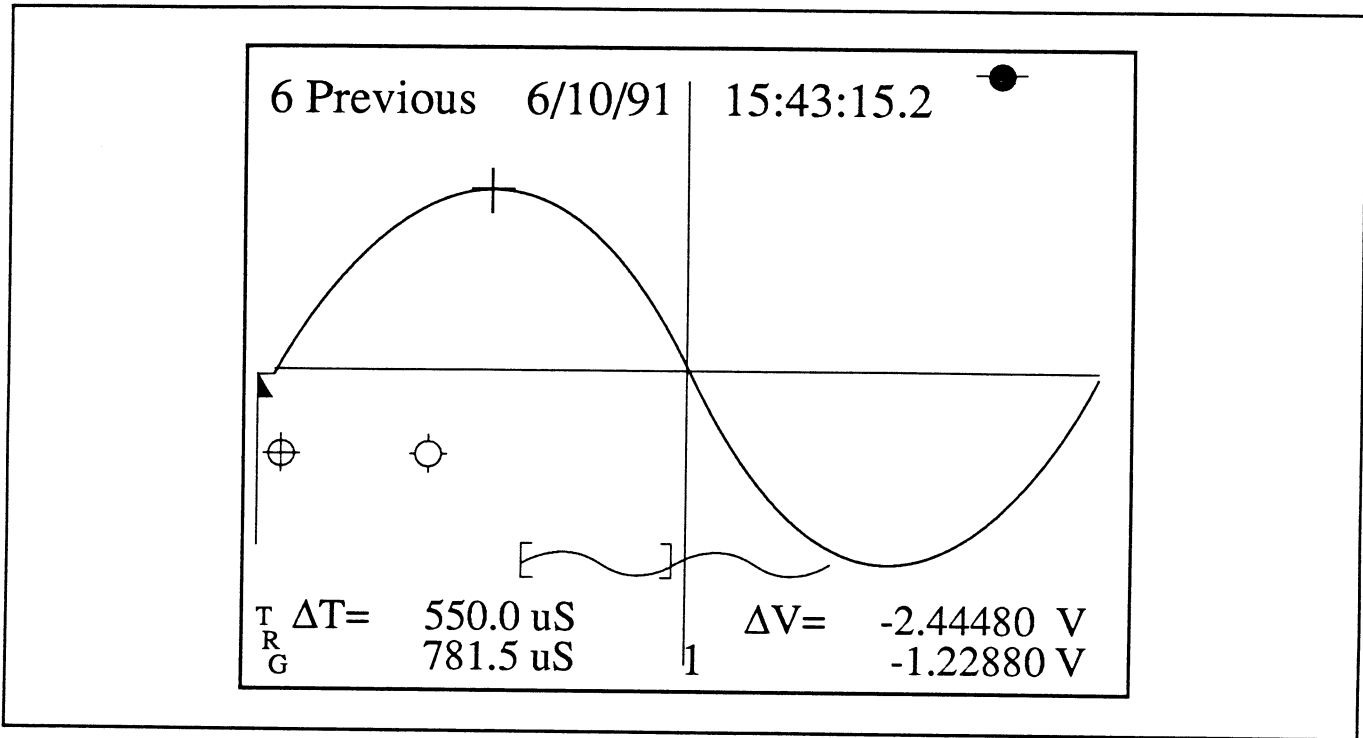

See Chapter 9

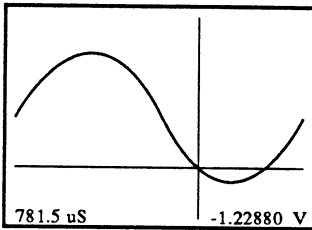

See Chapter 9

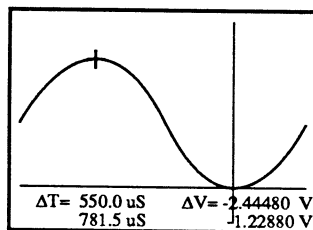

See Chapter 9

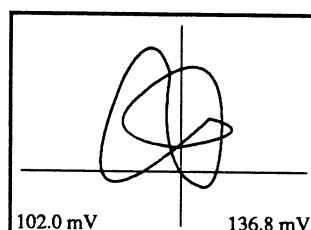

See Chapter 9

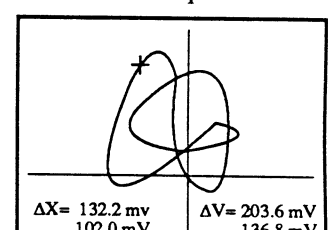

YT MODE NUMERICS

ΔT/ΔV Turned Off - The left numerics decodes the time coordinates and the right numerics decodes the voltage values of the selected data point.

You can customize the numerics with the User Units function (see Chapter 19 for more information).

ΔT/ΔV Turned On - The ΔT/ΔV marker (small crosshair) locates the new user-selected $t=0, v=0$ coordinates. The ΔT/ΔV numerics decode values with respect to this new $\Delta T=0, \Delta V=0$ coordinate.

The lower numerics continue to decode values with respect to the original $t=0, v=0$ origins.

XY MODE NUMERICS

ΔT/ΔV Turned Off - The left numerics decodes the X-axis' voltages and the right numerics decodes the Y-axis' voltages.

ΔT/ΔV Turned On - The ΔT/ΔV marker (small crosshair) locates the new user-selected $X=0, Y=0$ coordinates. The ΔT/ΔV numerics decode values with respect to this new $\Delta X=0, \Delta Y=0$ coordinate.

The lower numerics continue to decode values with respect to the original $X=0, Y=0$ origins.

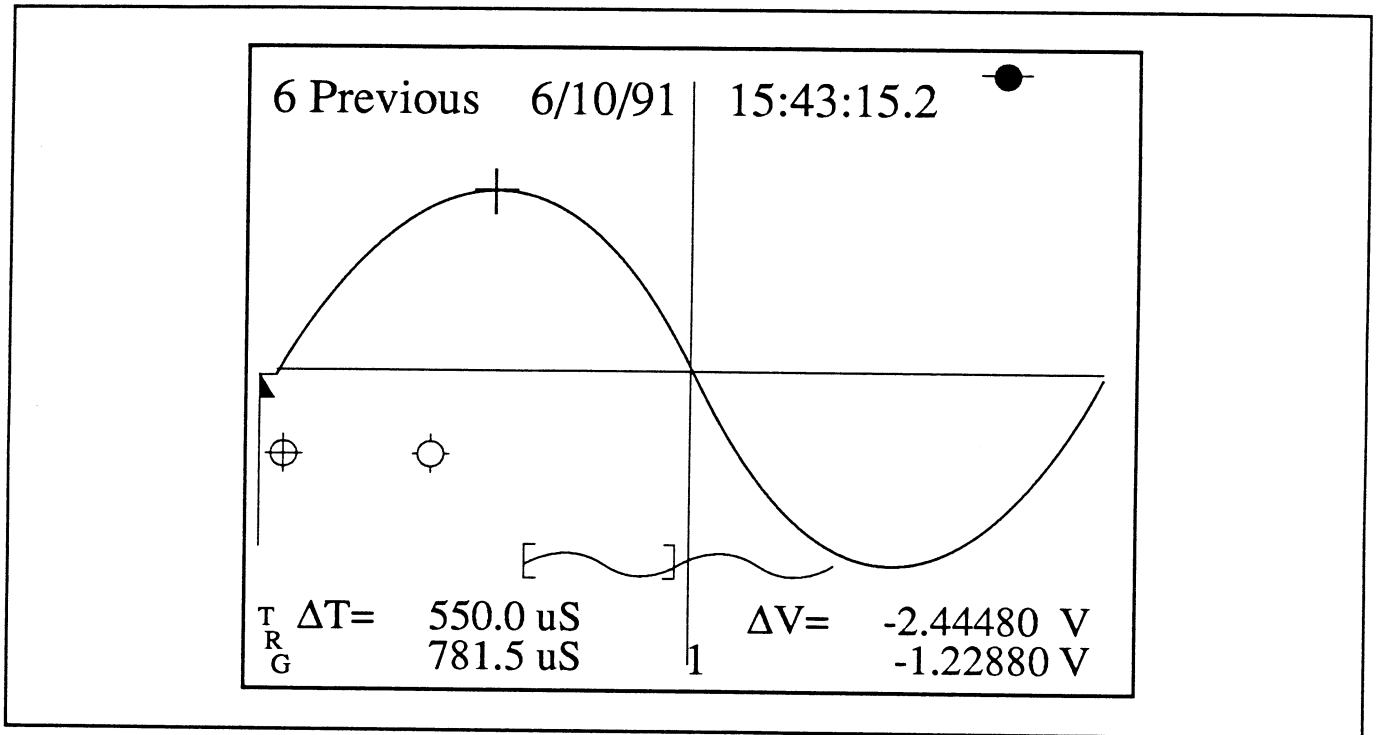

See Chapters 8, 10

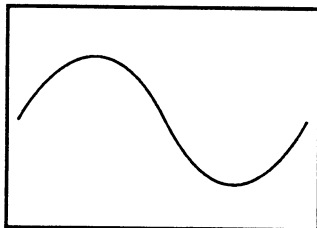

WAVEFORM

Displayed input signal comprised of small dots referred to as "data points".

Each data point represents a discrete digitized time and voltage value of the analog input signal.

You can select view the discrete data points which become visible with display expansion applied, or connect adjacent data points with a line using the Dot-Join function (pg. 7-7).

See Chapter 9

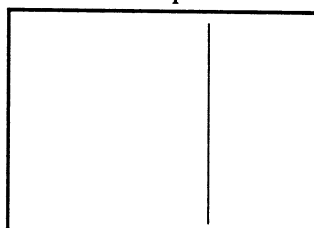

VERTICAL CURSOR

Selects which data point will be decoded by the left numerics.

Horizontal expansion locks the crosshair at screen horizontal center.

See Chapter 9

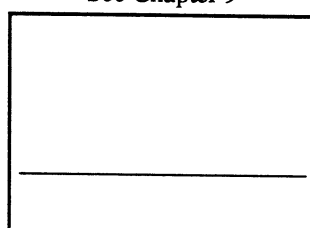

HORIZONTAL CURSOR

Selects which data point will be decoded by the right numerics.

Vertical expansion locks the crosshair at screen vertical center.

See Chapter 9

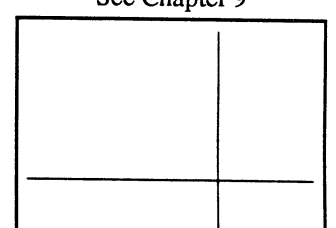

CROSSHAIR

Both cursors become interactive when Autocenter is turned on. This allows the waveform to be traced, thus providing single-button selection of data points for decoding by the numerics.

Applying horizontal and vertical expansion causes the crosshair to lock at screen center.

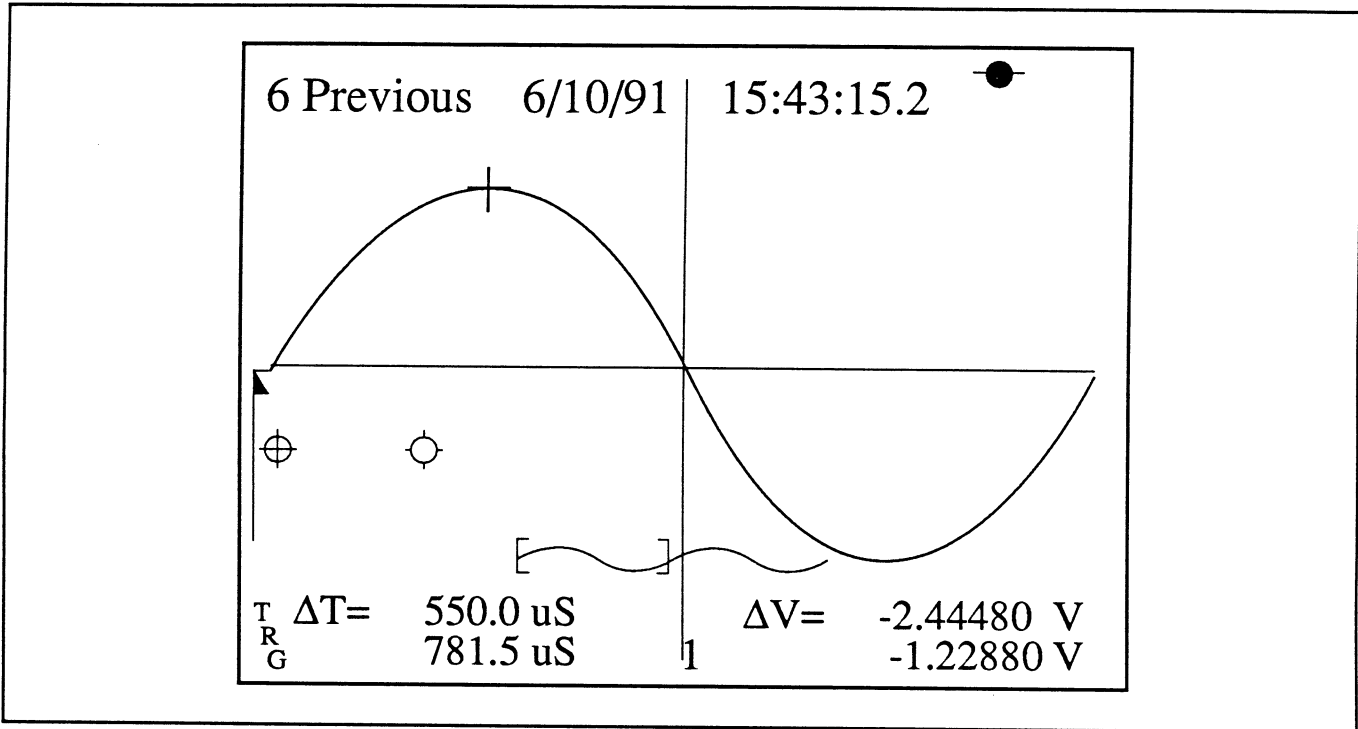

See Chapter 9

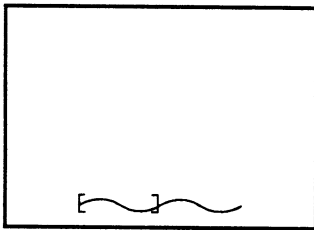

EXPANSION MARKER

The horizontal line represents one full sweep. The distance between the two brackets decreases as you increase horizontal expansion. Increasing vertical expansion causes the height of the brackets to decrease.

See Chapter 9

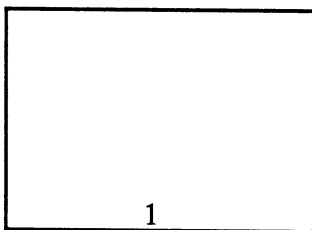

CHANNEL IDENTIFIER

Identifies which channel captured the waveform selected for inspection. The selected waveform shows brighter on the screen. An "S" suffix indicates that the waveform is "saved" (e.g., 1S).

See Chapter 13

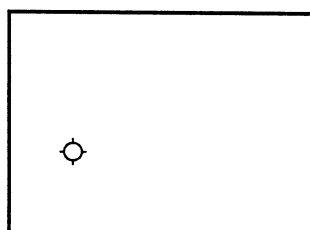

SETUP TRIGGER MARKER

An empty circle marks the selected trigger time (t=0) coordinate that will be used for the next sweep.

See Chapter 13

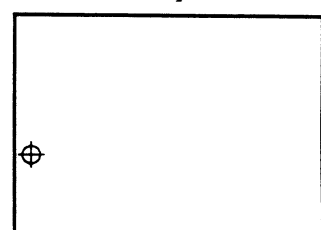

DATA TRIGGER MARKER

A circle filled with a crosshair marks the trigger time (t=0) coordinate of the last sweep.

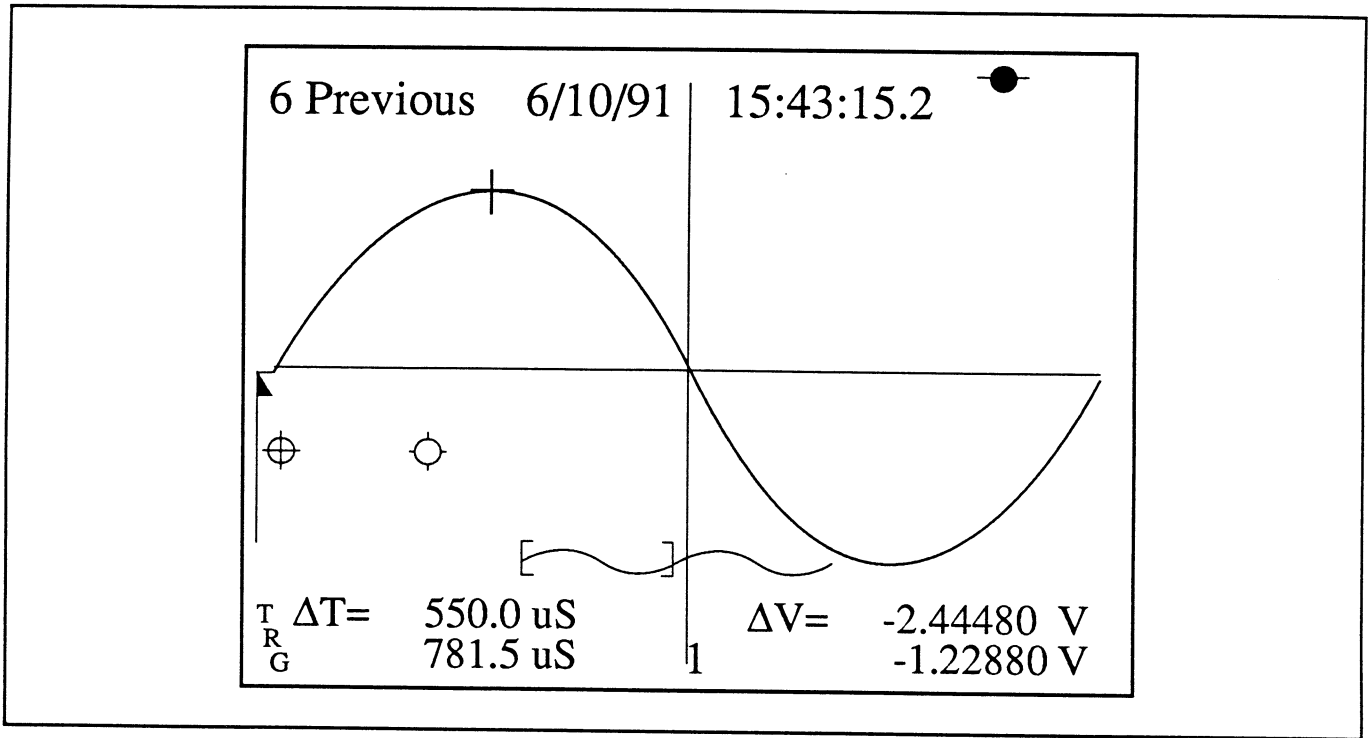

See Chapter 13

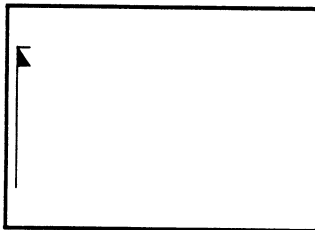

POSITIVE TRIGGER SLOPE MARKER

Only increasing voltages qualify as valid triggers.

See Chapter 13

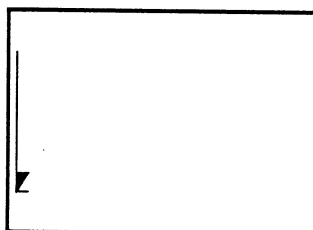

NEGATIVE TRIGGER SLOPE MARKER

Only decreasing voltages qualify as valid triggers.

See Chapter 13

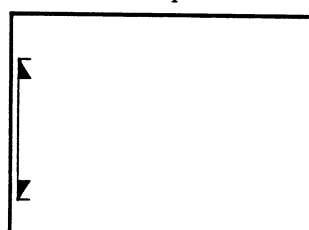

DUAL TRIGGER SLOPE MARKER

Either increasing or decreasing voltages qualify as valid triggers.

See Chapter 13

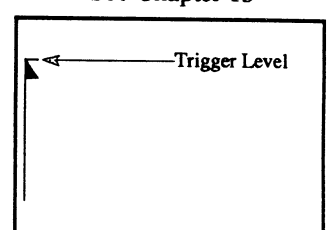

TRIGGER LEVEL MARKER

The tip of the arrow shows the selected trigger level across which the signal must cross to qualify as a valid trigger.

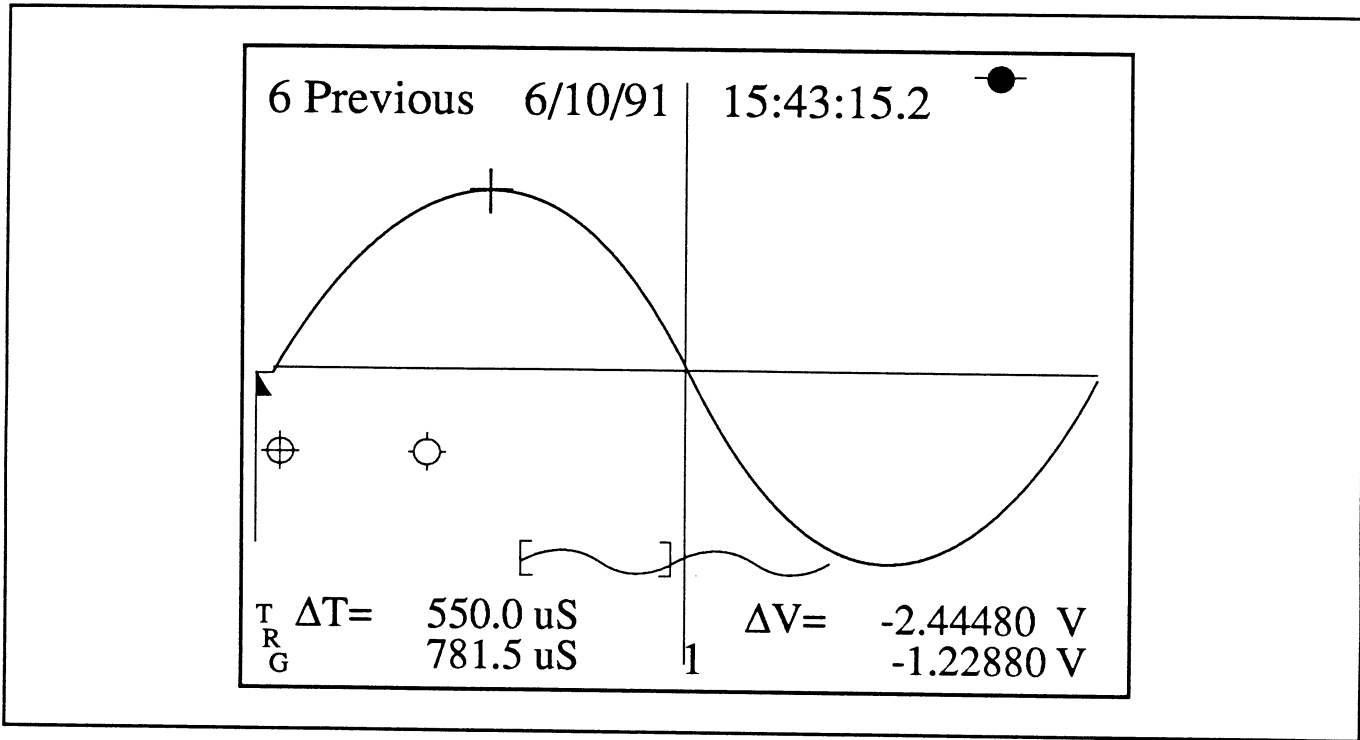

See Chapter 13

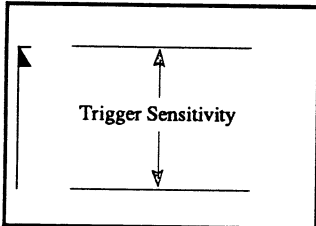

TRIGGER SENSITIVITY MARKER

The distance between the top and bottom of the marker indicates the trigger sensitivity through which the triggering signal must pass to qualify as a valid trigger.

See Chapter 13

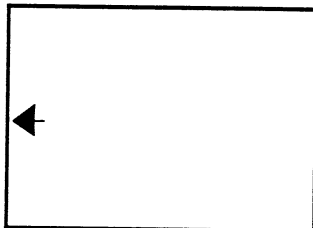

DELAYED SWEEP MARKER

← appears at the left edge of the screen when Delayed Sweeps are being used to capture data or when horizontal expansion has forced the trigger point off screen. The vertical position of the arrow on the screen marks the digital zero level reference. The Data Trigger Marker disappears from the screen when this symbol appears.

See Chapter 13

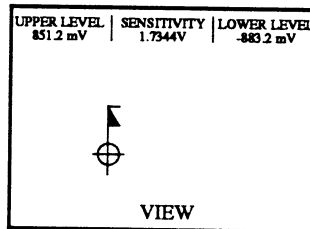

VIEW

VIEW appears when the View Mode is turned on. The View mode allows you to quickly view pre-trigger data leading up to the trigger and experiment with new trigger point (t=0) positions without affecting the original t=0 position.

The trigger Upper Level, Sensitivity, and Lower Level values appear at the top of the screen.

See Chapter 13

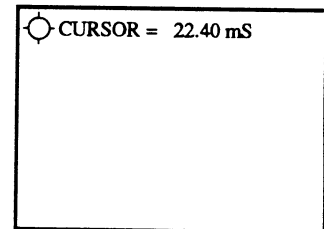

TO CURSOR=

To Cursor= appears when in the Hold Last mode and you are setting up for a Delayed sweep or a Mid Trigger sweep acquisition. It displays the current time between the position of the vertical cursor and the Setup Trigger Marker.

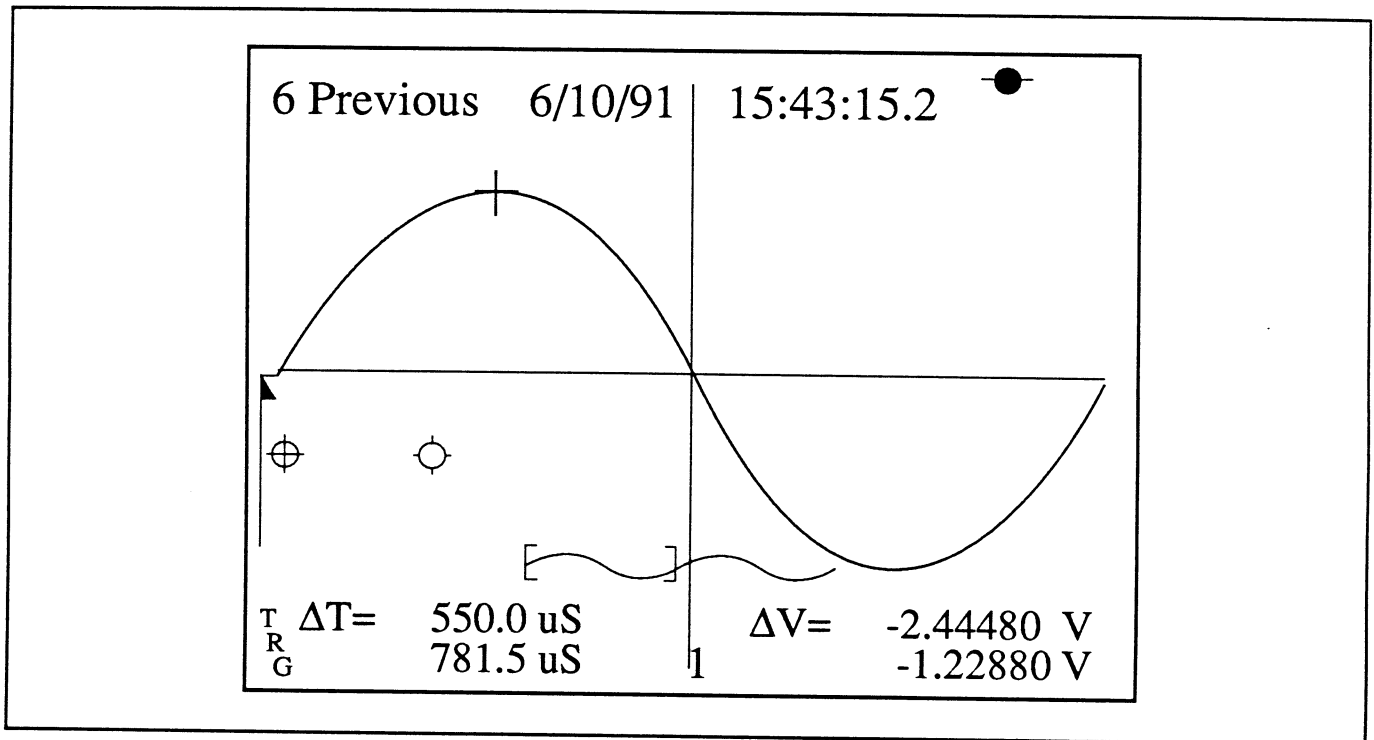

See Chapter 9

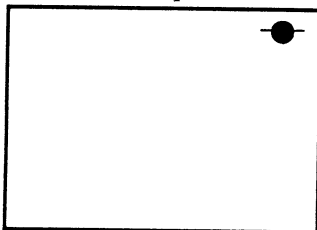

AUTOCENTER MARKER

The Autocenter Marker appears at the top right of the screen when Autocenter is turned on.

Note: Pressing the Up or Down Cursor buttons automatically turns off the Autocenter mode.

See Chapter 19

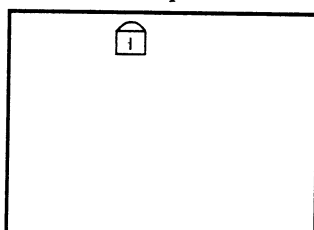

CURSOR TIME LOCK MARKER

A lock appears on the screen when the Cursor Time Lock function (accessed via the Menu button) is turned on. This function allows the instrument to maintain a constant time interval between the trigger and the position of the vertical cursor when either the Sweep Length or Time setting is changed.

See Chapter 20

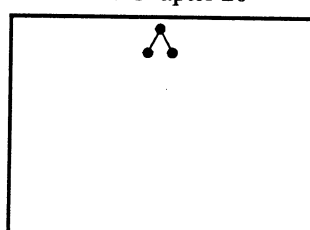

DOT-JOIN MARKER

The Dot-Join Marker appears when you turn on the Dot-Join function. Dot-Join is used to connect adjacent data points with line segments to enhance your ability to view expanded waveforms while in the Hold Last mode (Live LED off, Hold Last LED on).

See Chapter 19

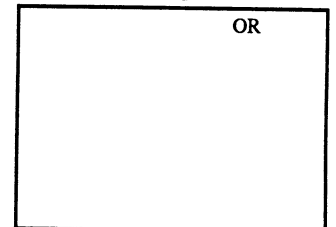

TRIGGER OR MARKER

The word OR appears when two or more channels (and/or External input BNC) have been 'ORed' together as trigger sources. A valid trigger input to any of the ORed input BNCs will trigger a sweep on all channels included in the OR configuration.

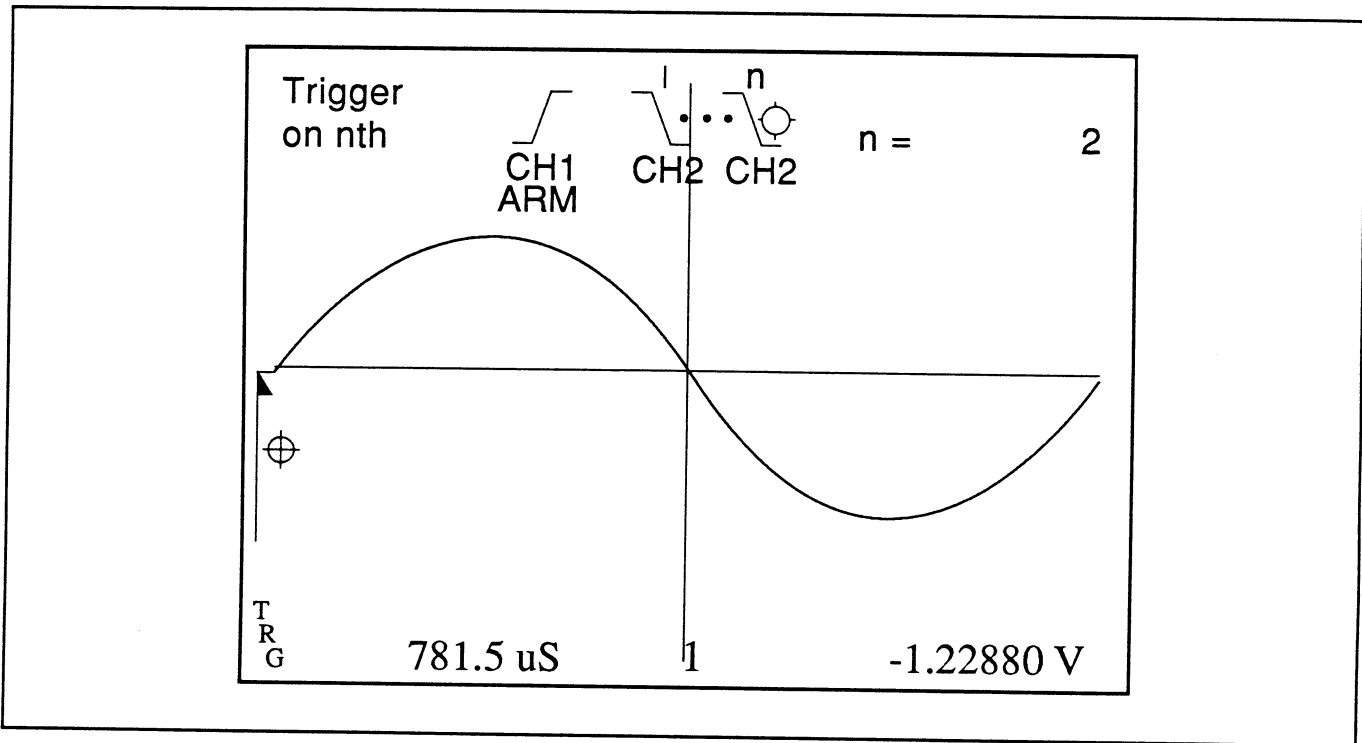

See Chapter 18

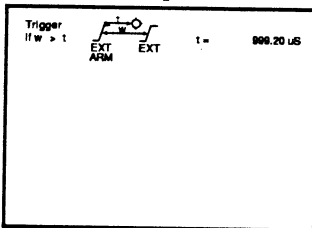

See Chapter 18

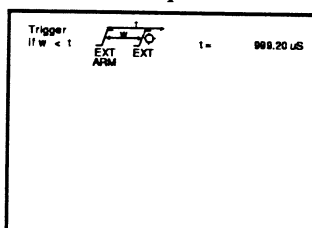

See Chapter 18

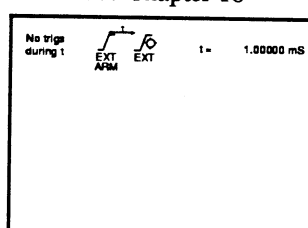

See Chapter 18

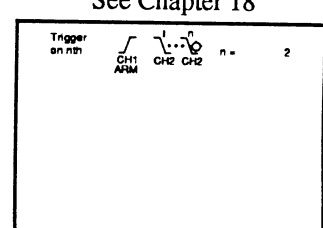

GLITCH TRIGGERING MARKER

An Advanced Trigger function. Requires two qualified events to trigger a sweep. The first event starts a user-defined timer. A sweep is triggered if the second event occurs before the timer times out.

DROP OUT TRIGGERING MARKER

An Advanced Trigger function. Requires two qualified events to trigger a sweep. The first event starts a user-defined timer. A sweep is triggered if the timer times out before the second event occurs.

HOLD OFF TRIGGERING MARKER

An Advanced Trigger function. Requires two qualified events. The first event starts a user-defined timer. All qualified events are ignored while the timer is timing. A sweep is triggered by the first valid event to occur after the timer times out.

n EVENT TRIGGERING MARKER

An Advanced Trigger function. A sweep is triggered when the number of qualified events equals a user-defined counter.

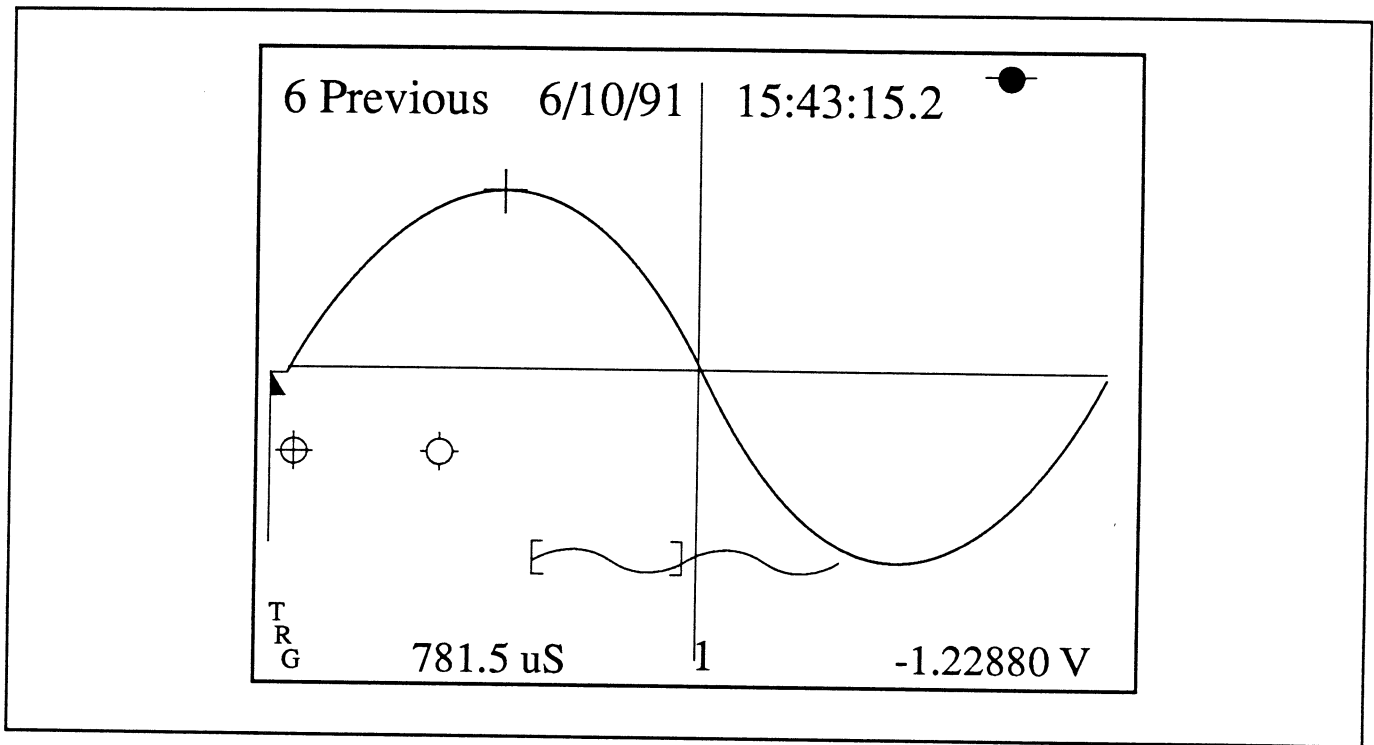

See Chapter 18

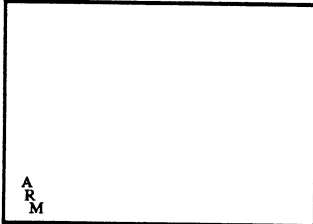

ADVANCED TRIGGER ARM MARKER

The front panel trigger controls are set for adjusting the Advanced Trigger function's ARM signal. Press the trigger Source button to select the TRG signal.

See Chapter 18

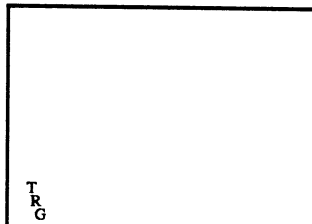

ADVANCED TRIGGER TRG MARKER

The front panel trigger controls are set for adjusting the Advanced Trigger function's TRG signal. Press the trigger Source button to select the ARM signal.

Chapter 8

THE STORAGE CONTROLS

Live Button	8-3
Hold Last Button	8-4
Hold Next Button	8-5
The Hold Mode	8-6
• Clearing the Status Line	8-6
Aborting a Long Sweep	8-6
Guarding Stored Data	8-6
The Sweep Review Memory	8-7

This chapter describes the controls and procedures that allow the instrument to capture live signals for display and store the digitized data in memory.

It also describes the Sweep Review Memory feature. Also see *Chapter 17*.

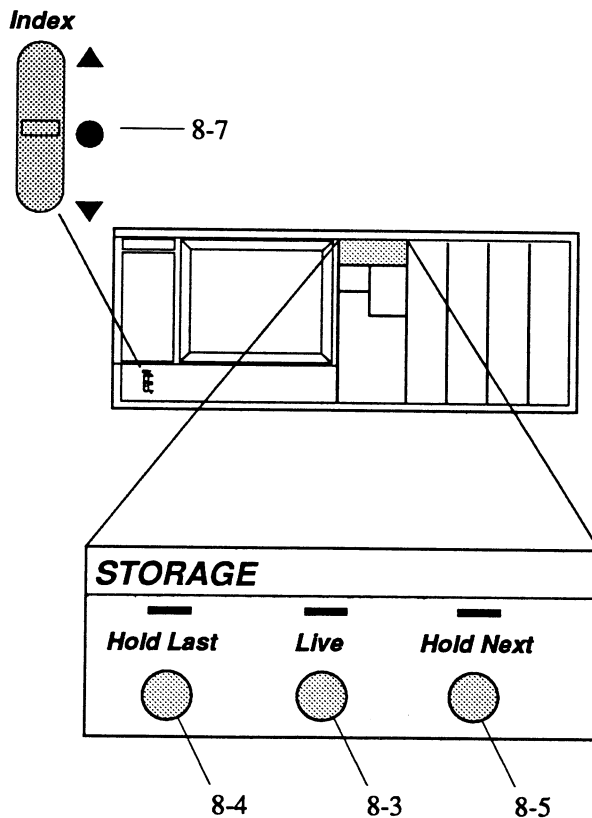

THE LIVE BUTTON

Press the Live button (Live Mode) to capture data each time a new sweep is triggered. The captured data is displayed on the screen at the end of each sweep and the data captured during the previous sweep is stored in the Sweep Review memory.

Note: The Sweep Review memory allows you to review data captured during the x-number of previous sweeps. The maximum number of sweeps that can be stored in the Sweep Review memory depends on the number of data points per sweep entered via the Sweep Length function. See page 8-7 in this chapter for additional information about Sweep Review.

You must turn on each channel that will be used to capture data. For example, if channels 1, 2 and 4 are turned on and channel 3 is turned off when a valid trigger is received, then only channels 1, 2 and 4 will capture new data.

Note: If the Live button is accidentally pressed, thus arming the system, you can disarm it again if you press the Hold Last button before a sweep is triggered.

Important: Sweeps are aborted if the TIME/DIV setting is changed, or the Live, Auto Set-up, View, Channel ON/OFF, Store, Recall, Menu or Plot buttons are pressed (Figure 2). Any data captured before you abort the sweep is stored in the Sweep Review Memory.

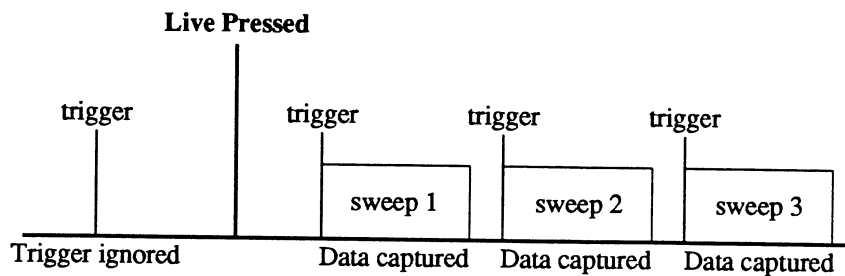

Figure 1 - The Live button was pressed, thus arming the instrument to start a sweep each time a valid trigger is received.

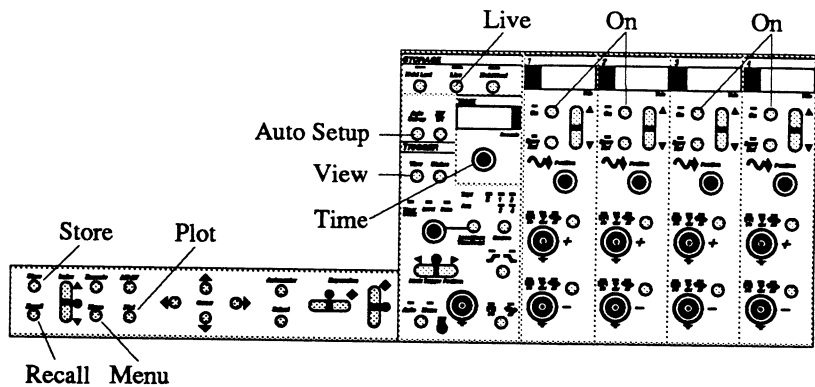

Figure 2 - Operate any of the indicated front panel controls to abort a sweep in progress.

THE HOLD LAST BUTTON

How the Hold Last Mode operates depends upon whether a sweep is in progress when you press the Hold Last button.

Sweep in Progress

Pressing the Hold Last button during a sweep:

1. Allows the current sweep to complete and then stores the newly captured data.
2. Prevents any new sweeps from being triggered.

Between Sweeps

Pressing the Hold Last button when the instrument is between sweeps:

1. Stores the data captured during the previous sweep.
2. Prevents any new sweeps from being triggered.

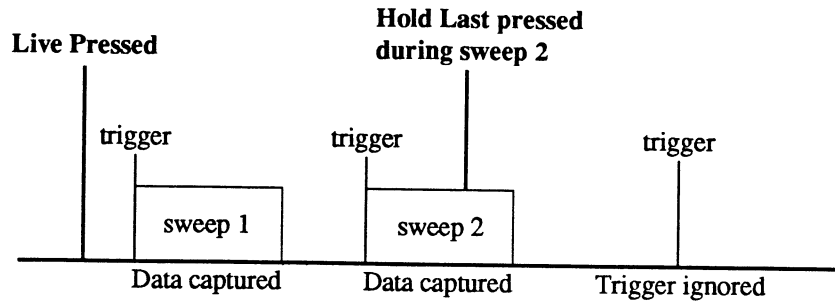

Figure 1 - Hold Last was pressed during the second sweep. The second sweep is allowed to complete and the captured data remains displayed on the screen.

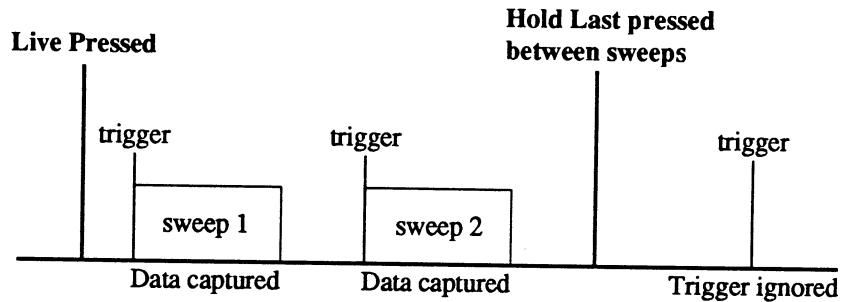

Figure 2 - Hold Last was pressed between sweeps. Data captured during second sweep remains displayed on the screen.

THE HOLD NEXT BUTTON

The Hold Next button arms the Hold Next Mode which allows the instrument to initiate a sweep when the next valid trigger occurs. When this final sweep is completed, the captured data remains displayed on the screen and the instrument is disarmed from taking any more sweeps.

Figures 1, 2 and 3 show that regardless of the instrument's state, pressing the Hold Next button arms the instrument to recognize only one more valid trigger. Once the final sweep is completed, the instrument is disarmed.

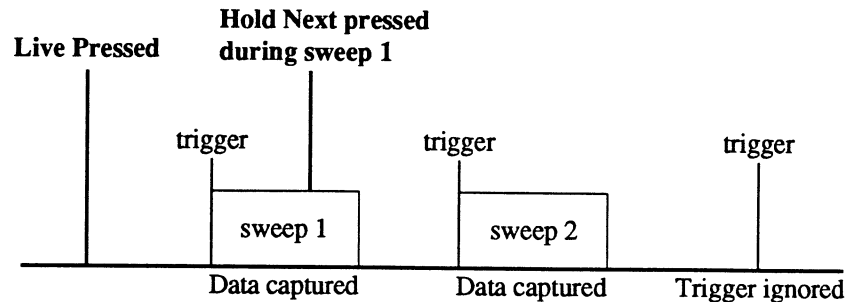

Figure 1 - Hold Next was pressed during the first sweep while in the Live mode. The first sweep was completed and the next valid trigger was allowed to trigger the second sweep. Data captured during the second sweep remains displayed on the screen.

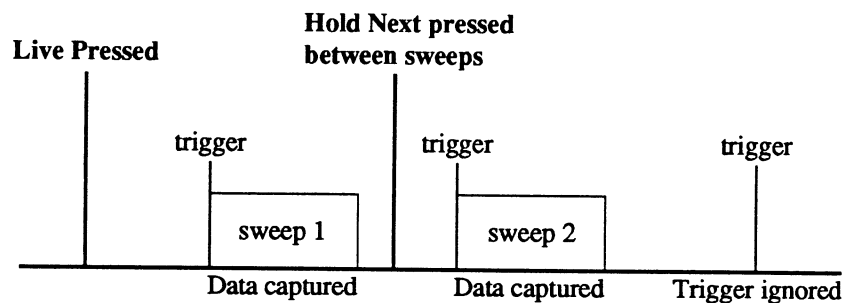

Figure 2 - Hold Next was pressed between sweeps while in the Live mode. The next valid trigger was allowed to trigger the second sweep. Data captured during the second sweep remains displayed on the screen.

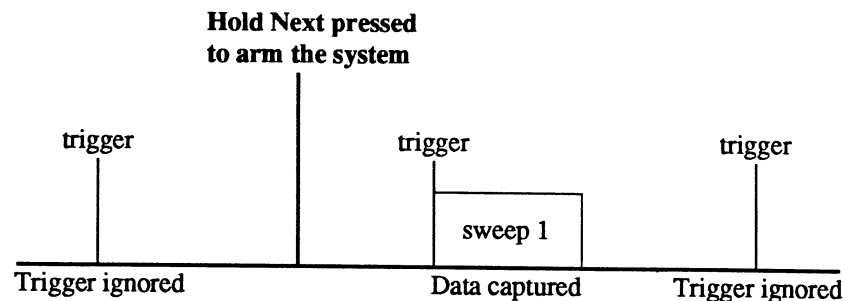

Figure 3 - Hold Next was pressed while in the Hold Mode (Hold Last LED on, Live LED off). Data captured during sweep 1 remains displayed on the screen.

THE HOLD MODE

The term Hold Mode is used throughout this manual to designate that the Hold Last LED is on and the Live LED is off. Sweeps cannot be triggered while the instrument is in the Hold Mode.

Clearing the Status Line

Pressing the Hold Last button while in the Hold Mode clears the Status Line at the top of the screen (Figure 1). The Status Line is used to display information, results and error messages.

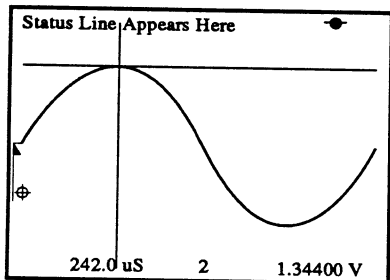

Figure 1 - The Status Line appears at the top of the screen.

ABORTING A LONG SWEEP

The Abort Mode stops a long sweep when a full sweep is not required.

Important: Aborted sweeps can consist of both old and new data.

To Abort a Long Sweep:

1. Press and hold the Hold Last button.
2. Press and release the Live button.
3. Release the Hold Last button.

The instrument is now in the Hold Mode (Hold Last LED on, Live LED off). Data captured during the aborted sweep is displayed along with data captured during the previous sweep.

GUARDING STORED DATA

Important: Data stored in memory is lost if any of the conditions below occur. Therefore, it is advisable to immediately store important data on disk as soon as possible to avoid accidental loss.

Data stored in memory is replaced if any of these events occur -

- a. The Live or Hold Next buttons are pressed and a new sweep is triggered.

Note: Data captured during the previous sweep will remain stored in the Sweep Review memory, but the oldest sweep that was stored in the memory will be discarded if the memory was full. See *page 8-7*, Sweep Review Memory.

- b. An executed Menu function stores its results to the selected memory section.

For example, the original waveform stored in channel 2 will be lost if the ADD function is used to add channel 1 to channel 2 and the result is stored in channel 2.

- c. Power is removed from the instrument.

SWEEP REVIEW MEMORY

The Sweep Review memory maintains an archive of past sweeps from which you can select for display. The number of sweeps you can store in the Sweep Review memory depends on the number of data points entered for the Sweep Length function (*Chapter 17*) and whether Save Referenced waveforms are being stored.

Note: The instrument must be in the Hold Mode (Hold Last LED on, Live LED off).

Entering the Sweep Review Mode

To review previously captured sweeps, press the top or bottom of the Index button.

Note: You can scan through the Sweep Review memory by holding in the Index button. The Sweep Review memory will continually wrap-around until you release the button. A beep will sound and the system will pause each time the "current" sweep display is reached.

Data captured during the previous sweeps will appear on the screen. The Status Line at the top of the screen shows which sweep is being viewed, the maximum number of sweeps that can be stored in the Sweep Review memory, and the date and time the sweep was captured.

Up to eight waveforms (sweeps) can be recalled by using all four channels and their Save Ref buttons if the instrument is configured with four channels. To view the most recent sweep in the archive, press the center of the Index button.

See the examples on the next page.

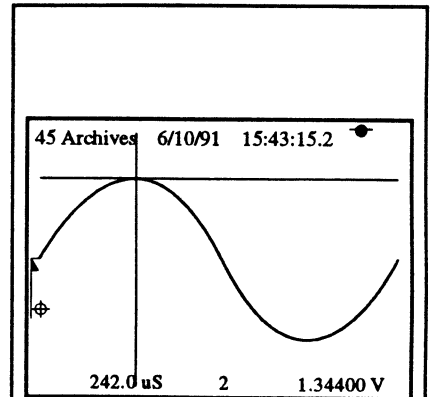

Figure 1 - The center of the Index button was pressed once while in the Hold Mode (Hold Last LED on, Live LED off) to display the data captured during the most current sweep. There are currently 45 archived sweeps in storage.

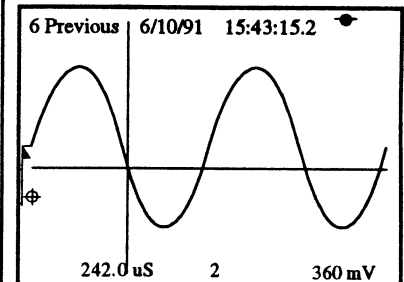

Figure 2 - The (-) side of the Index button was pressed and held until the seventh sweep (6 previous) appeared on the screen.

How Sweep Review Works

The Sweep Review memory is comprised of x-number of memory allocations which are used to archive sweeps. The maximum number allowed is determined by the number of data points assigned for the Sweep Length function (*Chapter 17*) and whether Save Referenced waveforms are allowed.

As each new sweep is triggered by a valid trigger, the previous sweep is inserted into the string of archived sweeps. Eventually, the Sweep Review memory is filled and will have to begin discarding the oldest sweep to make room for each newer sweep (Figure 5).

The Index button allows you to select any archived sweep for display on the screen.

IMPORTANT: If you recall a waveform from a storage media (e.g., floppy disk, hard drive, etc.) while in the Sweep Review memory mode, the data stored in the current sweep location will be replaced. For example, if you are viewing sweep location 10 and recall a waveform, then the data stored in sweep location 10 will be discarded and replaced with the newly recalled waveform.

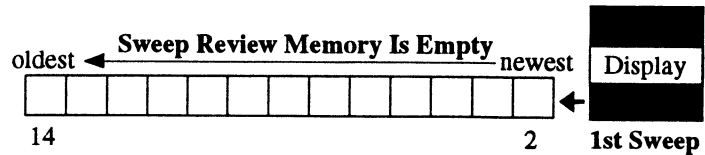

Figure 1 - For this example, assume that 13 sweeps can be archived and the Sweep Review Memory is empty. The following figures will track the first sweep (represented by the black box above) as each new sweep is triggered.

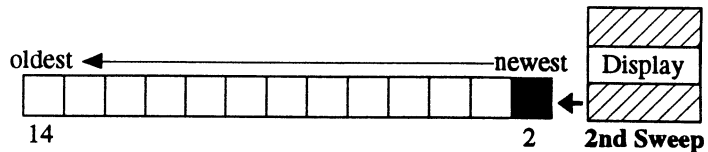

Figure 2 - The second sweep was triggered which caused the first sweep to move into Sweep Review memory location 2.

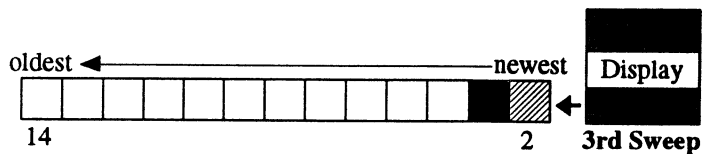

Figure 3 - The third sweep was triggered which moved the first sweep into memory location 3 and the second sweep into memory location 2.

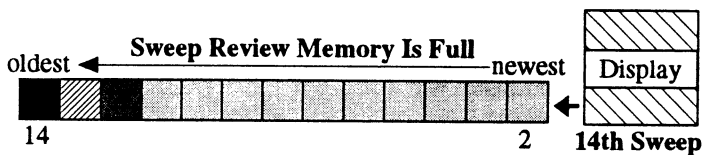

Figure 4 - After fourteen sweeps, all thirteen memory locations (2 - 14) contain data and the instrument is waiting for the 15th sweep.

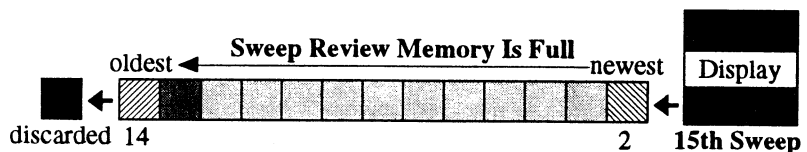

Figure 5 - The 15th sweep was triggered. This forced the memory to discard the first sweep (black box) to make room for the 14th sweep.

SWEEP REVIEW MEMORY

The Sweep Review memory maintains an archive of past sweeps from which you can select for display. The number of sweeps you can store in the Sweep Review memory depends on the number of data points entered for the Sweep Length function (*Chapter 17*) and whether Save Referenced waveforms are being stored.

Note: The instrument must be in the Hold Mode (Hold Last LED on, Live LED off).

Entering the Sweep Review Mode

To review previously captured sweeps, press the left or right side of the Index button.

Note: You can scan through the Sweep Review memory by holding in the Index button. The Sweep Review memory will continually wrap-around until you release the button. A beep will sound and the system will pause each time the "current" sweep display is reached.

Data captured during the previous sweeps will appear on the screen. The Status Line at the top of the screen shows which sweep is being viewed, the maximum number of sweeps that can be stored in the Sweep Review memory, and the date and time the sweep was captured.

Up to eight waveforms (sweeps) can be recalled by using all four channels and their Save Ref buttons if the instrument is configured with four channels. To view the most recent sweep in the archive, press the center of the Index button.

See the examples on the next page.

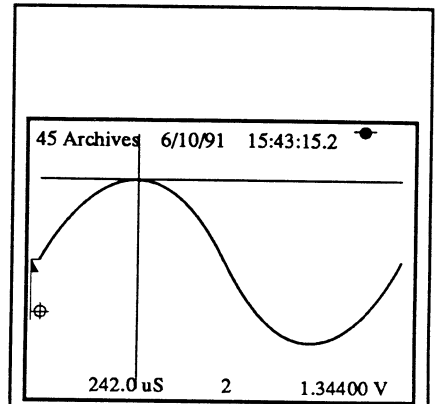

Figure 1 - The center of the Index button was pressed once while in the Hold Mode (Hold Last LED on, Live LED off) to display the data captured during the most current sweep. There are currently 45 archived sweeps in storage.

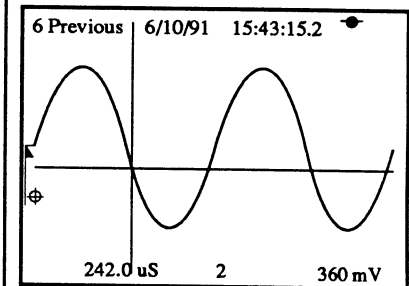

Figure 2 - The (-) side of the Index button was pressed and held until the seventh sweep (6 previous) appeared on the screen.

How Sweep Review Works

The Sweep Review memory is comprised of x-number of memory allocations which are used to archive sweeps. The maximum number allowed is determined by the number of data points assigned for the Sweep Length function (*Chapter 17*) and whether Save Referenced waveforms are allowed.

As each new sweep is triggered by a valid trigger, the previous sweep is inserted into the string of archived sweeps. Eventually, the Sweep Review memory is filled and will have to begin discarding the oldest sweep to make room for each newer sweep (Figure 5).

The Index button allows you to select any archived sweep for display on the screen.

IMPORTANT: If you recall a waveform from a storage media (e.g., floppy disk, hard drive, etc.) while in the Sweep Review memory mode, the data stored in the current sweep location will be replaced. For example, if you are viewing sweep location 10 and recall a waveform, then the data stored in sweep location 10 will be discarded and replaced with the newly recalled waveform.

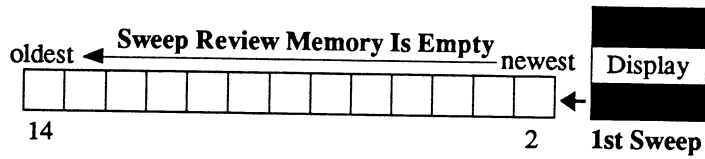

Figure 1 - For this example, assume that 13 sweeps can be archived and the Sweep Review Memory is empty. The following figures will track the first sweep (represented by the black box above) as each new sweep is triggered.

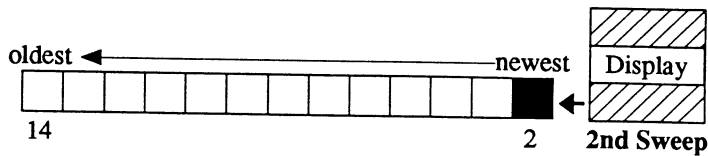

Figure 2 - The second sweep was triggered which caused the first sweep to move into Sweep Review memory location 2.

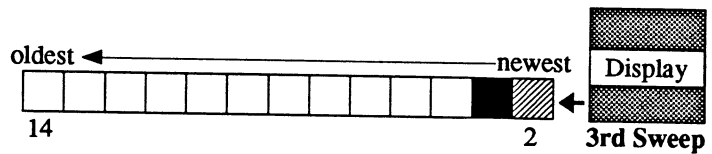

Figure 3 - The third sweep was triggered which moved the first sweep into memory location 3 and the second sweep into memory location 2.

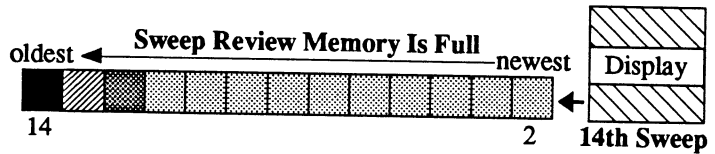

Figure 4 - After fourteen sweeps, all thirteen memory locations (2 - 14) contain data and the instrument is waiting for the 15th sweep.

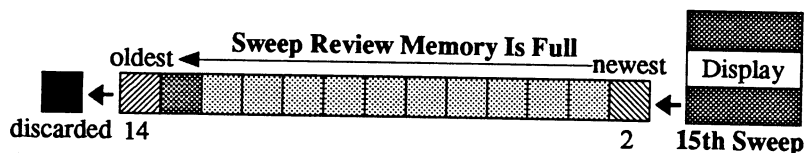

Figure 5 - The 15th sweep was triggered. This forced the memory to discard the first sweep (black box) to make room for the 14th sweep.

Chapter 9

THE DISPLAY CONTROLS

Up/Down Cursor Buttons	9-3
Selecting the Cursor Speed & Wrapping-Around the Cursors	9-6
Left/Right Cursor Buttons	9-4
Selecting the Cursor Speed & Wrapping-Around the Cursors	9-6
Introduction to Display Expansion	9-7
Setting the Expansion Defaults	9-7
More About the Expansion Marker	9-9
Inspecting Expanded Waveforms	9-10
Horizontal Expansion Button	9-11
Setting/Recalling the Expansion Defaults	9-13
Vertical Expansion Button	9-12
Setting/Recalling the Expansion Defaults	9-13
Autocenter Button	9-14
Moving the Cursors Independently of Each Other	9-15
Tracing the Waveform with the Crosshair	9-15
Moving the Waveform Through Screen Center	9-15
Select Button	9-16
Selecting a Different Waveform for Inspection	9-16
The Channel Identifier	9-16
$\Delta T/\Delta V$ Button	9-17
The $\Delta T/\Delta V$ Marker and Numerics	9-17
Selecting New Origins	9-17
Measuring $\Delta T/\Delta V$ Values	9-17
Setting the $\Delta T/\Delta V$ Default	9-17

This chapter describes the front panel controls which allow you to select data for inspection and expand the displayed data for even closer inspections.

It also describes how you can quickly perform comparative measurements between any two data points on the selected waveform by assigning one data point as a new $t=0, v=0$ origin.

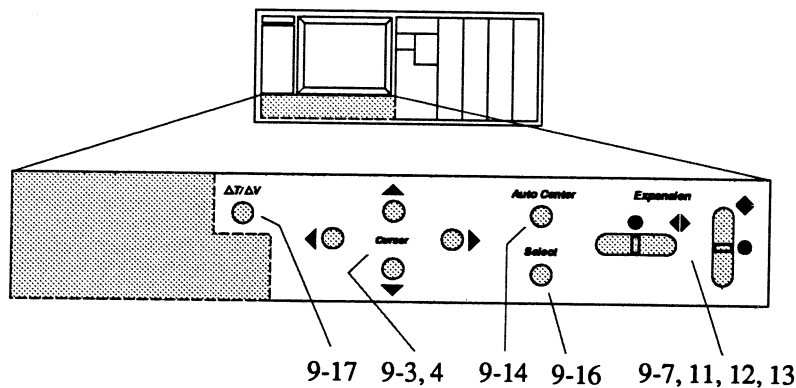

UP/DOWN CURSOR BUTTONS

The Up/Down Cursor Movement buttons are multifunctional.

Moving the Horizontal Cursor

The horizontal cursor moves vertically on the screen when either the Up or Down Cursor buttons are pressed (Figure 1).

Note: Autocenter turns off automatically when the Up or Down Cursor buttons are pressed.

Locating the Zero Volts Reference

Pressing both the Up and Down Cursor buttons simultaneously moves the horizontal cursor to the zero volts level on the screen (Figure 2).

Selecting the Next Peak

Pressing the Up Cursor button and either the Left or Right Cursor button simultaneously moves the crosshair to the next peak (Figure 3). See **Note 1** below.

Selecting the Next Valley

Pressing the Down Cursor button and either the Left or Right Cursor button simultaneously moves the crosshair to the next valley (Figure 4). See **Note 1** below.

Note 1: The instrument must be in the HOLD mode (Hold Last LED on, Live LED off). Next Peak/Next Valley is only accurate with continuously sloping waveforms (e.g., sine waves, triangle waves). If the data does not continue to slope through the function's window, it selects a local peak or valley value.

With Vertical Expansion Applied

Pressing the Up or Down Cursor button moves the waveform vertically on the screen (Figure 5). The horizontal cursor locks at screen center when Vertical Expansion is applied.

Note: Think of the waveform as stationary and the display screen as movable when expansion is turned on. The screen's "viewing window" will then appear to move in the same direction selected via the cursor buttons.

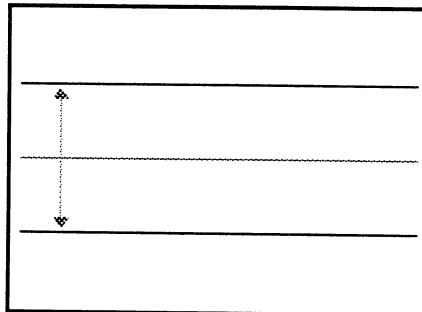

Figure 1 - Horizontal Cursor moves vertically when the Up or Down Cursor button is pressed.

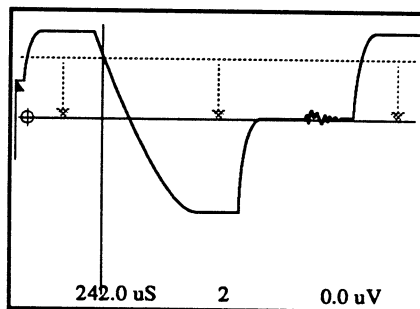

Figure 2 - The Horizontal Cursor moves to the zero volts level when the Up and Down Cursor buttons are pressed simultaneously.

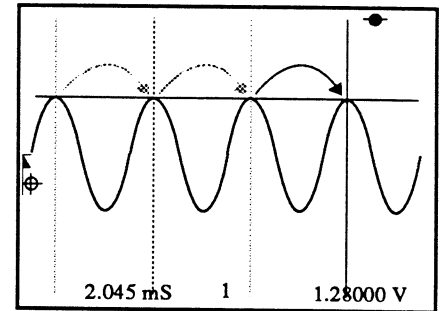

Figure 3 - The crosshair locates the next peak when the Right and Up Cursor buttons are pressed simultaneously.

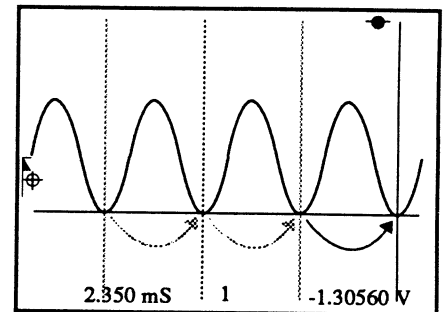

Figure 4 - The crosshair locates the next valley when the Right and Down Cursor buttons are pressed simultaneously.

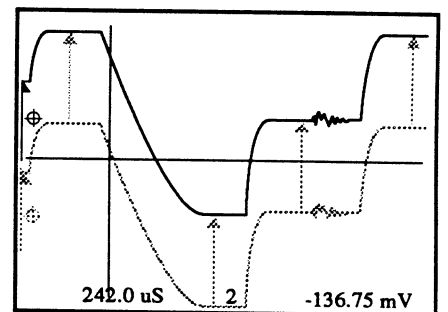

Figure 5 - The display screen "moves down" (the waveform appears to move up) when Vertical Expansion is turned on and the Down Cursor button is pressed.

LEFT/RIGHT CURSOR BUTTONS

The Left/Right Cursor Movement buttons are multifunctional.

Moving the Vertical Cursor

The vertical cursor moves across the screen when either the Left or Right Cursor buttons are pressed (Figure 1).

Locating Zero Time

Pressing both the Left and Right Cursor buttons simultaneously moves the vertical cursor to the trigger time ($t=0$) origin on the screen (Figure 2).

If in the Delayed Sweep mode, simultaneously pressing the Left and Right Cursor buttons will move the vertical cursor to the left edge of the screen.

Tracing the Waveform with the Crosshair

The crosshair traces the selected waveform if the Left or Right Cursor buttons are pressed when Autocenter is turned on and both Horizontal and Vertical Expansions are turned off (Figure 3). The left and right numerics simultaneously decode the data point values selected by the crosshair as it traces the waveform.

Horizontal Expansion and Autocenter On, Vertical Expansion Off

Pressing the Left or Right Cursor button moves the waveform horizontally on the screen. The vertical cursor locks at screen center and the horizontal cursor tracks each data point as it crosses the vertical cursor (Figure 4). The left and right numerics decode the values of each data point as it crosses the vertical cursor.

Horizontal & Vertical Expansions On, Autocenter On

The waveform passes through the crosshair locked at screen center when the Left or Right Cursor buttons are pressed when Horizontal and Vertical Expansions are turned on and Autocenter is turned on (Figure 5). This allows you to bring expanded portions of the waveform back into view for inspection. The numerics decode the values of each data point as they pass through the crosshair.

Note: Think of the waveform as being stationary and the display screen as being movable when expansion is turned on. The screen "viewing window" will then appear to move in the same direction selected via the cursor buttons.

Selecting the Next Peak

Pressing the Up Cursor button and either the Left or Right Cursor button simultaneously moves the crosshair to the next peak (Figure 6). See **Note 1** below.

Selecting the Next Valley

Pressing the Down Cursor button and either the Left or Right Cursor button simultaneously moves the crosshair to the next valley (Figure 7). See **Note 1** below.

Note 1: The Next Peak/Next Valley features are functional only while in the HOLD mode. In addition, it is only accurate with continuously sloping waveforms (e.g., sine waves, triangle waves). If the data does not continue to slope through the function's window, it selects a local peak or valley value.

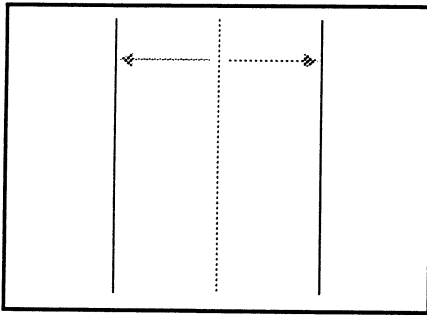

Figure 1 - The Vertical Cursor moves across the screen when the Left or Right Cursor button is pressed.

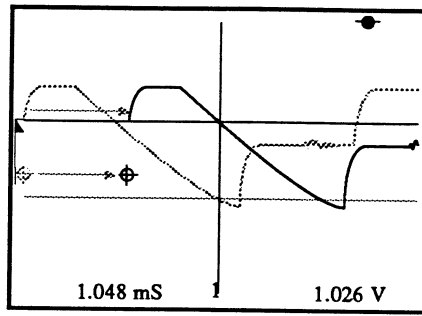

Figure 4 - The waveform moves across the screen when the Left or Right Cursor button is pressed. Horizontal Expansion and Autocenter must be turned on (Vertical Expansion must be off).

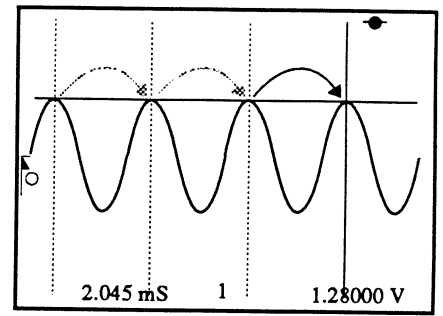

Figure 6 - The crosshair locates the next peak when the Right and Up Cursor buttons are pressed simultaneously.

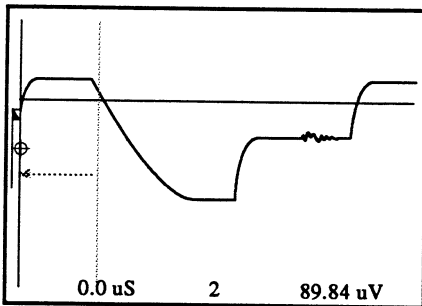

Figure 2 - The Horizontal Cursor moves to the trigger time ($t=0$) origin when the Left and Right Cursor buttons are pressed simultaneously.

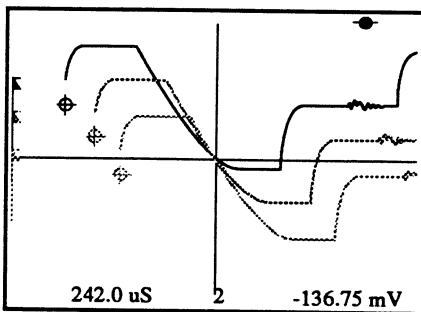

Figure 5 - The waveform passes through the crosshair locked at screen center when Horizontal Expansion, Vertical Expansion and Autocenter are all turned on and the Left or Right Cursor button is pressed.

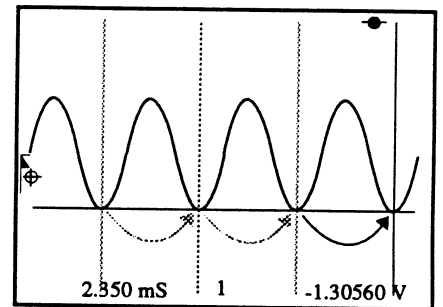

Figure 7 - The crosshair locates the next valley when the Right and Down Cursor buttons are pressed simultaneously.

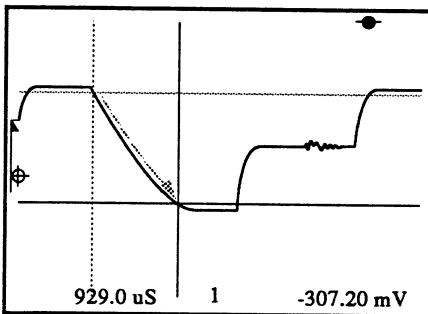

Figure 3 - The crosshair (formed by the two cursors) traces the waveform when the Left or Right Cursor button is pressed. Autocenter must be turned on and both Display Expansions must be turned off.

Wrapping-Around Cursors

When the cursor reaches the screen's horizontal limit (or vertical limit), it can be quickly moved to the opposite edge of the screen by releasing and then pressing the cursor button again.

Note: This also works for expanded waveform displays for moving the expanded waveform to the other edge of the screen.

EXAMPLE

Figure 1: The Left Cursor button was pressed and held until the vertical cursor stopped at the extreme left edge of the display screen.

Figure 2: After releasing the button and then pressing it again, the vertical cursor reappeared at the extreme right edge of the screen.

Selecting the Cursor Speed

The cursors can be stepped one data point (voltage level) at a time or moved in any one of several continuous speeds. If Autocenter is turned on, the crosshair will trace the selected waveform when the Left/Right Cursor buttons are pressed.

Note: This also works for expanded waveform displays to move the expanded waveform about the screen at faster rate of movements.

- **Stepping the Cursors**
Momentarily press the cursor buttons to move the vertical cursor one data point at a time (or horizontal cursor one voltage level at a time).

- **Continuous Cursor Movement**
Press and hold the cursor button to move the selected cursor at a slow rate of movement.

To increase the rate of movement to the next level:

1. Release the cursor button.
2. Immediately press and hold the cursor button again.

Repeat the above two steps to increase rate of movement to the next higher level.

- **Returning Cursors to the Slow Rate of Movement**
The slowest rate of movement returns after the cursor button is released for at least 1/2 second.

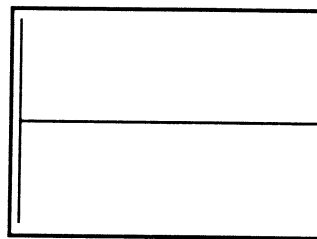

Figure 1 - The vertical cursor stopped at extreme left edge of the screen while the Left Cursor button was being pressed.

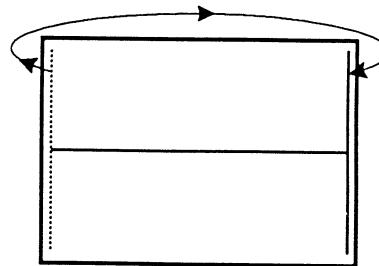

Figure 2 - The vertical cursor reappeared at the right edge of the screen after releasing and then pressing the Left Cursor button.

INTRODUCTION TO DISPLAY EXPANSION

Display expansion is used to enhance your ability to see small deviations on the signal. The actual display expansion buttons are described later in this chapter. This section of the chapter will help you to become familiar with the basics of display expansion.

Note: Figure 1 identifies various screen elements used during the display expansion discussions on the following pages.

Horizontal Expansion

Use horizontal expansion to enlarge features along the x-axis for closer inspections. Move the vertical cursor over the data point you wish to be the center of interest when horizontal expansion is applied.

See Figures 2 and 3 on the next page.

Vertical Expansion

Use vertical expansion to enlarge features along the y-axis for closer inspection. Move the horizontal cursor over the data point(s) you wish to be the center of interest when vertical expansion is applied.

See Figures 4 and 5 on the next page.

Horizontal & Vertical Expansion

Combine horizontal and vertical expansion to enlarge small features along both axes.

See Figures 6 and 7 on the next page.

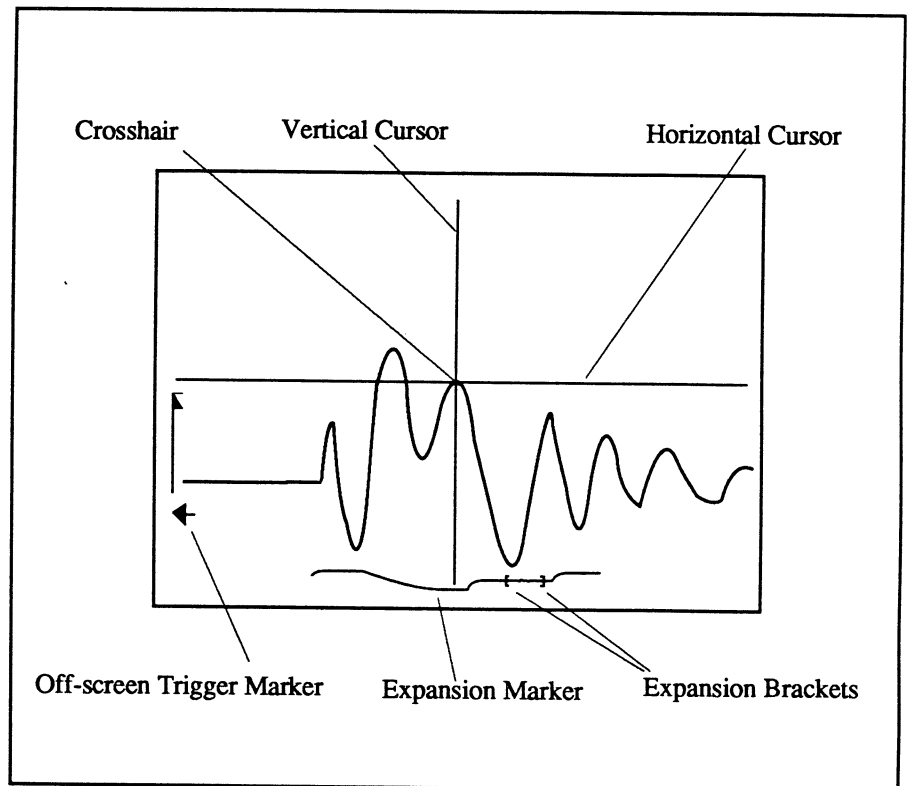

Figure 1 - Review of screen elements used during this discussion.

Setting the Expansion Defaults

You can set a default for pre-selected display expansion factors each time power is applied to the instrument.

This feature is handy when you are consistently capturing signals with very small deviations, thus allowing you to easily observe the captured data without having to adjust the display expansion factors each time you power up the instrument.

1. Select the desired amount of horizontal expansion and then press and hold the center of the Horizontal Expansion button. The waveform will disappear momentarily; when it reappears, release the button.
2. Select the desired amount of vertical expansion and then press and hold the center of the Vertical Expansion button. The waveform will disappear momentarily; when it reappears, release the button.

The instrument will now default to the expansion factors you have selected each time power is applied to the instrument.

Horizontal Expansion Only

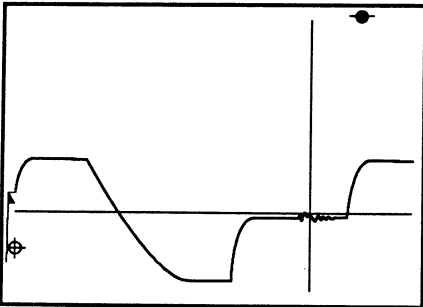

Figure 2 - Autocenter was turned on and the crosshair was positioned over the area of interest on the unexpanded waveform.

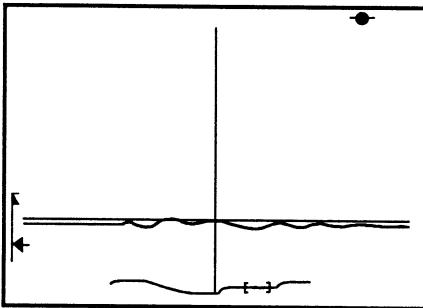

Figure 3 - The right side of the Horizontal Expansion button was pressed several times. This caused the vertical cursor and the area of interest to move to screen horizontal center while the area of interest expanded about the vertical cursor.

The expansion indicator at the bottom of the screen shows you which portion of the waveform is being viewed. The distance between the two brackets decreases as horizontal expansion is increased.

The Data Trigger Marker ⊕ in Figure 2 was replaced by the small arrow at the left edge of the screen because the trigger point (t=0) was forced off the left edge of the screen. The vertical location of the arrow still locates the zero volts level.

Vertical Expansion Only

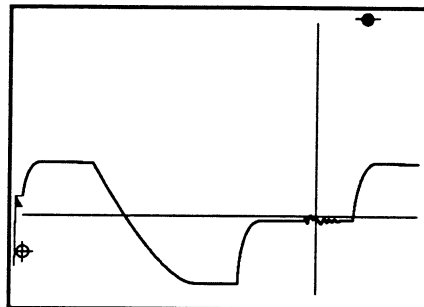

Figure 4 - Autocenter was turned on and the crosshair was positioned over the area of interest on the unexpanded waveform.

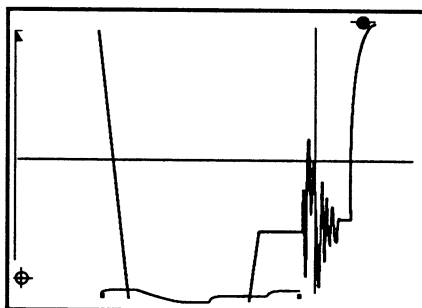

Figure 5 - The top of the Vertical Expansion button was pressed several times. This caused the horizontal cursor and area of interest to move to screen vertical center while the area of interest expanded about the horizontal cursor.

The expansion indicator at the bottom of the screen now shows you which portion of the waveform is being viewed. The height of the two brackets decrease as vertical expansion is increased.

The Data Trigger Marker ⊕ remains displayed on the screen because the trigger point (t=0) is still located at the left edge of the screen.

Horizontal & Vertical Expansion Combined

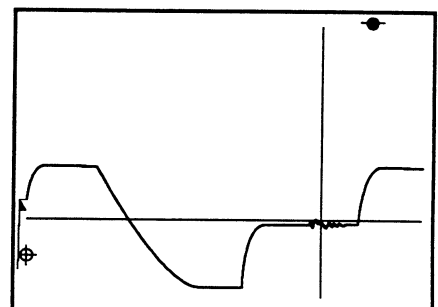

Figure 6 - Autocenter was turned on and the crosshair was positioned over the area of interest on the unexpanded waveform.

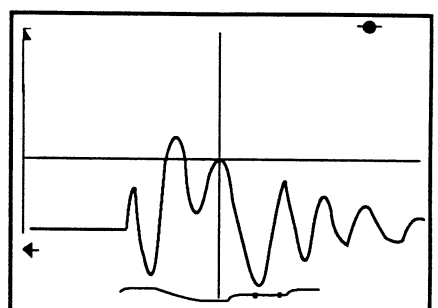

Figure 7 - Both Horizontal and Vertical Expansion were applied. This caused the crosshair (formed by the two cursors) and the area of interest surrounding the crosshair to move to screen center.

The expansion indicator at the bottom of the screen now shows which portion of the expanded waveform is being viewed.

Since Horizontal Expansion forced the Data Trigger Marker ⊕ off the left edge of the screen, the marker was replaced by the small arrow at the left edge of the screen. The vertical location of the arrow continues to locate the zero volts level.

More about the Expansion Marker

The Expansion Marker is composed of a sweep line and two brackets. The marker appears at the bottom of the screen when expansion is applied.

- **The Sweep Line**

The sweep line represents one full sweep (Figure 1). After capturing a signal, the sweep line will change to a representation of the captured waveform as illustrated in Figure 3.

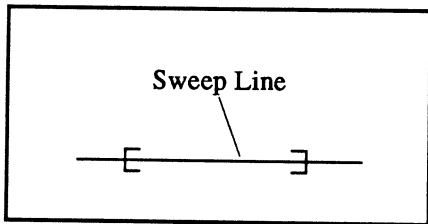

Figure 1

- **The Expansion Brackets**

The width of the Expansion Brackets identifies which portion of the waveform is being viewed on the screen. The width of the window decreases as horizontal expansion is increased (Figure 4).

The height of the Display Window represents the amount of Vertical Expansion. The height of the brackets decrease as Vertical Expansion is increased (Figure 5).

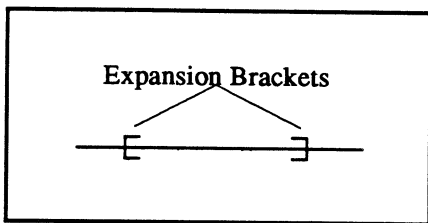

Figure 2

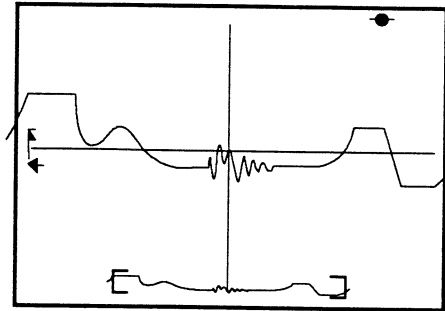

Figure 3 - A very small amount of Horizontal Expansion was applied. The two Expansion Brackets enclose the portion of the waveform that is being viewed.

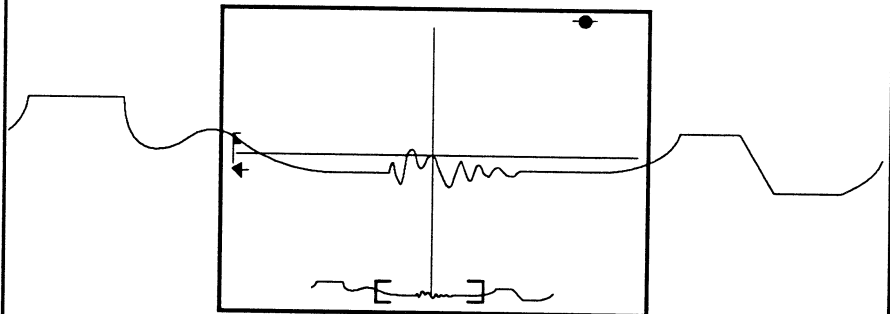

Figure 4 - Horizontal Expansion was increased. This forced more of the waveform off screen to provide room for the newly expanded area of interest. Note that the Expansion Brackets are now closer together, corresponding to the portion of the waveform being viewed.

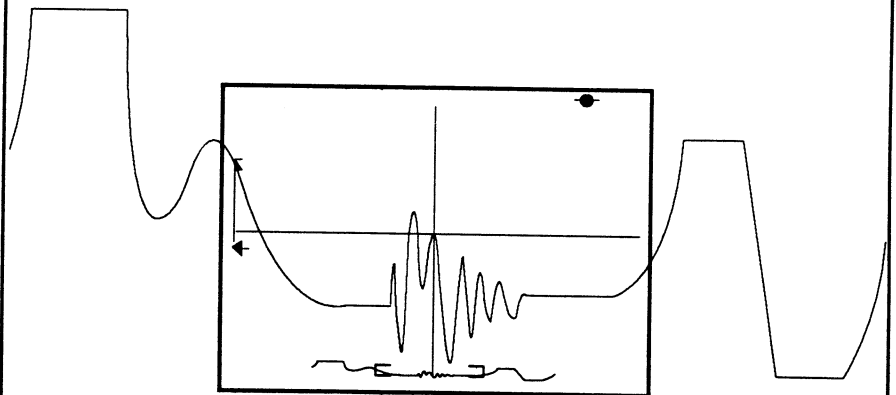

Figure 5 - Vertical Expansion was added next. The distance between the two brackets remained unchanged, but the height of the two brackets has decreased to indicate that vertical expansion has been increased.

Inspecting Expanded Waveforms

Figures 6 through 8 illustrate the effects of pressing the Right Cursor button when Vertical and Horizontal Expansion are applied and Autocenter is turned on.

Think of the expanded waveform as stationary and the display screen as a movable "viewing window" when display expansions are applied and Autocenter is turned on. Then, when you wish to move the "viewing window" to the right, simply press the Right Cursor button.

Likewise, pressing the Left Cursor button will move the "viewing window" to the left.

Note: Pressing the Up or Down Cursor buttons automatically turns off the Autocenter mode. This will cause the "viewing window" to move vertically when the Up or Down Cursor buttons are pressed.

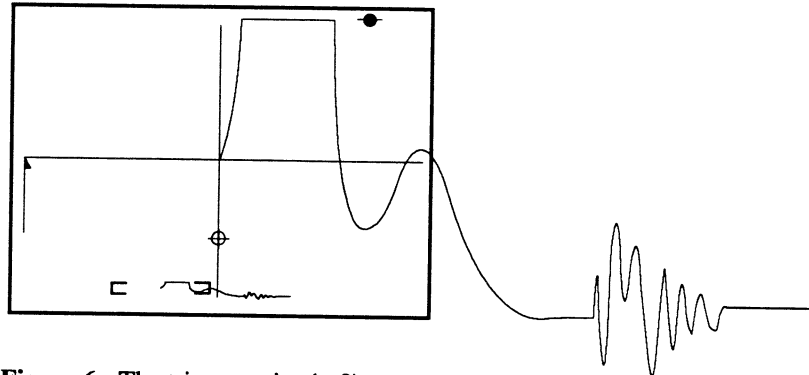

Figure 6 - The trigger point ($t=0$) was selected as the point of interest and then Vertical and Horizontal Expansion was applied.

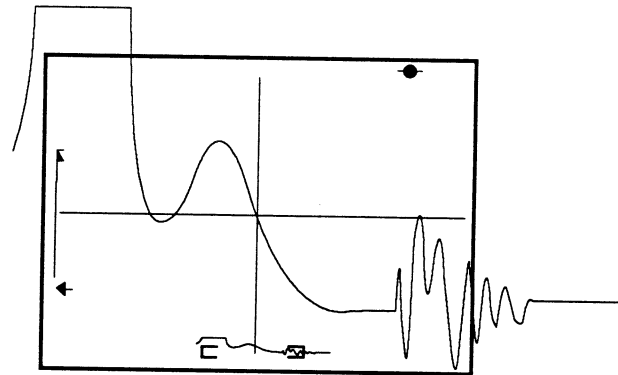

Figure 7 - The Right Cursor button was pressed. This caused the screen "viewing window" to slide to the right while the waveform passed through the crosshair locked at screen center.

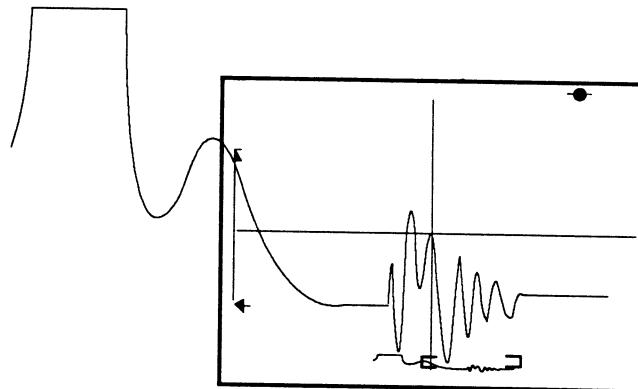

Figure 8 - The "viewing window" continues to slide to the right and the waveform continues to pass through the crosshair while the Right Cursor button is pressed.

HORIZONTAL EXPANSION BUTTON

The Horizontal Expansion button (Figure 1) allows you to symmetrically expand an area of interest about the vertical cursor for closer inspections. It also allows you to set a horizontal expansion default setting and then quickly recall it later (see page 9-13).

Note: Expansion affects the Cursor button functions (see page 9-5). Also, see page 9-7, Expansion Defaults.

Horizontal Expansion Factors

The number of data points that can be used to display an expanded area of interest is determined automatically by the instrument. The instrument selects the nearest value from Table 1 which is less than the Sweep Length (see Chapter 18) to determine the starting point.

For example, if the waveform was captured using a Sweep Length of 8k (Figure 2), then the first expansion factor will use 5k data points because this is the first value less than 8k.

Figure 3 illustrates that now only 5k data points are visible on the screen, rather than the full 8k Sweep Length. Thus, the distance between each data point has increased which, in turn, expands the area of interest.

Figure 4 shows that the Horizontal Expansion button was pressed again. Now only 2k data points are visible, further increasing the distance between each data point.

Horizontal Expansion can continue to be applied until the minimum number of data points of 50 (from Table 1) is reached.

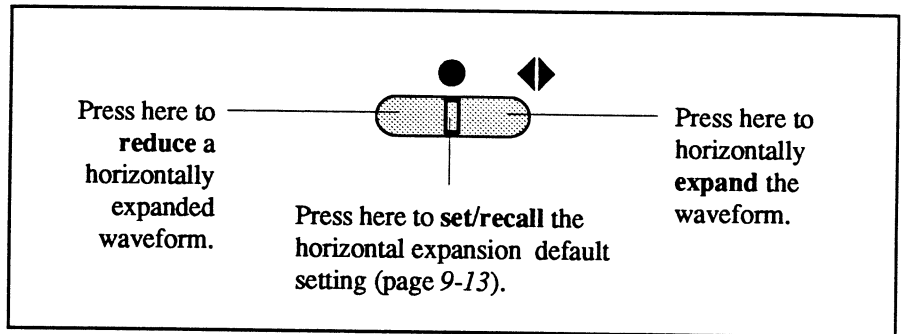
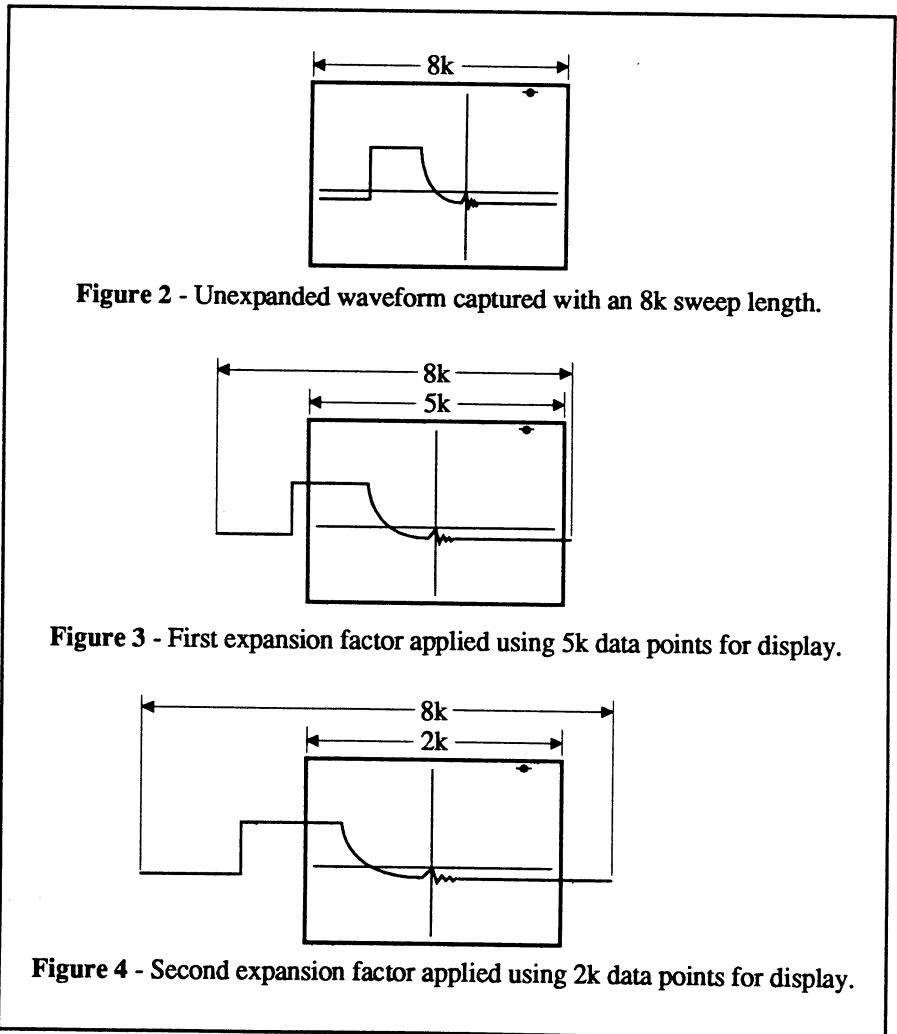

Figure 1 - Horizontal Expansion Button

Expansion increases as # decreases →

200k, 100k, 50k, 20k, 10k, 5k, 2k, 1k, 500, 200, 100, 50
--

Table 1 - Number of data points available to horizontally expand a waveform.



VERTICAL EXPANSION BUTTON

The Vertical Expansion button symmetrically expands the displayed waveform about the horizontal cursor for closer inspection of voltage details on the waveform.

Note: Expansion affects the Cursor button functions (see page 9-5). Also, see page 9-7, Expansion Defaults.

The Vertical Expansion button allows you to vertically expand the waveform display or set a specific vertical expansion default setting and then quickly recall it later (see page 9-13).

Vertical Expansion Factors

Table 1 shows the vertical expansion factors that will be used to expand the selected area of interest for closer inspection.

Note: Unlike the horizontal expansion feature, vertical expansion factors are not dependent upon the sweep length.

The first time you press the top of the Vertical Expansion button, the selected area of interest expands vertically by a factor of x1.5.

As you continue to press the Vertical Expansion button, the area of interest continues to expand by the factors listed in Table 1. The maximum allowable vertical expansion is x512.

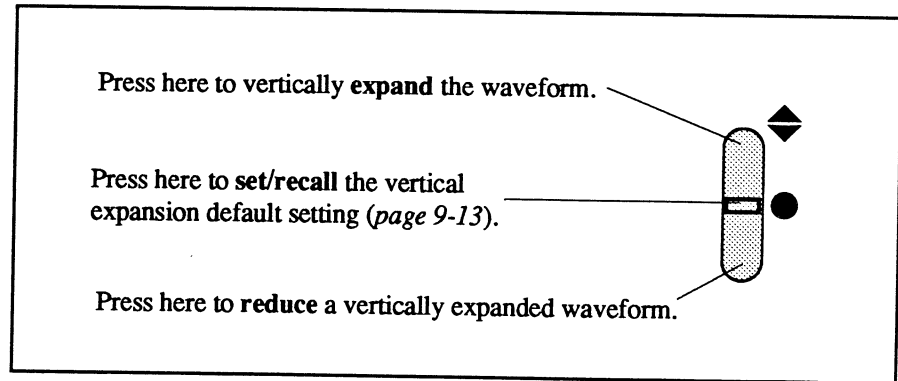

Figure 1 - Vertical Expansion Button

<p>Max. Expansion </p> <p>1.5, 2, 3, 6, 10, 16, 24, 32, 64, 128, 256, 512</p>

Table 1 - Expansion factors (beginning with x1.5) used to vertically expand the area of interest each time you press the top of the Vertical Expansion button.

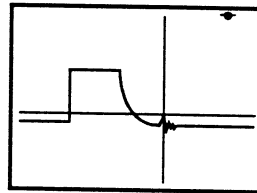

Figure 2 - An unexpanded waveform display.

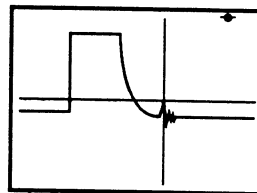

Figure 3 - The first expansion factor of x1.5 was applied.

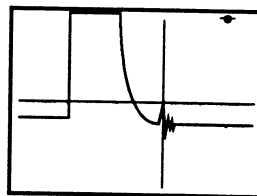

Figure 4 - The second expansion factor of x2 was applied.

SETTING EXPANSION DEFAULTS

The center of each Expansion button allows you to set a default expansion setting and then quickly recall it at any time.

Note: The expansion default settings remain in memory even when power is removed from the instrument.

1. Capture the data (Figure 1).
2. Select the desired amount of horizontal expansion (Figure 2).
3. Press and hold the center of the Horizontal Expansion button. This will cause the previous default setting to reappear (Figure 3).
4. Release the Horizontal Expansion button when the new default setting reappears (Figure 4).
5. Select the desired amount of vertical expansion (Figure 6).
6. Press and hold the center of the Vertical Expansion button. This will cause the previous vertical expansion default setting to reappear (Figure 7).
7. Release the Vertical Expansion button when the new default setting reappears (Figure 8).

You now can experiment with different expansion settings and then quickly return to the defaults by momentarily pressing the center of the Expansion buttons.

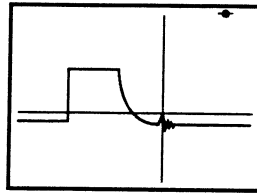

Figure 1 - Unexpanded display. Assume that both the Horizontal and Vertical Expansion buttons are currently set to default to "unexpanded display".

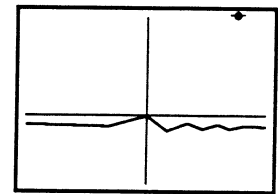

Figure 5 - The horizontally expanded waveform repeated here from Figure 4.

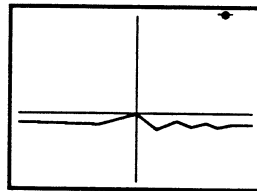

Figure 2 - The desired amount of horizontal expansion was applied.

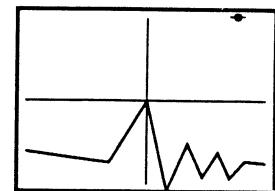

Figure 6 - The desired amount of vertical expansion was applied.

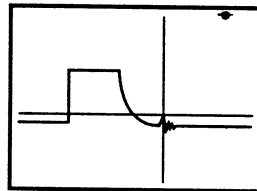

Figure 3 - The original display in Figure 1 reappears when the center of the Horizontal Expansion button is pressed and held.

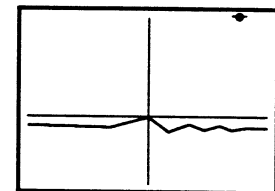

Figure 7 - The expanded display in Figure 5 reappears when the center of the Vertical Expansion button is pressed and held.

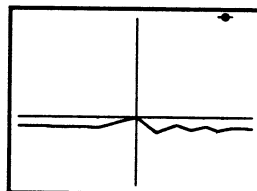

Figure 4 - When the expanded waveform reappears, you can release the Horizontal Expansion button. This is now the new horizontal expansion default setting.

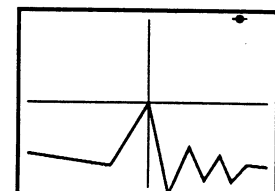

Figure 8 - When the vertically expanded waveform reappears, you can release the Vertical Expansion button. This is now the new vertical expansion default setting.

AUTOCENTER BUTTON

Press the Autocenter button to turn Autocenter on or off. The Autocenter On Indicator (Figure 1) appears at the top of the screen when Autocenter is turned on.

Autocenter affects how the Cursor buttons operate (see *pages 9-3 and 9-4*). The three most commonly used methods of inspecting captured data are described below.

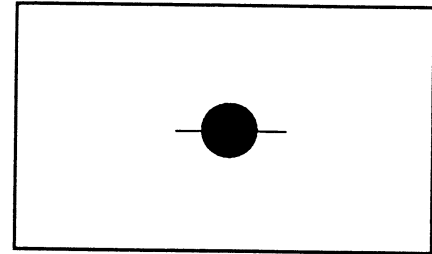

Figure 1 - Autocenter On Indicator

Autocenter OFF, Expansions OFF

Autocenter: OFF
Horizontal Expansion: OFF
Vertical Expansion: OFF

See Figures 2, 3 and 4 on the next page.

The cursors move about the screen independently of each other when any of the four Cursor buttons are pressed.

This mode is useful for:

- Preventing the cursors from jumping about the screen as new signals are being captured.
- Selecting new baselines or start/stop points when employing some of the downloadable Programs described in *Chapter 15*.
- Selecting a new time origin without changing the voltage origin (and vice-versa) when employing the $\Delta T, \Delta V$ feature. (See $\Delta T, \Delta V$ later in this chapter.)

Autocenter ON, Expansions OFF

Autocenter: ON
Horizontal Expansion: OFF
Vertical Expansion: OFF

See Figures 5, 6 and 7 on the next page.

The crosshair formed by the Horizontal and Vertical Cursors traces the displayed waveform when the Left or Right Cursor buttons are pressed.

Note: Pressing the Up/Down cursor buttons automatically turns Autocenter off.

This mode is useful for:

- Multiple waveforms displays.
- Single button operation for simultaneous time and voltage measurements of individual data points by pressing either the Left or Right Cursor buttons.
- Single button operation when selecting a data point as the new time and voltage origins by pressing the Left or Right Cursor buttons. (See $\Delta T, \Delta V$ later in this chapter).
- Inspecting XY displays.

Autocenter ON, Expansions ON

Autocenter: ON
Horizontal Expansion: ON
Vertical Expansion: ON

See Figures 8, 9 and 10 on the next page.

The waveform passes through the crosshair locked at screen center when the Left/Right Cursor buttons are pressed.

Note: Pressing the Up/Down cursor buttons automatically turns Autocenter off.

This mode is useful for:

- Maintaining the expanded area of interest at screen center.
- Concentrating the your focal point at screen center as different portions of the expanded waveform are brought into view for inspection by pressing the Left or Right Cursor buttons.
- Inspecting XY displays.

Note: When using this mode, think of the display screen as being moveable while the waveform remains stationary. To inspect data to the right of the crosshair, press the Right Cursor button. Likewise, press the Left Cursor button to view data to the left of the crosshair.

Moving the Cursors Independently of Each Other

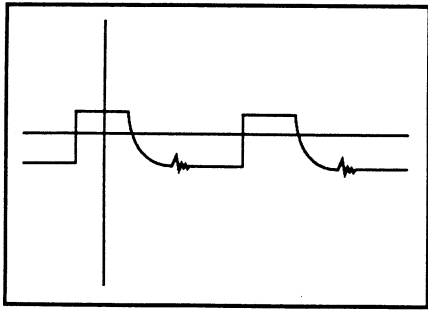

Figure 2 - Autocenter, Horizontal and Vertical Expansion turned off.

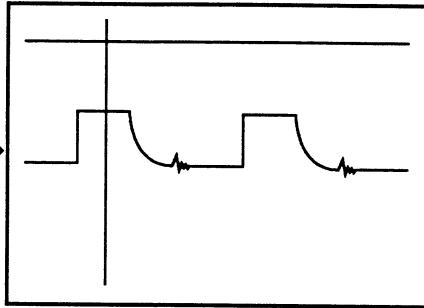

Figure 3 - The horizontal Cursor moves up when the Up Cursor button is pressed.

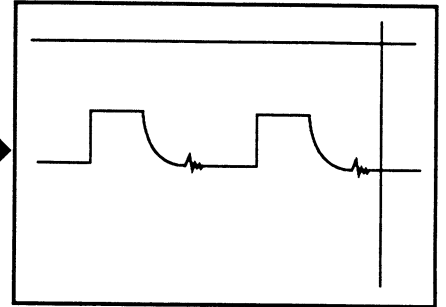

Figure 4 - The Vertical Cursor moves right when the Right Cursor button is pressed.

Tracing the Waveform with the Crosshair

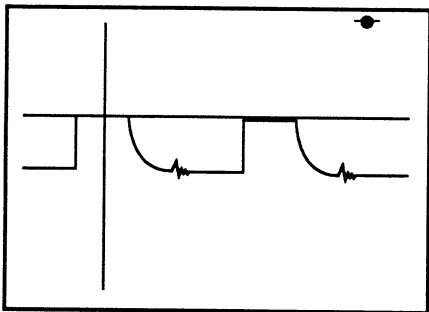

Figure 5 - Autocenter turned on; Horizontal and Vertical Expansion turned off.

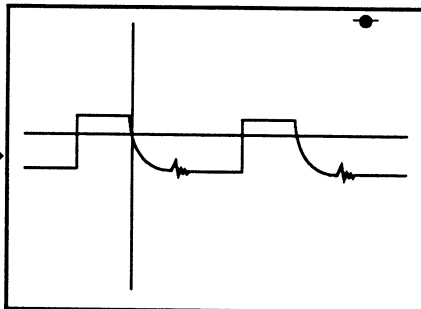

Figure 6 - The crosshair moves right as it traces the waveform when the Right Cursor button is pressed.

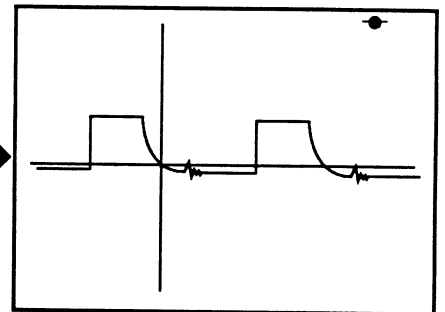

Figure 7 - The crosshair continues to trace the waveform as the Right Cursor button is pressed.

Moving the Waveform Through the Crosshair Locked at Screen Center

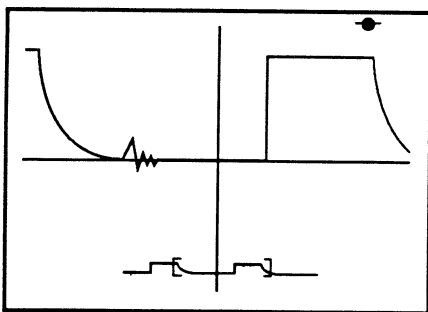

Figure 8 - Autocenter, Horizontal and Vertical Expansion all turned on.

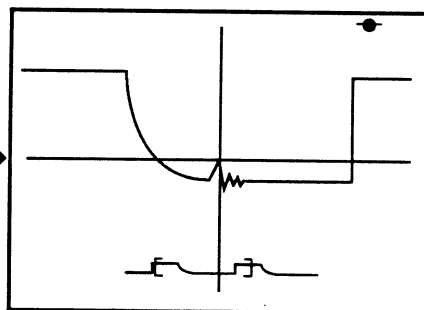

Figure 9 - The waveform moves right as it passes through the crosshair locked at screen center when the Left Cursor button is pressed.

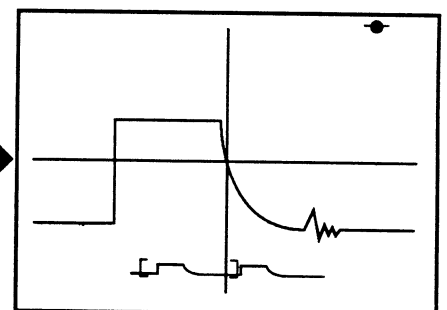

Figure 10 - The waveform continues passing through the crosshair as the Left Cursor button is pressed.

SELECT BUTTON

Press the Select button when multiple waveforms are being displayed to select which waveform will be decoded by the numerics.

Selecting a different waveform for inspection

The waveform you have selected for inspection will be displayed brighter on the screen (Figure 1).

To select a different waveform for inspection, press the Select button until the desired waveform is highlighted (Figure 2).

Note: If Autocenter is turned on, the crosshair will also position over the selected waveform (Figure 3).

The Channel Identifier

The channel identifier is located at the bottom center of the display screen (Figures 1, 2 and 3). It is used to identify which channel captured the selected waveform and whether or not the selected waveform is a "saved" waveform.

- 1 = Captured by channel 1
- 1S = Channel 1 saved waveform

- 2 = Captured by channel 2
- 2S = Channel 2 saved waveform

- 3 = Captured by channel 3
- 3S = Channel 3 saved waveform

- 4 = Captured by channel 4
- 4S = Channel 4 saved waveform

- E = External (Trigger View only)

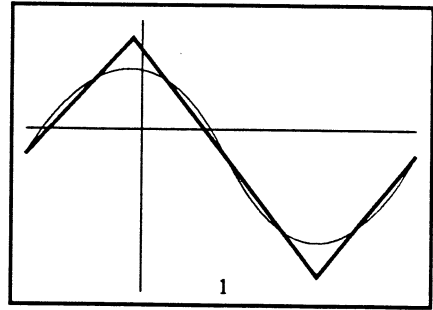

Figure 1 - The triangle wave stored in channel 1 was selected for inspection. Therefore, the triangle wave is brighter on the screen and a "1" is displayed at the bottom center of the screen.

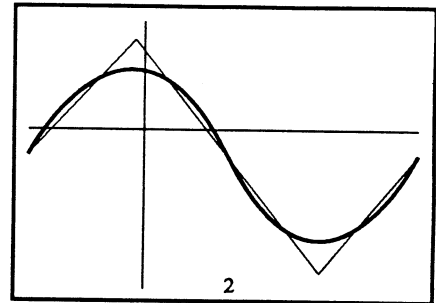

Figure 2 - The Select button was pressed, thus selecting the sine wave stored in channel 2. The sine wave is now brighter and a "2" is displayed at the lower center of the screen.

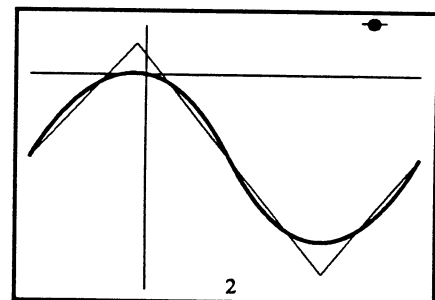

Figure 3 - Turning Autocenter on further defines that the sine wave has been selected for inspection because the crosshair is now positioned over the sine wave. Note the Autocenter marker in the upper right corner appears when Autocenter is on.

$\Delta T/\Delta V$ BUTTON

The $\Delta T/\Delta V$ button allows you to select new origins for comparative measurements between any two features of the selected waveform.

Note: Also see the example on the following page.

The $\Delta T/\Delta V$ Marker

The $\Delta T/\Delta V$ Marker (Figure 1) shows where the new origin was located when the $\Delta T/\Delta V$ button was pressed.

The $\Delta T/\Delta V$ Numerics

A second set of numerics are displayed on the screen when the $\Delta T/\Delta V$ feature is being employed (Figure 1). The numerics decode values measured with respect to the new origin.

Note: The "normal" lower numerics continue to decode values measured with respect to the original $t=0, v=0$ coordinates when in the YT mode, and x-axis, y-axis voltage values measured with respect to the original zero volts references when in the XY display mode.

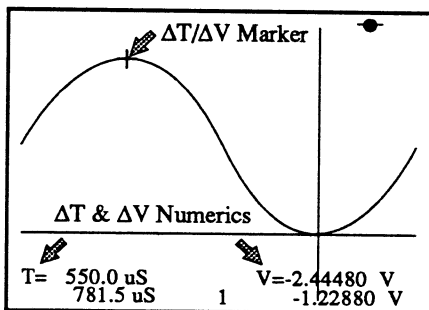

Figure 1 - The $\Delta T/\Delta V$ Marker, Time Numerics and Voltage Numerics.

Selecting New Origins

The new origins will be set at the intersection of the horizontal and vertical cursors (the crosshair) when the $\Delta T/\Delta V$ button is pressed.

Autocenter should be turned on when selecting a data point on a waveform; adding display expansion is useful when isolating a specific data point (such as the peak-most data point on a waveform).

1. Position the crosshair over the data point that is to become the new $\Delta T=0, \Delta V=0$ origins using the Left or Right Cursor buttons.
2. Press the $\Delta T/\Delta V$ button. The $\Delta T/\Delta V$ marker identifies the position of the new origin and the $\Delta T/\Delta V$ numerics are set to $\Delta T=0, \Delta V=0$.

Measuring $\Delta T/\Delta V$ Values

Once the new origin has been set, comparative measurements can be read directly from the ΔT and ΔV numerics as the cursors are moved about the screen. The $\Delta T/\Delta V$ marker remains stationary as measurements are performed.

Setting the $\Delta T/\Delta V$ Default

Pressing and holding the $\Delta T/\Delta V$ button for approximately 2 seconds will set the $\Delta T/\Delta V$ Marker to default at its current position. You can then reposition the $\Delta T/\Delta V$ Marker to new locations on the screen for measurements and then quickly return to the default setting by pressing and holding the $\Delta T/\Delta V$ button. Release the $\Delta T/\Delta V$ button as soon as the marker moves to its default setting. If you continue to hold in the $\Delta T/\Delta V$ button, the marker will return to the crosshair location and this will become the new default.

Exiting $\Delta T/\Delta V$

Press the $\Delta T/\Delta V$ button again to exit the $\Delta T/\Delta V$ mode. The $\Delta T/\Delta V$ marker and Δ -numerics will disappear from the screen.

Example

Figures 1 through 4 illustrate the steps taken to measure the peak-to-peak voltage and time differences between two peaks of a sine wave.

Note: You can move the crosshair over a peak or valley by turning on Autocenter and pressing the Left/Right Cursor buttons. You can also select a peak/valley with the Next Peak/Next Valley features by simultaneously pressing the Up/Right, Up/Left, Down/Right or Down/Left cursor buttons. These features are further described on pages 9-3 and 9-4 in this chapter.

Figure 1 - The peak-to-peak voltage and time interval between the peak and valley on this sine wave are to be measured. The crosshair in this figure was positioned over the peak.

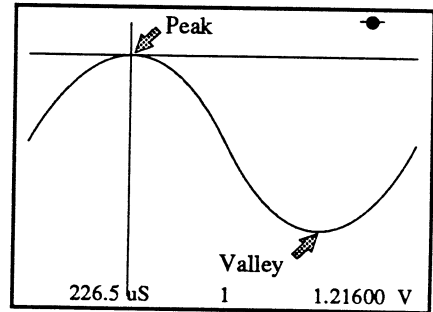

Figure 1

Figure 2 - The waveform was then expanded to confirm that the peak-most data point was located. The crosshair in this example was off by two data points from the peak-most data point.

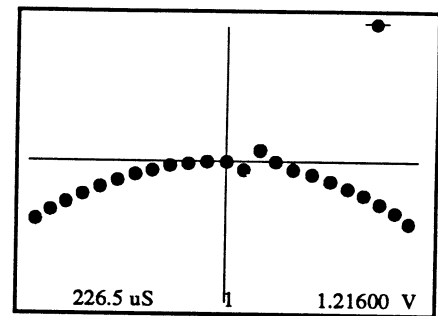

Figure 2

Figure 3 - The Right Cursor button was pressed twice to move the peak-most data point to the crosshair and then the $\Delta T/\Delta V$ button was pressed. This caused the Δ -Marker and Δ -Numerics to appear on the screen. Note that the Δ -Numerics are currently set to 0.

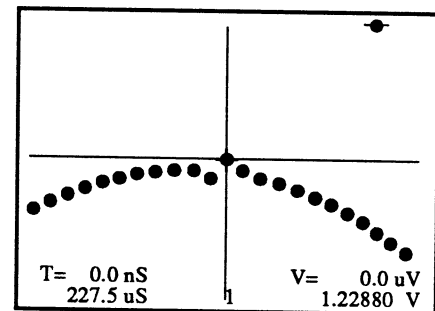

Figure 3

Figure 4 - Expansion was turned off and the crosshair was positioned over the valley. The valley-most data point was located in the same manner as in Figures 2 and 3. The final display at the right (with expansion turned off) now allows you to read the peak-to-valley time and voltage as well as the time and voltage values measured with respect to the original $t=0, v=0$ origins.

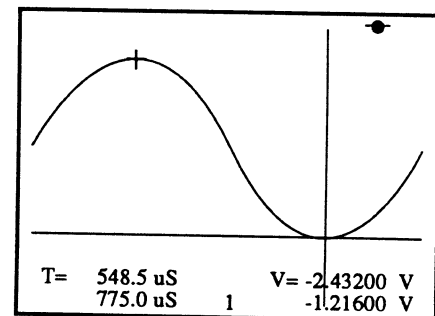

Figure 4

Chapter 10

THE TIME

CONTROL

Sampling the Signal	10-3
Varying the Time Per Point	10-4
Varying the Sweep Length	10-5
Setting the Sweep Length	10-8
Selecting the Time	10-9
Calculating the Sweep Time	10-9
External Clock	10-10

This section describes the Time control which, along with the Sweep Length function's value, determines which samples from the analog input signal will be digitized for display on the screen.

An external clock signal can also be used to determine which samples will be selected for display.

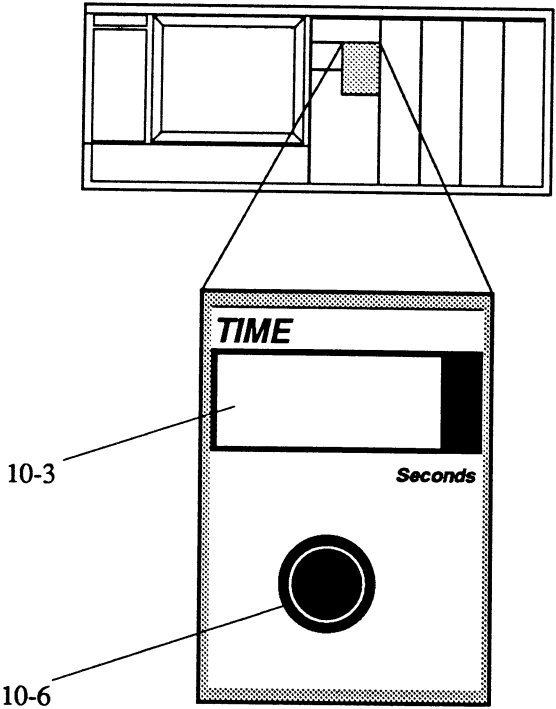

SAMPLING THE SIGNAL

The digitizers sample the analog input signal at a constant sampling rate (Table 1).

Which of the digitized samples are selected for display is dependent upon the value entered on the SECONDS readout and the SWEEP LENGTH value entered via the Sweep Length Menu (*Chapter 17*). These are discussed on the following pages.

Figures 1 and 2 - Each of the white dots represent when the analog input signal was sampled using two different digitizers. Since the 10 MS/s digitizer is ten times faster than the 1 MS/s digitizer, the analog input signal in Figure 1 is sampled ten times more within the same time window than in Figure 2. For example, the input signal is sample once in Figure 2 for every ten samples in Figure 1 during identical time windows (2 μ S = 2000 nS).

Note: The remaining examples will use the 10 MS/s, 12 bit digitizers.

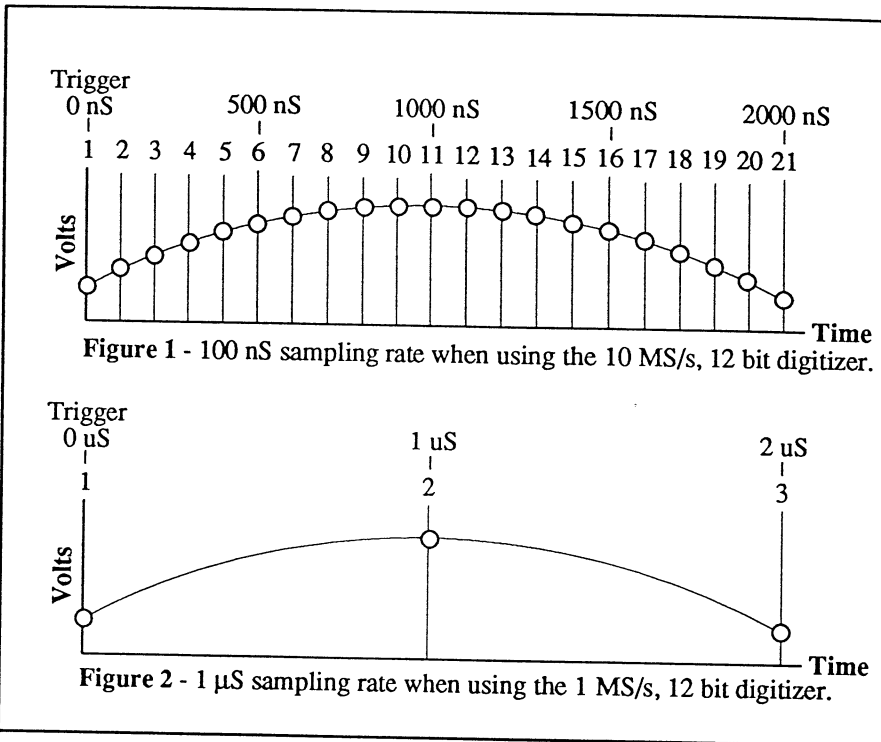

MODEL	DIGITIZERS INSTALLED	SAMPLING RATES
Pro 10	Two 1 MS/s, 12 bit	1 μ s
Pro 20	Four 1 MS/s, 12 bit	1 μ s
Pro 30	Two 10 MS/s, 12 bit	100 ns
Pro 32	Two 20 MS/s, 12 bit	50 ns
Pro 34	Four 20 MS/s, 12 bit	50 ns
Pro 40	Four 10 MS/s, 12 bit	100 ns
Pro 42	Two 5 MS/s, 14 bit	200 ns
Pro 44	Four 5 MS/s, 14 bit	200 ns
Pro 50	Two 200 MS/s, 8 bit	5 ns
Pro 60	Four 200 MS/s, 8 bit	5 ns
Pro 90 (see Note 1)	Two 10 MS/s, 12 bit Two 200 MS/s, 8 bit	100 ns 5 ns
Pro 92 (see Note 1)	Two 20 MS/s, 12 bit Two 200 MS/s, 8 bit	50 ns 5 ns

Table 1 - Sampling Rates

Note 1: The Pro 90 Model (Pro 92 Model) is configured with two digitizers of one type and two of another, thus allowing the instrument to simultaneously capture signals with dual sampling rates. For example, a Pro 90 can be configured with two 10 MS/s, 12 bit digitizers and two 200 MS/s, 8 bit digitizers (see *Chapter 27* for additional information).

VARYING THE TIME PER POINT

Assume the input signal is being sampled once every 100 nS as shown in Figure 1. The following examples illustrate the effect of increasing the Time Per Point setting while the Sweep Length value remains fixed at 1000 data points.

Note: Due to space limitations, only the first 21 of the total 1000 data points on the screen will be discussed.

Figures 2 through 4 show you how longer records of the input signal are captured by increasing the Time Per Point setting.

When the Time Per Point is equal to the sampling rate as in Figure 2, it will take 2000 nS to digitize all 21 samples. Thus, you will have a record length of 2000 nS.

Figure 3 shows that alternate samples are digitized for display when the Time Per Point setting is twice the sampling rate. Since it now takes 4000 nS to define the first 21 data points, the record length is twice as long as the 2000 nS record in Figure 2. Assuming that the signal is repetitive, you will have captured a second cycle of the input signal (grayed portion in Figure 3) for display by the time the 21st data point is defined.

Figure 4 shows that every fifth sample is digitized when the Time Per Point setting is five times the sampling rate. It now takes 10,000 nS before all 21 data points are defined, resulting in a record length five times longer than the 2000 nS record length in Figure 2. Again, assuming that the signal is repetitive, you will have captured four additional cycles (grayed portion in Figure 4) for display by the time the 21st data point is defined.

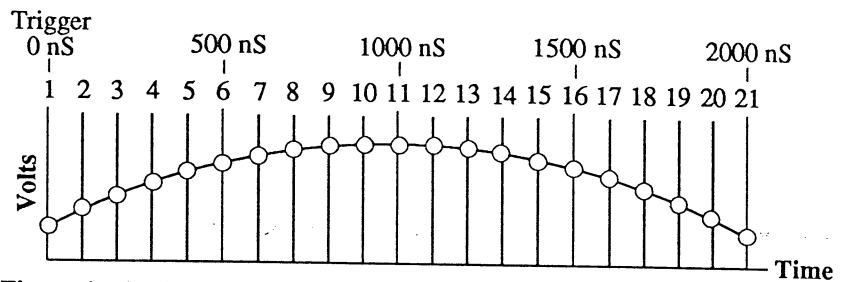

Figure 1 - Analog input signal superimposed with the 100 nS sampling rate. The Time Per Point setting will determine which samples are digitized.

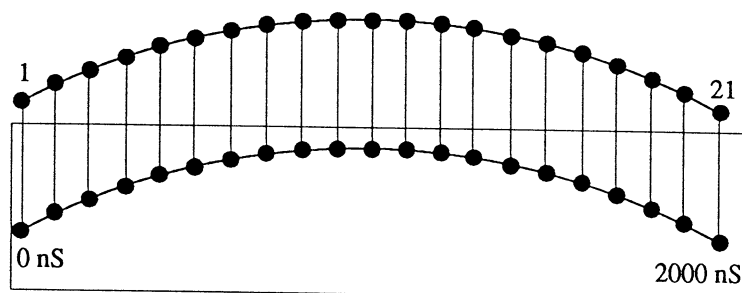

Figure 2 - Each of the 21 samples are displayed by the first 21 data points when Time Per Point = 100 nS and Sweep Length = 1000.

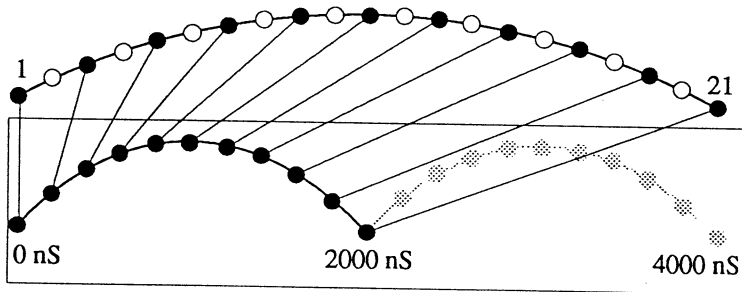

Figure 3 - Alternate samples (black dots) are digitized when Time Per Point = 200 nS and Sweep Length = 1000. Undigitized samples (white dots) are discarded.

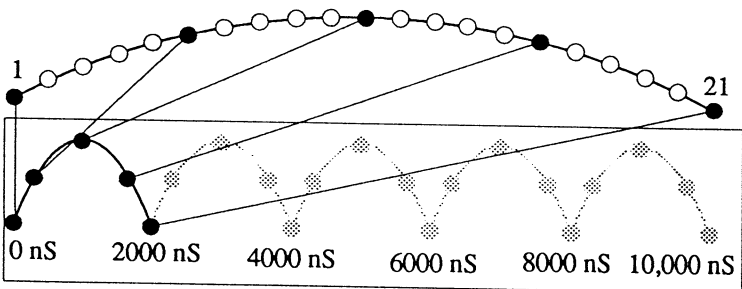

Figure 4 - Every fifth sample (black dots) is digitized when Time Per Point = 500 nS and Sweep Length = 1000. The undigitized samples (white dots) are discarded.

SAMPLING THE SIGNAL

The digitizers sample the analog input signal at a constant sampling rate (Table 1).

Which of the digitized samples are selected for display is dependent upon the value entered on the SECONDS readout and the SWEEP LENGTH value entered via the Sweep Length Menu (Chapter 17). These are discussed on the following pages.

Figures 1 and 2 - Each of the white dots represent when the analog input signal was sampled using two different digitizers. Since the 10 MS/s digitizer is ten times faster than the 1 MS/s digitizer, the analog input signal in Figure 1 is sampled ten times more within the same time window than in Figure 2. For example, the input signal is sample once in Figure 2 for every ten samples in Figure 1 during identical time windows (2 μ S = 2000 nS).

Note: The remaining examples will use the 10 MS/s, 12 bit digitizers.

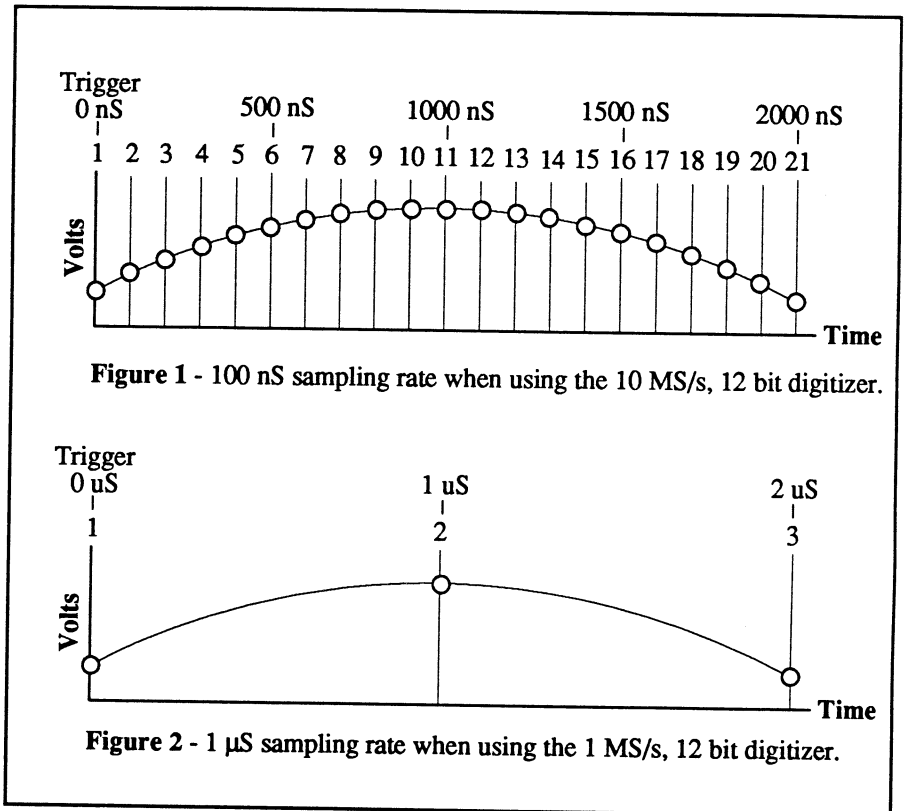

MODEL	DIGITIZERS INSTALLED	SAMPLING RATES
Pro 10 Pro 20	Two 1 MS/s, 12 bit	1 μ S
	Four 1 MS/s, 12 bit	1 μ S
Pro 30 Pro 40	Two 10 MS/s, 12 bit	100 nS
	Four 10 MS/s, 12 bit	100 nS
Pro 50 Pro 60	Two 200 MS/s, 8 bit	5 nS
	Four 200 MS/s, 8 bit	5 nS
Pro 90 (see Note 1)	Two 1 MS/s, 12 bit	1 μ S
	Two 10 MS/s, 12 bit	100 nS
	Two 200 MS/s, 8 bit	5 nS

Table 1 - Sampling Rates

Note 1: The Pro 90 Model is configured with two digitizers of one type and two of another, thus allowing the instrument to simultaneously capture signals with dual sampling rates. For example, it can be configured with two 10 MS/s, 12 bit digitizers and two 200 MS/s, 8 bit digitizers (see Chapter 27 for additional information).

VARYING THE TIME PER POINT

Assume the input signal is being sampled once every 100 nS as shown in Figure 1. The following examples illustrate the effect of increasing the Time Per Point setting while the Sweep Length value remains fixed at 1000 data points.

Note: Due to space limitations, only the first 21 of the total 1000 data points on the screen will be discussed.

Figures 2 through 4 show you how longer records of the input signal are captured by increasing the Time Per Point setting.

When the Time Per Point is equal to the sampling rate as in Figure 2, it will take 2000 nS to digitize all 21 samples. Thus, you will have a record length of 2000 nS.

Figure 3 shows that alternate samples are digitized for display when the Time Per Point setting is twice the sampling rate. Since it now takes 4000 nS to define the first 21 data points, the record length is twice as long as the 2000 nS record in Figure 2. Assuming that the signal is repetitive, you will have captured a second cycle of the input signal (grayed portion in Figure 3) for display by the time the 21st data point is defined.

Figure 4 shows that every fifth sample is digitized when the Time Per Point setting is five times the sampling rate. It now takes 10,000 nS before all 21 data points are defined, resulting in a record length five times longer than the 2000 nS record length in Figure 2. Again, assuming that the signal is repetitive, you will have captured four additional cycles (grayed portion in Figure 4) for display by the time the 21st data point is defined.

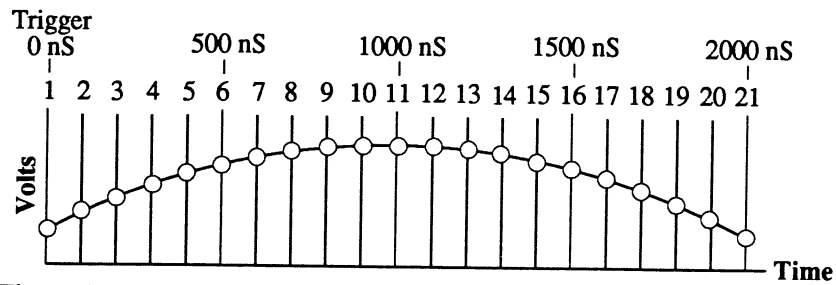

Figure 1 - Analog input signal superimposed with the 100 nS sampling rate. The Time Per Point setting will determine which samples are digitized.

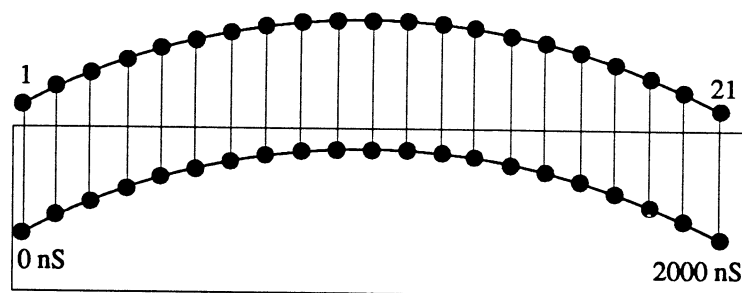

Figure 2 - Each of the 21 samples are displayed by the first 21 data points when Time Per Point = 100 nS and Sweep Length = 1000.

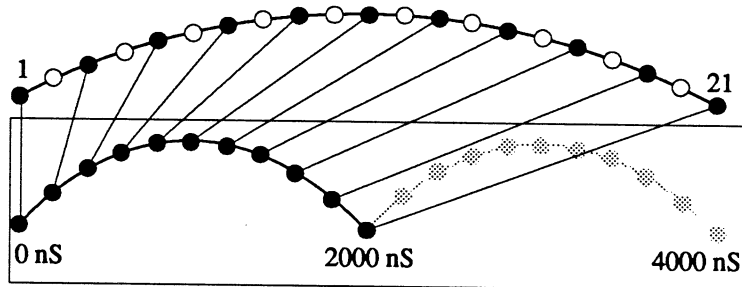

Figure 3 - Alternate samples (black dots) are digitized when Time Per Point = 200 nS and Sweep Length = 1000. Undigitized samples (white dots) are discarded.

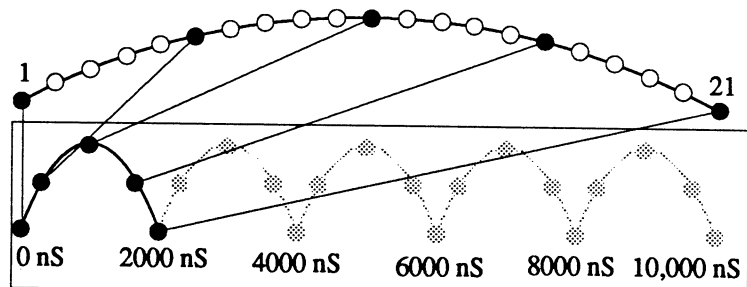

Figure 4 - Every fifth sample (black dots) is digitized when Time Per Point = 500 nS and Sweep Length = 1000. The undigitized samples (white dots) are discarded.

VARYING THE SWEEP LENGTH

Assume the input signal is being sampled once every 100 nS as shown in Figure 1. Increasing the Sweep Length to values larger than 1000 allows you to capture longer records with faster Time Per Point settings for higher time resolution inspections.

Note: Since the Time Per Point and sampling rate are identical (100 nS), every sample is digitized. However, not all of the digitized samples can be displayed at the same time when the Sweep Length setting exceeds the 1000 data point limit of the screen.

Before continuing, note that Figures 4 on both of these pages have record lengths equal to 10,000 nS. However, note that only every fifth sample is digitized and stored in memory (the undigitized samples, white dots, are discarded). Now look at Figure 4 on this page, every sample has been digitized and stored in memory. Since, in this example, it will take 5000 digitized samples to complete one full sweep and the screen's horizontal resolution only allows a maximum of 1000 data points, only every fifth digitized sample is displayed when Horizontal Expansion is turned off. However, even though you can only see 1000 data points on the screen, you can still decode all 5000 digitized samples stored in memory.

The 4000 "undisplayed" data points in this example begin to appear on the screen as you employ Horizontal Expansion. This feature is further described on the following page.

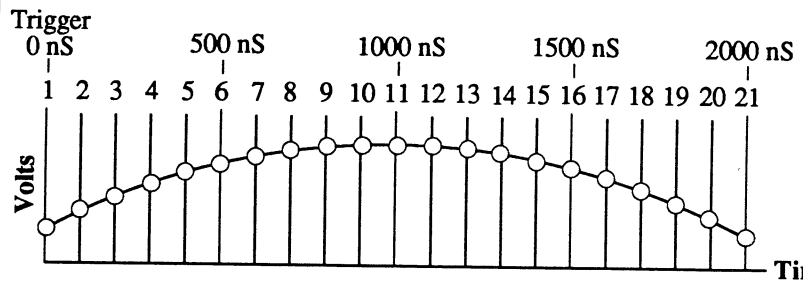

Figure 1 - Analog input signal superimposed with the 100 nS sampling rate. The Sweep Length setting will determine which of the samples are digitized.

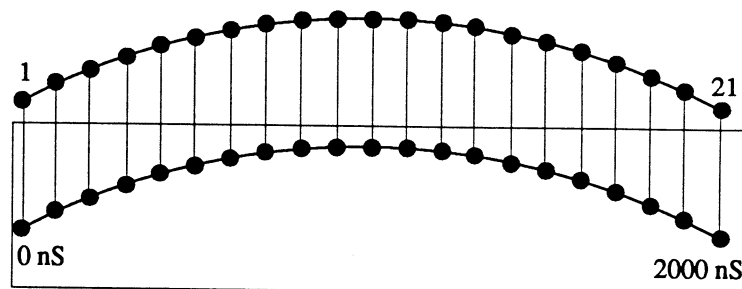

Figure 2 - Each of the 21 samples are displayed by the first 21 data points when Time Per Point = 100 nS and Sweep Length = 1000.

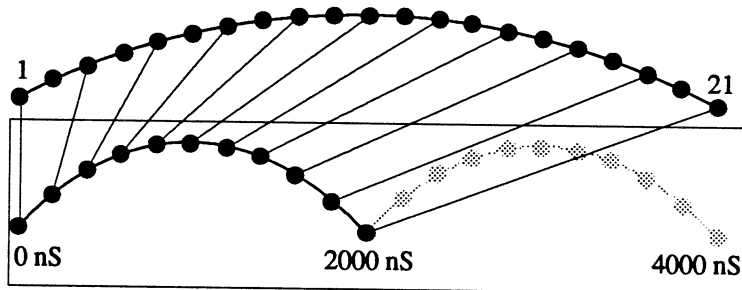

Figure 3 - Alternate digitized samples are displayed when Time Per Point = 100 nS and Sweep Length = 2000. See Note 1 below.

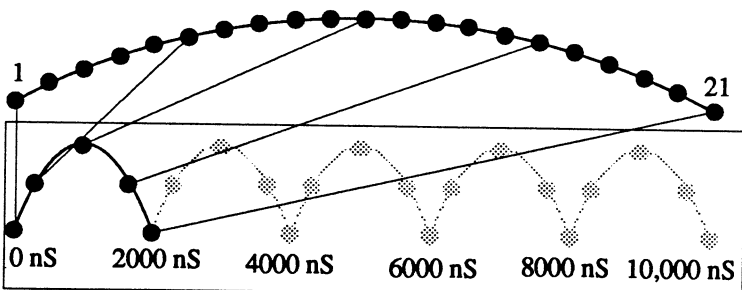

Figure 4 - Every fifth digitized sample is displayed when Time Per Point = 100 nS and Sweep Length = 5000. See Note 1 below.

Note 1: All of the digitized samples in Figures 3 and 4 above can still be inspected, even though they are not currently displayed on the screen when Horizontal Expansion is turned off. This is further discussed on the next page.

Horizontally Expanding the Captured Waveform

Note: Also see "Horizontal Expansion Button," *Chapter 9*.

The examples on the next page further illustrate why you should consider combining longer sweep lengths with faster Time settings (Waveform 2) rather than shorter sweep lengths with slower Time settings (Waveform 1).

Waveform 1 was captured with a Sweep Length of 1000 data points and a Time Per Point setting of 500 nS. Waveform 2 was captured with a Sweep Length of 5000 data points and a Time Per Point setting of 100 nS. These settings resulted in identical sweep times of 500 μ S.

Figures 1 and 2 on this page summarize what has already been discussed on the previous two pages.

Figure 1a on the next page is comprised of 1000 digitized samples, all of which are displayed on the screen. Figure 2a is comprised of 5000 digitized samples. You can decode all 5000 digitized samples, but only every fifth digitized sample is displayed because of the screen's 1000 data point horizontal resolution limit.

Figures 1b and 2b show the result of horizontally expanding each waveform for the first time. Figure 1b only provides 500 data points of information while Figure 2b provides 2000 data points of information. You can decode all 2000 data points, but only alternate points are displayed on the screen for a total of 1000.

Continue comparing Waveform 1 and Waveform 2 as they are further expanded. Note that the number of data points in Waveform 2 always surpasses those in Waveform 1 for a given expansion (i.e., 1000 in Figure 2c versus 200 in Figure 1c).

Also note that Waveform 1 cannot be expanded beyond Figure 1e because it has already reached the 50 data point minimum. Remember, horizontal expansion stops when only 50 data points are left on the screen! Waveform 2, on the other hand, can still be expanded two additional times before it reaches the 50 data point minimum in Figure 2g.

To further emphasize the advantage of Waveform 2 over Waveform 1, compare the enlarged areas in Figures 3 and 4.

Note that in Figure 3, the enlarged area only contains 11 data points after the fourth expansion while the enlarged area in Figure 4 provides you with 41 data points. Therefore, in this example, Figure 4 provides you with almost four times more data points of information.

Why Select One Method Over Another?

Data captured using longer sweeps lengths at faster Time settings provide higher time resolution displays when horizontal expansion is applied.

However, keep in mind that increasing the number of data points in the record (long sweep lengths) will result in longer processing times when the captured data is mathematically manipulated or output to an external device. That is, it is faster to export a 1,000 data point record than a 100,000 data point record. Therefore, is horizontal resolution important or is speed of processing more important?

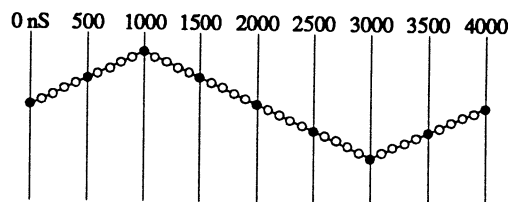

Figure 1 - Every fifth sample is digitized on Waveform 1 for display (black dots). Undigitized samples (white dots) are discarded.

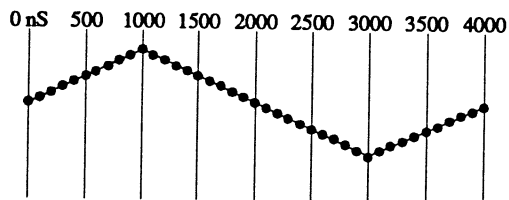
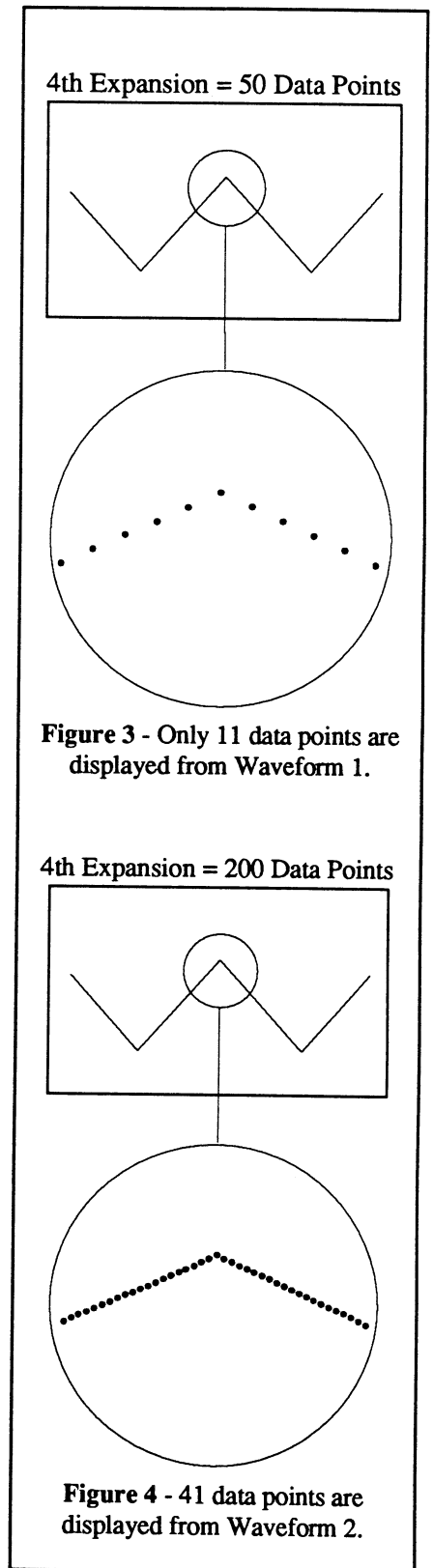
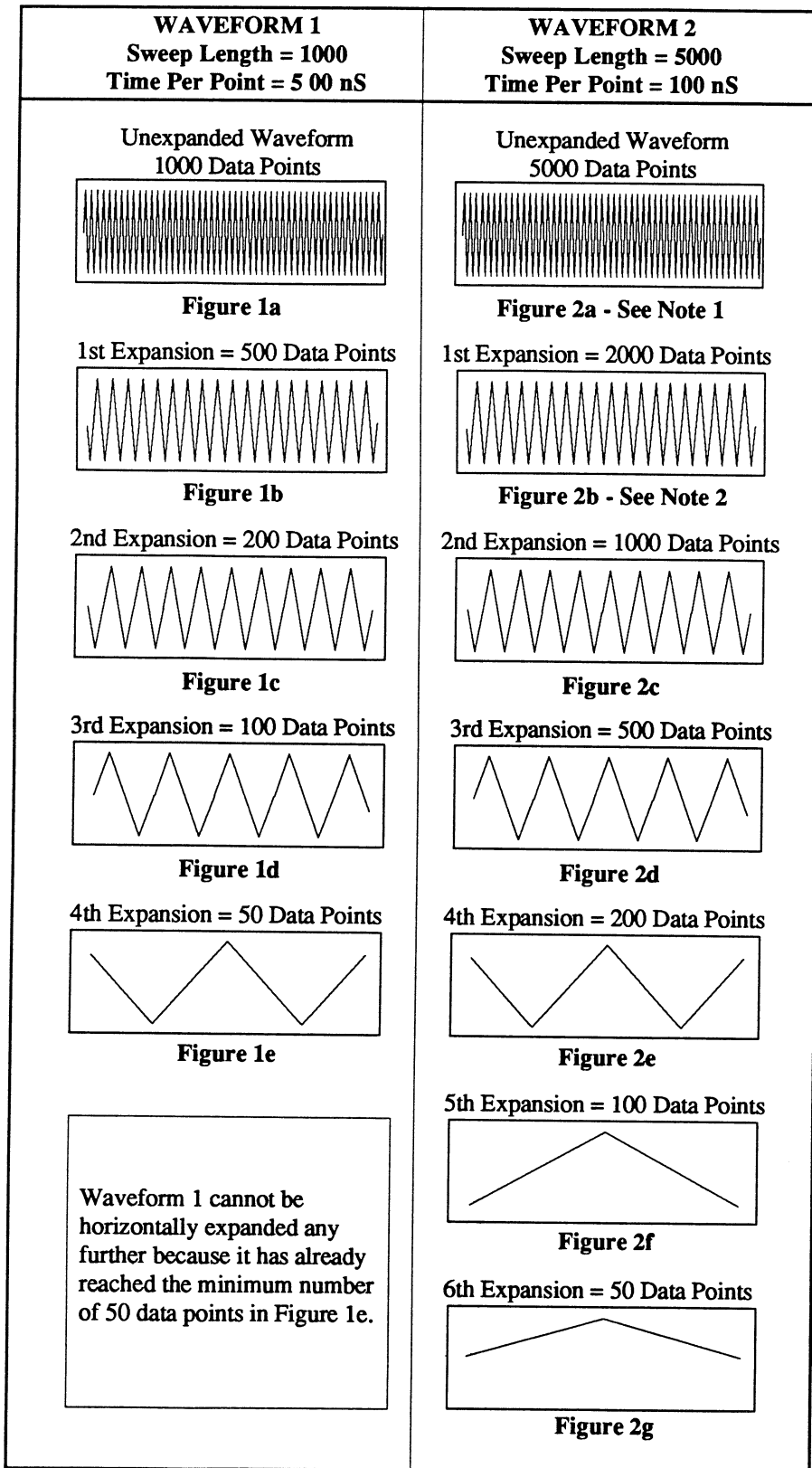

Figure 2 - Each sample is digitized and stored in memory on Waveform 2, thus providing you with five times more information within the same record length of 4000 nS. Only every fifth digitized sample is displayed on the screen when Horizontal Expansion is turned off, but each digitized samples can be selected for inspection.



Note 1: 5000 data points can be decoded, of which every fifth data point is displayed.

Note 2: 2000 data points can be decoded, of which only alternate data points are displayed.

SETTING THE SWEEP LENGTH

The Sweep Length function is accessed via the Menu button (see Chapter 17, Sweep Length). It allows you to select how many samples will be captured from the signal.

IMPORTANT: Sweep Length is fixed at 1000 points and cannot be changed when Snapshot FFT is on.

Setting the Sweep Length

1. Press the Menu button.
2. Using the Up or Down Cursor buttons, position the cursor box over ACQUISITION.
3. Press the Right Cursor button to move to the functions list.
4. If the selection box is not over Sweep Length (Figure 1), use the Up or Down Cursor button to move the box.
5. Press the Execute button. The Sweep Length Parameter Screen appears (Figure 2). The current value of the Sweep Length is shown below the NEXT field.
6. Use the Cursor buttons to move the pointer and change the selected digit.

CAUTION: Pressing the Execute button in the next step will cause a warning screen to appear. If Execute is pressed, all previously captured data will be cleared (including data stored in the Sweep Review Memory). Press the MENU button to exit without affecting the memories.

7. Press the Execute button.

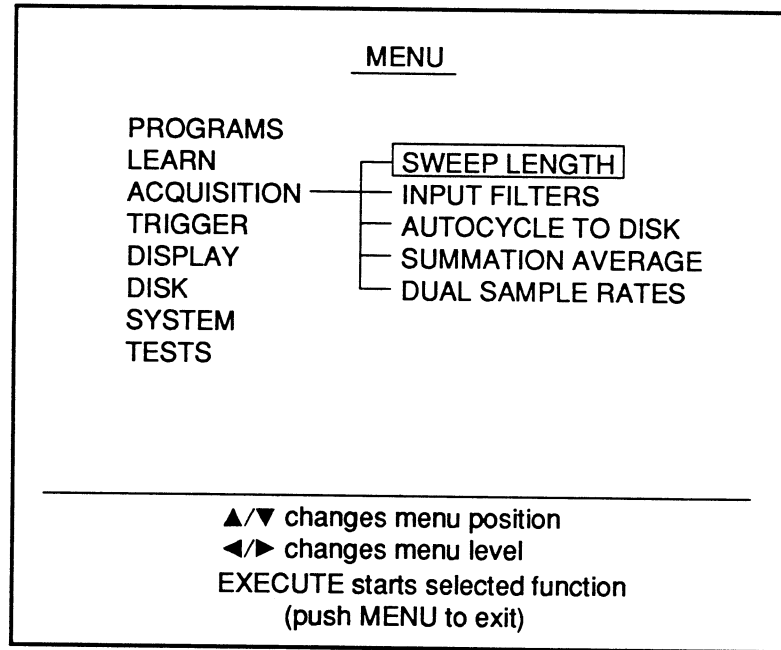

Figure 1 - Sweep Length Function Selected

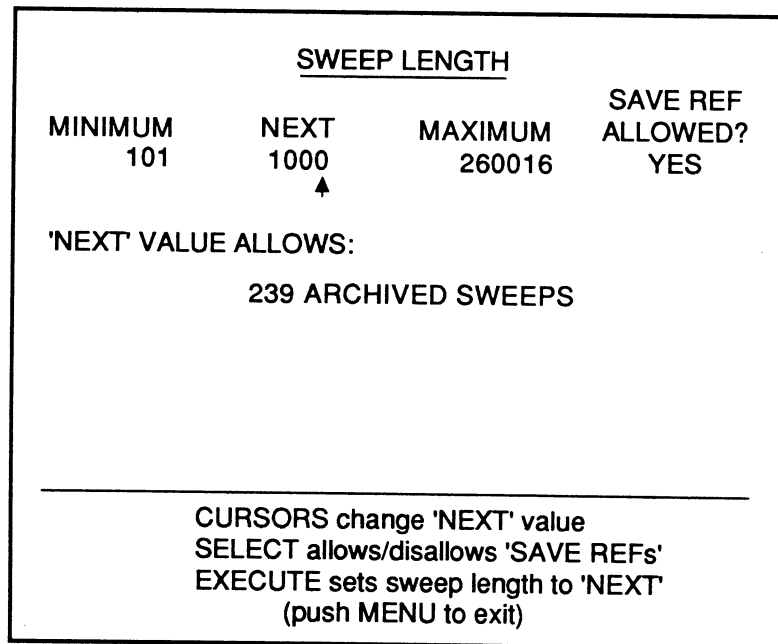

Figure 2 - Sweep Length parameter screen

SETTING THE TIME

Select the fastest Time setting that will capture and display one full cycle of a repetitive input signal. This will produce the highest resolution display of the captured input signal.

There are applications, however, when it is necessary to capture several cycles of a recurrent signal. For example, when trying to isolate noise spikes, erratic signals, etc.

Calculating the Sweep Time

To determine the sweep time, multiply the value displayed in the NEXT field of the Sweep Length menu by the Time readout setting.

Note: The current Sweep Time can be read directly from the Status display when you press the Status button.

EXAMPLE

Figure 1: A repetitive analog input signal with a duty cycle of 1 millisecond.

Figure 2: With a Time setting of $1\ \mu\text{S}$ and a Sweep Length of 1000 data points, one cycle is captured for display.

$$1000\ \text{points} \times 1\ \mu\text{S} = 1\ \text{mS sweep}$$

Figure 3: Increasing the Time setting to $2\ \mu\text{S}$ results in a display of two full cycles of the input signal.

$$1000\ \text{points} \times 2\ \mu\text{S} = 2\ \text{mS sweep}$$

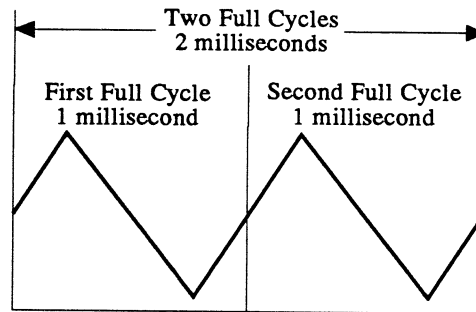

Figure 1 - Analog Input Signal

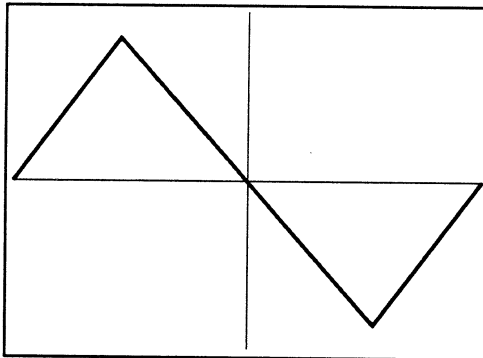

Figure 2 - One cycle captured with TIME = $1\ \mu\text{S}$

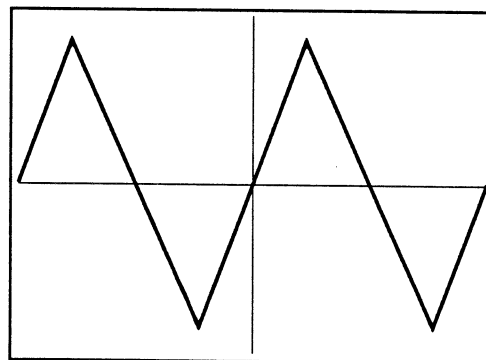

Figure 3 - Two cycles captured with TIME = $2\ \mu\text{S}$

EXTERNAL CLOCK

You can input an external clock TTL signal (approx. 0 to 4 volts) to the rear panel External Clock input BNC when a nonstandard (or nonrepetitive) time-per-point setting is desired and then turn the front panel TIME control fully counterclockwise until "EXT" appears on the Seconds readout.

For example, if you want to capture a sample every 3 μ S, you will have to input a 3 μ S clock to the External Clock input BNC and then display "EXT" on the Seconds readout because you cannot select 3 μ S via the front panel Time control.

Also see *Chapter 25, Rear Panel Controls, External Clock Input BNC*.

Chapter 11

THE XY/YT

BUTTON

The YT Display Mode	11-3
Inspecting YT Displays	11-3
Multiple YT Waveform Displays	11-3
The XY Display Mode	11-4
The XY Definition Screen	11-4
Defining the XY Axes	11-5
Horizontal Expansion OFF before Selecting XY	11-6
• Expanding a Full XY Display Mode Waveform	11-7
Horizontal Expansion ON before Selecting XY	11-8
• Expanding a Segmented XY Display Mode Waveform	11-9

This chapter describes how to display captured waveforms as voltage functions of time (YT mode) or display one waveform as a function of another (XY mode). It also includes the description for the Auto Set-up function.

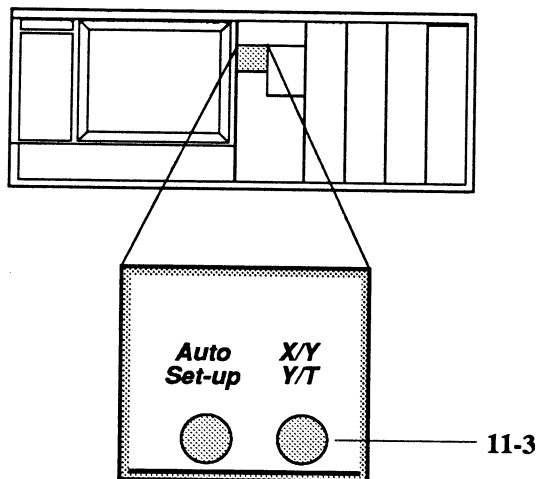

THE Y/T DISPLAY MODE

Waveforms are displayed as voltage functions of time (Figure 1) when the Y/T display mode is selected.

Inspecting Y/T Displays

The left numerics decode time coordinates selected by the vertical cursor and the right numerics decode voltage levels selected by the horizontal cursor.

When Autocenter is off, press the Left/Right Cursor buttons to move the horizontal cursor and the Up/Down Cursor buttons to move the vertical cursor.

When Autocenter is on, press the Left/Right Cursor buttons to make the crosshair (formed by the horizontal and vertical cursors) trace the selected waveform.

Note: Pressing the Up/Down Cursor button automatically turns off the Autocenter mode.

The waveform passes through the crosshair locked at screen center when the Left/Right Cursor button is pressed and Autocenter, Vertical Expansion and Horizontal Expansion are all turned on.

Multiple Waveform Displays

Press the Select button when multiple waveforms are displayed to select a different waveform for inspection (Figure 2). The selected waveform will appear brighter on the screen and the Channel Identifier will identify which channel is storing the waveform.

Note: Trigger View must be turned off to make selections.

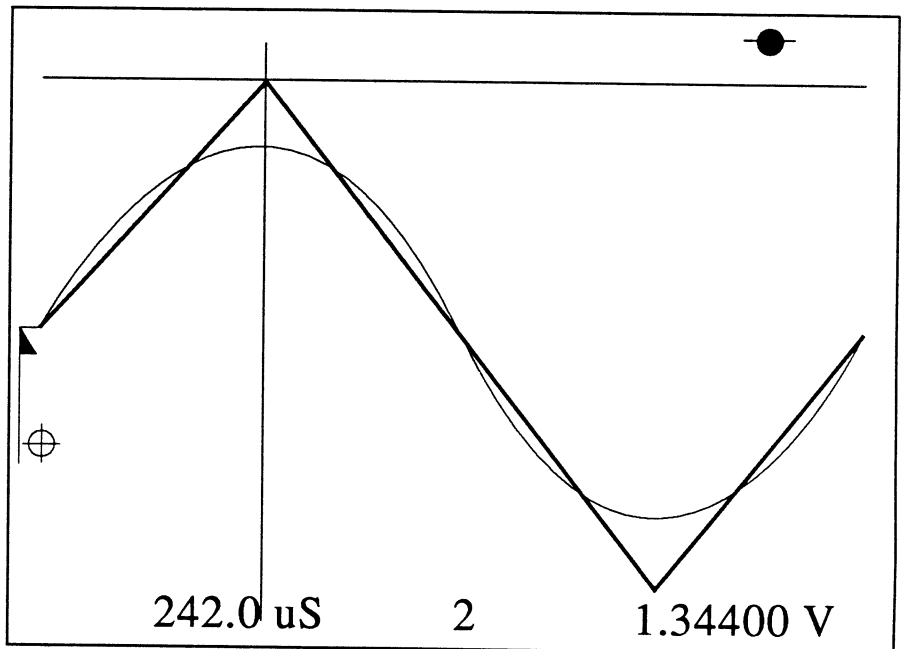

Figure 1 - YT display of two waveforms captured by channel 2 and channel 4. The number "2" in the lower center of the screen identifies that the triangle wave currently selected for inspection was captured by channel 2.

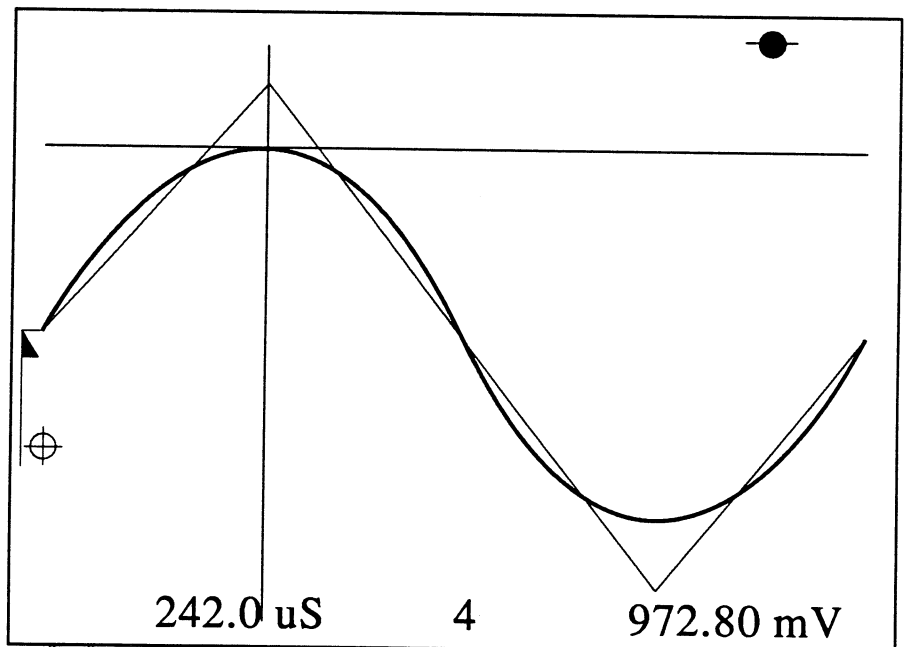

Figure 2 - The Select button was pressed to select the sine wave captured by channel 4 for inspection. Since Autocenter was also turned on, the crosshair moved to the channel 4 waveform.

THE X/Y DISPLAY MODE

The X/Y display mode displays the voltage values of one waveform plotted as a function of another (Figure 1). Up to four XY waveforms can be displayed simultaneously on the screen for inspection.

The XY Definition Screen

Press the XY/YT button while in the YT display mode to view the Current XY Display Settings screen (Figure 2).

The XY Display definition screen defaults to the last settings you entered when the XY Display Mode is selected.

After you have defined the new axes (see the next page), press the XY/YT button to view the new XY waveform(s) display.

The X/Y display mode can be used in either the Hold Mode (Hold Last LED on, Live LED off) or the Live Mode. Viewing XY waveform displays while in the Live Mode allows you to see the affects of altering the input signals' characteristics each time a sweep is triggered.

Exiting the XY Display Mode

To return to the YT display mode from an XY display, press the XY/YT button.

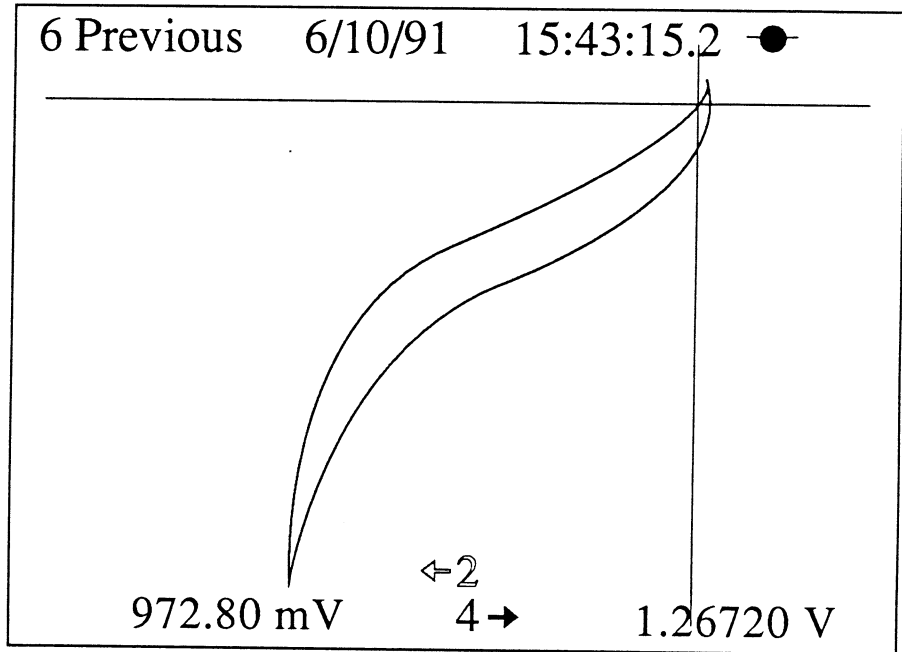

Figure 1 - XY display of two waveforms stored in channel 2 and channel 4. In this example, the left numerics is decoding voltage values from channel 2. The "2 and arrow" are highlighted to show that the waveform in channel 2 is archived in the Sweep Review Memory. To view the origin of the channel 4 waveform, press the Select button until the "4 and its arrow" are highlighted.

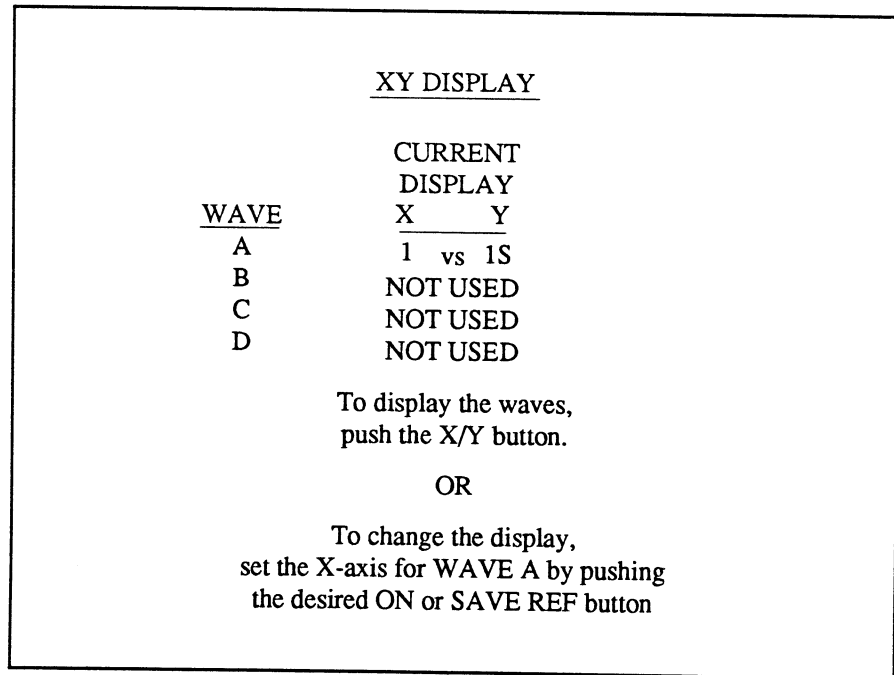

Figure 2 - Current XY Display Settings Screen

Defining the XY Axes

Any combination of Channel and Save Ref waveforms can be intermixed for display (e.g., 1 vs 2, 4 vs 1, 1S vs 3, etc.).

Assignments are made by pressing the desired channel On or Save Ref buttons. WAVE A will always be defined first, then WAVE B, WAVE C and finally WAVE D.

Note: SAVE REF must be enabled on the SWEEP LENGTH menu (*Chapter 18*) to select a Save Ref waveform. In addition, if any editing must be done (e.g., correcting a wrong entry), you must return to the YT mode, select the XY mode again and then start over beginning again with WAVE A.

1. Assign the x-axis waveform for WAVE A by pressing the desired Channel On or Save Ref button. The New XY Display screen will appear showing the Old Display settings and a New Display settings field.
2. Assign the y-axis waveform for WAVE A by pressing the desired Channel On or Save Ref button.
3. Continue to define each additional XY waveform for WAVE B, C, and D if desired in the same manner described in steps 1 and 2.
4. When all of the desired XY waveforms have been defined, press the XY/YT button to view the resulting XY waveform display.

Note: The XY waveform display will appear automatically as soon as the WAVE D - Y-axis waveform is defined.

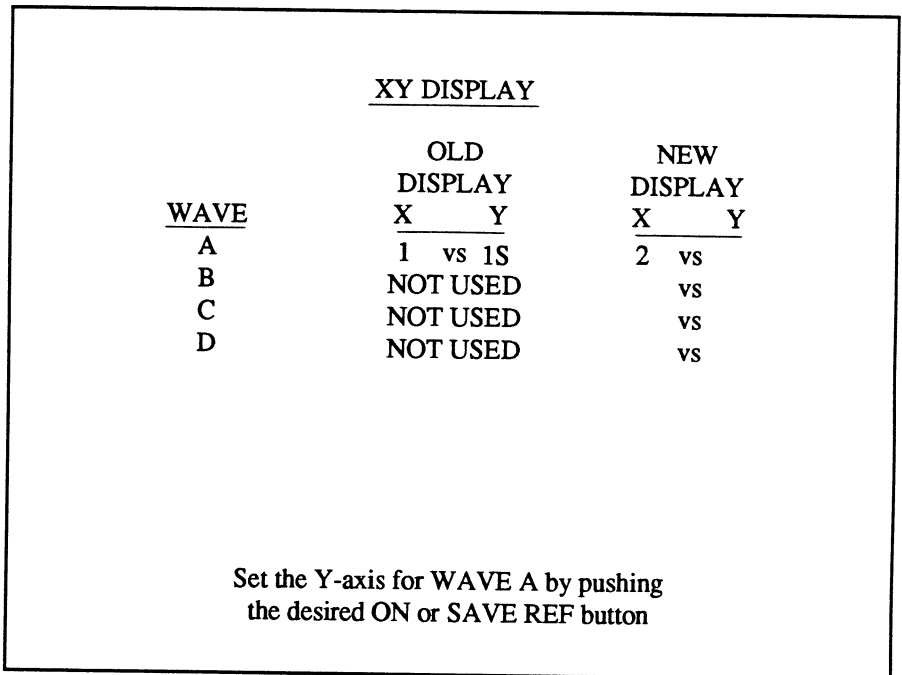

Figure 3 - The channel 2 On button was pressed to redefine the X-axis for WAVE A. You are now prompted to define the Y-axis waveform for WAVE A.

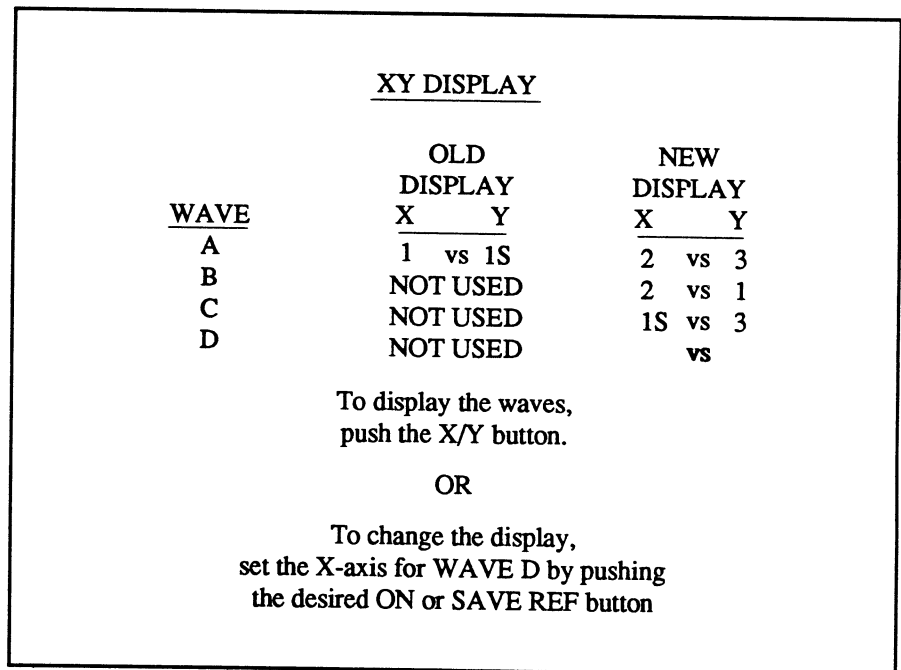

Figure 4 - Three XY waveforms will be displayed with the above settings when the XY/YT button is pressed.

Horizontal Expansion Turned OFF Before Selecting the XY Display Mode

If the YT Display was not horizontally expanded when the XY display mode was turned on, a full XY waveform will appear.

Autocenter can be turned on or left off to decode values from the displayed XY waveform.

Turning Autocenter on allows you to decode x-axis and y-axis values simultaneously by pressing the Left/Right Cursor button. It is also visually helpful when multiple XY waveforms are being displayed because the crosshair will trace the waveform selected for inspection.

Note: Autocenter automatically turns off when the Up/Down Cursor button is pressed.

If Autocenter is turned off, use the Up/Down Cursor buttons to decode y-axis values and the Left/Right Cursor buttons to decode x-axis values.

Figure 1 - Unexpanded display of two YT waveforms with Autocenter turned on.

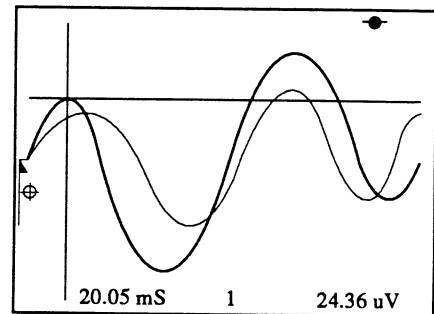

Figure 1

Figure 2 - Corresponding full XY waveform display of the two waveforms in Figure 1.

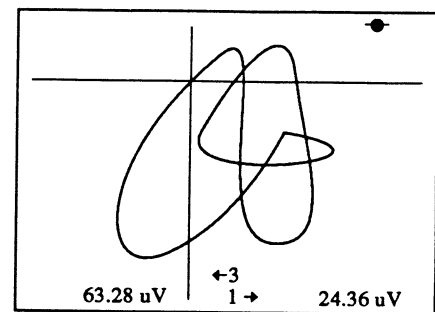

Figure 2

Figure 3 - The Right Cursor button was pressed and held, causing the crosshair to begin tracing the waveform as the numerics decode the x-axis and y-axis values simultaneously.

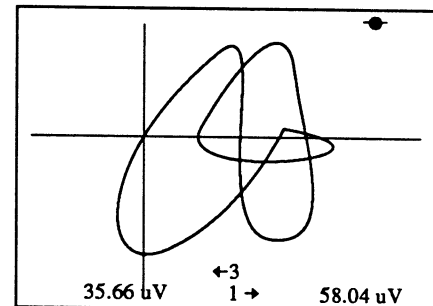

Figure 3

Figure 4 - Turning off Autocenter and then pressing and holding the Right Cursor button causes the vertical cursor to move to the right. Note that only the x-axis numerics changed since Figure 3. Pressing the Up Cursor button causes the horizontal cursor to move upwards on the screen thus affecting only the y-axis numerics values.

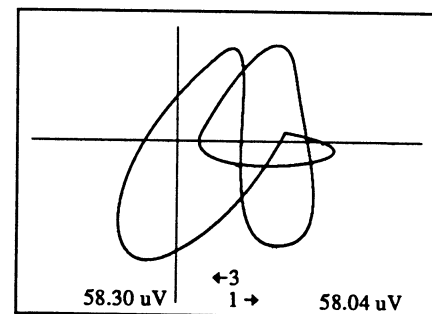

Figure 4

Expanding a Full XY Display Mode Waveform

Once in the XY display mode, you can expand the displayed XY data for closer inspections.

Note: Adding expansion while in the XY display mode does NOT affect the YT waveform. This only expands the XY data you are currently viewing on the screen.

- **XY Expansion Factors**

The expansion factors used for both Horizontal and Vertical Expansion are: 1.5, 2, 3, 6, 10, 16, 24, 32, 64, 128, 256, 512

For example, the first time an expansion button is pressed, the waveform expands to 1.5 times its original size. The second time the button is pressed, the waveform expands to twice its original size. The waveform can be expanded until the maximum expansion factor of 512 times the original waveform size has been reached.

If Autocenter is turned on and both Horizontal and Vertical Expansion is applied, the waveform will move through the crosshair locked at screen center when the Left/Right Cursor buttons are pressed.

Pressing the Up/Down Cursor button automatically turns Auto-center off and moves the waveform vertically on the screen.

Figure 1 - A full XY waveform display with Autocenter turned on.

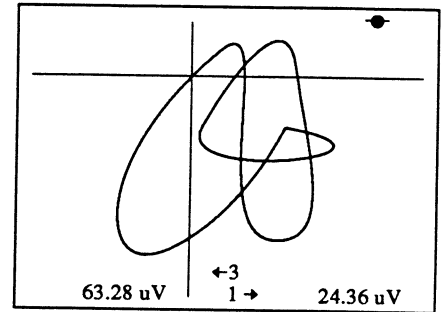

Figure 1

Figure 2 - The crosshair and area of interest moved to screen center when Horizontal & Vertical Expansion was added.

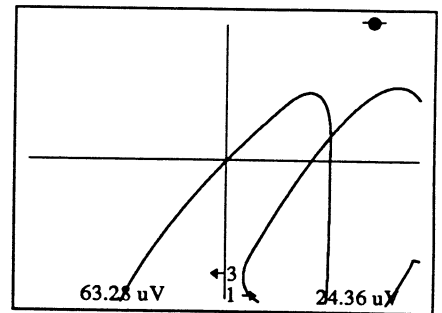

Figure 2

Figure 3 - The waveform passes through the crosshair when the Right Cursor button is pressed. Note that both the x-axis and y-axis numerics have changed since Figure 2.

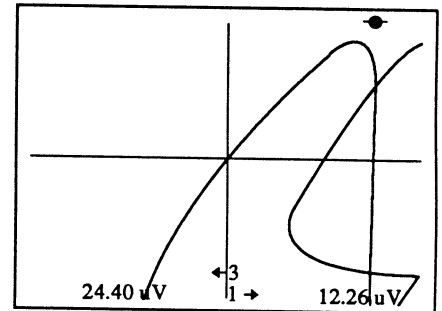

Figure 3

Figure 4 - Autocenter was turned off and the Right Cursor button was pressed, thus moving the XY waveform towards the left edge of the screen. Note that only the x-axis numerics changed since the example in Figure 3.

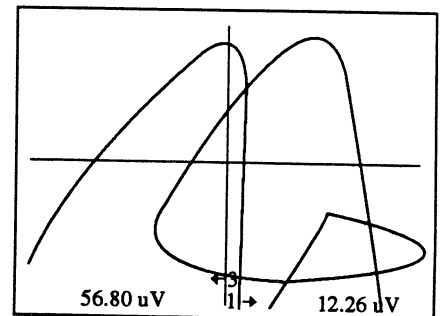

Figure 4

Horizontal Expansion Turned ON Before Selecting the XY Display Mode

If horizontal expansion is turned on while in the YT display mode and the XY display mode is selected, only the expanded portions of the YT waveforms will be plotted against each other. This will cause only a "segment" of the XY waveform to be displayed.

Unlike the previously discussed full XY Waveform displays, Autocenter greatly affects the manner in which you can inspect a "segmented" XY display. See the examples on the next page.

When Autocenter is turned off, the Expansion Bracket remains locked at its current position when the Cursor buttons are pressed.

When Autocenter is turned on, the Expansion Bracket will slide across the waveform, thus selecting different portions of the YT waveforms to create new XY segments.

Expanding an XY Segment

As with a full XY Waveform display, you can increase display expansion for closer inspections.

Note: Adding expansion while in the XY display mode does NOT affect the YT waveform. This only expands the XY data you are currently viewing on the screen.

- XY Expansion Factors**

The expansion factors used for both Horizontal and Vertical Expansion are: 1.5, 2, 3, 6, 10, 16, 24, 32, 64, 128, 256, 512

For example, the first time an expansion button is pressed, the segment will expand to 1.5 times its original size. The segment can be expanded until the maximum expansion factor of 512 times the original segment size has been reached by repeatedly pressing the Expansion button.

If Autocenter is turned on and both Horizontal and Vertical Expansion is applied, the segment will move through the crosshair locked at screen center when the Left/Right Cursor button is pressed.

Pressing the Up/Down Cursor button automatically turns Autocenter off and moves the waveform vertically on the screen.

Pressing the Left/Right Cursor button moves the waveform across the screen.

Note: Only the selected YT waveform appears in the Expansion Marker at the bottom of the screen. To view the other waveform(s), press the Select button.

Figure 1 - Before the XY mode was selected, The YT waveforms were horizontally expanded.

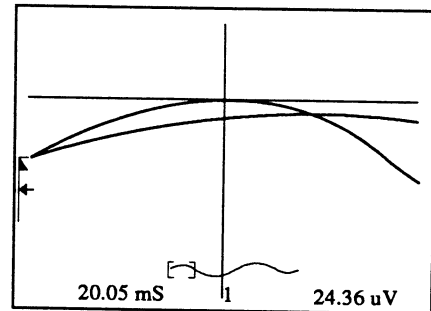

Figure 1

Figure 2 - The black portion of the XY waveform represents the corresponding XY segment while viewing data in the XY mode. The Expansion Brackets show you which portions of the YT waveforms in Figure 1 are being used to create the XY segment.

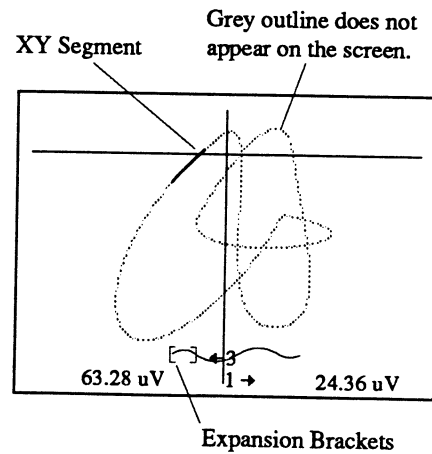

Figure 2

**Example 1:
Inspecting an XY Segment
Display with Autocenter
Turned OFF**

Figure 3 - Pressing the Left Cursor button with Autocenter turned OFF moves the vertical cursor towards the left edge of the screen. Use the Left or Right Cursor buttons to decode the x-axis values and the Up or Down Cursor buttons to decode the y-axis values. Note that the Expansion Brackets are still positioned over the same portion of the waveform as in Figure 2 on the previous page.

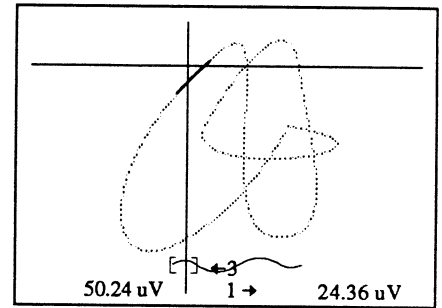

Figure 3

Figure 4 - Horizontal and Vertical Expansion was applied. Note that the size of the Expansion Brackets have not changed. Thus, you are expanding the XY segment, but you have not altered the size or position of the Expansion Brackets originally selected in Figure 2 on the previous page.

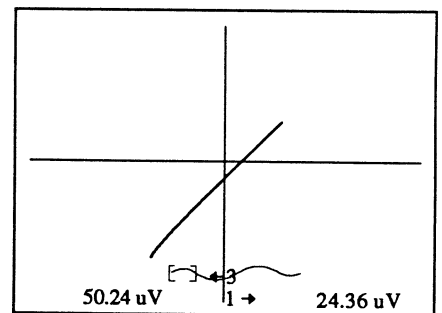

Figure 4

**Example 2:
Inspecting an XY Segment
Display with Autocenter
Turned ON**

Figure 5 - Pressing the Left Cursor button with Autocenter turned ON causes the XY segment, in effect, to trace the XY waveform. Both the x-axis and y-axis values will be decoded simultaneously when the Left or Right Cursor buttons are pressed. Note that the Expansion Brackets have moved since Figure 2 on the previous page. You are now viewing different portions of the YT waveforms.

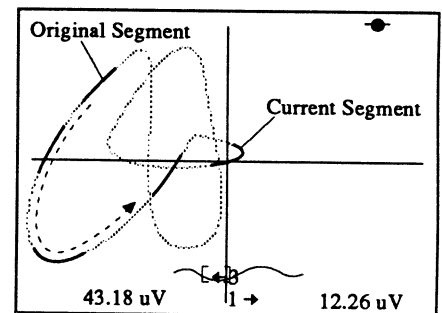

Figure 5

Figure 6 - The XY segment display in Figure 5 was horizontally and vertically expanded. Note neither the size nor the position of the Expansion Brackets have changed since Figure 5 above.

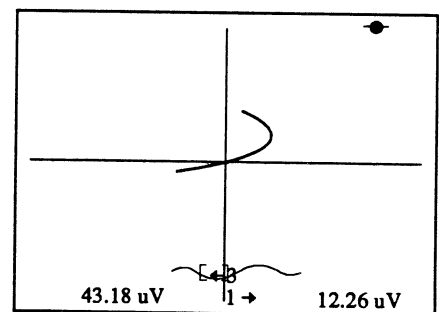

Figure 6

Chapter 12

THE CHANNEL CONTROLS

Channel ON/OFF Button	12-3
Amplifier Input BNCs	12-3
Differential Amplifier Mode	12-3
Single-Ended Amplifier Mode	12-3
Coupling Buttons	12-4
Save Ref Button	12-4
Identifying a Save Reference Waveform	12-4
Save Referencing a Waveform	12-4
Volts Button & Readout	12-5
The Test Probes	12-5
Volts-Per-Level & Volts-Per-Division	12-6
Selecting the Volts Full Scale Range	12-6
Position Control	12-8

This chapter describes the controls which determine the basic configuration of each individual channel.

It includes a description of the input amplifiers, how the input signals can be coupled to the amplifiers, and the input voltage range selector.

It also includes descriptions for vertical repositioning of live signals as well as how a waveform can be saved in memory for comparison with a live signal.

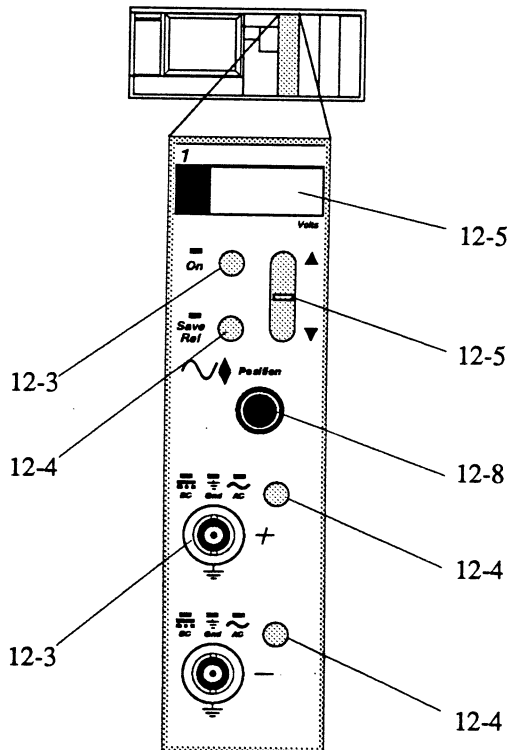

CHANNEL ON/OFF BUTTON

Press the channel ON button to turn the channel on or off. The channel is turned on when the ON LED is illuminated.

LED ON: The channel will capture new data if the LIVE LED is turned on and a valid trigger is received. Data captured by the channel is stored in memory and displayed on the screen.

LED OFF: The channel cannot capture any new data. Data previously captured by the channel remains in memory, but is not displayed if in the YT display mode. If in the XY display mode, the System will be forced into the YT mode if you turn off a channel (or Save Referenced waveform) leaving you only half of the required waveforms to comprise an XY display. For example, if you are displayed channel 1 vs. channel 2 and then turn channel 2 off, the system will be forced back into the YT mode.

Note: When all of the channels and their respective Save functions are turned off, the display screen provides the following information: the number of bits and maximum sampling rate for each channel, PROM version, and the date and time.

AMPLIFIER INPUT BNCs

Signals are input to high impedance (1 megohm) amplifiers via the input BNCs.

The high input impedances allow high impedance signal sources to be measured because of the amplifier's light loading effects.

CAUTION: Always ensure the input signal does not exceed the maximum allowable input voltage, with respect to ground, listed in the Specifications towards the rear of this manual.

Note: Channels configured with two input BNCs can be operated in either the Differential Amplifier or Single-ended Amplifier mode. Channels configured with only one input BNC can only be operated in the Single-Ended Amplifier Mode.

Differential Amplifier Mode

Note: The channel must be configured with two input BNCs to use the differential amplifier mode.

The differential amplifier mode displays the voltage differences between two signals simultaneously input to an individual channel's (+) and (-) input BNCs.

To select the differential mode:

1. Input one signal to the channel's (+) input BNC and another to the (-) input BNC.
2. Press the Coupling button adjacent to the input BNC until the desired coupling (AC or DC) LED lights.

Single-Ended Amplifier Mode

The single-ended amplifier mode displays the input signal's voltage characteristics as they appear at the channel's input BNC.

To select the single-ended mode:

1. Input only one signal to either of the channel's input BNCs (if configured with two BNCs).
2. Press the Coupling button adjacent to the input BNC until the desired coupling (AC or DC) LED lights.
3. Ground the unused input BNC (if configured with two BNCs) by pressing the adjacent Coupling button until the Gnd LED lights.

COUPLING BUTTONS

Press the input Coupling buttons (adjacent to the input BNCs) to select whether or not signals will be input to the amplifiers and, if input to the amplifiers, whether DC signal components will be blocked.

Note: For purposes of this instrument, DC signals are defined as voltages varying at approximately 1.5 Hertz or less. AC signals vary at a rate greater than 1.5 Hertz.

Selecting the Input Coupling

Press the Coupling button until the desired coupling LED above the input BNC lights.

DC: Both AC and DC signals enter the amplifier.

AC: AC signals enter the amplifier. DC signals are blocked.

GND: Grounds the amplifier's input, thus blocking all signals from entering the amplifier.

Always ground unused inputs by pressing the Coupling button until the Gnd LED lights. Unwanted "noise" may affect the results if they are left ungrounded.

SAVE REF BUTTON

Press the Save Ref button to turn the Save Reference mode on (Save Ref LED on) or off. This feature allows you to compare the differences between a "saved" signal and a "live" signal.

Important: SAVE REF must be enabled in the Sweep Length Function screen to use the Save Reference mode (see *Chapter 17*). In addition, turning Save Ref on while its channel is on will redefine the Save Reference data.

When Save Ref is allowed in the Sweep Length function screen (*Chapter 17*), one sweep review memory segment is set aside for the saved waveform. Up to eight waveforms can be displayed simultaneously when all four channels and their Save Ref modes are turned on.

Identifying a Save Reference Waveform

The letter "S" suffix is added to the channel identifier when a saved waveform is selected for inspection. For example, Figures 2 and 3 show that the triangle waveform was saved because the Channel Identifier reads "1S."

To Save Reference a Waveform

1. With Save Ref turned off, capture the first input signal.
2. Press the Save Ref button. Two waveforms will appear when the next waveform is captured, one live and the other saved.

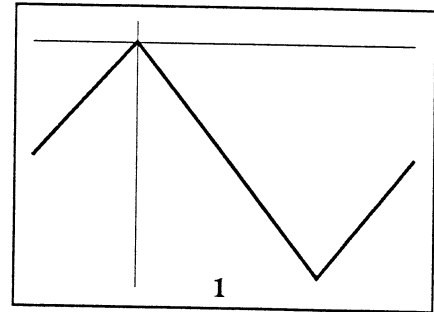

Figure 1 - A triangle wave was input to channel 1.

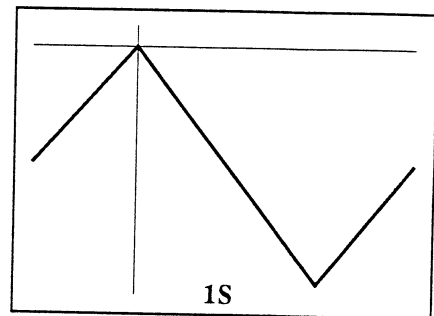

Figure 2 - Save Ref was turned on to save the triangle wave and the Select button was pressed. The channel identifier now reads 1S, identifying the waveform as a Save Ref waveform.

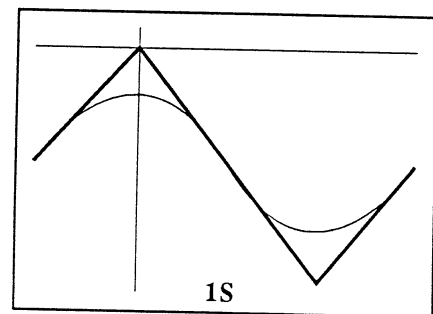

Figure 3 - The triangle wave input to channel 1 was then changed to a sine wave. Now the Save Ref triangle wave and Live sine wave can be viewed simultaneously on the screen.

VOLTS BUTTON

Selects the maximum full scale voltage that can be displayed without exceeding the screen's limits (see Figure 1). The Volts readout displays the selected voltage range.

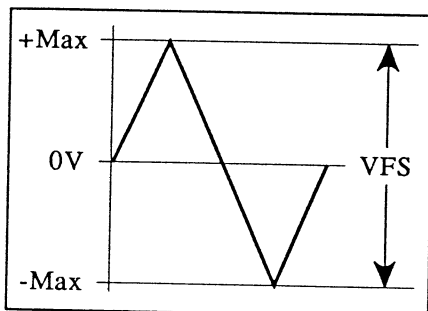

Figure 1 - Volts Full Scale (VFS)

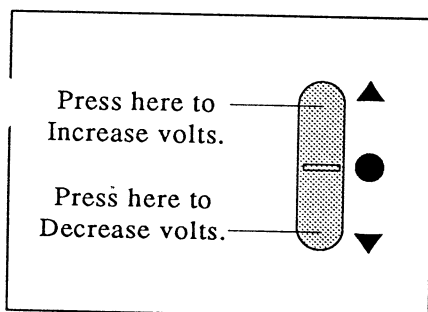

Figure 2 - Volts Button

VOLTS READOUT

The Volts readout displays the Volts Full Scale value selected by pressing the Volts button. The value displayed by this readout determines the maximum signal amplitude that can be captured by the instrument and be displayed without exceeding the display limits of the screen.

For example, assume that a 5.8 V peak-to-peak signal is being captured for display. Figure 3 illustrates the result when too low of a Volts setting is selected. Figure 4 illustrates the proper display when the Volts setting is set to the correct value.

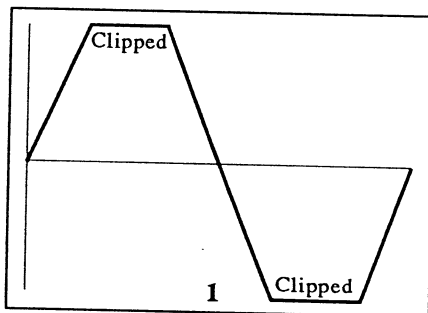

Figure 3 - The waveform peaks are clipped because the Volts readout was set for 3V which is less than the 5.8 V amplitude of the input signal.

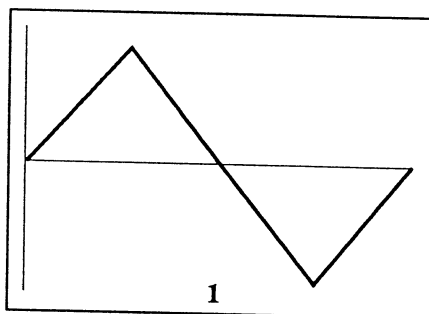

Figure 4 - The Volts setting was increased to 6 V, thus allowing the 5.8 V signal to be displayed within the screen's limits.

THE TEST PROBES

When using a x10 or x100 probe to input a signal to the instrument, the Vertical Scalar field must be changed accordingly.

Change the Vertical Scalar field to read 1.000 E+1 when using the x10 probe, and 1.000 E+2 when using the x100 probe. See Chapter 19, User Units Function for instructions on how to use the User Units Function accessed via the Menu button.

The maximum voltages that can be input to the instrument using the x10 and x100 probes available from Nicolet are:

X10 = 600V; DC + peak AC

X100 = 1,200V; DC + peak AC

The above voltage ratings are due to the probes' maximum input voltage specifications.

The Volts-Per-Level & Volts-Per-Division

Data points are displayed by up to 4,096 individual voltage levels when vertical expansion is turned off.

When the 0 volts level is set to screen vertical center when using a 12-bit digitizer (see Figure 1), positive voltages are displayed by 2,047 voltage levels and negative voltages by 2,048 voltage levels.

Table 1 tabulates the minimum voltage difference between adjacent levels when in the Cursor mode, and the Volts Per Division when in the Grid mode according to the Volts setting for the 14, 12, and 8-bit digitizers.

EXAMPLE

Figure 2 illustrates a detail of six individual voltage levels using the 12-bit digitizer as an example.

The Volts range was set to 6V, thus providing a Volts Per Level of 1.6 mV. Therefore, the minimum voltage difference between any two adjacent voltage levels that can be measured is equal to 1.6 mV when the Volts readout is set for 6.0V full scale.

If the Volts range had been set to 3V, then the minimum measurable voltage difference would be 800 μ V, thus doubling the voltage sensitivity of the instrument.

Selecting the Volts Full Scale Range

Select the lowest Volts setting that allows a maximum full scale display of the input signal without exceeding the screen's limits. This increases the amplifier's sensitivity due to the reduced volts-per-level factor. If the

Volts Range	Volts Per Level (Cursor Mode)			Volts Per Division (Grid Mode)		
	8-Bit	12-Bit	14-Bit	8-Bit	12-Bit	14-Bit
30 mV	not used	8 μ V	2 μ V	not used	3.75 mV	3.75 mV
60 mV	256 μ V	16 μ V	4 μ V	7.5 mV	7.5 mV	7.5 mV
1.20 mV	512 μ V	32 μ V	8 μ V	15 mV	15 mV	15 mV
300 mV	1.28 mV	80 μ V	20 μ V	37.5 mV	37.5 mV	37.5 mV
600 mV	2.56 mV	160 μ V	40 μ V	75 mV	75 mV	75 mV
1.2 V	5.12 mV	320 μ V	80 μ V	150 mV	150 mV	150 mV
3 V	12.8 mV	800 μ V	200 μ V	375 mV	375 mV	375 mV
6 V	25.6 mV	1.6 mV	400 μ V	750 mV	750 mV	750 mV
12 V	51.2 mV	3.2 mV	800 μ V	1.5 V	1.5 V	1.5 V
30 V	128 mV	8.0 mV	4 mV	3.75 V	3.75 V	3.75 V
60 V	not used	16.0 mV	4 mV	not used	7.5 V	7.5 V
120 V	not used	32.0 mV	8 mV	not used	15 V	15 V

Table 1 - Volts Per Level and Volts Per Division factors for 8-bit, 12-bit, and 14-bit digitizers

signal's amplitude is unknown, begin with the Volts readout set to 120V and then decrease the setting as required.

EXAMPLE

Figures 3 - 5: These illustrate the results when the Volts setting is set to 12V. The "noise" at the peaks of the signal were missed because the Volts Per Level is equal to 3.2 mV (Table 1) which is too high to capture the smaller voltage deviations of the "noise."

Figures 6 - 8: The Volts setting was lowered to 6V which, in turn, lowered the Volts Per Level to 1.6 mV (Table 1). Decreasing the Volts setting allows the scope to begin capturing the smaller voltage deviations.

Figures 9 - 11: The Volts setting was further lowered to 3V, providing a Volts Per Level of 800 μ V. The "noise" has been captured for display because the sensitivity is now low enough to capture and record the smaller voltage deviations.

14 bit, 12 bit, 8 bit

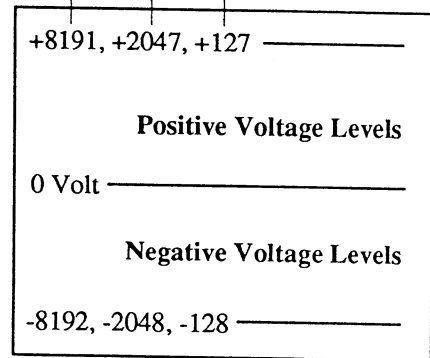

Figure 1 - Voltage Levels for 14-bit, 12-bit, and 8-bit digitizers.

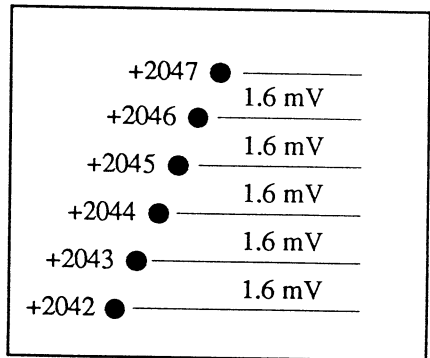

Figure 2 - Detailed view of the 1.6 mV levels when the Volts range is set to 6.0 V on a 12-bit digitizer.

VOLTS BUTTON

Selects the maximum full scale voltage that can be displayed without exceeding the screen's limits (see Figure 1). The Volts readout displays the selected voltage range.

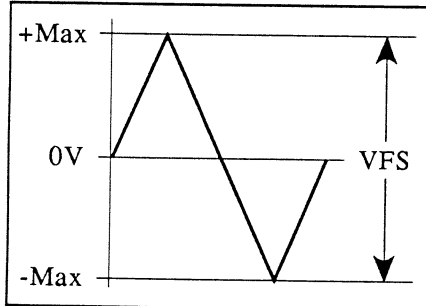

Figure 1 - Volts Full Scale (VFS)

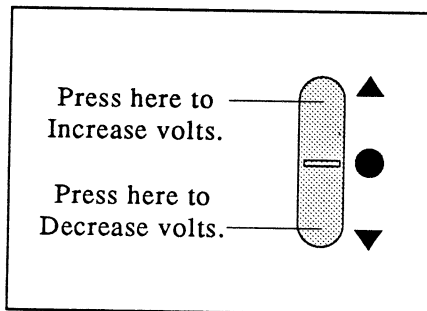

Figure 2 - Volts Button

VOLTS READOUT

The Volts readout displays the Volts Full Scale value selected by pressing the Volts button. The value displayed by this readout determines the maximum signal amplitude that can be captured by the instrument and be displayed without exceeding the display limits of the screen.

For example, assume that a 5.8 V peak-to-peak signal is being captured for display. Figure 3 illustrates the result when too low of a Volts setting is selected. Figure 4 illustrates the proper display when the Volts setting is set to the correct value.

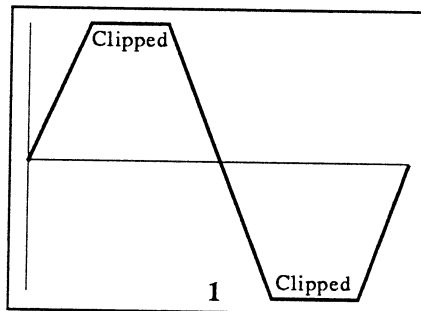

Figure 3 - The waveform peaks are clipped because the Volts readout was set for 3V which is less than the 5.8 V amplitude of the input signal.

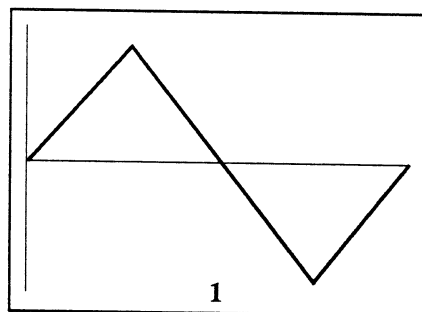

Figure 4 - The Volts setting was increased to 6 V, thus allowing the 5.8 V signal to be displayed within the screen's limits.

THE TEST PROBES

When using a x10 or x100 probe to input a signal to the instrument, the Vertical Scalar field must be changed accordingly.

Change the Vertical Scalar field to read 1.000 E+1 when using the x10 probe, and 1.000 E+2 when using the x100 probe. See *Chapter 19*, User Units Function for instructions on how to use the User Units Function accessed via the Menu button.

The maximum voltages that can be input to the instrument using the x10 and x100 probes available from Nicolet are:

X10 = 600V; DC + peak AC

X100 = 1,200V; DC + peak AC

The above voltage ratings are due to the probes' maximum input voltage specifications.

The Volts-Per-Level & Volts-Per-Division

Data points are displayed by up to 4,096 individual voltage levels when vertical expansion is turned off.

When the 0 volts level is set to screen vertical center when using a 12-bit digitizer (see Figure 1), positive voltages are displayed by 2,047 (126 for 8-bit) voltage levels and negative voltages by 2,048 (127 for 8-bit) voltage levels.

Table 1 tabulates the minimum voltage difference between adjacent levels when in the Cursor mode, and the Volts Per Division when in the Grid mode according to the Volts setting.

EXAMPLE

Figure 2 illustrates a detail of six individual voltage levels using the 12-bit digitizer as an example.

The Volts range was set to 6V, thus providing a Volts Per Level of 1.6 mV. Therefore, the minimum voltage difference between any two adjacent voltage levels that can be measured is equal to 1.6 mV when the Volts readout is set for 6.0V full scale.

If the Volts range had been set to 3V, then the minimum measurable voltage difference would be 800 μ V, thus doubling the voltage sensitivity of the instrument.

Selecting the Volts Full Scale Range

Select the lowest Volts setting that allows a maximum full scale display of the input signal without exceeding the screen's limits. This increases the amplifier's sensitivity due to the reduced volts-per-level factor. If the

Volts Range	8-Bit Digitizers		12-Bit Digitizers	
	Volts Per Level (Cursor Mode)	Volts Per Division (Grid Mode)	Volts Per Level (Cursor Mode)	Volts Per Division (Grid Mode)
30 mV	not used	not used	8 μ V	3.75 mV
60 mV	256 μ V	7.5 mV	16 μ V	7.5 mV
1.20 mV	512 μ V	15 mV	32 μ V	15 mV
300 mV	1.28 mV	37.5 mV	80 μ V	37.5 mV
600 mV	2.56 mV	75 mV	160 μ V	75 mV
1.2 V	5.12 mV	150 mV	320 μ V	150 mV
3 V	12.8 mV	375 mV	800 μ V	375 mV
6 V	25.6 mV	750 mV	1.6 mV	750 mV
12 V	51.2 mV	1.5 V	3.2 mV	1.5 V
30 V	128 mV	3.75 V	8.0 mV	3.75 V
60 V	not used	not used	16.0 mV	7.5 V
120 V	not used	not used	32.0 mV	15 V

Table 1 - Volts Per Level and Volts Per Division factors for 8-bit and 12-bit digitizers

signal's amplitude is unknown, begin with the Volts readout set to 120V and then decrease the setting as required.

EXAMPLE

Figures 3 - 5: These illustrate the results when the Volts setting is set to 12V. The "noise" at the peaks of the signal were missed because the Volts Per Level is equal to 3.2 mV (Table 1) which is too high to capture the smaller voltage deviations of the "noise."

Figures 6 - 8: The Volts setting was lowered to 6V which, in turn, lowered the Volts Per Level to 1.6 mV (Table 1). Decreasing the Volts setting allows the scope to begin capturing the smaller voltage deviations.

Figures 9 - 11: The Volts setting was further lowered to 3V, providing a Volts Per Level of 800 μ V. The "noise" has been captured for display because the sensitivity is now low enough to capture and record the smaller voltage deviations.

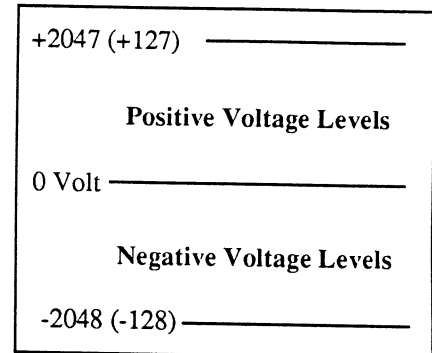

Figure 1 - Voltage Levels for 12-bit digitizer. (Numbers enclosed in parenthesis are for 8-bit digitizers.)

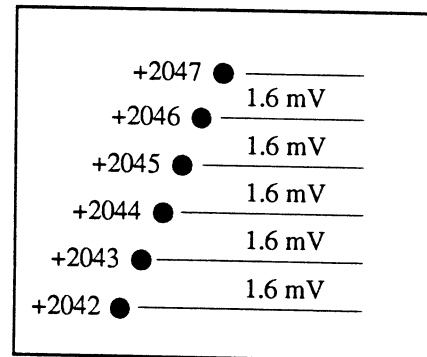

Figure 2 - Detailed view of the 1.6 mV levels when the Volts range is set to 6.0 V on a 12-bit digitizer.



Figure 3: The analog input signal. Note the "noise" on the signal's peaks.

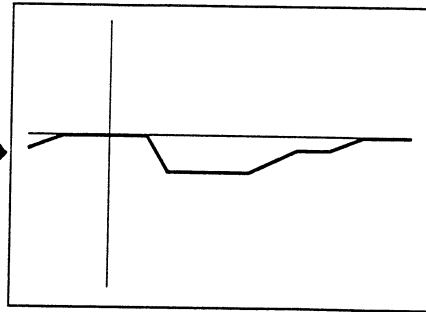

Figure 4: The resulting display captured with the Volts range set to 12V. None of the "noise" has been captured.

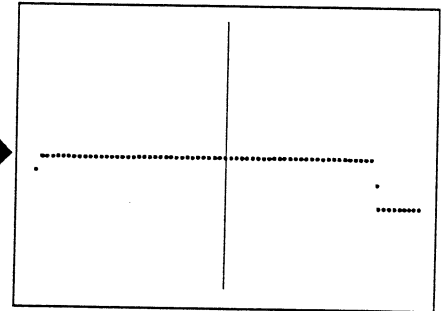

Figure 5: With display expansion applied.



Figure 6: The analog input signal. Note the "noise" on the signal's peaks.

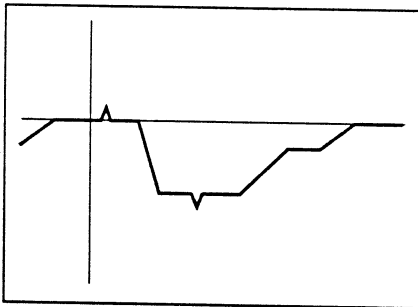

Figure 7: The resulting display after lowering the Volts setting to 6V. The captured signal is beginning to resemble the input signal.

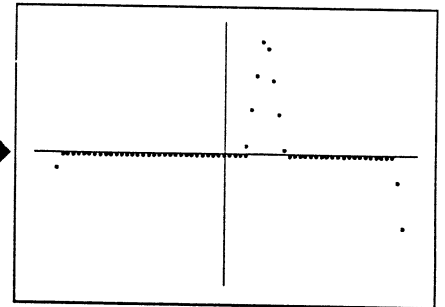

Figure 8: With display expansion applied.

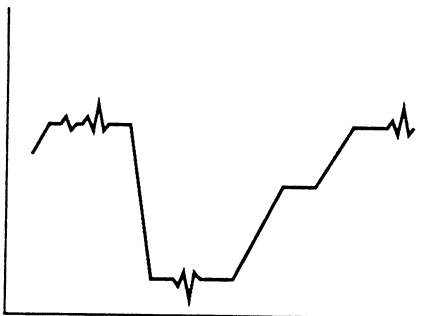

Figure 9: The analog input signal. Note the "noise" on the signal's peaks.

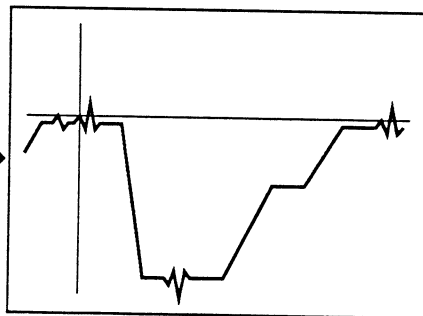

Figure 10: The resulting display lowering the Volts setting to 3V. The captured signal now resembles the input signal.

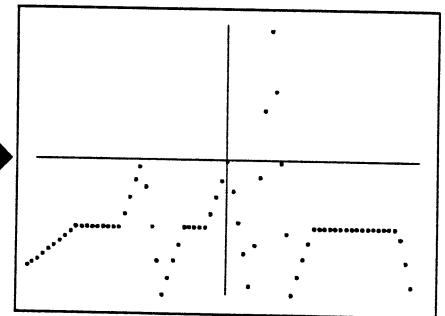

Figure 11: With display expansion applied.

THE POSITION CONTROL

Adjust the channel's Position control to move the channel's waveform vertically on the screen. This allows a signal that has exceeded the vertical display limits of the screen to be brought back into view when in the "Live" mode.

Note: Save Referenced waveforms can be repositioned on the screen using the Position control when the channel is turned off and Save Ref is turned on.

Adjusting the Position control while the Live LED is illuminated adds an analog voltage to the input signal. This is done to extend the range of voltages which can be digitized while maintaining an accurate record of the input signal's absolute voltage values. The digitized analog voltage values are then subtracted from the digitized input signal, thus providing accurate readouts by the voltage numerics.

Figure 1: Note that the top portion of the waveform has been clipped (forced off the screen) because it exceeded the display limits of the screen.

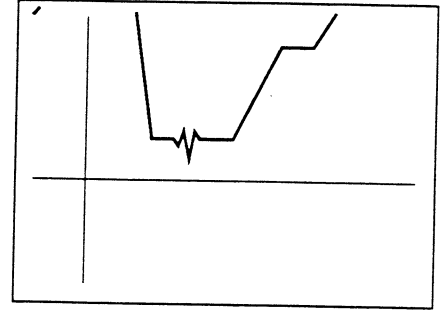

Figure 1

Figure 2: The Position control was adjusted counterclockwise to bring the clipped portion of the waveform back into view.

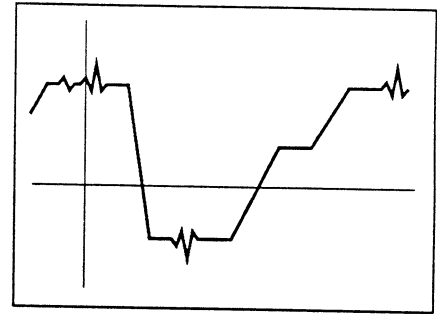
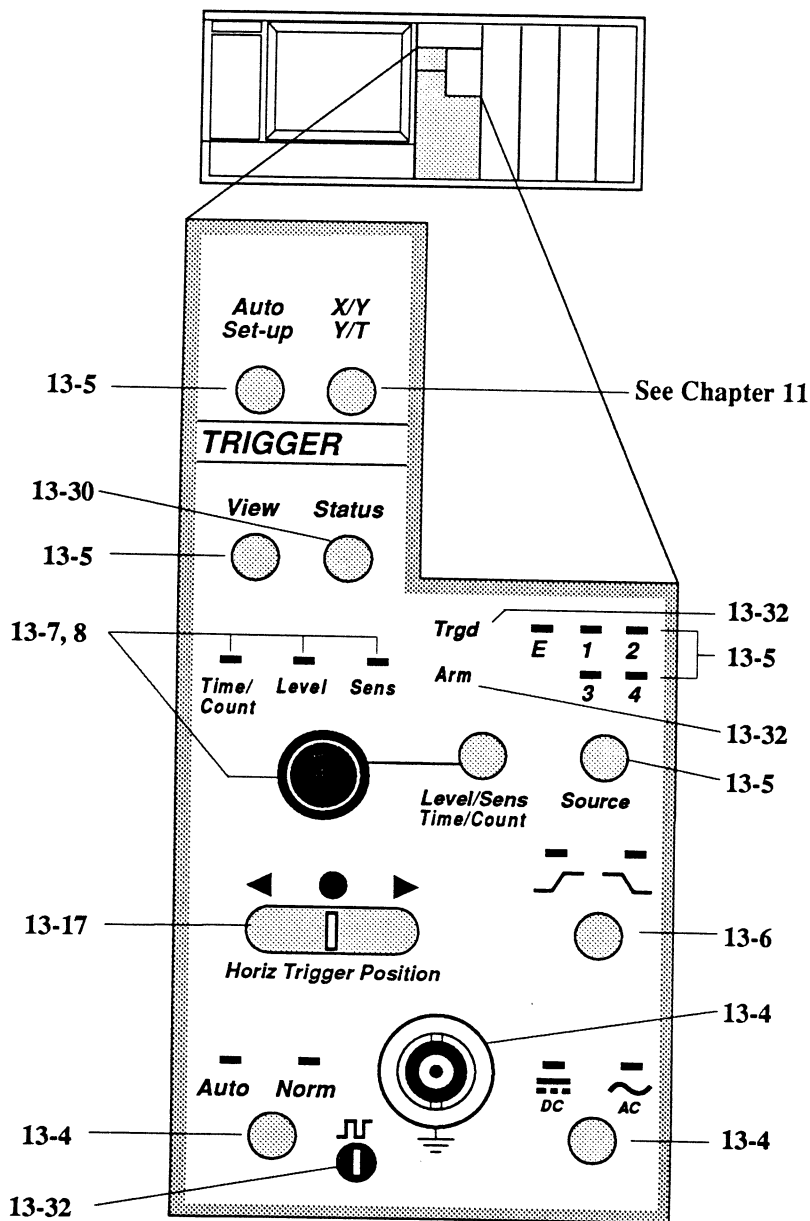

Figure 2

Chapter 13

THE TRIGGER CONTROLS

The table of contents for this chapter is on page 13-2.



This chapter describes the trigger controls. Triggers are used to initiate the sweeps by which the oscilloscope gathers information for display on the screen.

Note: Also see the Trigger Menu in *Chapter 18* for the advanced triggering modes.

Introduction	13-3	Horiz Trigger Position Button	13-17
Auto/Norm Button	13-4	The Various Sweep Modes	13-17
External Trigger Input BNC	13-4	The Trigger Markers	13-18
External Trigger Coupling Button	13-4	• The Data Trigger Marker	13-18
Source Button	13-5	• The Setup Trigger Marker	13-18
View Button	13-5	a. Increasing the Marker's Rate of Movement	13-18
Auto Set-Up Button	13-5	The Trigger Default	13-18
Slope Button	13-6	• Recalling the t=0 Default	13-18
Level Controls	13-7	The Normal Sweep Mode	13-19
Sensitivity Controls	13-8	• Reading Normal Sweep Displays	13-19
Slope, Level and Sensitivity Summaries	13-9	• Reading Time with $\Delta T/\Delta V$ Turned On	13-20
Qualifying Successive Triggers	13-10	The Mid Signal Trigger Mode	13-21
Stabilizing Recurrent Signal Displays	13-12	• Reading Pre-trigger Sweep Displays	13-21
Setting Up Triggers	13-14	• Reading Time with $\Delta T/\Delta V$ Turned On	13-22
(+ or -) Slope Triggers	13-14	• Selecting Mid Signal Triggers in Hold Mode	13-23
Dual Slope Triggers	13-14	• Selecting Mid Signal Triggers in Live Mode	13-24
Single-Shot Triggers	13-15	The Delayed Sweep Mode	13-25
Troubleshooting Trigger Problems	13-16	• Reading Delayed Sweep Displays	13-25
		• Reading Time with $\Delta T/\Delta V$ Turned On	13-26
		• Selecting Delayed Sweeps in Hold Mode	13-27
		• Selecting Delayed Sweep in Live Mode	13-28
		Deriving Triggers from a Single Source	13-29
		Mixing Trigger Times and/or Sweep Modes	13-29
		Status Button	13-30
		Trgd LED	13-32
		Arm LED	13-32
		Compensation Point	13-32

INTRODUCTION

Four basic requirements must be met before a signal can qualify as a valid trigger while in the Normal Trigger mode. Refer to the pages referenced below for descriptions and examples.

Note: Sweeps are triggered automatically by the instrument if it does not receive valid triggers while in the Auto Trigger mode.

1. A signal must be input to the instrument and the trigger Source must be selected accordingly. See page 13-5.
2. The signal's Slope must match the front panel selection (Figure 1). See page 13-6.
3. The signal must begin outside the Sensitivity Window (except for Dual Slope triggering, Figure 6) and completely pass through the window with the proper slope (Figure 2). See page 13-7.
4. The signal must cross the selected trigger Level with the proper slope (Figure 3 illustrates this using positive slope triggering as an example). See page 13-8.

Example

Figures 4 through 6 illustrate successful triggers for positive, negative and dual slope triggers after meeting the Slope, Sensitivity and Level prerequisites.

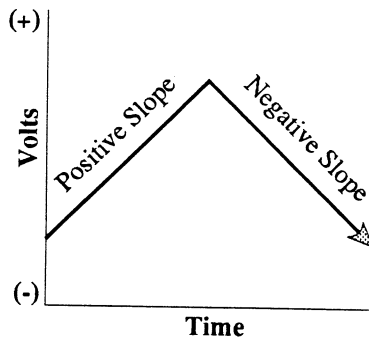

Figure 1 - The slope of the signal must match that as selected on the front panel.

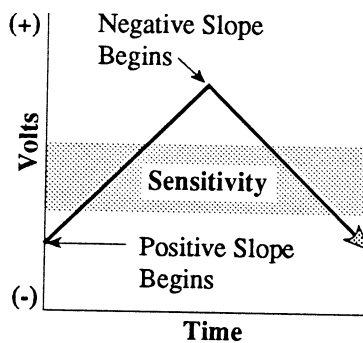

Figure 2 - The signal must begin outside the Sensitivity window.

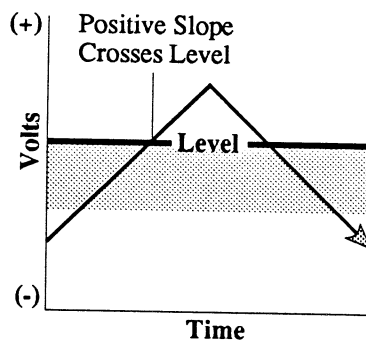

Figure 3 - The signal must pass through the entire Sensitivity window and cross the threshold Level.

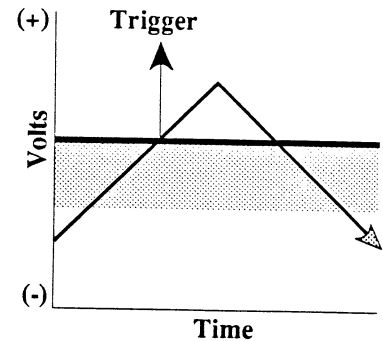

Figure 4 - The signal qualifies as a positive trigger.

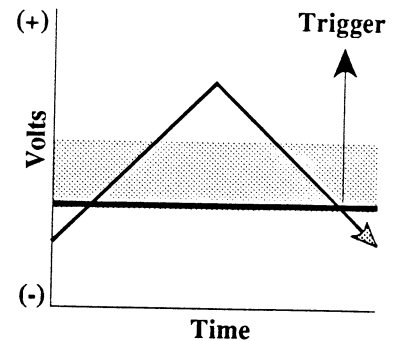

Figure 5 - The signal qualifies as a negative trigger.

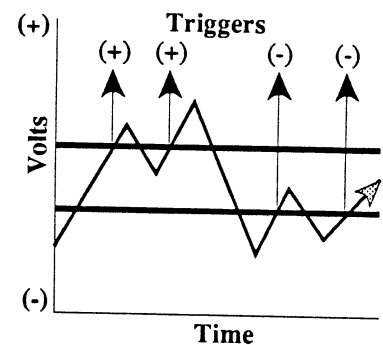

Figure 6 - The signal qualified as dual slope triggers at the points shown. Dual Slope triggering ignores the Sensitivity window. Only the Source, Slope and Level requirements have to be met.

AUTO/NORM TRIGGER BUTTON

Press the trigger Auto/Norm button to select whether sweeps will be triggered automatically by the scope if a valid trigger is not received (Auto Mode) or only when a valid trigger is received (Normal Mode).

The **Trgd LED** (located above the trigger Level/Sens button) lights throughout the duration of each sweep.

Auto Trigger Mode

The Auto Trigger mode is selected when the Auto LED is on.

Sweeps are triggered automatically if the input signal does not qualify as a valid trigger between sweeps.

Normal Trigger Mode

The Normal Trigger mode is selected when the Norm LED is on.

Sweeps are triggered only when a signal input to an ungrounded input BNC meets the trigger Source, Slope, and Level requirements. These requirements are described on the following pages.

EXTERNAL TRIGGER INPUT BNC

Signals input to the External input BNC will trigger sweeps on the channel(s) that are turned on if -

- The external input BNC is selected as the trigger source. See Source Button on the next page.
- The Live mode is armed (Live LED on).
- The signal satisfies the trigger slope and sensitivity requirements described later in this chapter.

Note: Using the External input BNC to input the triggering signal frees the acquisition channels to capture signals of interest for display.

Signals input to the External input BNC must have a peak-to-peak amplitude of at least 200 mV to qualify as a valid trigger.

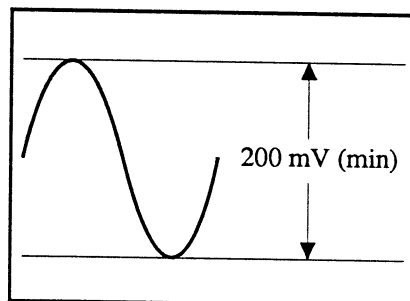

Figure 1 - Minimum peak-to-peak amplitude requirements for the External input BNC.

EXTERNAL TRIGGER COUPLING BUTTON

Press the DC/AC coupling button to select whether only AC signals or AC signals with DC components will be coupled to the trigger detection circuit via the External input BNC.

DC Coupling

External AC and DC components of the signal are input to the trigger detection circuit.

AC Coupling

DC components and AC signals of approximately 10 Hertz or less are **blocked** from entering the trigger detection circuit.

TRIGGER SOURCE BUTTON

Press the trigger Source button until the desired LED (1, 2, 3, 4, or E) lights accordingly for the input BNC being used to input the triggering signal.

- 1 = Channel 1
- 2 = Channel 2
- 3 = Channel 3
- 4 = Channel 4
- E = External input BNC

Amplitude Requirements

The amplitude of the triggering signal must be at least one digitizer level to qualify as a valid trigger when input to any of the channel input BNCs. This is so sensitive that virtually any signal input to one of the channels can be used to trigger a sweep when the trigger sensitivity and level are set properly.

Note: If the amplitude of the signal input to the External input BNC is not large enough to qualify it as a valid trigger, input the signal to one of the channels and select that channel as the trigger source.

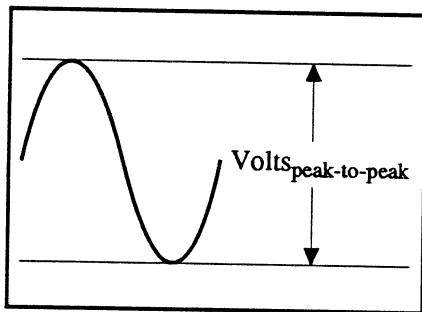

Figure 1 - Voltage Amplitude

TRIGGER VIEW BUTTON

Press the trigger View button to view the current trigger waveform and the Level/Sensitivity values (Figure 2). This allows you to select specific values that will allow the signal to qualify as a valid trigger. See the Level and Sensitivity Control descriptions on the following pages.

Note: Either TRG or ARM is displayed in the lower left corner of the screen if an Advanced Trigger mode is enabled (Figure 2). See *Chapter 18*.

The View Mode allows you to quickly view events leading up to a trigger. E.g., assume you are capturing data in the Normal Sweep mode and want to view events leading up to the trigger:

1. Press the View button. The first 20% of the screen displays pre-trigger data to the left of the Trigger Marker (Figure 2). The other 80% of the screen displays post-trigger data to the right of the Trigger Marker. Use the Horiz Trigger Position button to select the amount of pre-trigger data. You can also alter the trigger Level and Sensitivity settings and read their actual values on the screen.
2. Press the View button again to return to the Normal Sweep mode.

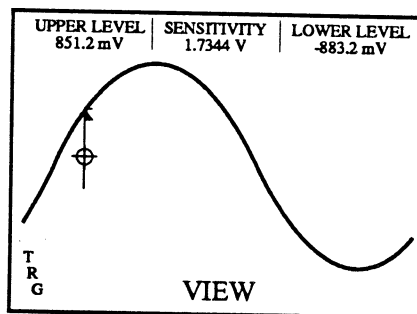

Figure 2 - View appears on the screen when the View mode is turned on.

TRIGGER AUTO SET-UP BUTTON

Press the Auto Set-Up button to automatically set various control values such that a repetitive input signal greater than 10 Hz and 30 mVpp will qualify as a valid trigger.

Note: Pressing the Auto Set-Up button automatically places the instrument into the Live Mode.

The instrument essentially analyzes the signal and determines:

- a. The minimum Volts setting that will display the signal without exceeding the display limits or without overlapping waveforms captured by other channels.
- b. The Position setting that will display the waveform centered vertically on the screen or positioned to share the screen with other waveforms captured by other channels.
- c. The optimum trigger Level value and trigger Sensitivity value that will allow the signal to qualify as a valid trigger.
- d. The Time setting that will allow four to five cycles of the signal to be captured.

Note: The Auto Set-Up button is a single-shot function. It must be pressed each time the Auto Set-Up feature is to be activated.

Once the signal has qualified as a valid trigger, the Volts, Position, trigger Level and trigger Sensitivity and Time controls can be altered as desired to obtain specific results on the screen. See the Level Control and Sensitivity Control descriptions on the following pages for additional information.

TRIGGER SLOPE BUTTON

Press the Slope button until the desired trigger slope LED lights to select either negative, positive, or dual slope triggering.

The selected Slope is identified on the screen by the slope marker (Figure 1) located at the left edge of the screen.

The front panel LEDs above the Slope button also indicate the selected slope:

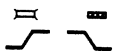
 = Positive Slope Trigger
Only increasing voltages qualify as valid triggers (Figure 2).

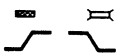
 = Negative Slope Trigger
Only decreasing voltages qualify as valid triggers (Figure 3).

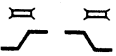
 = Dual Slope Trigger
Both increasing and decreasing voltages qualify as valid triggers when dual slope is selected (Figure 4).

Note: The signal must also meet the Threshold Level (page 13-7) and Sensitivity (page 13-8) requirements to qualify as a valid trigger.

Note: An unstable display will occur during Dual Slope triggering if sweeps are triggered alternately between positive and negative slopes on repetitive waveforms.

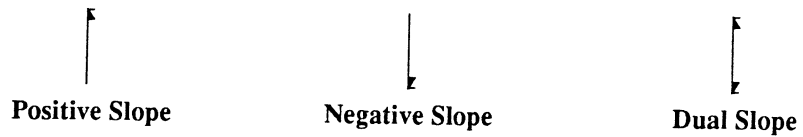

Figure 1 - Trigger Slope Markers appear when View Mode is turned on.

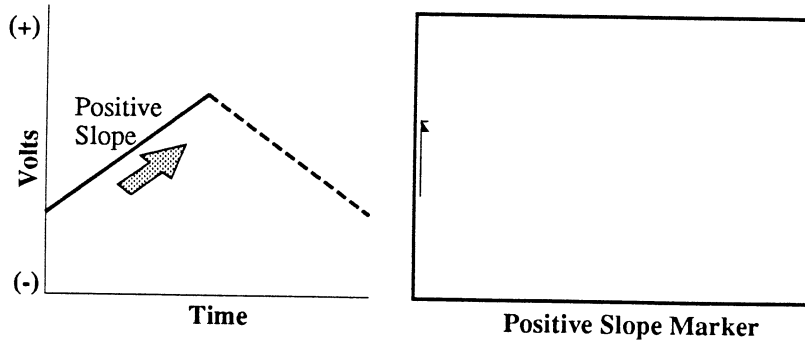

Figure 2 - Positive Slope = Increasing Voltages

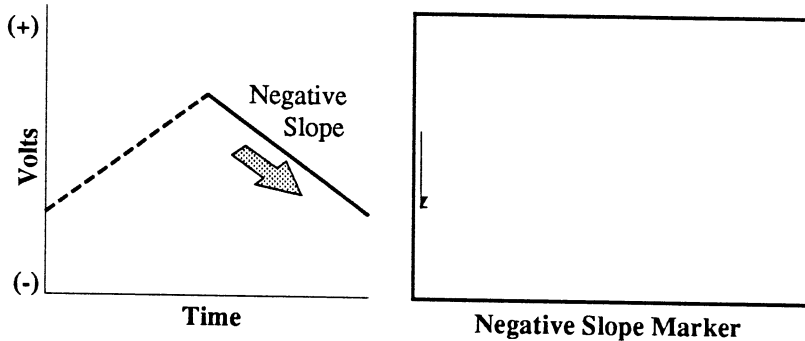

Figure 3 - Negative Slope = Decreasing Voltages

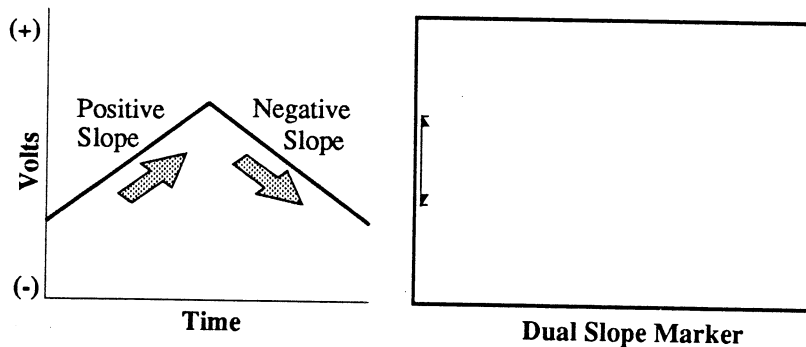

Figure 4 - Dual Slope = Increasing or Decreasing Voltages

TRIGGER LEVEL CONTROL

Press the Level/Sens button until the Level LED lights.

The trigger Level is represented by the small horizontal line at the tip of the trigger Slope marker (Figure 1).

The signal must cross the trigger Level to qualify as a valid trigger. Adjust the Level/Sens control clockwise to raise the trigger Level and counterclockwise to lower it.

Note: The signal must also meet the Slope (page 13-6) and Sensitivity (page 13-8) requirements to qualify as a valid trigger.

Note: To view the actual Upper Level and Lower Level voltage values while adjusting the Level setting, turn on the View mode. See page 13-5, View Button.

Example

Assume positive slope triggering.

Figure 2: The trigger Level was set too high. The signal will never qualify as a valid trigger because it cannot cross the trigger Level.

Figure 3: The trigger Level was lowered, allowing the signal to qualify as a valid trigger because now it can cross the trigger Level.

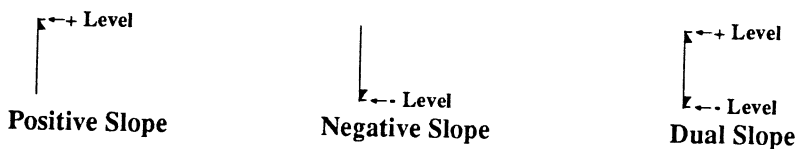

Figure 1 - Trigger Level Markers

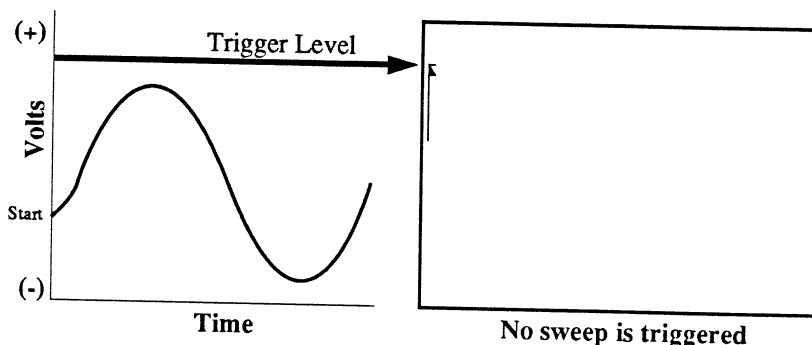

Figure 2 - The signal fails to qualify as a valid trigger because the trigger Level is set too high, thus preventing the signal from crossing the trigger level.

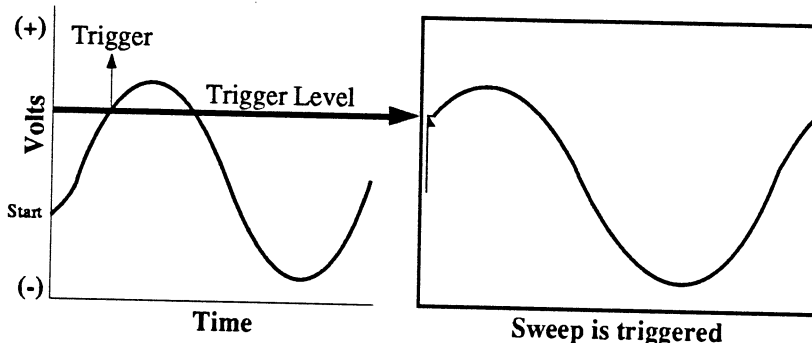

Figure 3 - The trigger Level was lowered, allowing the signal to qualify as a trigger.

SENSITIVITY CONTROL

Press the Level/Sens button until the Sens LED lights. The Level/Sens control can now be used to help eliminate false triggering due to noise. The distance between the top and bottom of the Slope marker represents the trigger Sensitivity window (see Figure 1).

Note: Dual Slope triggering does not use Sensitivity to qualify triggers.

For positive or negative slope triggering, the signal must begin outside the Sensitivity window with the proper slope to qualify as a valid trigger. Adjust the Level/Sens control clockwise to increase the Sensitivity window and counterclockwise to decrease the window. The sensitivity range is adjustable from 2% to 98% of the Volts setting. 0% corresponds to the current trigger Level setting.

Note: The signal must also meet Slope (page 13-6) and Level (page 13-7) requirements to qualify as a valid trigger.

Note: To view the actual Sensitivity voltage value while adjusting the Sensitivity setting, turn on the View mode. See page 13-5, View Button.

Example

Assume positive slope triggering.

Figure 2: The signal will never qualify as a valid trigger because the Sensitivity window is set too wide, preventing the signal from starting outside the sensitivity window.

Figure 3: The Sensitivity window was decreased. The signal now qualifies as a valid trigger because the positive slope begins outside the window.

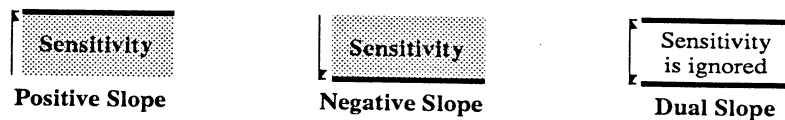

Figure 1 - Trigger Sensitivity Indicators appear when View Mode is turned on.

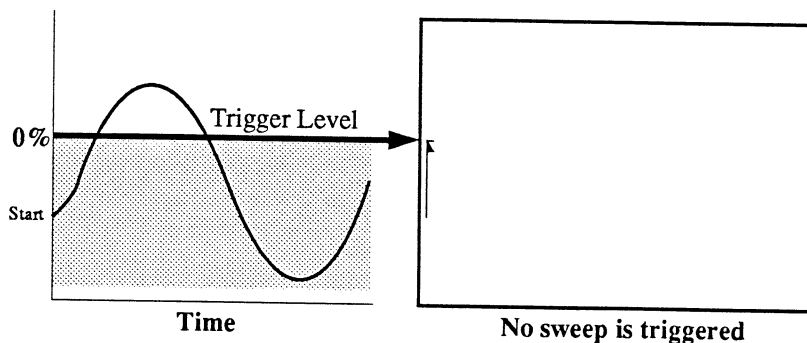

Figure 2 - This signal failed to trigger a sweep because it did not begin its initial positive voltage transition outside the Sensitivity window.

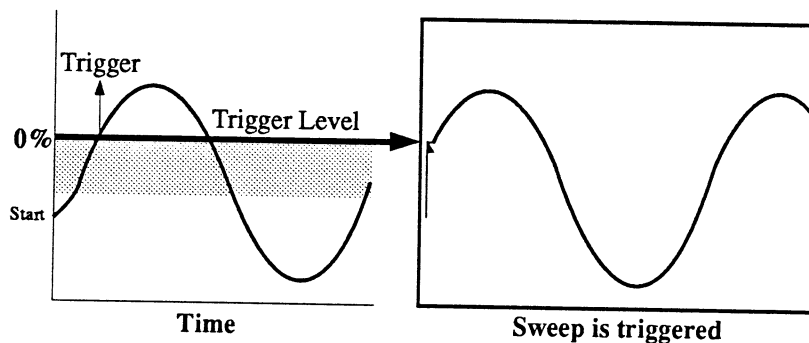
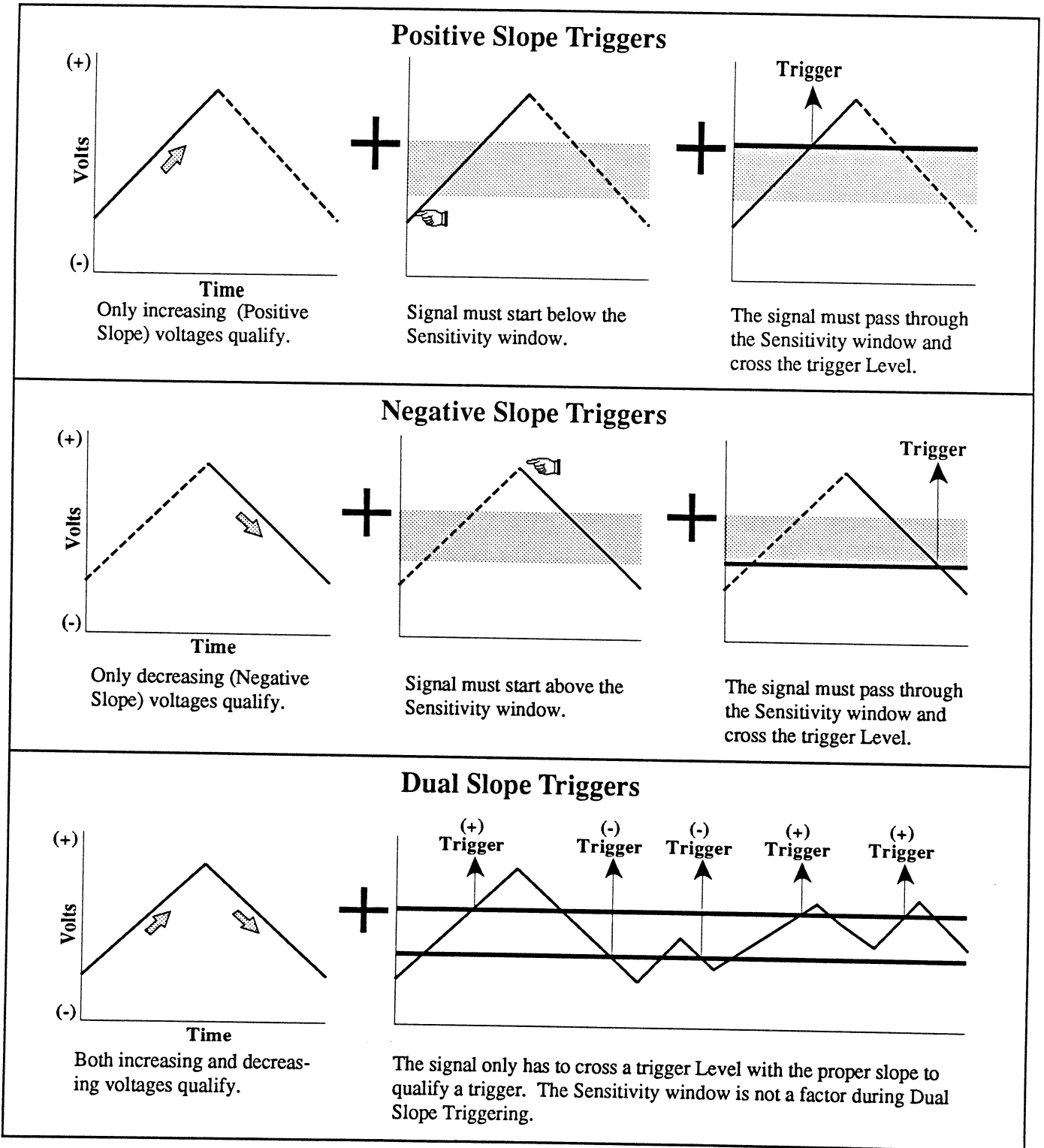

Figure 3 - The Sensitivity window was reduced. The signal qualified as a valid trigger because it started its positive voltage transition outside the Sensitivity window before it crossed the Trigger Level.

SLOPE, LEVEL AND SENSITIVITY SUMMARIES



QUALIFYING SUCCESSIVE TRIGGERS

Note: Review *pages 13-5 through 13-9*.

The basic rule that determines whether or not a signal will qualify initially as a valid trigger is illustrated by the three examples in Figure 1 on the next page.

Figure 1A illustrates that the signal qualified initially because it started its positive slope below the sensitivity window.

Figures 1B and 1C illustrate the basic path that the signal must follow to trigger the next sweep.

Note: Of course, a new sweep cannot be triggered if a sweep is already in progress. However, the first valid trigger to occur after the current sweep is completed will trigger the next sweep.

Figures 2A through 2C on the next page illustrates how the signal would fail to trigger a second sweep even though it crosses the trigger level a second time in Figure 2C.

As described on the previous pages, the signal must cross the trigger Level to become a potential trigger. However, crossing the trigger Level with the proper slope has no meaning unless the signal begins initially outside of the Sensitivity window before it finally crosses the trigger level with the proper slope as shown in Figure 2D.

Note: Sensitivity is ignored when Dual Slope triggering is selected. The signal only has to meet the Source, Slope and trigger Level requirements to qualify as a valid trigger.

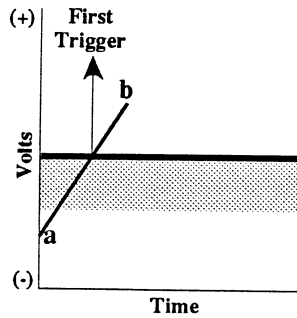

1A

To trigger the first sweep, the signal must

1. begin its positive slope transition below the Sensitivity window (a) and
2. cross the trigger Level (a - b).

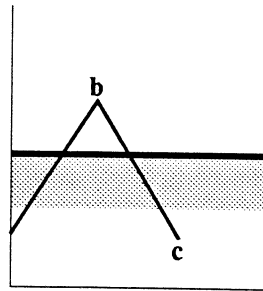

1B

To trigger the next sweep, the signal must

1. reverse direction (slope),
2. cross the trigger Level
3. pass through the entire Sensitivity window (b - c) ...

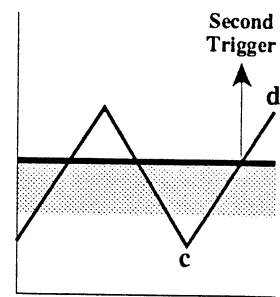

1C

4. reverse direction again,
5. pass through the Sensitivity window
6. and recross the trigger Level (c - d).

Figure 1 - Example of the basic signal flow successfully permits successive triggering using Positive Slope triggering.

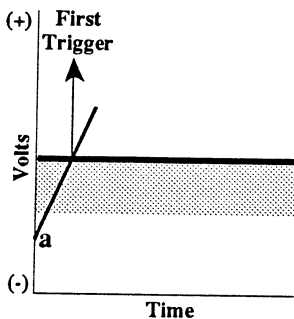

2A

The signal properly begins its positive slope transition below the Sensitivity window, passes through the window and crosses the trigger Level (a - b), thus triggering the first sweep.

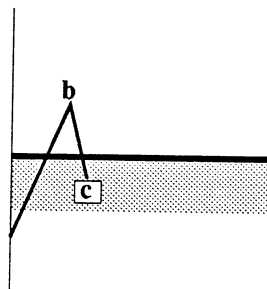

2B

It then reversed direction, crossed the trigger Level and entered the Sensitivity window (b - c). This time however, rather than passing through the entire Sensitivity window before changing direction,

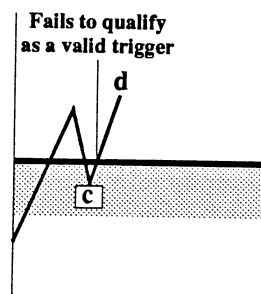

2C

it reversed direction too soon. The signal did not qualify as a valid trigger because it did not drop below the sensitivity window before beginning its second positive slope transition (c - d).

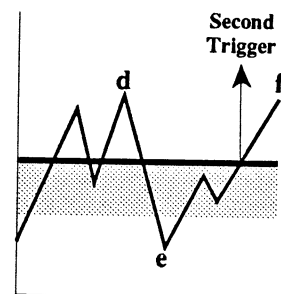

2D

The signal path (d - e - f) allowed the signal to qualify a second trigger because it once again began below the window and finally crossed the trigger threshold.

Figure 2 - Example of sequence that fails to requalify the signal as a valid trigger using Positive Slope triggering.

STABILIZING RECURRENT SIG- NAL DISPLAYS

There may be times when the display becomes unstable while trying to capture recurrent signals in the Live mode. This is caused by triggering sweeps at a nonperiodic rate from different features of the signal.

Remember the basic rule of triggering: **The first valid trigger to occur after a sweep ends will trigger the next sweep.**

Figure 1 defines Features A and B which are referenced in Figures 2 through 4 on the next page.

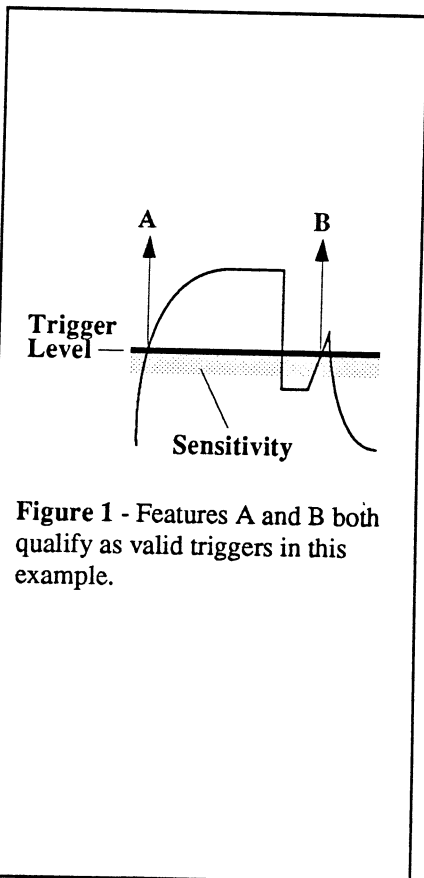

Figure 1 - Features A and B both qualify as valid triggers in this example.

Example

In Figure 2 on the next page, note that sweeps are triggered alternately between Features A and Feature B. This will cause an unstable display as the instrument alternates between the signal features captured during the Feature A sweeps and the Feature B sweeps.

The following two solutions illustrate methods that can be used to stabilize the display by eliminating Feature B as a valid trigger.

Solution #1

Figure 3: The Sensitivity window was widened by adjusting the Sensitivity control until the positive slope transition of Feature B always begins inside the window. Now each of the displays contain identical waveform data, thus producing a stable display from sweep to sweep.

Remember, for positive slope triggering, the signal transition must start below the window.

Solution #2

Figure 4: The trigger Level (dark line) was raised by adjusting the Level control until Feature B could no longer cross the trigger Level. Now each of the sweeps contain identical waveform data, thus producing a stable display from sweep to sweep.

Remember, the signal must cross the trigger Level to qualify as a valid trigger with the proper slope to qualify as a valid trigger.

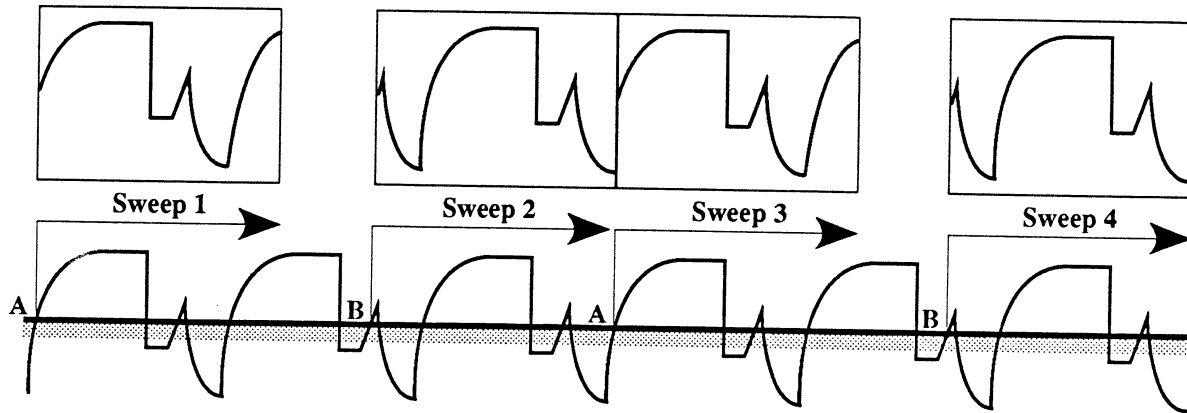

Figure 2: Example of an unstable display caused by nonperiodic triggering off of Features A and B.

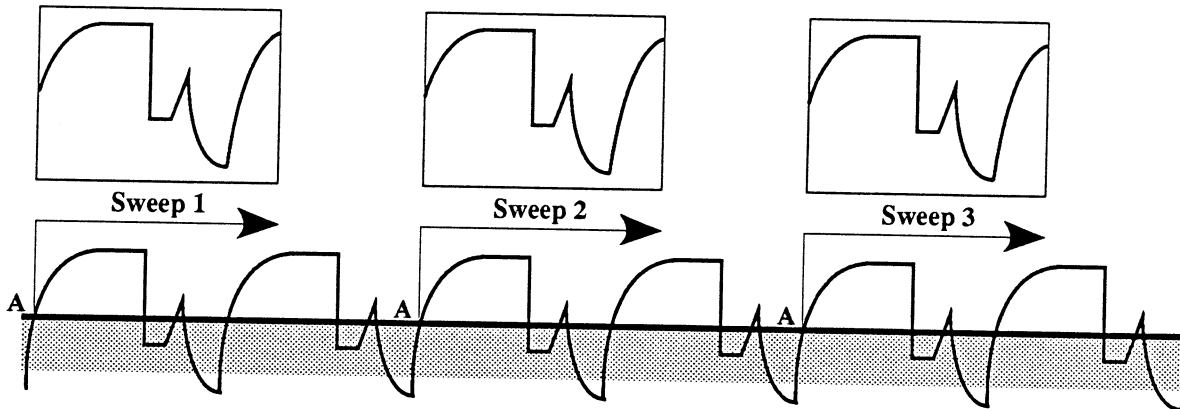

Figure 3 - Solution #1: Eliminating Feature B by widening the trigger Sensitivity window below the Feature B transition.

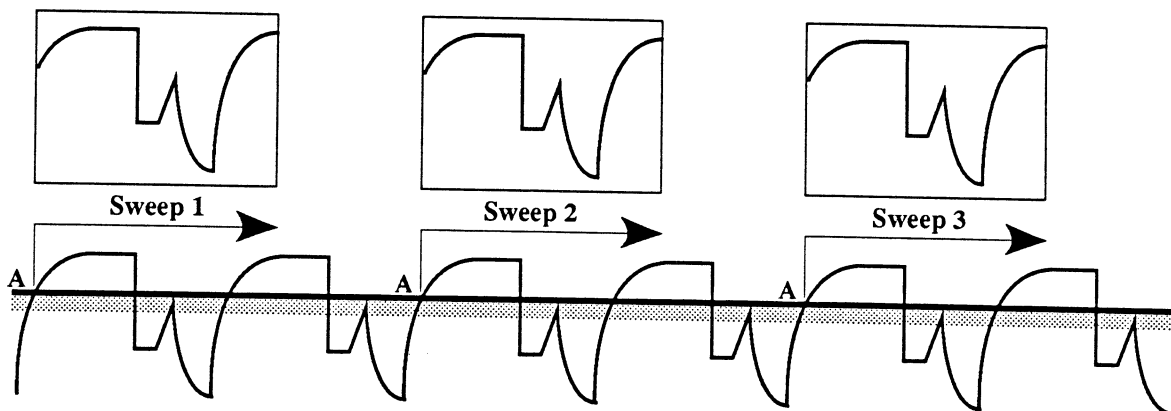

Figure 4 - Solution #2: Eliminating Feature B by raising the trigger Level above Feature B.

SETTING A (+/-) SLOPE TRIGGER

1. Select the desired trigger source.
2. Select Positive or Negative slope triggering as desired.
3. Select the desired signal Coupling.
4. Turn on the View mode if desired.
5. Press the Live button.
6. Adjust the Position control for the best trace placement on the screen.
7. Select the Volts setting as required.
8. Press the Level/Sens button until the Sens LED lights and then adjust the Level/Sens control until the "window" exceeds any "noise" on the signal.
9. Press the Level/Sens button until the Level LED lights and then adjust the Level/Sens control until the trigger Level intersects the desired trigger point on the signal.
10. Fine tune the trigger Level and Sensitivity window as required.
11. Turn off the View mode if it was turned on in step 4.

SETTING A DUAL SLOPE TRIGGER

1. Select the desired trigger source.
2. Select Dual slope triggering.
3. Select the desired signal Coupling.
4. Turn on the View mode if desired.
5. Press the Live button.
6. Adjust the Position control for the best trace placement on the screen.
7. Select the Volts setting as required.
8. Press the Level/Sens button until the Sens LED lights and then adjust the Level/Sens control for maximum sensitivity.
9. Press the Level/Sens button until the Level LED lights and then adjust the Level/Sens control until the trigger Levels are centered between the desired positive and negative trigger points.
10. Press the Level/Sens button until the Sens LED lights and then adjust the Level/Sens control until the trigger Levels intersect the desired trigger points on the signal.
11. Fine tune the trigger Level and Sensitivity window as required.
12. Turn off the View mode if it was turned on in step 4.

Note: It sometimes can be difficult to determine if sweeps are actually being triggered when either the Time setting is set for very slow sweeps or you have selected very large sweep lengths.

If this situation is present, observe the Trgd and Arm LEDs. The Arm LED turns on when the scope has been armed to acknowledge a valid trigger. When a valid trigger is received and a sweep is triggered, the Trgd LED turns on. At the completion of the sweep, both the Arm and Trgd LEDs turn off.

SETTING A SINGLE-SHOT SIGNAL

When the signal occurs only once, it is important to know the signal's characteristics in advance and adjust the threshold level and sensitivity accordingly:

If possible, simulate the triggering signal, either from a signal generator or directly from an external trigger source.

1. Set the Time to 10 μ S or faster.
2. Ground the inputs.

3. Turn on the View mode if desired.
4. Press the Live button.
5. Turn on Autocenter.
6. Select Auto triggering.
7. Adjust the channel's Position control until the trace is positioned as desired on the screen.
8. Select Normal triggering.
9. Press the Level/Sens button until the Sens LED lights and then adjust the Sens/Level control fully clockwise.
10. Press the Level/Sens button until the Level LED lights and then slowly adjust the Level/Sens control until the Trgd LED flashes.
11. Turn Autocenter off.
12. Select the Time as required.
13. Unground the input BNC being used to input the triggering signal.
14. Turn the View mode off if it was turned on in step 3.
15. Press the LIVE button.
16. Press the HOLD NEXT button. The scope is now armed to capture the signal when the next valid trigger is received.

TROUBLESHOOTING TRIGGER PROBLEMS

Arm LED does not light

Hint: If you are using one of the advanced triggering modes (Chapter 18) the qualifying trigger to start the timer/counter has not been received.

Hint: If you are using the Mid Signal Trigger mode (pretrigger mode) with a very long sweep time, the buffer memory may not have filled yet.

Hint: Use the Auto Trigger Mode (page 13-4) to see what trigger condition is not being satisfied.

Ensure that:

1. The Live Mode is armed, Live LED illuminated.
2. The trigger source corresponds with the triggering signal's source:
 - 1 = Channel 1 input BNC
 - 2 = Channel 2 input BNC
 - 3 = Channel 3 input BNC
 - 4 = Channel 4 input BNC
 - E = External input BNC
3. The input BNC receiving the triggering signal is not grounded.
4. The Volts setting is set for a range acceptable for the signal's maximum peak-to-peak amplitude.
5. The trigger Level is not set too high, preventing the signal from crossing the trigger Level.
6. The Sensitivity window is not set too wide, preventing the signal from beginning below (positive slope) or above (negative slope) the window before it begins its initial voltage transition.
7. A triggering signal is actually being input to the instrument.

Arm LED lights but Trgd LED does not light

Hint: Use the Auto Trigger Mode (page 13-4) to see what trigger condition is not being satisfied.

Ensure that:

1. The Live Mode is armed, Live LED illuminated.
2. The trigger source corresponds with the triggering signal's source:
 - 1 = Channel 1 input BNC
 - 2 = Channel 2 input BNC
 - 3 = Channel 3 input BNC
 - 4 = Channel 4 input BNC
 - E = External input BNC
3. The input BNC receiving the triggering signal is not grounded.
4. The Volts setting is set for a range acceptable for the signal's maximum peak-to-peak amplitude.
5. The trigger Level is not set too high, preventing the signal from crossing the trigger Level.
6. The Sensitivity window is not set too wide, preventing the signal from beginning below (positive slope) or above (negative slope) the window before it begins its initial voltage transition.
7. A triggering signal is actually being input to the instrument.

Trgd and Arm LED light but no new data appears

If the Trgd and Arm LEDs illuminate, but the scope still does not display any new data:

1. Ensure that an input signal is input to at least one of the channels.
2. The rate of update may be so slow that you may not notice that data is actually being captured. The display update rate depends upon the selected Time and Sweep Length settings. To approximate the display update rate -

$$\frac{\text{Sweep length} \times \text{Time setting}}{1000}$$

HORIZ TRIGGER POSITION BUTTON

Use the Horiz Trigger Position button (Figure 1) to select Normal, Mid Signal Trigger or Delayed sweep displays (Figure 2).

Note: You can control the rate of movement of the Setup Trigger Marker in the same manner as when using the Cursor buttons to move the cursors. See "Increasing the Setup Trigger Marker's Rate of Movement" on the next page. Also, you can set each channel independently for different triggering displays. See *Chapter 18, Independent Delays*.

Normal Sweep (Page 13-19)

The trigger time ($t=0$) coordinate is located at the extreme left edge of the display screen. Only post-trigger data following a valid trigger is captured for display.

Mid Signal Trigger (Page 13-21)

The trigger time ($t=0$) coordinate can be located anywhere on the screen. This mode allows you to see the events leading up to the trigger (pre-trigger data) as well as the events following the trigger (post-trigger data).

Delayed Sweep (Page 13-25)

The trigger time ($t=0$) coordinate is located off the left edge of the screen. A valid trigger received by the scope initiates a user-selectable time delay which must elapse before the actual sweep will begin.

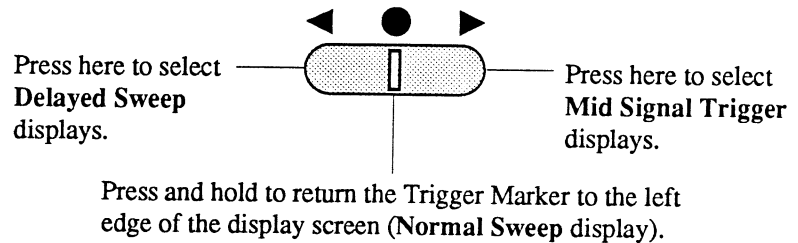

Figure 1 - Horiz Trigger Position Button

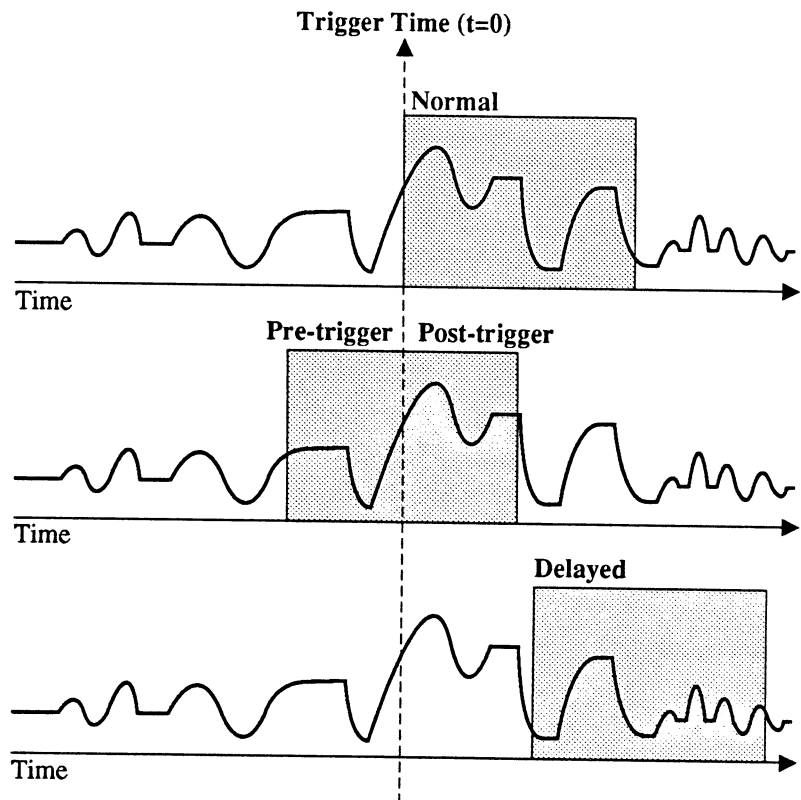

Figure 2 - Examples of displays according to sweep mode selected.

THE TRIGGER MARKERS

The scope uses two trigger markers, Data Trigger and Setup Trigger. Their functions are discussed in more detail on pages 13-19 through 13-23.

The Data Trigger Marker

The Data Trigger Marker (Figure 1) identifies the trigger time ($t=0$) for the waveform that was captured during the last sweep while in the Normal Sweep or Mid Signal Trigger Sweep modes.

Note: The Data Trigger Marker is replaced with a left pointing arrow when you are operating the instrument in the Delayed Sweep mode. See page 13-25.

The Setup Trigger Marker

The Setup Trigger Marker (Figure 2) appears when a new Mid Signal Trigger ($t=0$) is being selected while in the Hold Last mode. Once the sweep is triggered, it will be replaced with the Data Trigger Marker.

Increasing the Setup Trigger Marker's Rate of Movement

To increase the rate of movement of the Setup Trigger Marker while selecting Mid Signal Trigger or Delayed Sweeps modes:

1. Press and hold in the Horiz Trigger Position button.
2. Release the button and immediately press and hold it in again.
3. To move to the next higher rate of movement, repeat step 2 until the desired rate of movement is achieved or the maximum rate of movement has been reached.

To return to the slow rate, release the button for approximately one second and then press it again.

The $t=0$ Trigger Default

To quickly reset the trigger time $t=0$ to the left edge of the screen (Normal Trigger Mode) while in the Mid Signal Trigger or Delayed Sweep modes, press the center of the Horiz Trigger Position button. The Data Trigger Marker (Figure 1) will reappear at the left edge of the display screen, the Normal Trigger mode location.

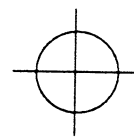

Figure 1 - The Data Trigger Marker identifies the $t=0$ and $v=0$ coordinates of the last sweep.

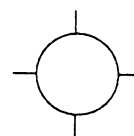

Figure 2 - The Setup Trigger Marker locates the user-selected trigger time $t=0$ and $v=0$ coordinates that will be used during the next Mid Signal Trigger sweep.

NORMAL SWEEP MODE

The trigger time ($t=0$) coordinate is located at the extreme left edge of the display screen when data is being captured the scope is capturing data in the Normal Sweep mode. Only events that occur after a valid trigger is received are captured for display on the screen (Figure 1).

Note: The scope defaults to the Normal Sweep Mode upon the initial application of power to the instrument.

Reading Normal Sweep Displays

The Data Trigger Marker locates the $t=0$ coordinate which is at the extreme left edge of the screen unless the Reset Numerics function is turned on (see the next page).

Moving the vertical cursor toward the right edge of the screen will cause the time numerics to increment in steps determined by the Time setting.

Also see the next page when employing the $\Delta T/\Delta V$ (Reset Numerics) feature.

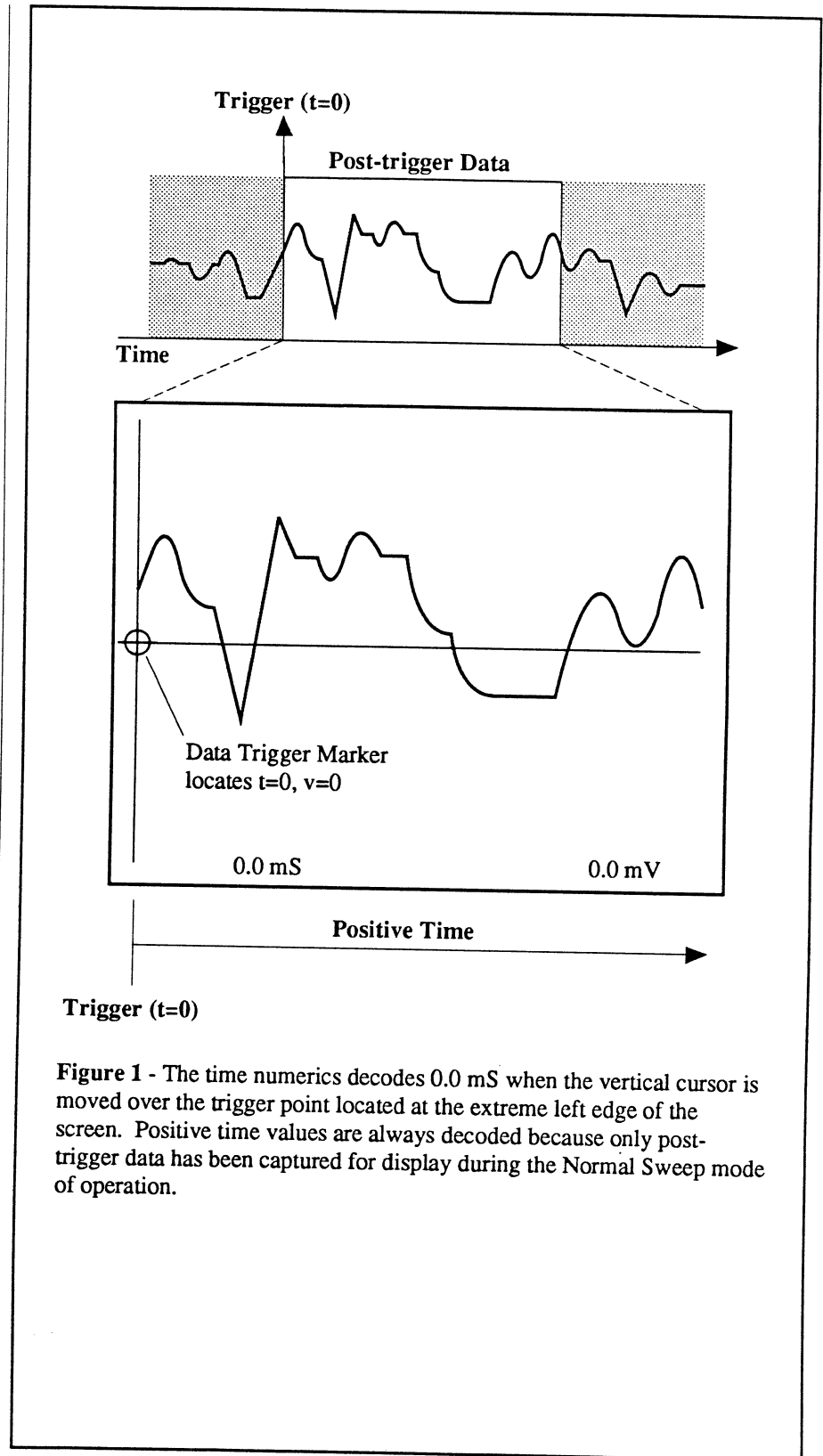

Figure 1 - The time numerics decodes 0.0 mS when the vertical cursor is moved over the trigger point located at the extreme left edge of the screen. Positive time values are always decoded because only post-trigger data has been captured for display during the Normal Sweep mode of operation.

Reading Time on Normal Sweep Displays with $\Delta T/\Delta V$ Turned On

The $\Delta T/\Delta V$ button (Reset Numerics) allows you to select a new $t=0$ coordinate which can be used to read comparative time measurements between any two points on the screen directly off the Time Numerics (refer to *Chapter 9, $\Delta T/\Delta V$ Button*).

The time numerics will now decode time with respect to the new $t=0$ origin (identified with a small crosshair) rather than at the position of the Data Trigger Marker.

The Data Trigger Marker will remain fixed at its current position.

Example

Figure 2: A Normal Sweep signal was captured and the $\Delta T=0/\Delta V=0$ coordinates were set at the position of the crosshair.

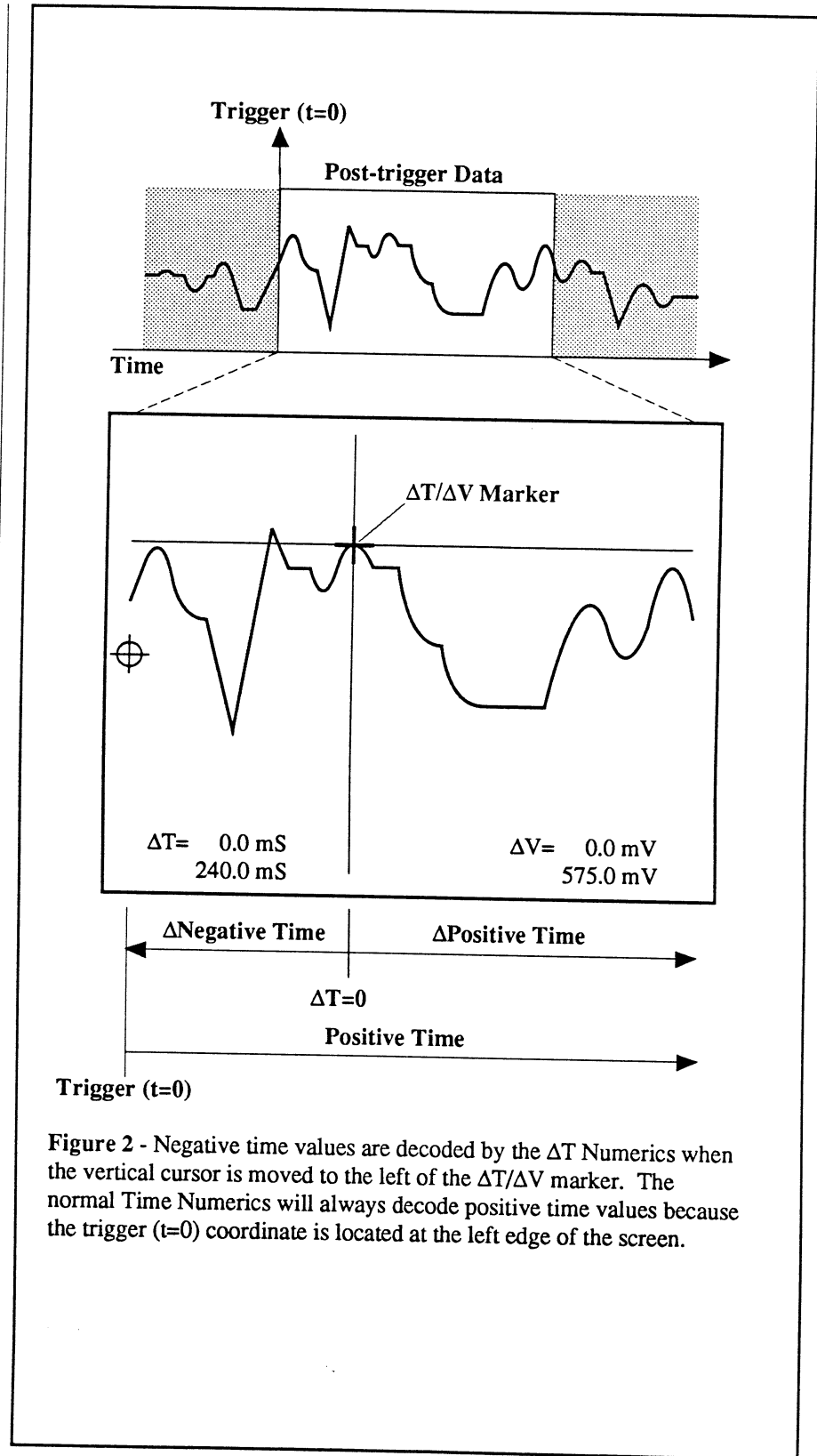

Figure 2 - Negative time values are decoded by the ΔT Numerics when the vertical cursor is moved to the left of the $\Delta T/\Delta V$ marker. The normal Time Numerics will always decode positive time values because the trigger ($t=0$) coordinate is located at the left edge of the screen.

MID SIGNAL TRIGGER SWEEP MODE

The trigger time ($t=0$) coordinate can be located anywhere between the left and right edges of the screen to capture pre-trigger and post-trigger data for display. Pre-trigger data, as the name implies, are events that occur before the sweep is triggered. Likewise, post-trigger data are events that occur after the sweep is triggered. See Figure 1.

Note: The Arm LED will not turn on until the Mid Signal Trigger buffer memory has been filled. The delay caused during this time will be more evident when Mid Signal triggering is combined with very long sweep times.

Note: The instrument defaults to the Normal Sweep Mode upon the initial application of power.

Reading Pre-trigger Sweep Displays

The Data Trigger Marker always locates the trigger time ($t=0$) coordinate if the $\Delta T/\Delta V$ mode is turned off (see the next page).

Data to the left of the marker is pre-trigger data and the time numerics are prefixed with a negative sign when the vertical cursor is in the pre-trigger portion of the screen.

Data to the right of the marker is post-trigger data and positive values are decoded when the vertical cursor is in the post-trigger data portion of the screen.

Example

Figure 1: This illustrates a typical Mid Signal Trigger display.

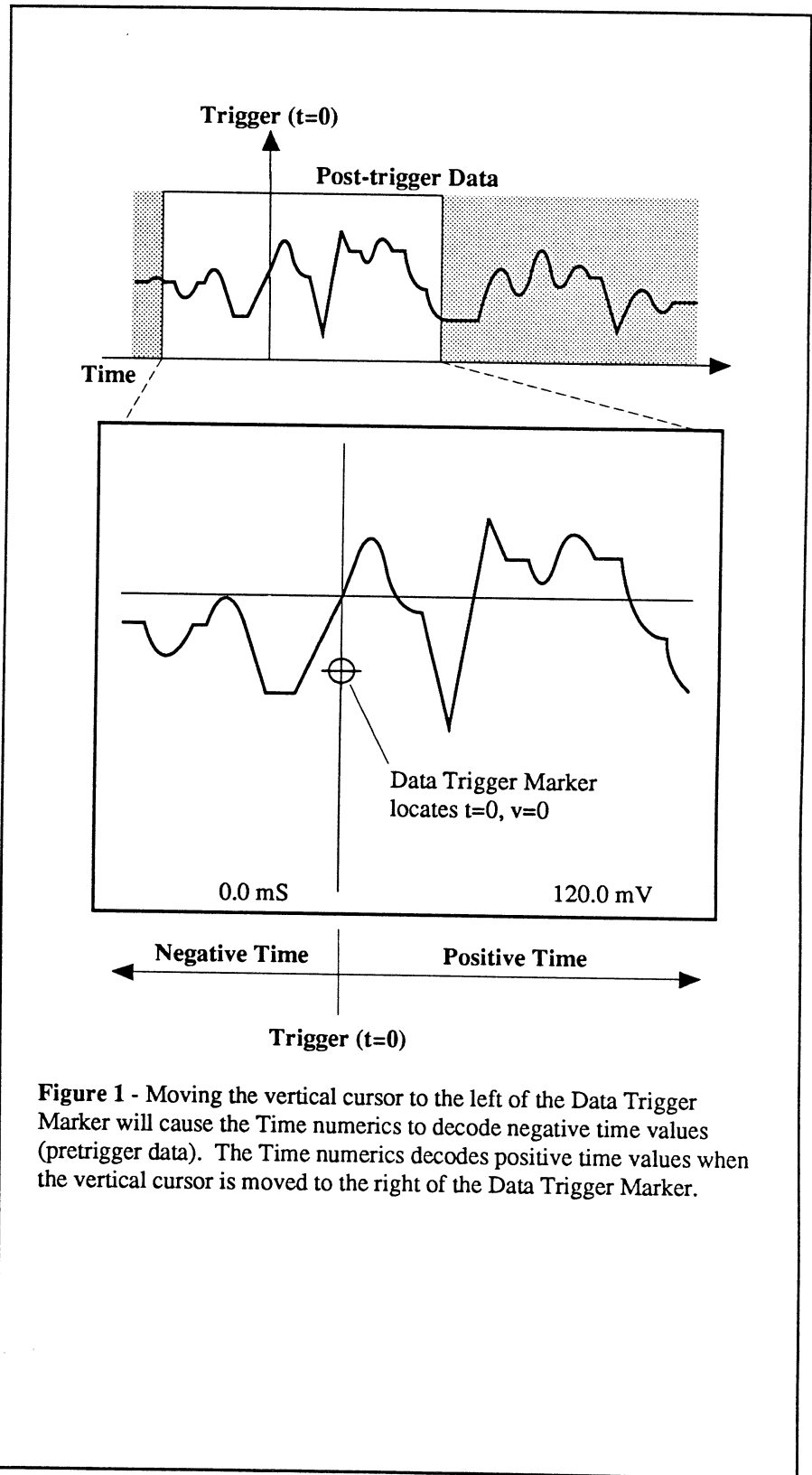

Figure 1 - Moving the vertical cursor to the left of the Data Trigger Marker will cause the Time numerics to decode negative time values (pretrigger data). The Time numerics decodes positive time values when the vertical cursor is moved to the right of the Data Trigger Marker.

Reading Time on Mid Signal Trigger Displays with $\Delta T/\Delta V$ Turned On

The $\Delta T/\Delta V$ button (Reset Numerics) allows you to select a new $t=0$ coordinate (as well as a new $v=0$ coordinate) which can be used to read comparative time measurements between any two points on the screen directly off the Time Numerics (also see *Chapter 9, $\Delta T/\Delta V$ Button*).

The time numerics will now decode time with respect to the new $\Delta T=0$ origin (identified by the $\Delta T/\Delta V$ Marker, Figure 2) rather than at the position of the Data Trigger Marker.

The Data Trigger Marker will remain in its original position on the screen to identify the original $t=0, v=0$ coordinates.

Example

Figure 2: The Mid Signal Trigger display signal was captured and then the $\Delta T=0/\Delta V=0$ coordinates were set as shown.

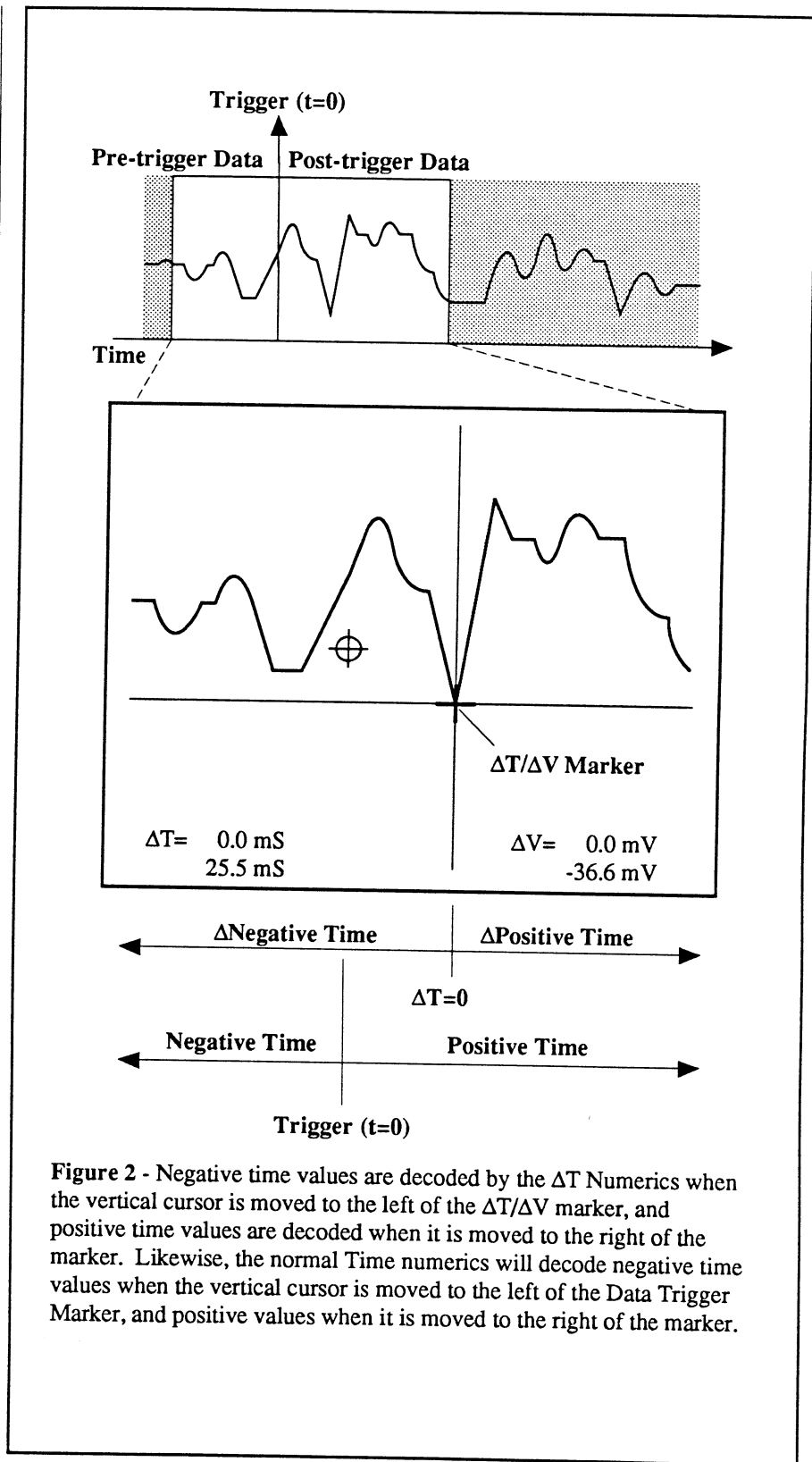
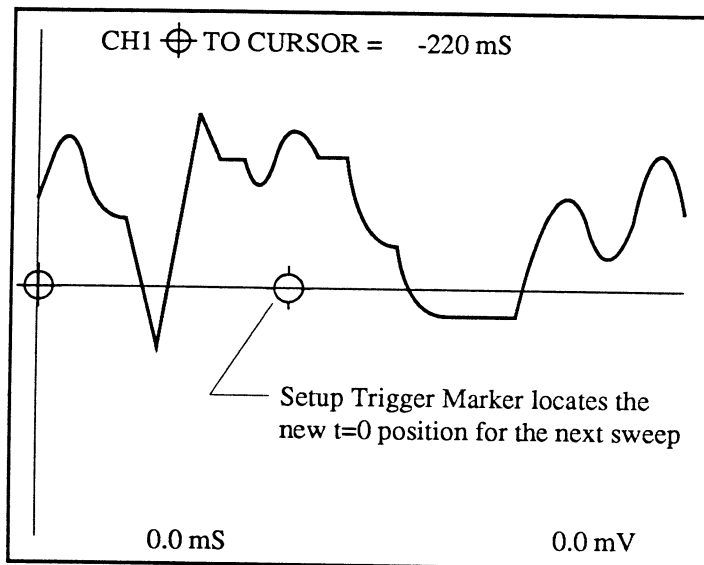

Figure 2 - Negative time values are decoded by the ΔT Numerics when the vertical cursor is moved to the left of the $\Delta T/\Delta V$ marker, and positive time values are decoded when it is moved to the right of the marker. Likewise, the normal Time numerics will decode negative time values when the vertical cursor is moved to the left of the Data Trigger Marker, and positive values when it is moved to the right of the marker.

Selecting Mid Signal Trigger Displays in the Hold Mode

Assume that you want to view what events are occurring 220 mS before a valid trigger initiates the next sweep.

1. Place the scope into the Hold Mode (Live LED off, Hold Last LED on).
2. Position the vertical cursor to extreme left edge of the screen.
3. Press the right side of the Horiz Trigger Position button until -220 mS appears at the top of the screen (Figure 3).
3. Press the Live button. The next sweep will now have 220 mS of pre-trigger data to the left of the Data Trigger Marker (Figure 4). The remainder of the screen will display post-trigger data.



Previous Trigger (t=0)

Figure 3 - The Hold Mode was selected and then vertical cursor was positioned to the extreme left edge of the screen while in the Normal Sweep mode (t=0 located at left edge of screen). The Setup Trigger Marker was moved toward the center of the screen until -220 mS was displayed towards the top of the screen.

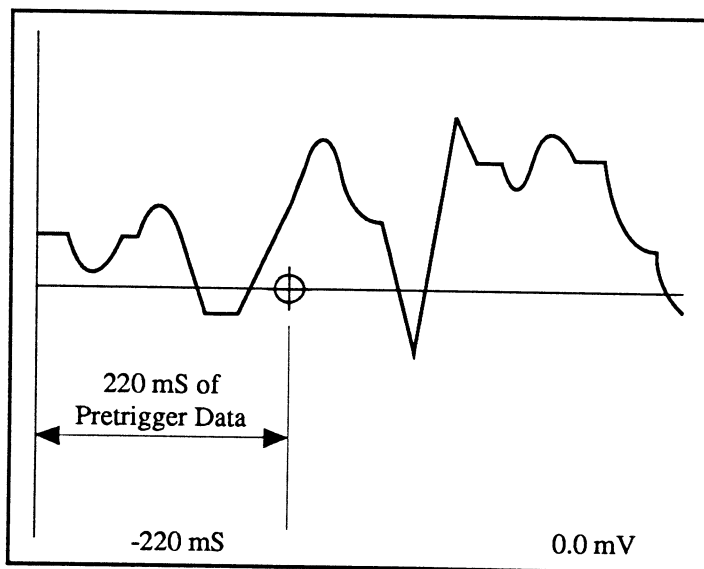

Current Trigger (t=0)

Figure 4 - Following a new sweep, the display contains 220 mS of pre-trigger data. You now can see the events leading up to the trigger, t=0.

Selecting Mid Signal Trigger Displays in the Live Mode

This procedure allows you to visually select the desired amount of pre-trigger data that will be captured for display while in the Live mode.

1. Place the scope into the Live mode (Live LED on).

Note: If capturing data while performing the next step, it will be quicker to select faster Time settings. This will reduce the sweep time which, in turn, will allow the screen to be updated with new data at a faster rate.

2. Press the right side of the Horiz Trigger Position button until the desired amount of pre-trigger data is displayed to the left of the Data Trigger Marker.

Note: Also see the "Cursor Time Lock" description in *Chapter 19*. The Cursor Time Lock function allows the instrument to maintain a constant time interval between the trigger point ($t=0$) and the position of the vertical cursor on the screen when the Time setting is changed.

Example

Figure 5: A typical Normal Sweep display with the Data Trigger Marker located at the extreme left edge of the screen ($t=0$).

Figure 6: The right side of the Horiz Trigger Position button was pressed and held in until the Data Trigger Marker and waveform moved across the screen to their current positions. Data to the left of the Data Trigger Marker now shows you which events lead up to the trigger point ($t=0$).

Figure 7: The trigger point was moved even further towards the right edge of the screen. Now over half of the screen is displaying pre-trigger data and the remainder of the screen is displaying post-trigger data.

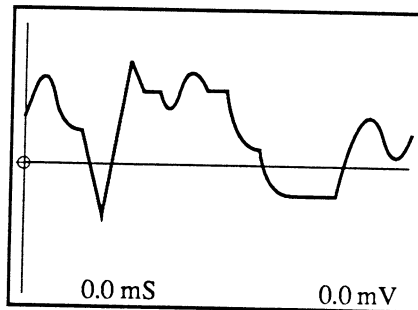

Figure 5 - Normal Sweep display with the Data Trigger Marker located at the left edge of the screen ($t=0$).

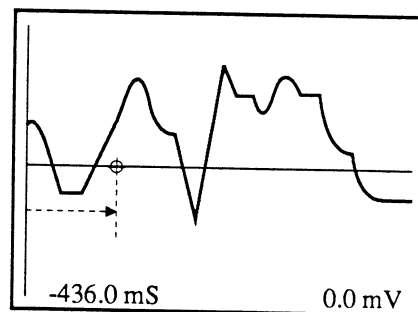

Figure 6 - The Setup Trigger Marker slides to the right while the Horiz Trigger Position button is pressed and held. Each time a new sweep is triggered, the Data Trigger Marker slides over the Setup Trigger Marker along with the selected trigger point. Note that the time numerics are prefixed with a negative sign because the vertical cursor is now decoding pre-trigger data at the left edge of the screen.

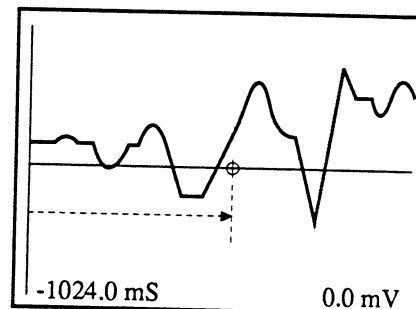

Figure 7 - The Trigger Marker continues to slide to the right, along with the trigger point on the waveform each time a new sweep is triggered.

THE DELAYED SWEEP MODE

The trigger time ($t=0$) coordinate is moved off the left edge of the screen when capturing data in the Delayed Sweep mode.

Only those events that occur after a valid trigger is received and the user-selected time delay elapses are captured for display (Figure 1).

Delayed Sweep mode data is being viewed on the screen when a \leftarrow is displayed at the left edge of the screen. The vertical position of this arrow locates the zero volts reference.

Note: The instrument defaults to the Normal Sweep Mode upon the initial application of power.

Reading Delayed Sweep Displays

All time measurements are made with respect to the trigger point which is located off screen unless the Reset Numerics function is turned on (see the next page).

Example

Figure 1 - This illustrates a typical Delayed Sweep display. Note that a \leftarrow is displayed at the left edge of the screen. This tells you that the trigger time ($t=0$) is located off the screen and you are now viewing a Delayed Sweep display.

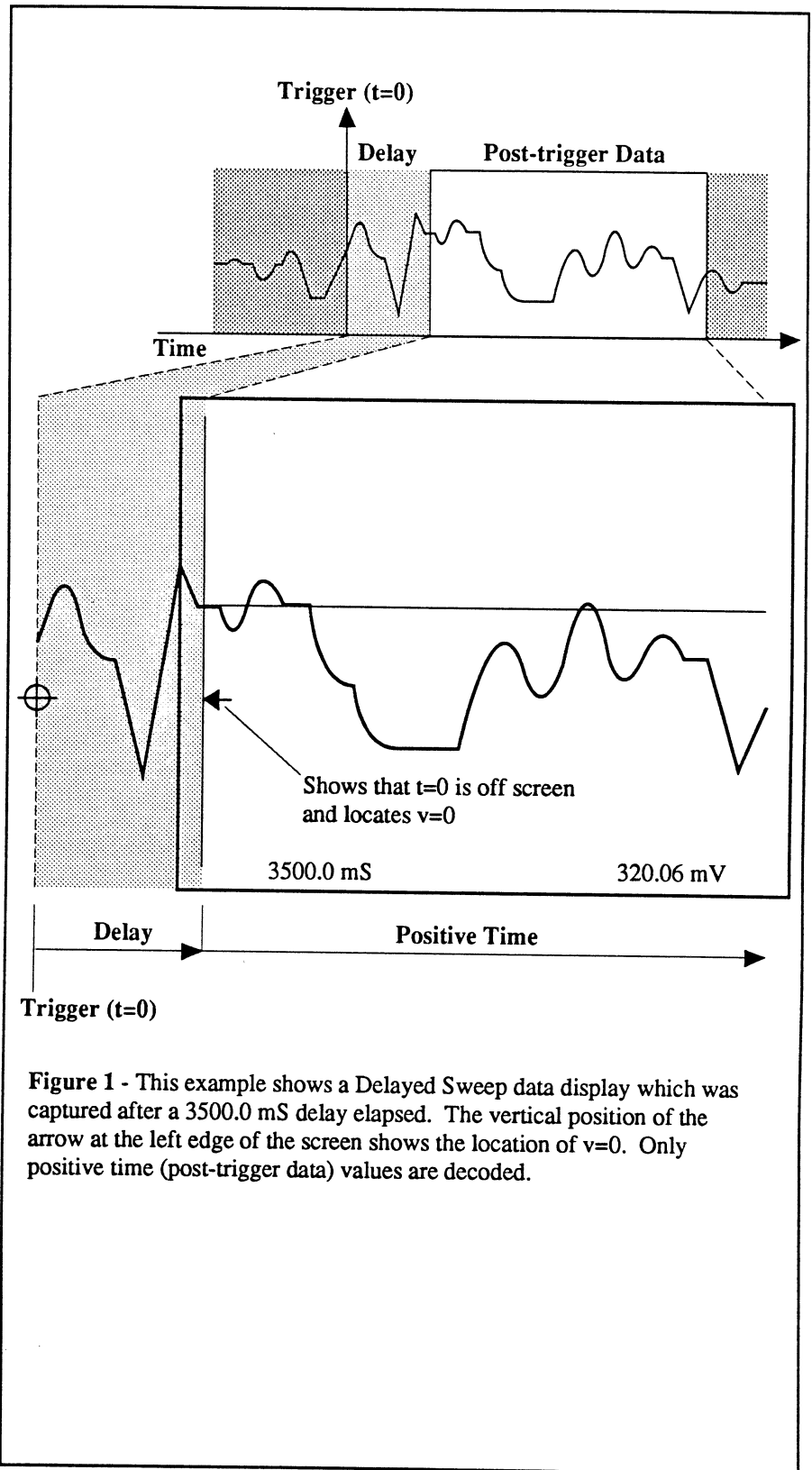

Figure 1 - This example shows a Delayed Sweep data display which was captured after a 3500.0 mS delay elapsed. The vertical position of the arrow at the left edge of the screen shows the location of $v=0$. Only positive time (post-trigger data) values are decoded.

Reading Time on Delayed Sweep Displays with $\Delta T/\Delta V$ Turned On

The $\Delta T/\Delta V$ button (Reset Numerics) allows you to select a new $t=0$ coordinate which can be used to read comparative time measurements between any two points on the screen directly from the ΔT numerics (also see Chapter 9, $\Delta T/\Delta V$ Button).

If the Reset Numerics function is turned on, the time numerics will decode time with respect to the new $t=0$ origin rather than at the position of the Data Trigger Marker.

Example

Figure 2: The signal was captured while in the Delayed Sweep mode and then the $\Delta T=0/\Delta V=0$ coordinates were set as shown.

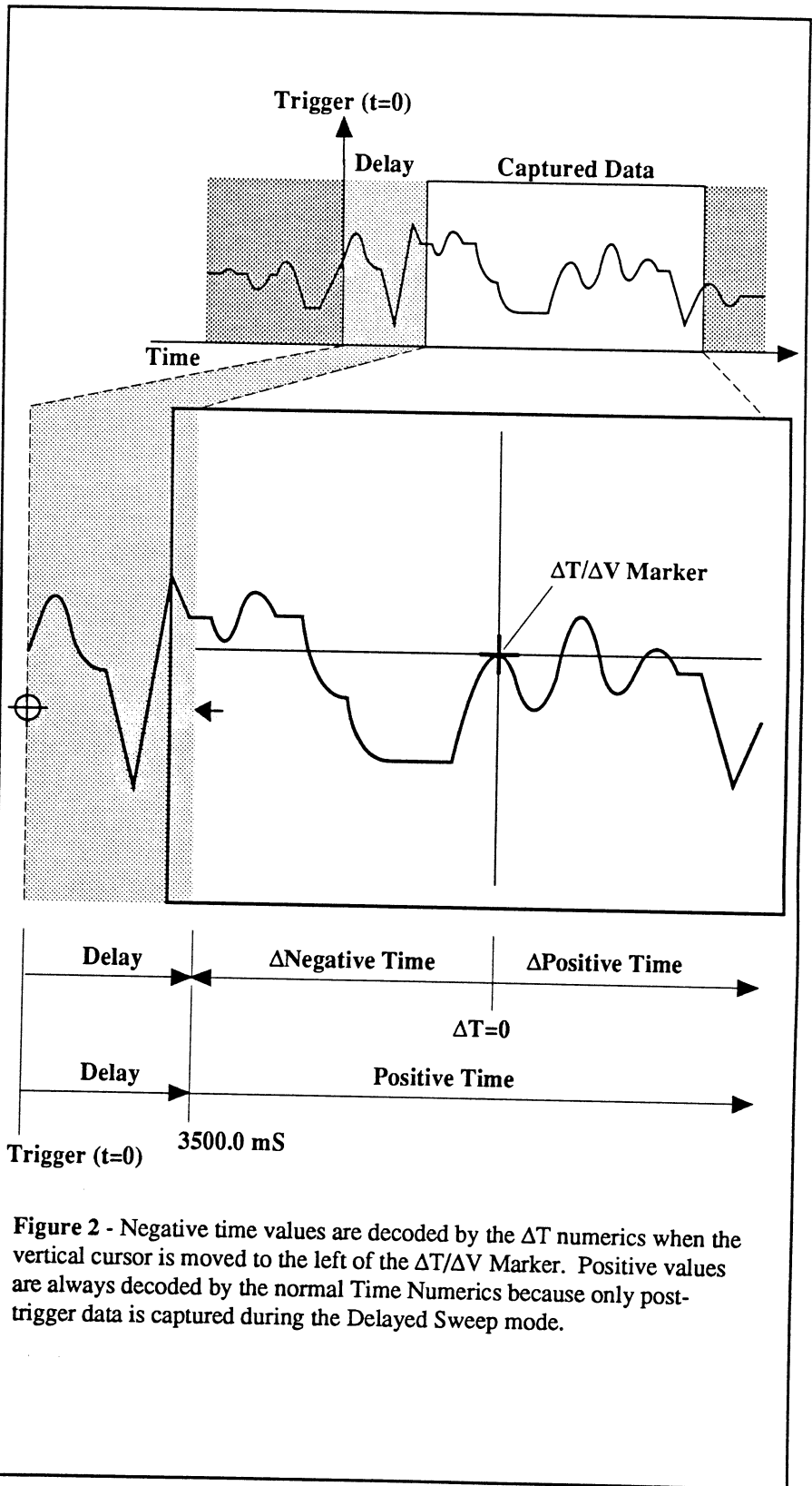

Figure 2 - Negative time values are decoded by the ΔT numerics when the vertical cursor is moved to the left of the $\Delta T/\Delta V$ Marker. Positive values are always decoded by the normal Time Numerics because only post-trigger data is captured during the Delayed Sweep mode.

Selecting Delayed Sweep Displays in the Hold Mode

Note: The maximum selectable delay time is equal to:
(Time-per-point setting x 10⁹).

Assume that you want the sweep to be initiated 500 μ S after a valid trigger is received because the first 500 μ S of data is not of any value.

1. Place the scope into the Hold Mode (Hold Last on, Live off).
2. Using the left Cursor button, move the vertical cursor to the extreme left edge of the screen.
3. Press the left side of the Horiz Trigger Position button until the desired amount of delay appears at the top of the screen (Figure 3).

Note: The delay is set by increments of the Time setting. You can select any Time setting you wish to set the delay and then return the Time setting to the desired sampling time without affecting the selected delay.

4. Press the Live button.

A \leftarrow will appear at the left edge of the screen (Figure 4) to serve as a reminder that the Delayed Sweep mode is now being used to capture data and identify the zero volts reference.

Note: Also see the Status button description on page 13-30.

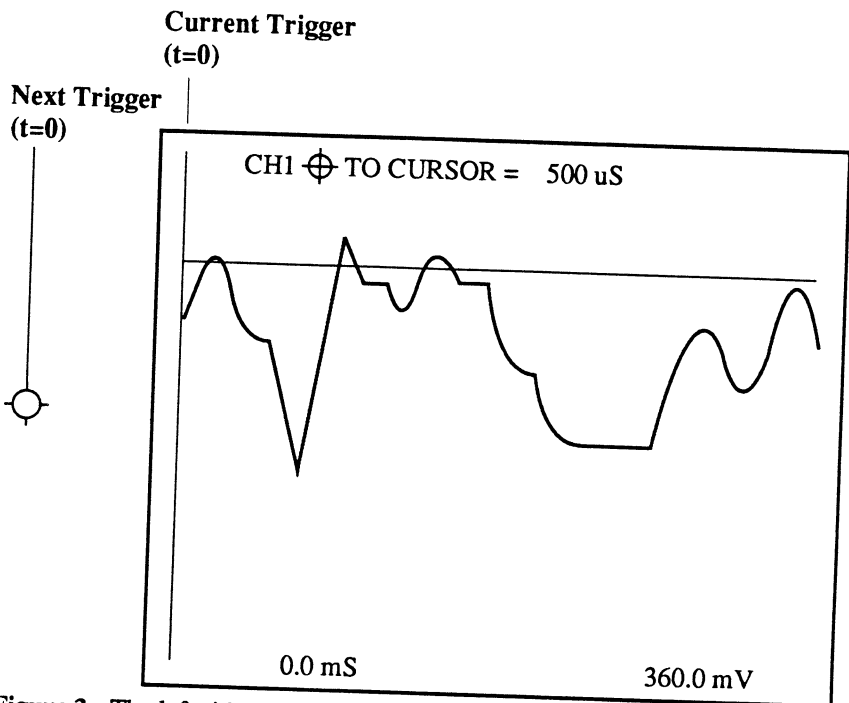

Figure 3 - The left side of the Horiz Trigger Position button was pressed and held in until 500 μ S was reached in the field at the top of the screen.

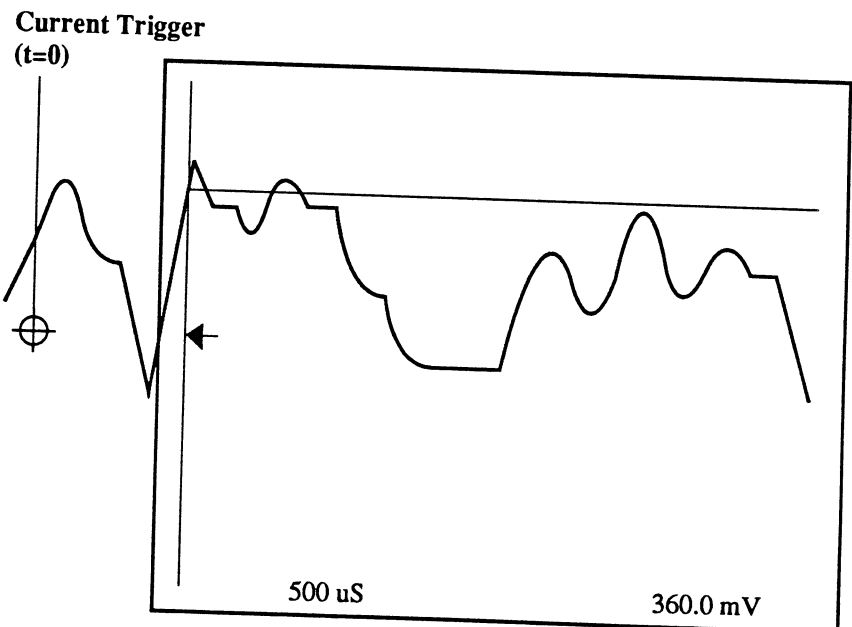

Figure 4 - After triggering a new sweep, the display now contains data that was captured 500 μ S after the trigger occurred. Note that the time numerics now reads 500.0 μ S.

Selecting Delayed Sweep Displays in the Live Mode

This procedure allows you to immediately see the effects of adjusting the time delay each time a sweep is triggered.

Note: Faster Time settings will allow you to see results sooner because sweeps will repeat at a faster rate.

1. Place the scope into the Live mode (Live LED on).
2. Press the left side of the Horiz Trigger Position button until the desired data appears on the screen.

Note: Also see the "Cursor Time Lock" description in *Chapter 18*. The Cursor Time Lock function allows the instrument to maintain a constant time interval between the trigger point ($t=0$) and the position of the vertical cursor on the screen when the Time setting is changed.

Example

Figure 5: A typical Normal Sweep mode display. The trigger point (Data Trigger Marker) is located at the left edge of the screen.

Figure 6: The left side of the Horiz Trigger Position button was pressed, thus causing the trigger point to move off the screen. Think of the screen as being stationary.

Figure 7: The trigger point was moved even further away from the left edge of the screen, thus increasing the amount of time that must elapse before data will be captured.

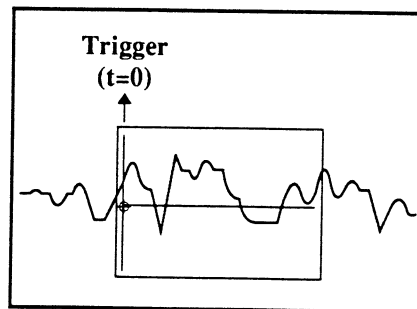

Figure 5 - Trigger time ($t=0$) is located at the left edge of the screen when capturing data in the Normal Sweep mode.

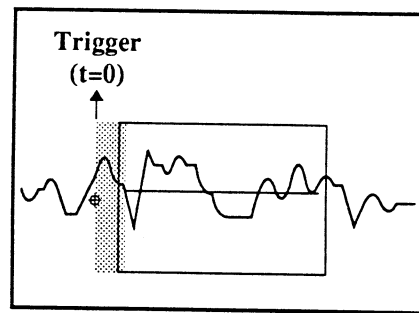

Figure 6 - Pressing the left side of the Horiz Trigger Position button causes $t=0$ to move farther away from the screen. The shaded portion represents the delay time that must elapse before the sweep will begin.

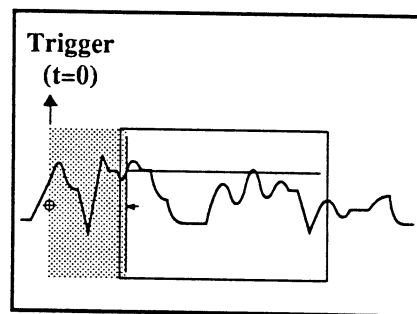

Figure 7 - The longer the time delay, the longer the instrument waits following a valid trigger to begin capturing data for display.

DERIVING TRIGGERS FROM A SINGLE SOURCE

Triggering Via the External Input BNC

Use the External Trigger Input BNC for triggering signals that may occur between the fastest digitizer time setting.

For example, a 25 nSec pulse may not trigger the 10 MHz Digitizer.

Triggering Via One of the Channel's Input BNCs

Use one of the channels to input the triggering signal if either of the following conditions apply:

- a. The triggering signal's amplitude is less than 200 mV peak-to-peak, thus it may not qualify as a valid trigger when input to the External input BNC.
- b. The triggering signal is of importance and you wish to view the trigger on the screen while viewing waveforms captured by other channels.

The channel inputting the signal can be turned on to view the signal, or it can be turned off if it is of no importance. Either way, a valid trigger received by that channel will trigger sweeps on the channels that are turned on.

MIXING TRIGGER TIMES /MODES

Selecting Independent Delays from the TRIGGER "INDEPENDENT DELAYS" menu allows you to mix trigger times and sweep modes. See *Chapter 18*, "Independent Delays" for additional information.

STATUS BUTTON

Two Status screen formats are available: Standard or Advanced Triggering.

For Standard, Front Panel Controlled Triggering

Press the Status button to display the Status screen (Figure 1) and once again to return to the waveform display. Use the Left/Right Cursor buttons to move the selection box and the Up/Down Cursor buttons to change the readouts.

Reading Triggering Parameters from the Last Sweep

This screen shows you what the triggering parameters were set for when the last sweep was triggered.

Entering New Triggering Parameters for the Next Sweep

The Status screen can be used to enter triggering parameters for the next sweep by adjusting the appropriate controls (e.g., Source button, Level/Sensitivity adjust, Time control, etc.).

Figure 1: Channel 1 parameters are highlighted in this example because it was selected as the trigger source. Note that the Level and Sensitivity values are in terms of Voltage and the Delay Time is in terms of time corresponding to the Read-Outs selections identified by the two arrows towards the bottom of the screen.

Figure 2: Level and Sensitivity are now shown in %FULL SCALE and the Delay Time is shown in SCREEN MULTIPLES selected via the Read-Outs using the Cursor buttons. Screen Multiples tells you how many screens of data were ignored from the time of the trigger until the actual sweep began. In this example 3-1/2 screens worth of data were ignored.

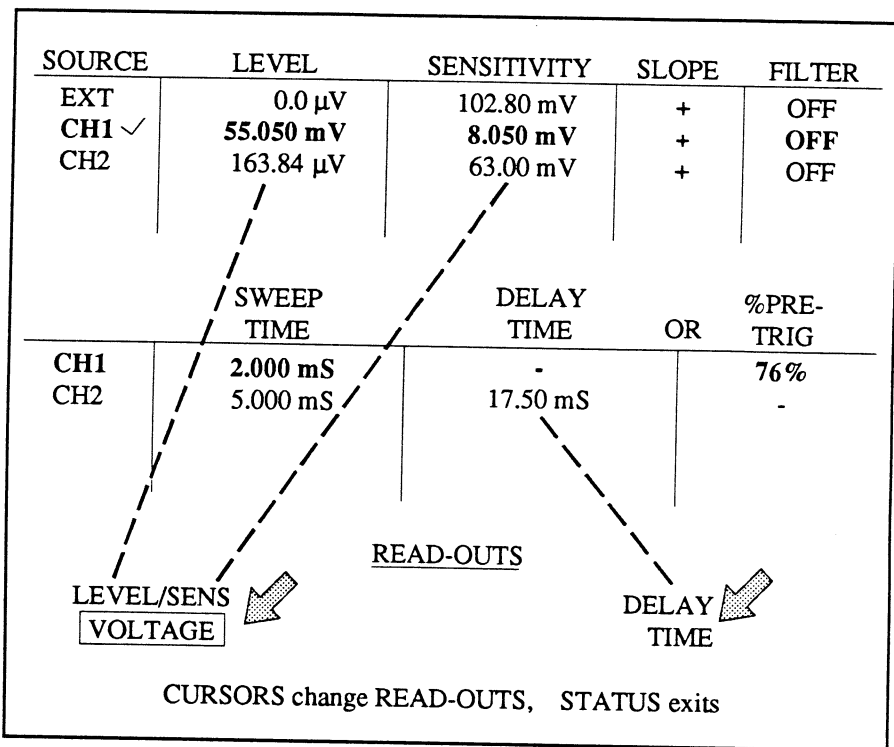

Figure 1 - Standard (not Advanced) trigger Status screen. With Level/Sens set for VOLTAGE and Delay set for TIME

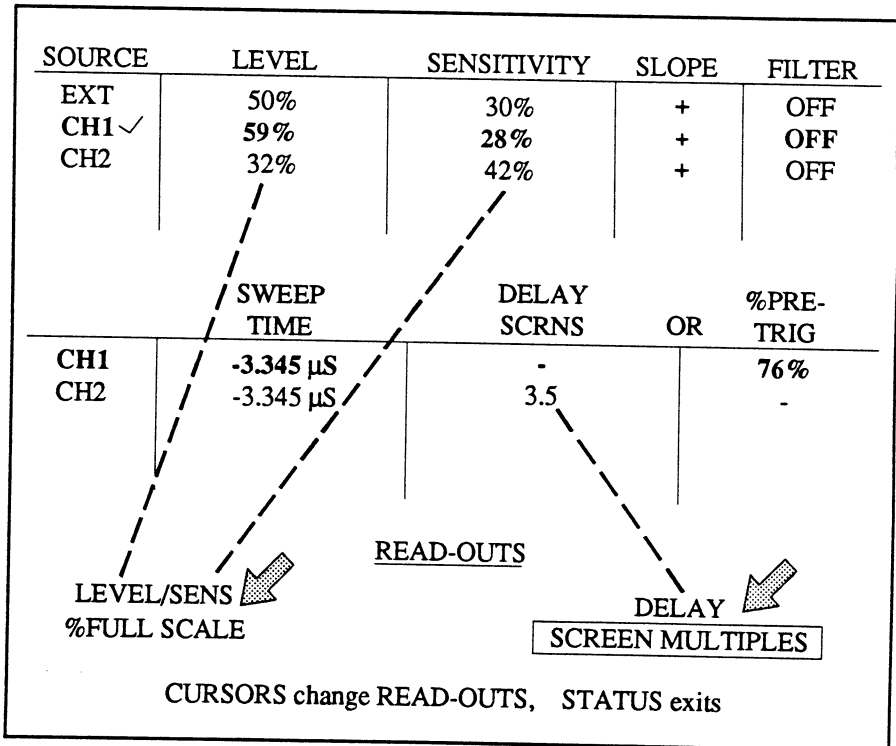

Figure 2 - Standard (not Advanced) trigger Status screen. With Level/Sens set for %FULL SCALE and Delay set for SCREEN MULTIPLES

For Glitch, Dropout, Hold Off, or n Event Triggering

The screen format in Figure 1 appears when Glitch, Dropout, Hold Off or n Event triggering is enabled on the Trigger Menu (Chapter 18). This screen operates essentially the same as on the previous page. The enabled triggering type is shown at the top of the screen. For example, Glitch triggering is shown in Figure 1. You can set different upper and lower trigger levels, but you cannot mix ARM and TRG values.

For Advanced Triggering

The format in Figure 2 appears when one of the Advanced Trigger modes is enabled on the Trigger Menu (Chapter 18).

Note: Trigger parameters can only be mixed on Pro 10, 20, 30 and 40 systems.

Because Advanced Triggering allows you to mix trigger parameters between the ARM and TRG signals, either ARM or TRG is displayed in the lower left corner of the screen (Figure 2). Use the Trigger Source button to make your selection and then the front panel controls to select the desired values.

For example, with ARM shown in the lower left corner, the upper and lower level values were adjusted to different values while the TRG signal values remain unchanged. Press the trigger Source button to adjust the TRG values.

Note: ARM or TRG is also displayed in the lower left corner of the waveform display screen when Advanced Triggering is enabled.

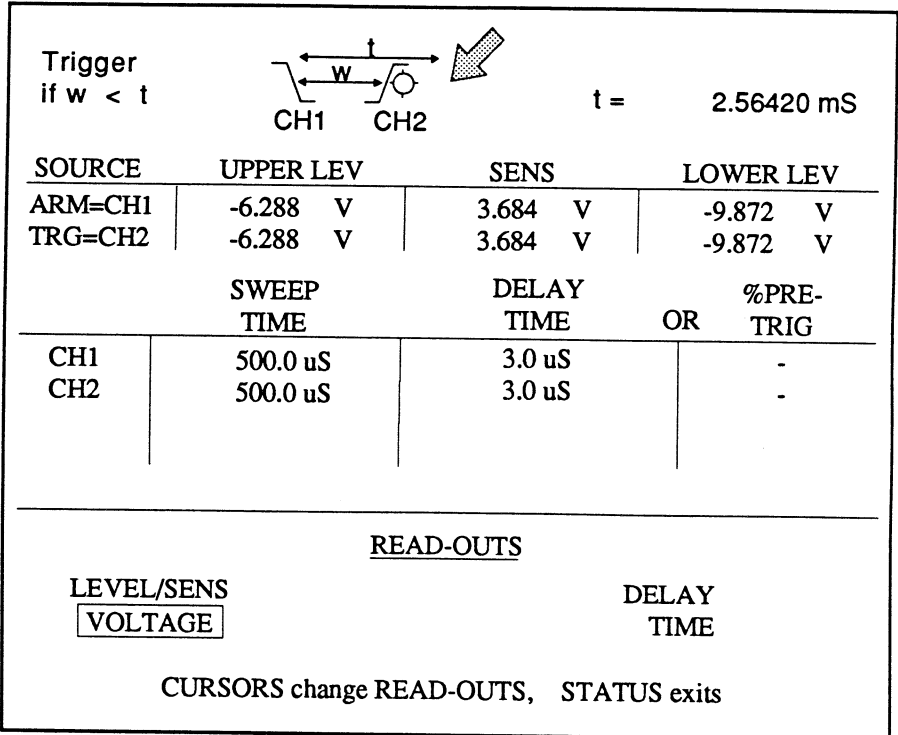

Figure 1 - Special Triggering Status screen. The enabled trigger type is shown at the top of the screen. The upper and lower trigger levels can be mixed values.

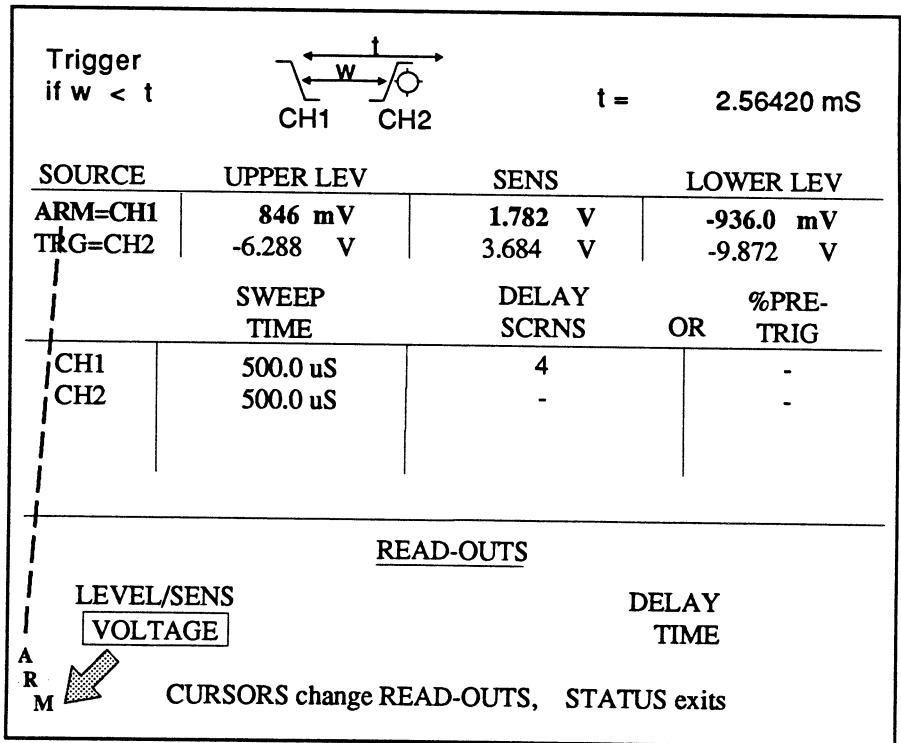

Figure 2 - Advanced Triggering Status screen. The ARM and TRG upper and lower trigger levels can now be set to different values as shown.

TRGD LED

The Trgd LED illuminates throughout every sweep, enabling you to quickly determine whether a valid trigger has been received.

This is useful during very long sweeps because the trace can move across the screen so slowly that it is not visually detectable.

Note: To confirm that the signal is actually being captured during very long sweeps:

- a. Turn Autocenter on.
- b. Position the crosshair toward the left edge of the screen.
- c. Apply Horizontal Expansion.

With the proper amount of expansion, each data point should appear on the screen as it is captured. It may be necessary to reposition the expanded waveform using the Left/Right Cursor buttons to locate the last data point captured up to that point in time.

ARM LED

The Arm LED illuminates according to the selected "trigger mode."

Normal Trigger

The Arm LED illuminates as soon as the LIVE or HOLD NEXT button is pressed. It remains illuminated until after a valid trigger occurs and the sweep is completed.

Note: If you are using the Mid Signal Trigger mode, a pretrigger buffer memory must be filled before a valid trigger is recognized. The Arm LED remains off until the buffer is full. This will be more noticeable during very long, Mid Signal Trigger sweeps.

Advanced Trigger

The advanced triggering modes are selected by the Trigger Menu (*chapter 18*). These are Glitch, Dropout, Hold Off, n Event and Adv Triggering.

The Arm LED illuminates after a qualifying event is received to activate the timer/counter. It remains on until a sweep is triggered and that sweep is completed.

Note: If the timer is reset because a valid trigger did not qualify within the allowed time, the Arm LED turns off and then on again when the scope is rearmed.

COMPENSATION POINT

A square wave is displayed when the optional x10 or x100 test probes are touched to the compensation point while in Live LED is on.

Important: The Time Per Point should be set to 100 nS.

The square wave is used to compensate the test probes for optimum response times. Use display expansion to fine tune the adjustments.

Example

Figures 1 and 2 illustrate two examples of an uncompensated test probe with display expansion applied. Figure 3 illustrates the optimum result of a properly compensated probe.

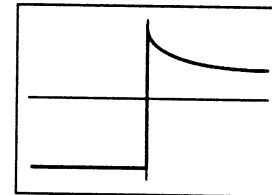

Figure 1 - Uncompensated Probe

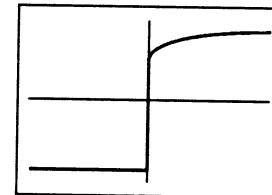

Figure 2 - Uncompensated Probe

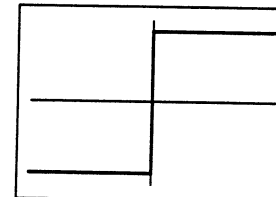

Figure 3 - Compensated Probe

Chapter 14

THE RESIDENT

MENUS

GENERAL —————	Chapter 14	DISPLAY —————	Chapter 19
Accessing the Menus	14-2	Cursor/Grid Options	19-2
Making Menu Selections	14-3	Dot-Join	19-3
PROGRAMS —————	Chapter 15	User Units	19-4
FFT Snapshot	15-2	Channel Title	19-6
Recall Program	15-5	Print Screen	19-7
Clear All Programs	15-6	Max/Min	19-8
LEARN —————	Chapter 16	DISK —————	Chapter 20
Start Learning	16-2	Store Setup	20-2
Stop Learning	16-4	Recall Setup	20-3
Execute Batch	16-4	Initialize MSO	20-4
• Aborting a Batch	16-4	Copy File	20-5
Store Batch	16-5	Delete File	20-6
Recall Batch	16-5	Format Disk	20-7
Print Batch	16-7	Directory	20-8
ACQUISITION ———	Chapter 17	Plot From Disk	20-9
Sweep Length	17-2	SYSTEM —————	Chapter 21
Input Filters	17-4	Setup To Ram	21-2
Autocycle to Disk	17-5	Setup From Ram	21-2
Summation Average	17-9	I/O Parameters	21-3
Dual Sample Rates	17-10	Printer Output	21-4
TRIGGER —————	Chapter 18	Set Date/Time	21-5
Cursor Time Lock	18-2	Beeper	21-6
Independent Delays	18-4	High Res Auto Set-up	21-7
'OR' Triggering	18-5	About	21-8
Level/Sens Lock	18-6	TESTS —————	Chapter 22
Master/Slave	18-7	Front Panel Test	22-2

This chapter contains general information about accessing the resident menus and making selections from those menus. Chapters 15 through 22 describe each of the eight menus and their respective functions.

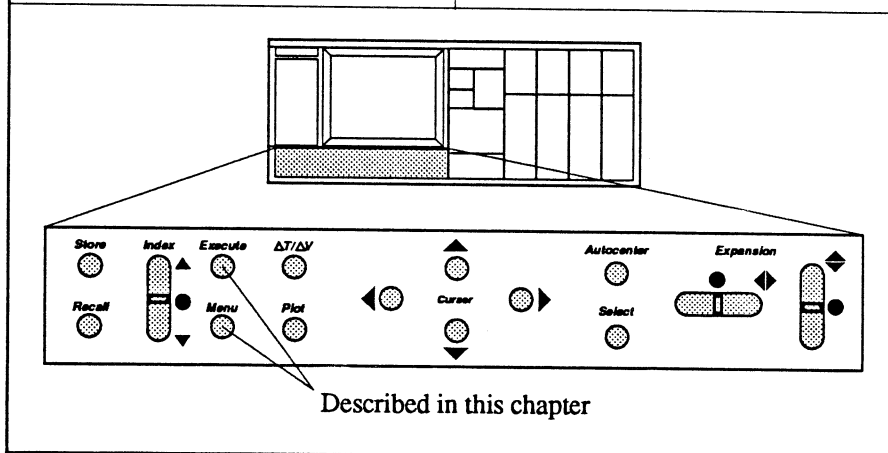

ACCESSING THE MENUS

Press the Menu button to access the resident menus. The default menu display in Figure 1 will appear when the Menu button is pressed following the initial application of power to the instrument.

Note: If the Menu button is pressed during an active sweep, the instrument will automatically enter the Hold Mode and the sweep currently in progress will be aborted. Data captured during the previous sweep will remain intact.

Exiting the Menu Mode

The Menu mode can be exited at any time by pressing the MENU button again. This will return the waveform display.

Defaults

The instrument defaults back to the last Menu or Function selection each time the Menu Mode is reactivated.

For example, if the Sweep Length function was the last function to be executed, the instrument will automatically return to Sweep Length when the next time that the Menu button is pressed to reenter the Menu mode.

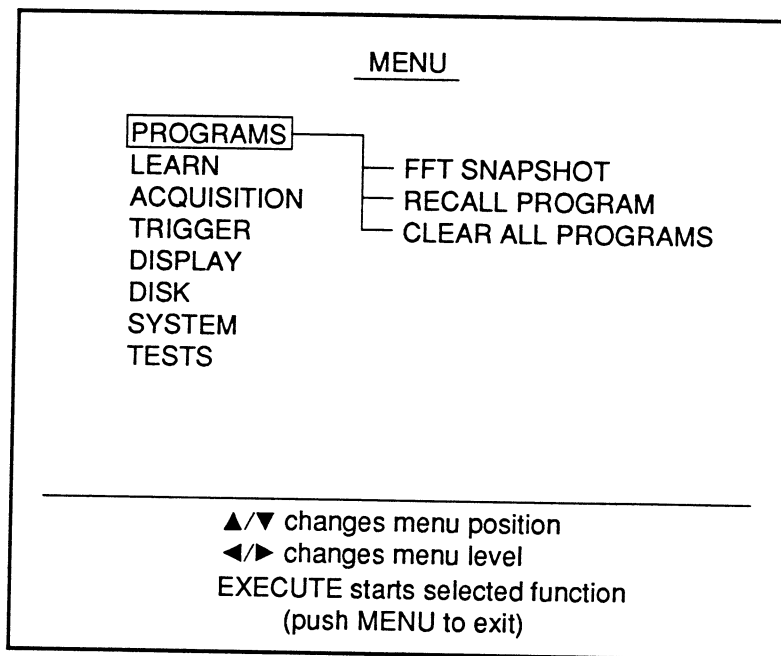

Figure 1 - The default PROGRAMS menu display when the Menu button is pressed following the initial application of power.

MAKING MENU SELECTIONS

When making selections on the Menu screen, you can either press the Up or Down Cursor buttons or you can rotate the TIME control knob to move the cursor vertically. Press the Left or Right Cursor buttons to move the cursor horizontally.

Note: Rotating the TIME control knob while the cursor is in the right hand column of functions allows you to change menus without moving the cursor to the left hand column.

The following example illustrates how to select the INPUT FILTERS function accessed via the ACQUISITION menu.

Example

Figure 1: The Down cursor button was pressed until the cursor selected ACQUISITION.

Figure 2: The Right Cursor button was pressed to move the cursor to the Functions list and then the Down Cursor button was pressed until the cursor moved over INPUT FILTERS.

The INPUT FILTERS function can now be executed by pressing the Execute button.

Note: When the cursor reaches the last function in the list, you can quickly return to the beginning of the list by pressing the Down Cursor button. This also applies to the Up Cursor button when moving the cursor upwards in the list of functions.

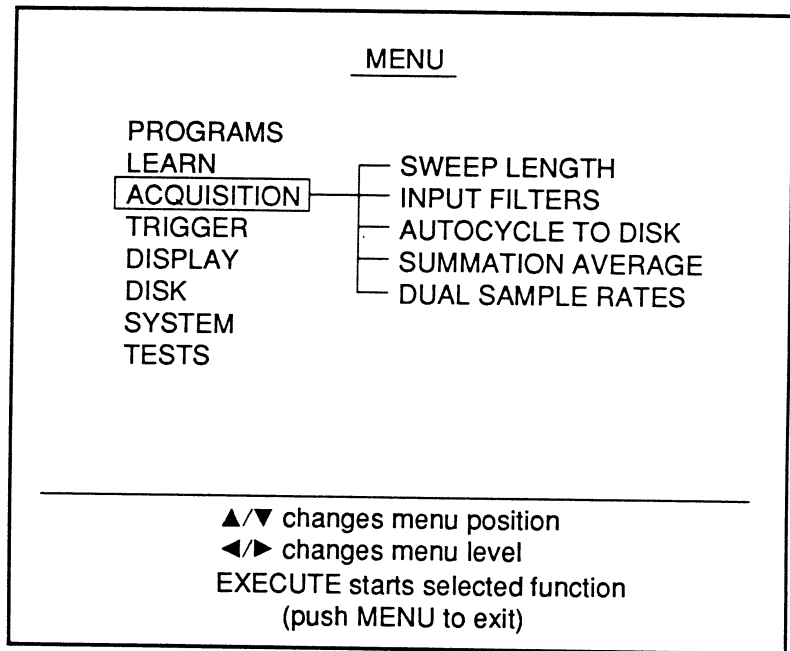

Figure 1 - The Down Cursor button was pressed until ACQUISITION was selected.

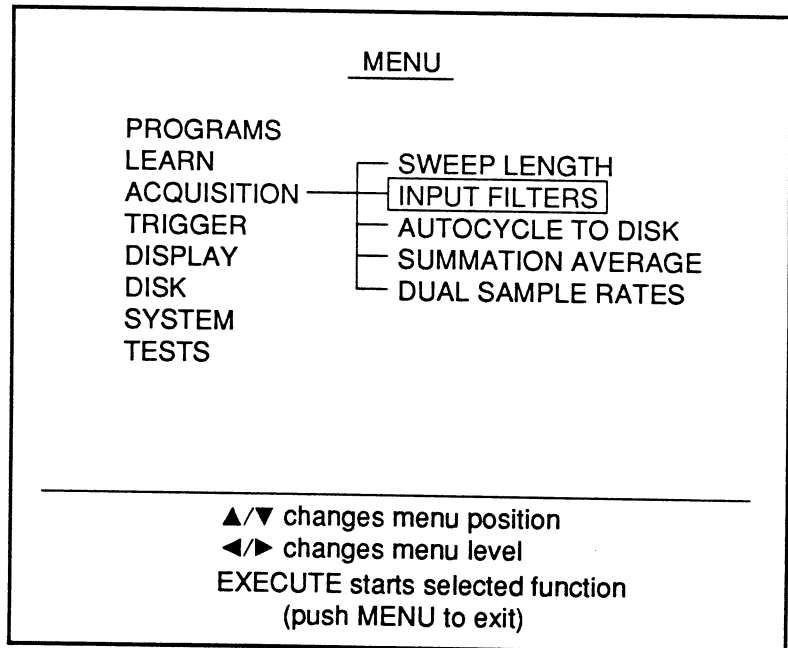

Figure 2 - The Right Cursor button was pressed and then the Down Cursor button was pressed to select INPUT FILTERS.

Chapter 15

THE PROGRAMS

MENU

FFT Snapshot	15-2
Recall Program	15-5
Clear All Programs	15-6

The **Programs** menu allows you to turn time domain waveforms into frequency domain waveforms with the FFT Snapshot function. It also allows you to download programs available from the optional Waveform Processing Package disk. These programs are used to manipulate waveform data stored in memory.

When the downloaded programs are no longer required, use the Clear All Programs function to clear all of the programs from memory.

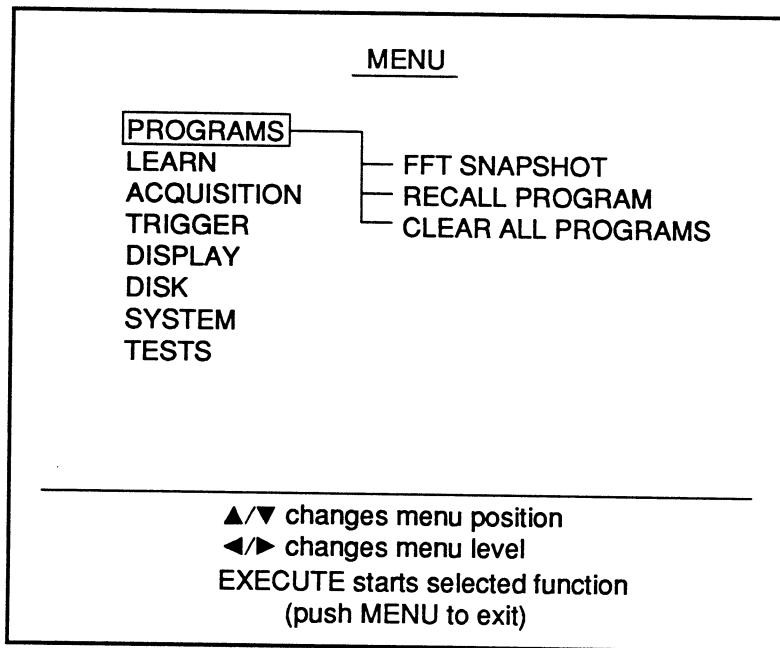

Figure 1 - The PROGRAMS menu display

FFT SNAPSHOT

FFT Snapshot allows you to convert captured time domain waveforms into frequency domain waveforms. This also includes time domain waveforms stored in the Sweep Review memory. The instrument must be in the Hold Last mode to use FFT Snapshot.

1. Execute FFT SNAPSHOT. A screen appears (Figure 2).
2. Using the Cursor buttons, enter YES, the desired Zoom Factor (1 to 999), select the Source Channel storing the waveform, and then the Destination Save Ref location where the result will be stored.
3. Press EXECUTE. A warning screen appears. Press EXECUTE to continue or MENU to exit.

CAUTION: Pressing EXECUTE to continue will null all data stored in memory.

4. Capture the waveform and then enter into the Hold Last mode.
5. Press EXECUTE. Both the time domain and its FFT will be displayed on the screen.
6. Press EXECUTE to perform additional FFT Snapshots.

Important: If you press the Menu button or use the Execute button to initiate another function (e.g., initiate a plot or a downloadable function) you must reselect FFT SNAPSHOT and then press EXECUTE twice to redefine the EXECUTE button for FFT Snapshots.

Disabling FFT Snapshot

Press MENU, select FFT Snapshot, press EXECUTE, enter NO (Figure 2) and then press EXECUTE. See the **Caution** note above.

Continued on the next page.

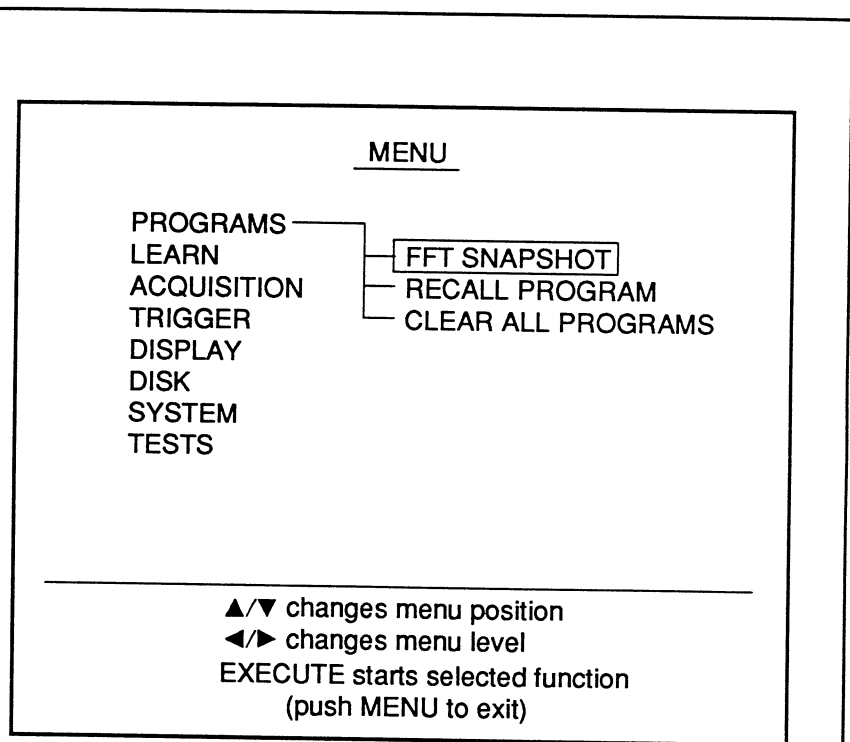

Figure 1 - FFT Snapshot Program

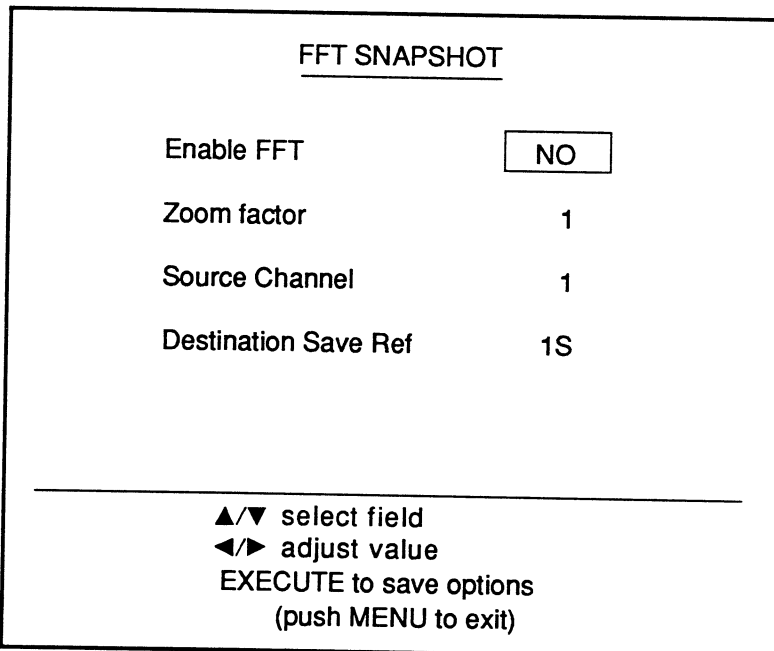

Figure 2 - FFT Snapshot parameter screen

Technical Services Statistics

Date _____ Time _____

S/N _____

User _____

Phone # _____

SYMPTOM

- _____ A Hardware Failure
- _____ B Hardware Operation
- _____ C Software Operation
- _____ D Software Bugs
- _____ E Software Loading
- _____ F Applications
- _____ G Part Numbers
- _____ H Quotation Information
- _____ I Repeat Call/Message to Rep

CUSTOMER TYPE

- _____ A Service Contract
- _____ B Warranty
- _____ C Demand
- _____ D Field Engineer
- _____ E Sales Eng/Rep/Subsid.
- _____ F Information/Future Customer

Initials _____ Passed to _____

_____ Need to Correct Data Base Info

Company _____

Address _____

SYSTEM TYPE

- _____ A Magna
- _____ B G-Series
- _____ C 60/170/800
- _____ D Impact
- _____ E Raman
- _____ F ECO
- _____ G OMNIC Upgrades
- _____ H SCOPES
- _____ I 205/8200
- _____ J Other _____

ACCESSORIES

- _____ A Microscopes
- _____ B GC-IR/TGA
- _____ C Libraries
- _____ D Macros
- _____ E Gas Cells
- _____ F Spectra Tech Accys
- _____ G Others _____

NOTES _____

_____ A Phone Fix _____ B Opened call _____ C Left Message _____ D Phone Mail _____ Rep#

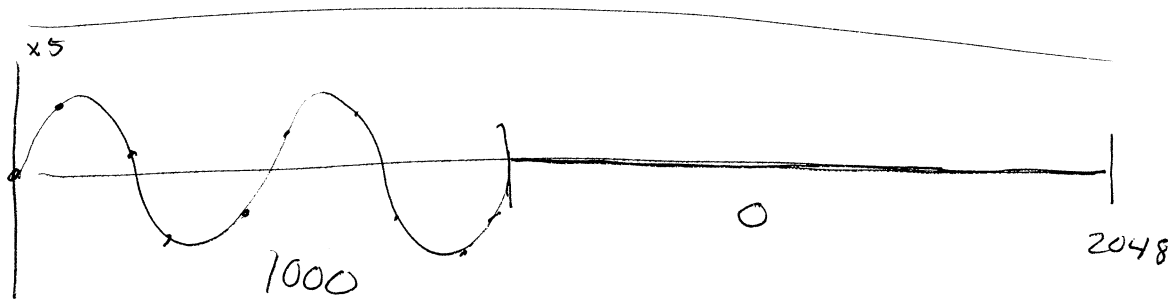

$$N = 2048$$

results

$$\underline{1024 \text{ points} + DC} = 1025$$

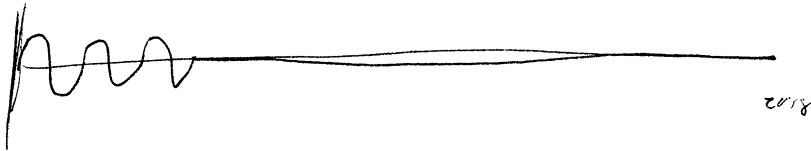

Description

When the FFT Snapshot function is enabled, the Sweep Length automatically defaults to 1000 points and cannot be changed until FFT Snapshot is disabled again.

CAUTION: Enabling or disabling the FFT Snapshot function nulls all waveform data stored in memory.

Enabling the FFT Snapshot function reduces the number of waveforms that can be stored in the Sweep Review memory. To regain full use of the memory, disable the FFT Snapshot function when not in use.

The FFT Snapshot takes a 1000 point time domain waveform and adds nulls to pad it to 2048 points. The resulting FFT is 1025 points long, but only the first 1000 points are displayed on the screen.

The Zoom Factor

The zoom factor is used to horizontally expand the low frequency portion of the FFT. It can be set from 1 to 999 and has no effect on the time domain waveform. This produces a more pleasing, simultaneous display of time and frequency domain waveforms. See Figures 1 and 2 on this page.

The zoom factor determines which data points are used to obtain the FFT. A zoom factor of five, for example, selects only every fifth data point. The maximum frequency of the FFT in this example will be one-fifth of the maximum frequency with no zoom factor. This is further illustrated on the next page.

Note: The zoom factor should only be used when all of the FFT results are compressed towards the left edge of the screen.

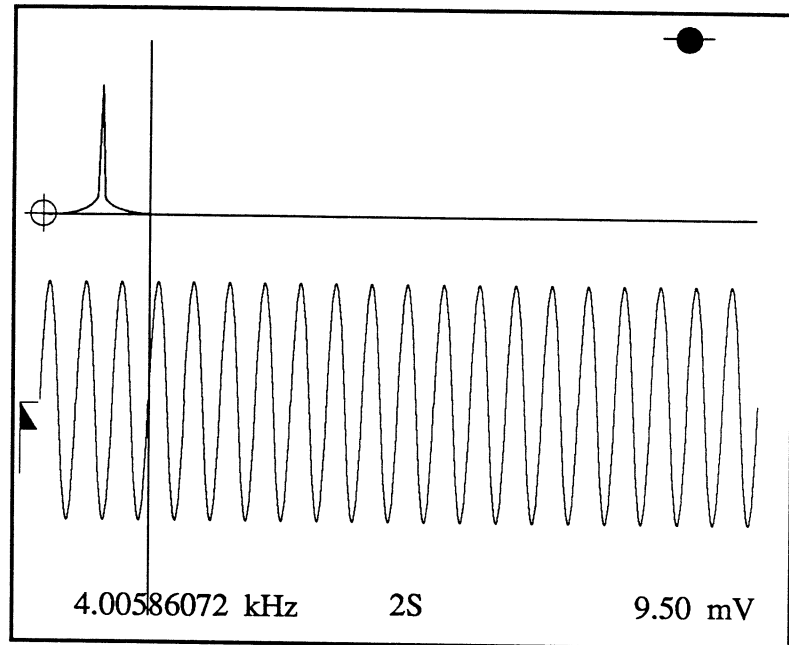

Figure 1 - FFT Snapshot display with the Zoom Factor set to 1.

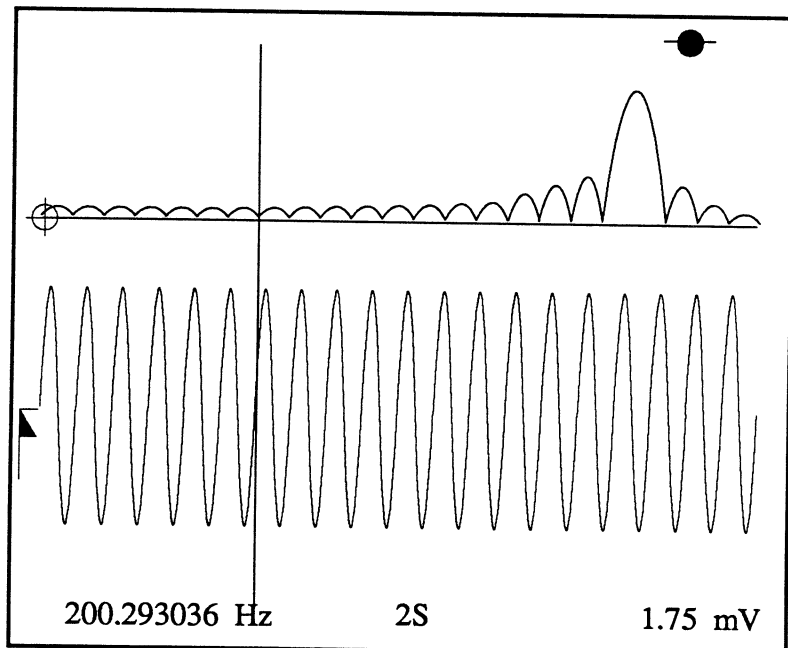

Figure 2 - The Zoom Factor was set to 10 and then the FFT Snapshot function was executed again on the same signal as in Figure 1.

The Zoom Factor and Aliasing

If the zoom factor is used incorrectly, it may cause aliasing and give invalid results.

Example 1 - Proper use of the zoom factor

Figure 1 shows the result of performing a FFT with no zoom factor on 5 cycles of a 1 MHz sine wave. The results of the FFT are all located at the far left edge of the screen.

Figure 2 shows the same signal after performing a FFT with a zoom factor of 10.

Note that the frequency of the fundamental is 977 kHz in figures 1 and 2. Also note that the frequency at the far right edge of the FFT in Figure 2 is one-tenth of that in Figure 1. This is because only every tenth data point is being used in Figure 2 due to the zoom factor of ten.

Example 2 - Improper use of the zoom factor

Figure 3 shows the result of performing a FFT with no zoom factor on 50 cycles of a 10 MHz sine wave. Note that the results are not compressed towards the left edge of the screen.

Figure 4 shows the aliased result after performing a FFT with an excessively large zoom factor of 15.

Note: The frequency of the fundamental in Figure 4 is an erroneous 3.4 MHz rather than the correct 9.96 MHz as shown in Figure 3. This erroneous data resulted from aliasing.

Proper use of the Zoom Factor

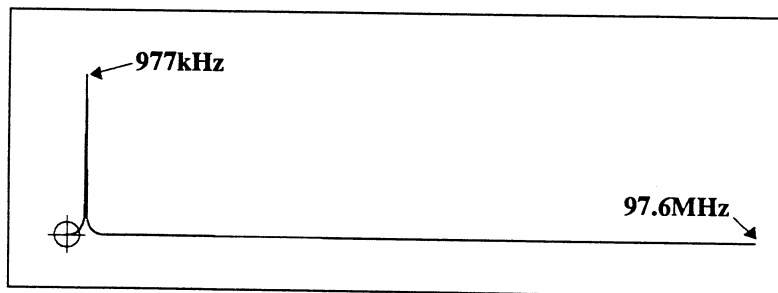

Figure 1 - FFT without a zoom factor; data is compressed at the left edge.

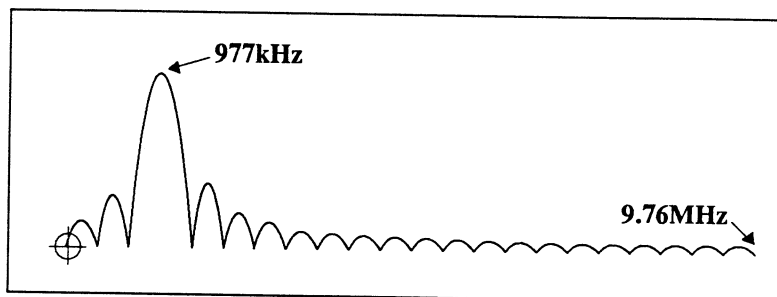

Figure 2 - Valid data is still produced after applying a zoom factor of 10.

Improper use of the Zoom Factor

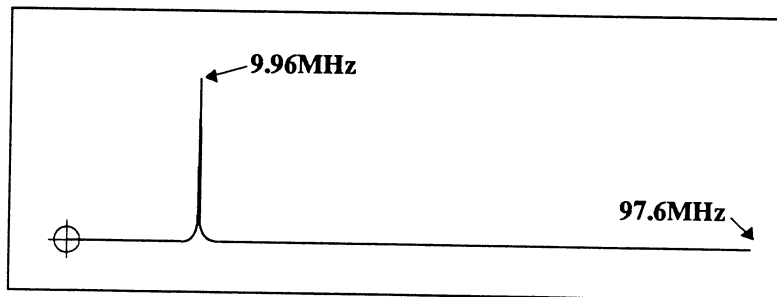

Figure 3 - FFT without a zoom factor; data away from the left edge.

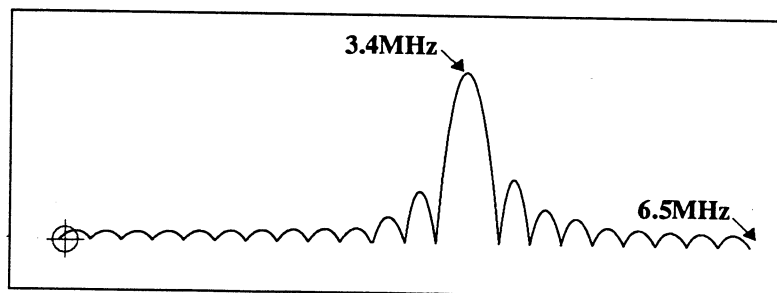

Figure 4 - Aliasing produced erroneous data after using a zoom factor of 15.

RECALL PROGRAM

Recall Program is used to recall a downloadable program furnished on the Waveform Processing Package, 3.5 inch floppy disk available from Nicolet and store the program in the instrument's memory.

The downloaded program can then be used to mathematically manipulate the captured data for specific investigations.

Note: The Waveform Processing Package can also be copied onto the optional Pro Disk's hard disk drive available from Nicolet for permanent storage.

The "disk bytes free" field (Figure 2) shows you how much memory is still available on the disk.

1. Move the cursor to **RECALL PROGRAM**.
2. Press **EXECUTE**. The Recall Program Selection Screen will appear (Figure 2).

Note: The Select button is used to change the function of the Cursor buttons between "CURSORS change file pointer" and "CURSORS change drive/path."

3. Press the Select button and then use the Cursor buttons to select the desired drive/path.
4. Use the Cursor buttons to select the desired file.
5. Press the Execute button to recall the selected program.

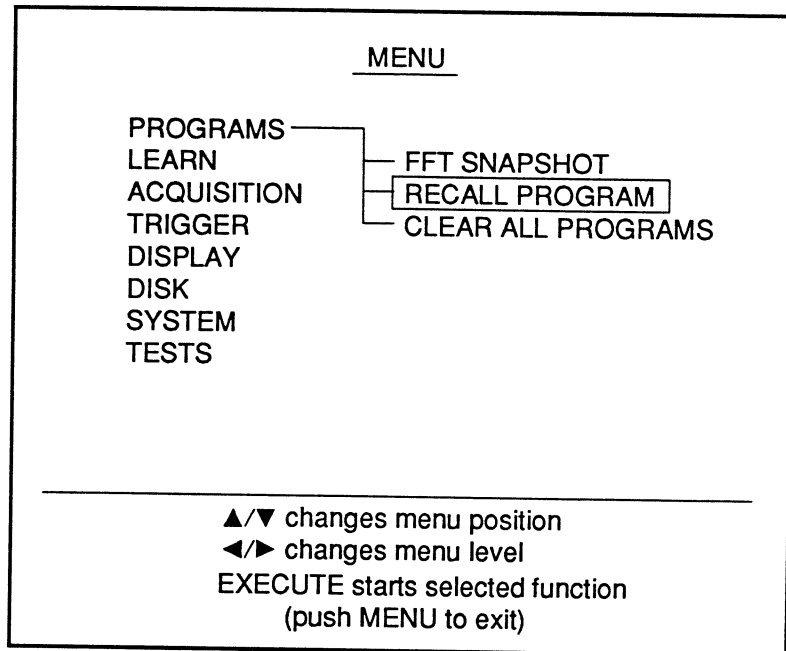

Figure 1 - Recall Program

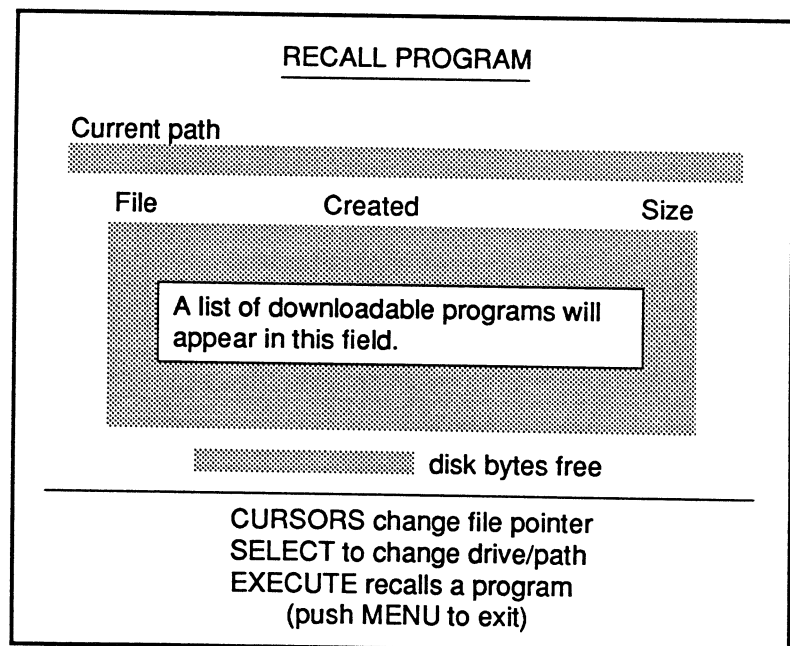

Figure 2 - Recall Program Selection Screen

CLEAR ALL PROGRAMS

Clear All Programs is used to clear all of the downloaded programs from the instrument's memory when they are no longer needed to manipulate the captured data.

1. Move the cursor to CLEAR ALL PROGRAMS.
2. Press EXECUTE.

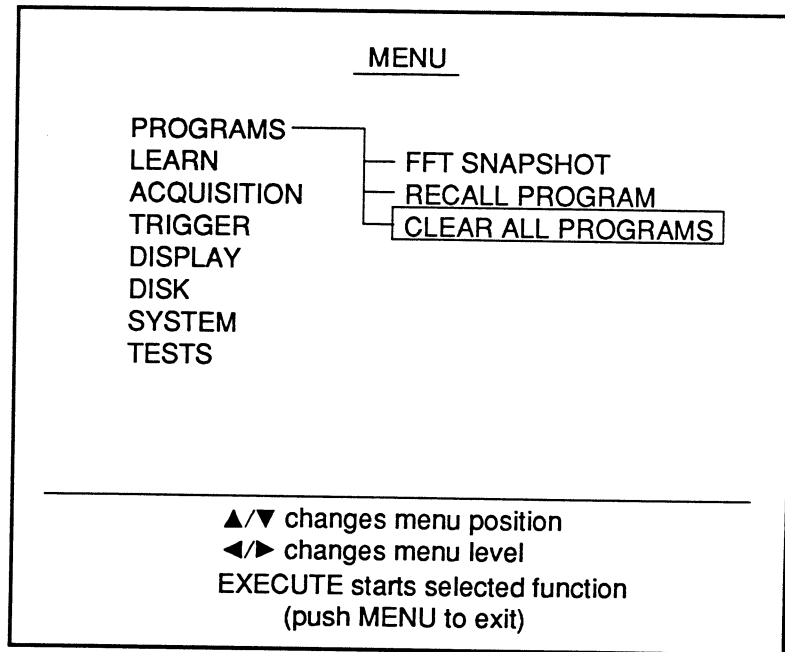

Figure 1 - Clear All Programs

Chapter 16

THE LEARN

MENU

Start Learning _____	16-2
• Helpful Hints	16-2
Stop Learning _____	16-4
Execute Batch _____	16-4
• Aborting a Batch	16-4
Store Batch _____	16-5
Recall Batch _____	16-5
• Batches and the PC	16-6
• Batch File Requirements	16-6
Print Batch _____	16-7

Learn allows you to create a batch of functions/programs/front panel settings which can be used to automatically perform specific tasks in the same sequence as they were added to the batch.

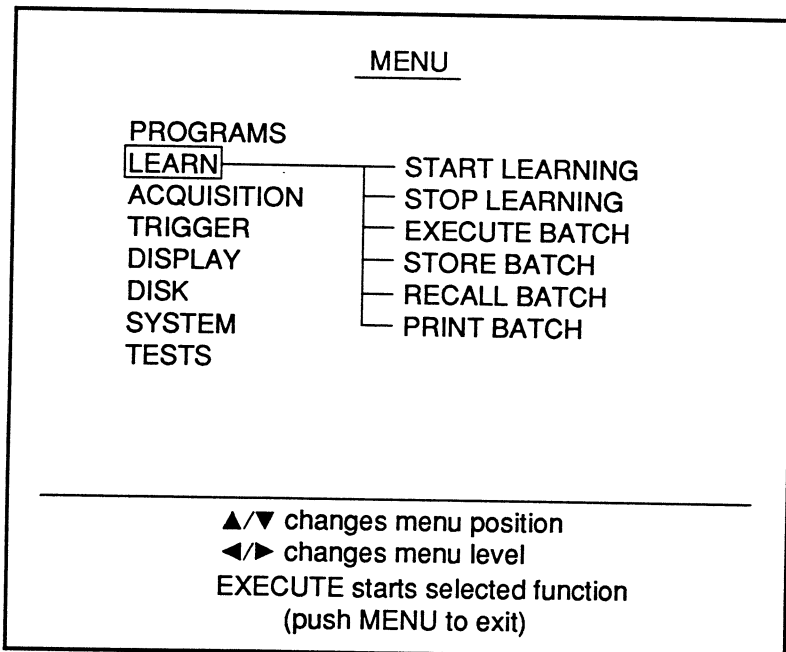

Figure 1 - The LEARN menu display

START LEARNING

Start Learning allows you to build a batch of functions/programs which, when **Execute Batch** is executed, will automatically sequence in the same order that they were selected. The word **LEARN** appears at the top left of the waveform display while in the Start Learning mode.

Note: Learnable functions/programs are displayed brighter on the screen; nonlearnable functions/programs are dimmed. You can execute nonlearnable functions/programs, but they will not be included in the batch. Also, the word **LEARNABLE** appears at the lower left corner of each menu screen while in the **START LEARNING** mode.

Helpful Hints for the Learn Mode

- a. For front panel controls, only the end result of your action is stored. For example, if the **Volts** button is pressed four times to set it to 300 mV, the stored command is **RANGE 0.3**, not the four button presses.
- b. For the greatest versatility, entering Learn mode does not save the front panel settings. If you desire a particular front panel setup each time the batch is executed, the first action in your batch may be the **SYSTEM** menu item **RECALL SETUP FROM RAM**. The front panel **Auto Setup** button may also be used to establish input settings.
- c. In general, it is recommended you not recall a program from disk while in the Learn mode. The program will be recalled as expected, but it will also be recalled again each time the batch is executed, wasting time.
- d. The **Hold Next** button will cause the instrument to wait for the next trigger. If the trigger controls are not set correctly, or a trigger is not received, the instrument will wait indefinitely for the trigger.
- e. All programs that produce a numeric result on the display (**Area**, **Frequency**, **Mean**, **Rise/Fall**, **RMS**, **Slope**, and **Standard Deviation**) also send their result to the selected interface (**RS-232** or **GPIB**). This allows you to easily record your results on a printer or computer. However, if the **GPIB** interface is selected, a computer must be connected and programmed to read the result or the instrument will appear to hang up as it waits for the computer's permission to transmit its result.

1. Execute START LEARNING.
The Start Learning screen appears (Figure 2).
2. Use the Up/Down cursor buttons to select whether you wish to create a new batch or append to the current batch.
3. Press the EXECUTE button. The instrument is now in LEARN mode, and all further operations will be stored as part of this batch.
4. To perform front panel operations such as HOLD NEXT, setting controls or plotting, press the Menu button. The instrument returns to the waveform display, but remains in Learn mode. All operations now performed will be stored in the batch.
5. To perform Menu operations such as waveform processing or recalling a setup, remain in (or return to) the menu. Move the cursor to the desired operation and press the Execute button. All operations executed will be stored in the batch.

Exception: Menu operations that are dimmed cannot be learned.

6. Repeat steps 4 and 5 as needed until the desired program has been learned. Then proceed to STOP LEARNING on the next page. An example batch might acquire two waveforms, multiply them together and plot the result.

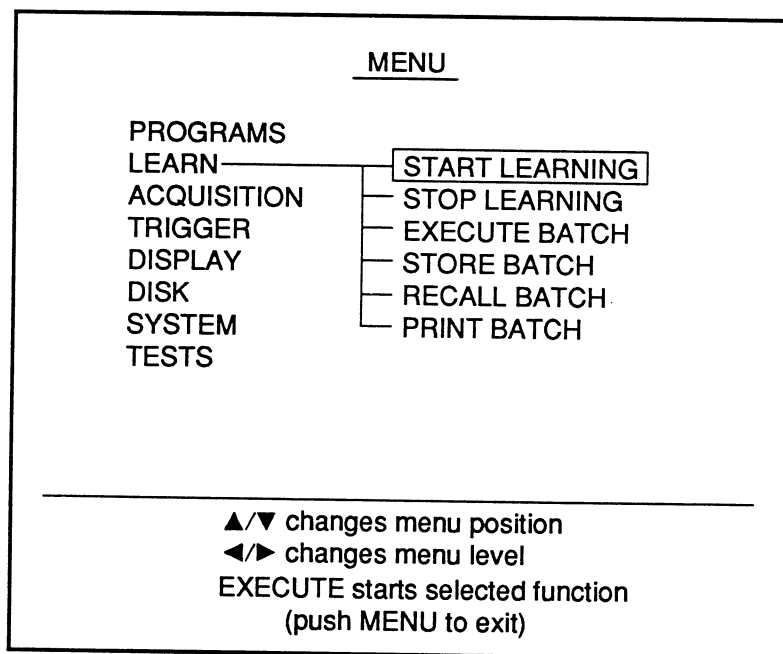

Figure 1 - Start Learning, Stop Learning and Execute Batch

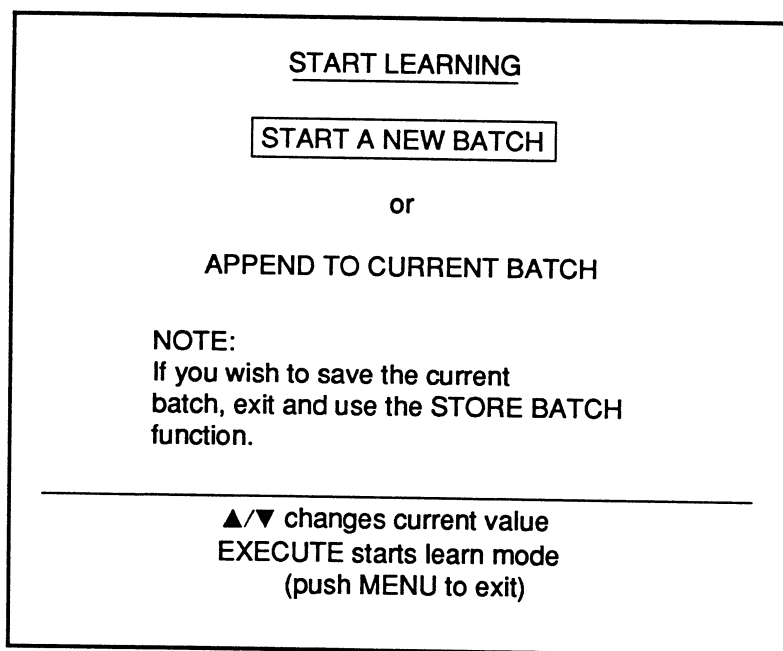

Figure 2 - Start Learning screen

STOP LEARNING, EXECUTE BATCH

Stop Learning

When the desired sequence of operations has been learned, return to the Learn menu. Select STOP LEARNING and press the Execute button.

The new batch of linked operations is now saved in memory for immediate use. It will remain available at the touch of a button until power is switched off or another batch is loaded from disk. The batch can also be stored on disk for later recall. See STORE BATCH on the next page.

Execute Batch

To run the batch, select EXECUTE BATCH and press the Execute button. You will be asked how many times to repeat the batch. The cursor buttons are used to set any number from 1 to 9,999. Finally, to execute the batch press the Execute button again.

Now that the batch has been executed once, it can be called repeatedly simply by touching the Execute button. It is not necessary to return to the menu.

While a batch is being executed, front panel controls are temporarily ignored. Control changes will take effect only after the batch has completed.

Aborting a Batch

If you wish to abort a long-running batch, simultaneously press the Hold Last and Execute buttons. This will interrupt a batch in progress.

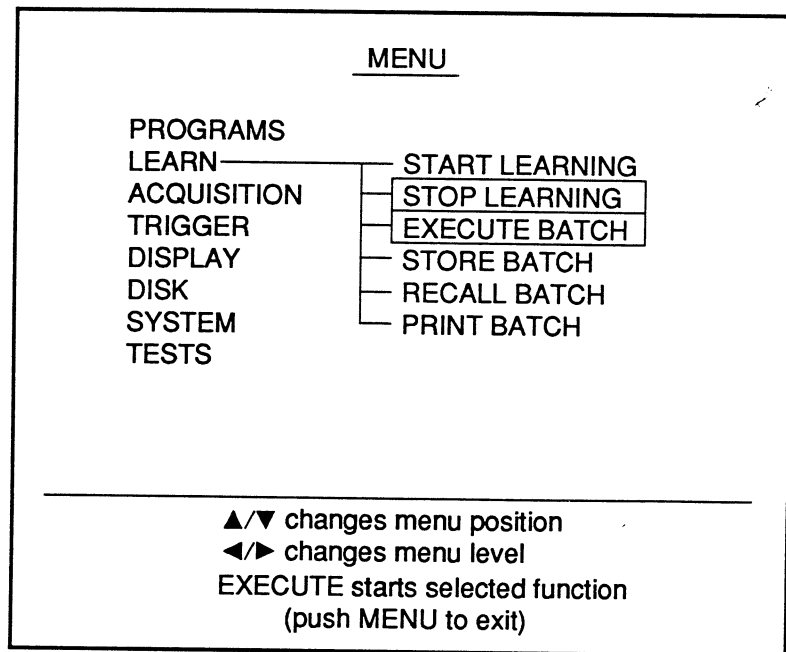

Figure 1 - Stop Learning and Execute Batch

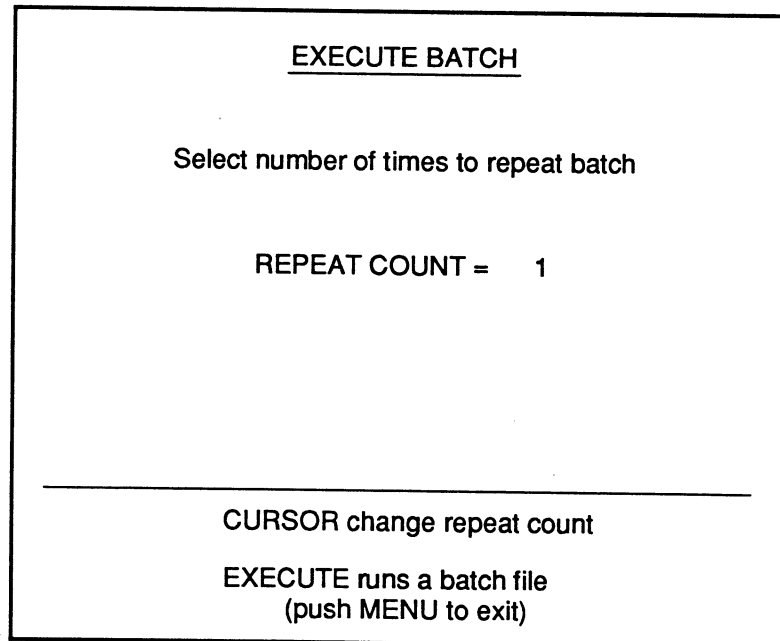

Figure 2 - Execute Batch screen

STORE BATCH, RECALL BATCH

Store Batch

Once a batch has been learned, it can be stored on disk for later recall.

1. Select STORE BATCH and press the Execute button.

Note: The Select button is used to change the function of the Cursor buttons between "CURSORS change file pointer" and "CURSORS change drive/path."

2. If the current drive or directory is not the one desired, press the Select button and then use the Cursor buttons to select the desired drive/path.
3. Use the Cursor buttons to select the desired file name and then press the Execute button to store the selected batch.

Recall Batch

A batch that has been learned and then stored on disk can be recalled for immediate use.

1. Select RECALL BATCH and press the Execute button.

Note: The Select button is used to change the function of the Cursor buttons between "CURSORS change file pointer" and "CURSORS change drive/path."

2. If the current drive or directory is not the one desired, press the Select button and then use the Cursor buttons to select the desired drive/path.
3. Use the Cursor buttons to select the desired file name and then press the Execute button to recall the selected batch.

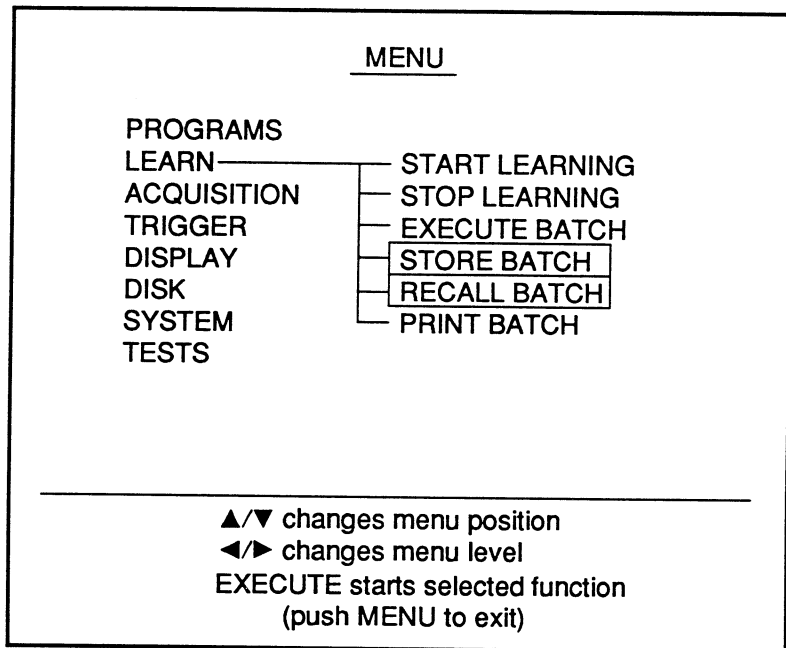

Figure 1 - Store Batch and Recall Batch

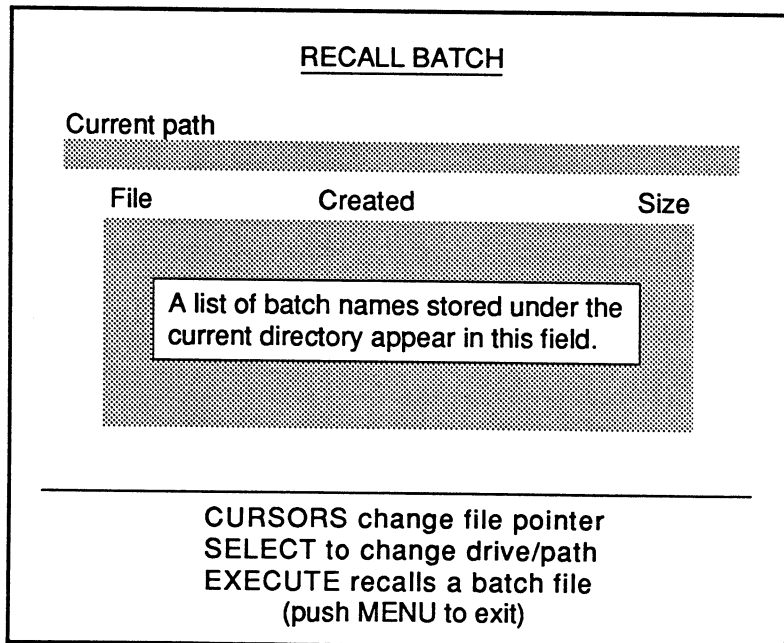

Figure 2 - Recall Batch screen

Batches and the PC

One of the most useful capabilities of the Nicolet instrument lies in its MS-DOS® compatible files. The batch files contain ASCII text which can be read by almost any word processor or text editor.

The text consists of "plain English" commands from the Nicolet IEEE-488.2 Remote Command Set. For example, a file containing the following text will cause the instrument to acquire signals, multiply two waveforms together, and put the new waveform in a reference memory:

```
:STORAGE:HOLDNEXT
:FUNCTION:MULTIPLY
CHANNEL1,CHANNEL2,REFERENCE1
```

MS-DOS compatibility brings several advantages to the batch files

1. The disk containing batch files from your instrument may be inserted directly into your PC and edited by your favorite word processor. You can easily inspect, modify or extend the batch files learned on the instrument. The text provides a fast learning tool for the instrument command set.
2. On your PC word processor, you can create custom analysis routines for the instrument. New batch files can be created in your office on the PC, then run in the field by the instrument.
3. Since the text of a batch file is identical to GPIB commands, the batch file can serve as a template for ATE programmers. Simply LEARN the desired procedure once on the instrument and save it in a batch file. Sending the same commands to the instrument via GPIB or RS-232 will duplicate their action. By processing the waveform data in the instrument and sending only the desired results to the computer, test throughput is multiplied.

Batch File Requirements

There are four requirements that you must follow when creating your own batch files on a PC.

1. Files may carry any legal DOS file name that is meaningful to you, but the extension ".SUB" must be used on all batch files. The instrument uses this extension to identify its batch files and to distinguish them from MS-DOS batch files.
2. Each command must be ASCII text conforming to IEEE-488.2. Refer to the separate Remote Command Sets Manual (Nicolet part number 269-9094xx) for complete definitions and examples.
3. Each command line must end with a carriage return/line feed.
4. If the instrument finds a file named HELLO.SUB in the root directory of its floppy or hard disk, it will automatically load and execute this batch file at power-up.

PRINT BATCH

Print Batch enables you to print a listing of the batch file stored in memory.

Before printing, confirm that your printer is connected properly. Either an RS-232 or a parallel (Centronics®) printer output can be selected via the PRINTER OUTPUT function located under the SYSTEM menu. The PRINTER OUTPUT function is described in *Chapter 22* of this manual.

1. When ready to print, select PRINT BATCH and press the Execute button.

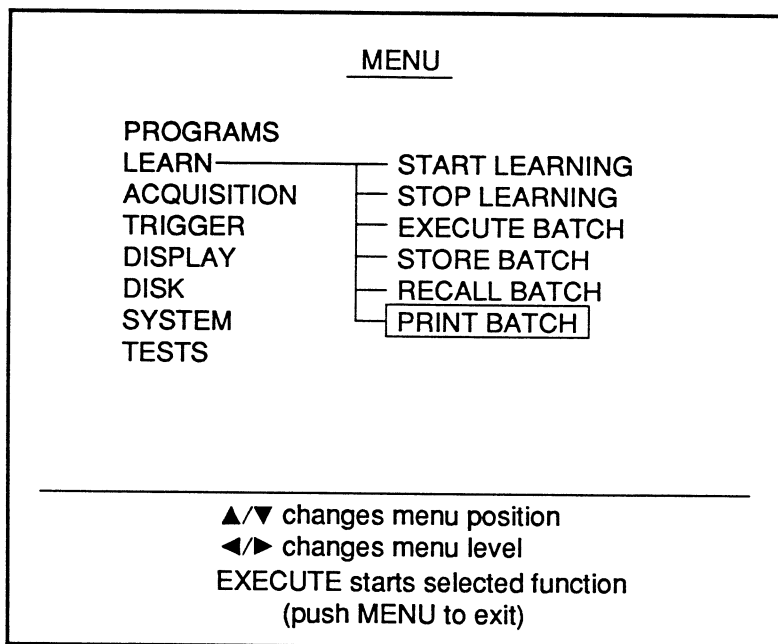

Figure 1 - Print Batch sample screen

Chapter 17

THE ACQUISITION

MENU

Sweep Length	17-2
Input Filters	17-4
Autocycle to Disk	17-5
Summation Average	17-9
Dual Sample Rates (Pro 90 Model only)	17-10

Acquisition allows you to change the sweep length, turn on or off the input filters, automatically store captured data on disk for later recall, average x-number of sweeps for display and capture data simultaneously for display using two dissimilar digitizer channels with different sampling rates.

Note: Dual Sample Rates is available only on the Pro 90 model.

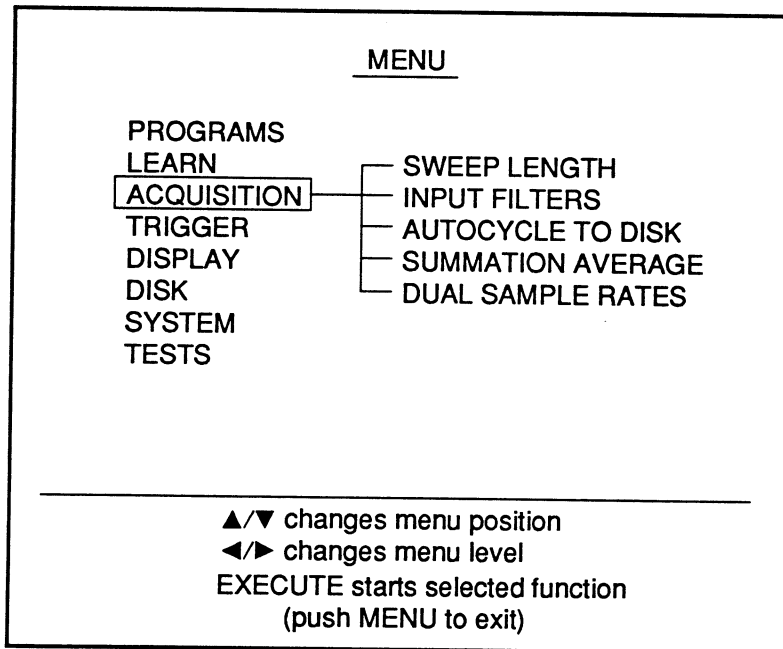

Figure 1 - The ACQUISITION Menu Display

SWEEP LENGTH

Sweep Length is used to select the number of data points that will be used to comprise one full sweep. See Chapter 10 for a description of the Sweep Length function.

MINIMUM and MAXIMUM show the ranges within which the sweep length can be set.

NEXT is used to enter the desired sweep length for the next sweep.

SAVE REF ALLOWED? locks the Save Ref button off when NO is entered by pressing the Select button. Allowing Save Ref reduces the number of archived sweeps by one.

'NEXT' VALUE ALLOWS: shows the maximum number of waveforms that can be stored in the Sweep Review Memory with the current settings on the Sweep Length screen.

Note: If you select the maximum sweep length for the next sweep, the instrument automatically defaults to "single-shot" operation only. That is, you must press the Hold Next button and wait for a valid trigger each time you wish to capture a new sweep. The "# archived sweeps per channel" field in Figure 2 will read '1 Shot acquisition only' if the maximum sweep length is selected. The small table in Figure 2 shows you the maximum values that can be entered as determined by whether or not Save Reference is allowed.

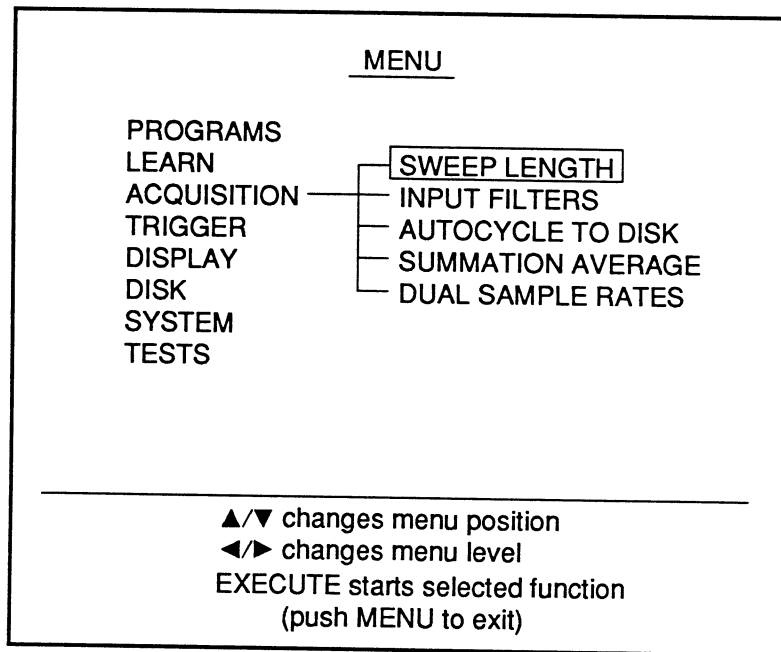

Figure 1 - Sweep Length

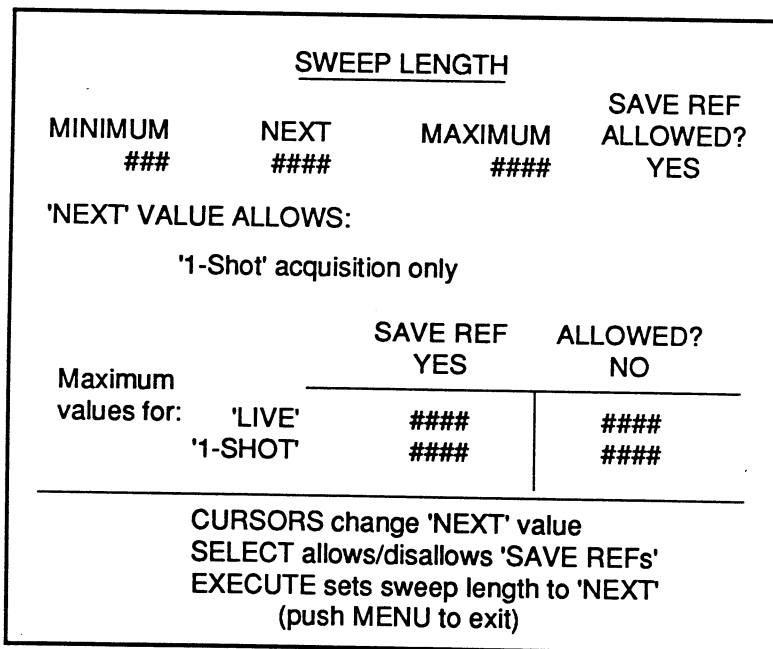

Figure 2 - Sweep Length parameter screen when the 'MAXIMUM' sweep length value is entered in the 'NEXT' field.

Changing the Sweep Length

1. Use the Cursor buttons to enter the new sweep length.
2. Use the Select button to enable or disable SAVE REFS.
3. Press the Execute button. A second screen will appear warning you that the waveform memory will be nulled if the Execute button is pressed.
4. Either press the Execute button to execute the new Sweep Length setting and clear the memory or press the Menu button to exit the Menu mode.

CAUTION: Pressing Execute will erase all of the previously captured data stored in memory when the warning screen in Figure 3 is present.

Calculating the Sweep Time

To determine the length of time it will take to complete one full sweep, either

- a. Bring up the Status display by pressing the front panel Status button and reading the sweep time directly from the screen (see *Chapter 13*, Status button).
- b. Multiply the value displayed below the NEXT field by the front panel Time readout setting.

For example, if the sweep length is set for 1000 and the Time readout is set for 2 μ S, then the next sweep will collect 1000 data points in 2 mS.

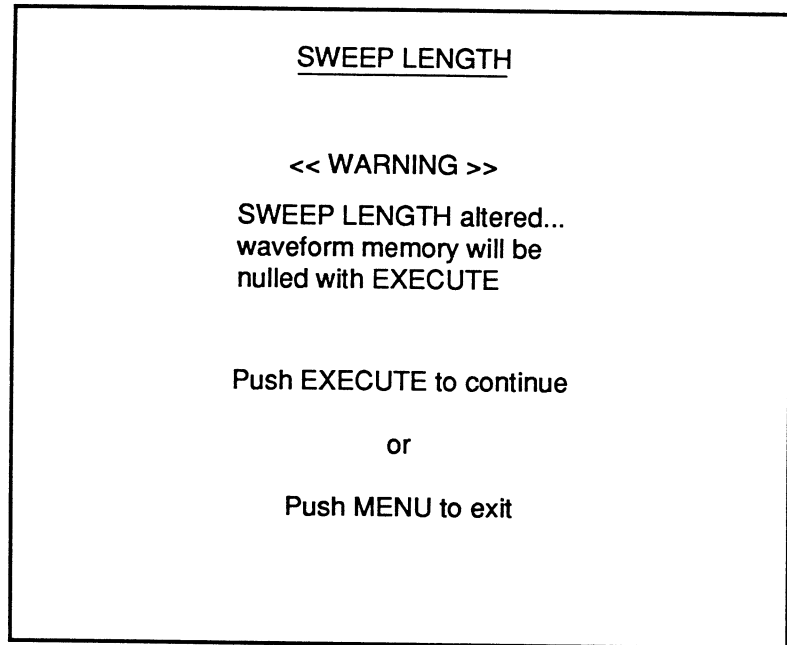

Figure 3 - Sweep Length warning screen

INPUT FILTERS

Input Filters allows you to turn the input filters on or off before capturing new signals.

External Input BNC

The **EXTERNAL** input BNC field will display the following options when the Left or Right Cursor buttons are pressed repeatedly:

- **Off** = Filter(s) is turned off.
- **Low** = 10 kHz
- **High** = 1 MHz
- **Hi/Lo** = 1 MHz and 10 kHz

1. Execute **INPUT FILTERS**.
2. Select **EXTERNAL** and use the Left or Right Cursor buttons to toggle through the choices.
3. When all selections have been entered, press the Execute button.

Channel Input BNCs

The **CHANNEL "#"** input BNC fields will display the following options when the Left or Right Cursor buttons are pressed.

- **Off** = Filter is turned off.
- **High** =
12-bit digitizers = 100 kHz
8-bit digitizers = 20 MHz

1. Execute **INPUT FILTERS**.
2. Select the channel(s) and use the Left or Right Cursor buttons to enable/disable the filter(s).
3. When all selections have been entered, press the Execute button.

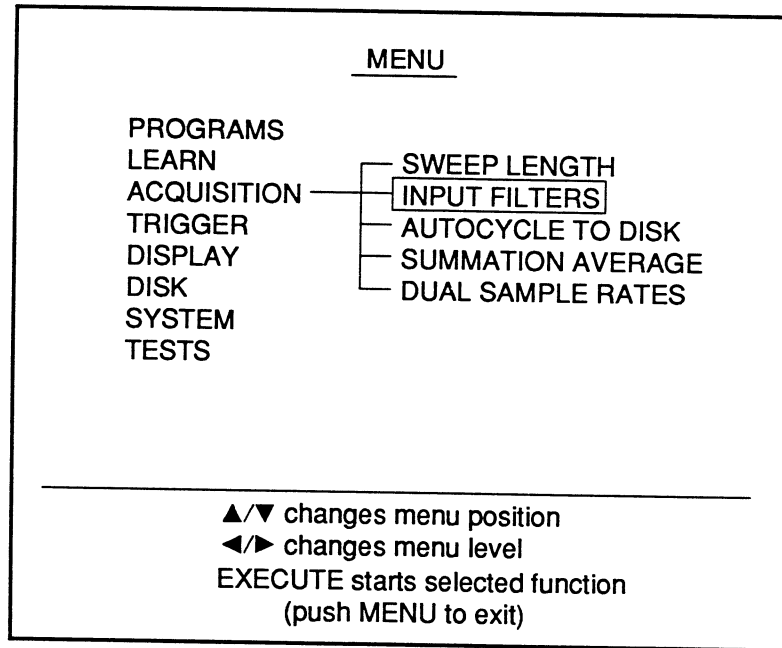

Figure 1 - Input Filters

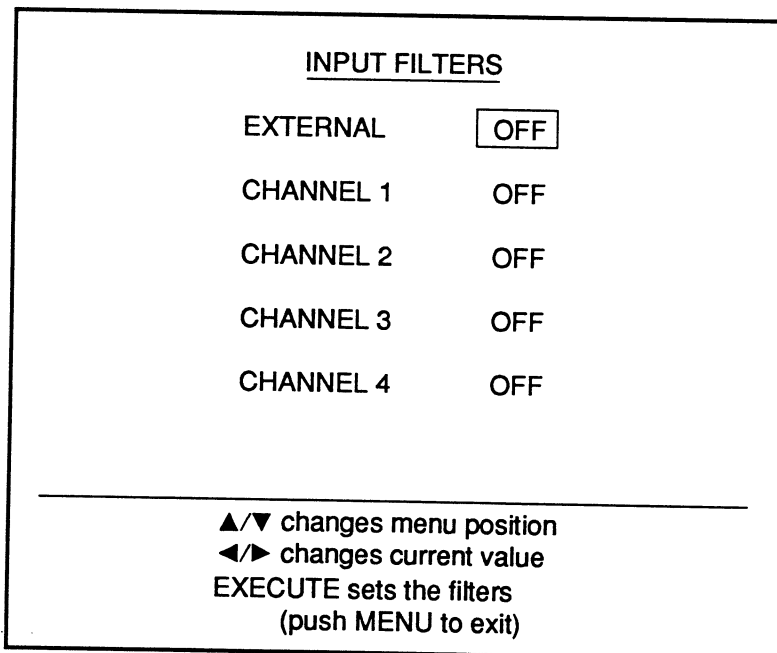

Figure 2 - Input Filters parameter screen

AUTOCYCLE TO DISK

Autocycle To Disk automatically captures and stores to disk all of the sweeps captured during each cycle. You must select a starting file name, the number of cycles you want the instrument to capture and the number of sweeps that will constitute each cycle. Refer to *pages 17-7 and 17-8* for examples.

CAUTION: Duplicate files on the disk are written over when the Autocycle to Disk function is executed.

Important: The root directory of a drive can only contain a maximum of 512 files and/or subdirectories. Therefore, store all files under subdirectories. This allows you to store as many files as you wish until the memory limit is reached. For example, you can only store a maximum of 512 files under the root directory (if no subdirectories exist). If you store the files under subdirectories, the number of files you can store is limited only by the available memory. This is typically more beneficial when using a hard disk or Bernoulli cartridge.

1. Execute **AUTOCYCLE TO DISK**. The Starting File name screen appears (Figure 2).
2. Select the desired drive/path using the Cursor buttons.

Note: The Select button is used to determine whether the cursor buttons will change the "drive/path" or the "file number." If necessary, press the Select button until "CURSORS change drive/path" appears towards the bottom of the screen.

Continued on the next page.

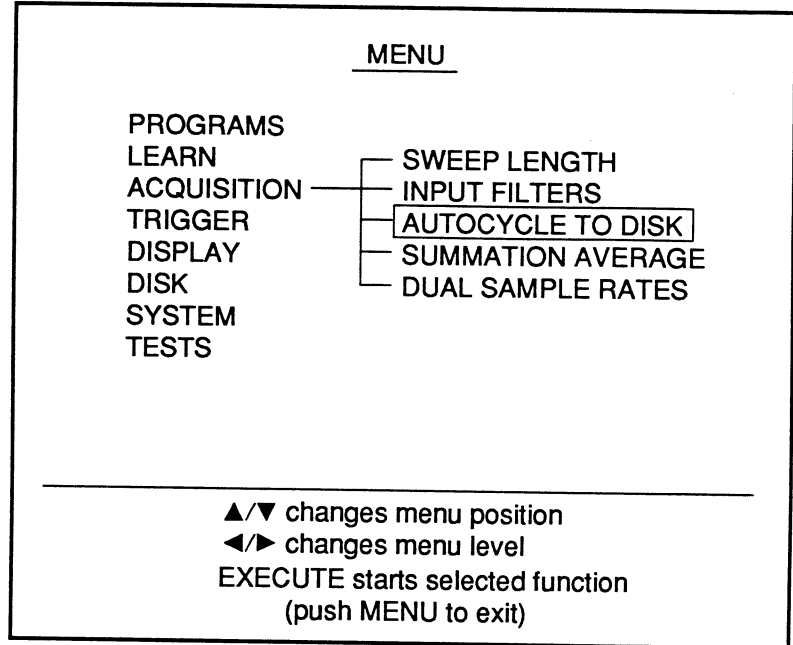

Figure 1 - Autocycle to Disk

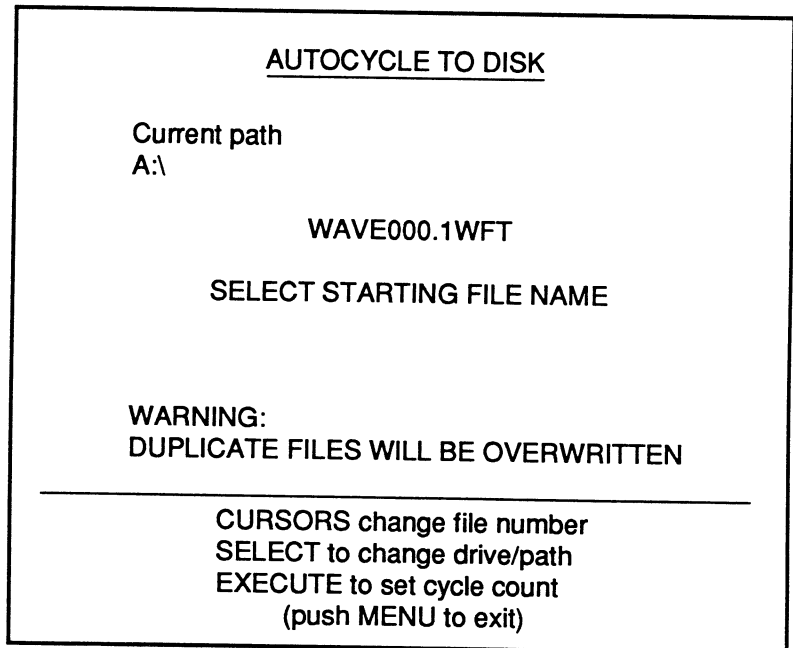

Figure 2 - Starting File Name selection screen

Autocycle To Disk cont.

3. Press the Select button until the screen reads "CURSORS change file number" as shown in Figure 2 and then select the desired starting file name using the Up/Down Cursor buttons.

The disk automatically increments to the next file name after each cycle of sweeps is stored to disk. For example, if the starting file name is WAVE0012.WFT and you wish to store two cycles to disk, the first cycle 1 will be stored in file name WAVE0012.WFT and the second cycle will be stored in file name WAVE0013.WFT.

4. Press the Execute button. The Number Of Cycles and Sweeps Per Cycle selection screen appears (Figure 3).

The next two steps define how many cycles you want the instrument to capture and how many sweeps will constitute a cycle.

5. Use the Left or Right Cursor button to position the selection box under NUMBER OF CYCLES and then the Up or Down Cursor button to enter the desired number of cycles.
6. Press the Left or Right Cursor button to position the selection box under SWEEPS PER CYCLE and then the Up or Down Cursor button to enter the desired number of sweeps per cycle.

AUTOCYCLE TO DISK

Path - A:\WAVE0012.WFT

NUMBER OF CYCLES	SWEEPS PER CYCLE
<div style="border: 1px solid black; display: inline-block; padding: 2px 10px;">2</div>	3

Free disk space for #### cycles

WARNING:
DUPLICATE FILES WILL BE OVERWRITTEN

CURSORS change values

EXECUTE to start autocycle
(push MENU to exit)

Figure 3 - With the above settings, the instrument will capture 2 cycles consisting of 3 sweeps each. It will store the first cycle under file name WAVE0012.WFT and the second cycle under WAVE0013.WFT.

7. Press the Execute button.

The instrument will arm itself automatically to capture the selected number of cycles. At the end of each cycle, the instrument goes into the Hold Last mode while the captured data is stored to disk. If this is not the last cycle, the instrument increments the file name by one and rearms itself for the next cycle. This is repeated until the last cycle has been completed and stored to disk, after which the instrument remains in the Hold Last mode. See examples on the next two pages.

Note: To cancel Autocycle, press any button on the front panel.

Continued on the next page.

Autocycle To Disk With One Channel Turned On

Figures 4 and 5 illustrate two examples of data being captured by a single channel and then stored to disk.

Figure 4 shows how individual sweeps can be stored under separate file names. Figure 5 shows how three sweeps can be stored under the same file name.

Note that in both examples, the instrument automatically increments to the next file name after the contents of each cycle has been stored to disk.

Also note in Figure 4 that the instrument always arms itself in the Hold Next mode because only one sweep is being captured per cycle.

Figure 5 arms itself in the Live mode for the first two sweeps of each cycle and then arms the Hold Next mode to capture the third and final sweep. If you are capturing data using very short sweep times, you may not be able to observe the transition from Live to Hold Next may be too quick to see.

Note: New sweeps cannot be triggered while the instrument is in the Hold Last mode.

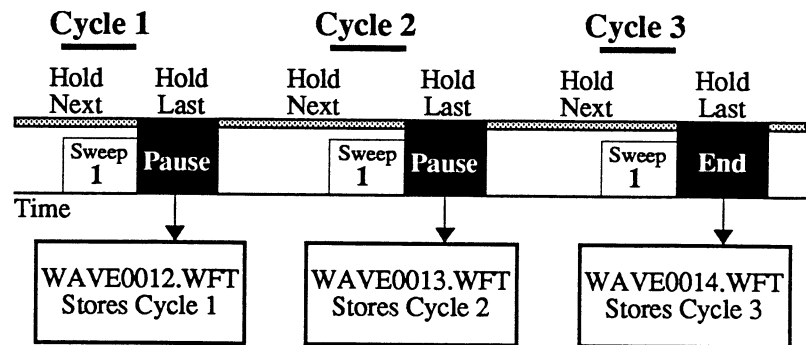

Figure 4 - Assume Starting File Name = WAVE0012.WFT, Number Of Cycles = 3, Sweeps Per Cycle = 1, One channel turned on.

Note that the instrument alternates between Hold Next (armed to capture a single sweep) and Hold Last (storing the captured data to disk). Also note that the file name increments by one after each cycle is stored to disk. When the third cycle is completed, the instrument remains in the Hold Last mode.

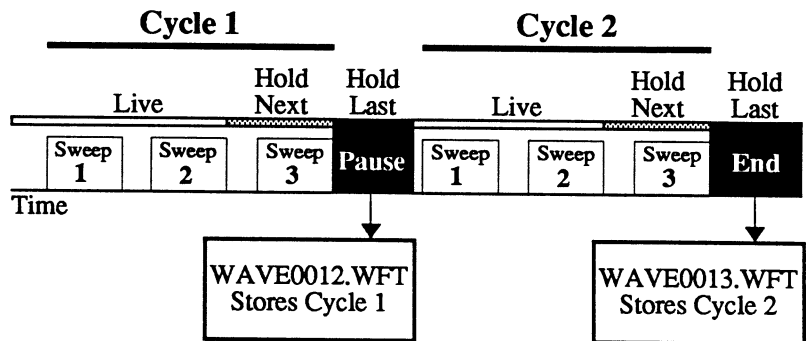

Figure 5 - Assume Starting File Name = WAVE0012.WFT, Number Of Cycles = 2, Sweeps Per Cycle = 3, One channel turned on.

Note that the instrument arms itself in the Live mode until the second sweep has been completed. At the end of the second sweep, the instrument automatically arms and remains in the Hold Next mode until the third sweep is completed. The instrument then enters the Hold Last mode, stores the captured data to disk, increments the file name by one and then rearms itself for the second cycle. At the end of the last cycle, the captured data is stored to disk and the instrument remains in the Hold Last mode.

Continued on the next page.

Autocycle To Disk with Multiple Channels Turned On

Figures 6 and 7 illustrate two examples of data being captured by two channels simultaneously and then stored to disk. The basic operation remains the same if you have three or four channels capturing data, however, it will take more waveform files to store each of the channels' captured data to disk.

Figure 6 shows how individual sweeps are stored under separate file names when only one sweep per channel is captured during each cycle. Figure 7 shows how the three sweeps captured by channel 1 is stored under one file name and then the three sweeps captured by channel 2 during the same cycle is stored under the next incremented file name.

Note that in both examples, the instrument automatically increments to the next file name after each channel's data is stored to disk.

Also note in Figure 6 that the instrument always arms itself in the Hold Next mode because only one sweep per channel is being captured per cycle.

Figure 7 arms itself in the Live mode for the first two sweeps of each cycle and then arms the Hold Next mode to capture the third and final sweep. If you are capturing data using very short sweep times, you may not be able to observe the transition from Live to Hold Next may be too quick to see.

Note: New sweeps cannot be triggered while the instrument is in the Hold Last mode.

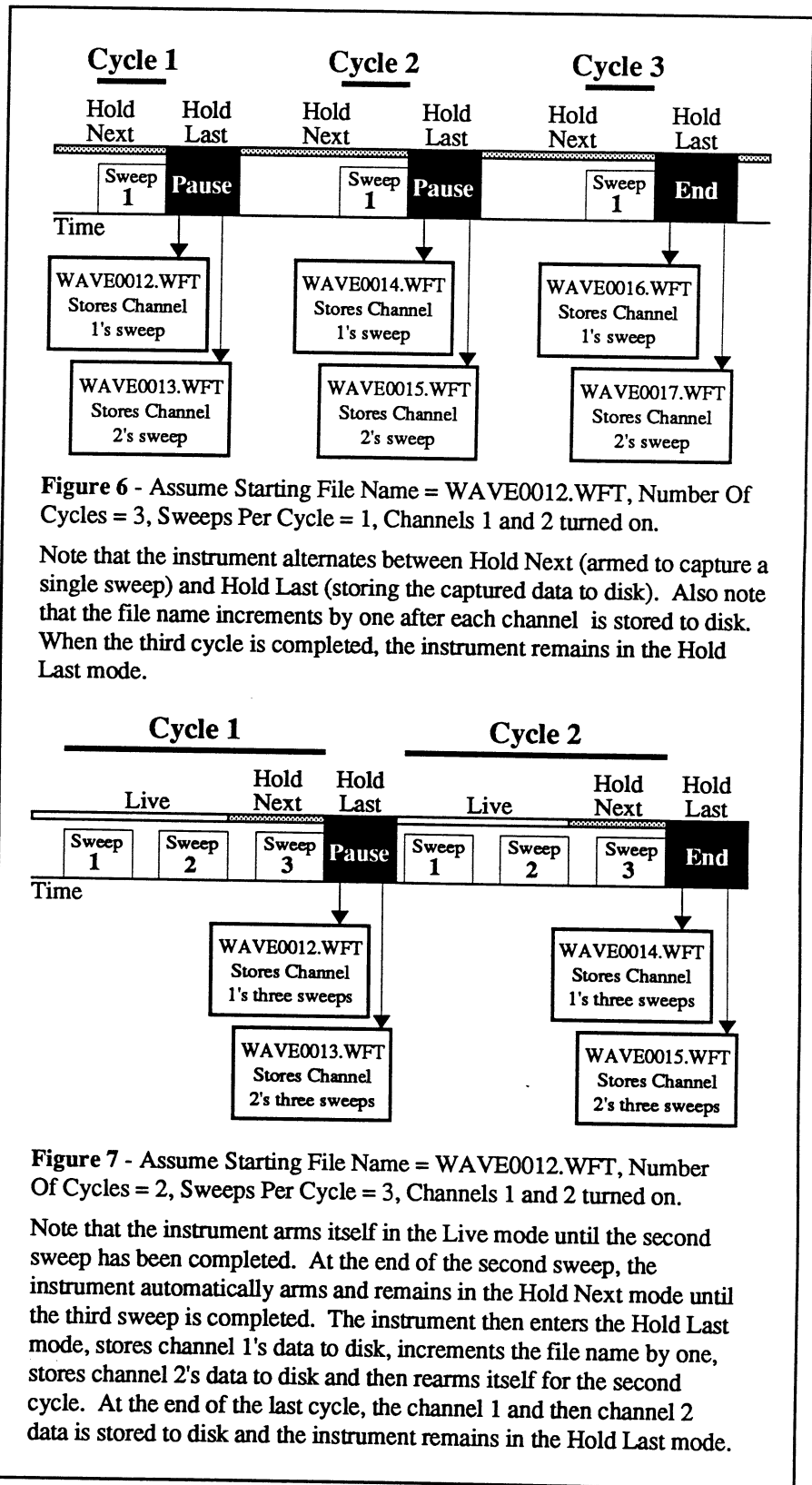

Figure 6 - Assume Starting File Name = WAVE0012.WFT, Number Of Cycles = 3, Sweeps Per Cycle = 1, Channels 1 and 2 turned on.

Note that the instrument alternates between Hold Next (armed to capture a single sweep) and Hold Last (storing the captured data to disk). Also note that the file name increments by one after each channel is stored to disk. When the third cycle is completed, the instrument remains in the Hold Last mode.

Figure 7 - Assume Starting File Name = WAVE0012.WFT, Number Of Cycles = 2, Sweeps Per Cycle = 3, Channels 1 and 2 turned on.

Note that the instrument arms itself in the Live mode until the second sweep has been completed. At the end of the second sweep, the instrument automatically arms and remains in the Hold Next mode until the third sweep is completed. The instrument then enters the Hold Last mode, stores channel 1's data to disk, increments the file name by one, stores channel 2's data to disk and then rearms itself for the second cycle. At the end of the last cycle, the channel 1 and then channel 2 data is stored to disk and the instrument remains in the Hold Last mode.

SUMMATION AVERAGE

Summation Average allows the instrument to capture and summation average x-number of sweeps.

Select the Live mode to continually capture a new series of sweeps or select Hold Next to capture only one set of sweeps at a time. The result at the end of each series is stored in the Sweep Review Memory. Artifact Reject rejects any sweeps with events exceeding the display limits of the screen (e.g., large noise spikes, etc.).

1. Execute **SUMMATION AVERAGE**.
2. Use the **CURSOR** buttons to enable Averaging Function and, if desired, Artifact Reject. Next, use the **CURSOR** buttons to select Sweeps Summed and enter the desired number of sweeps (Figure 2). The minimum is 2 and the maximum is 65535 sweeps.
3. In the Summation Waveform field, select whether you wish to view the summed waveform after each sweep or only after all of the sweeps have been summed.
4. In the Summation Count field, select whether a counter will be displayed showing which sweep is being captured.
5. Press the **EXECUTE** button. A **WARNING** screen will appear.

CAUTION: Pressing the **EXECUTE** button to continue will **null all data stored in the Sweep Review Memory**. If you wish to save that data to disk before it is lost, press the **MENU** button, save the data to disk and then repeat the above procedure.

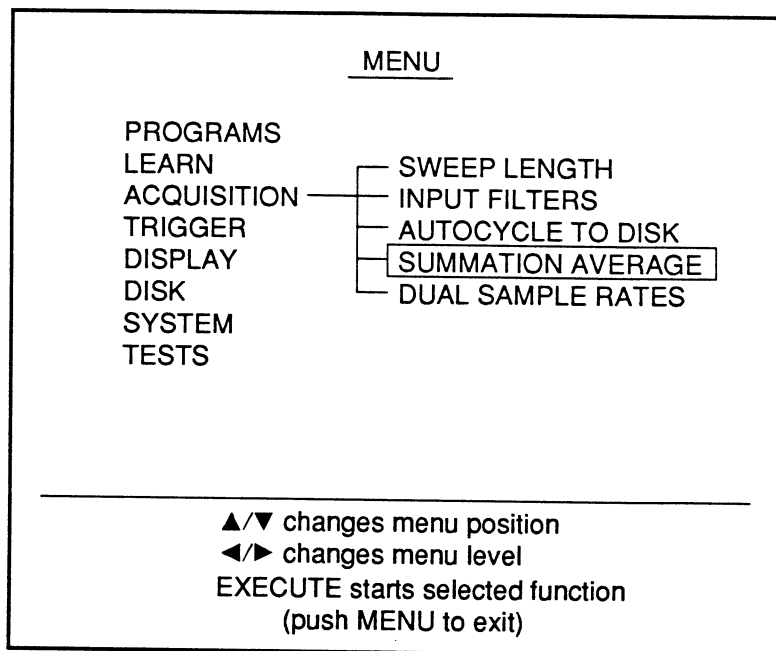

Figure 1 - Summation Average

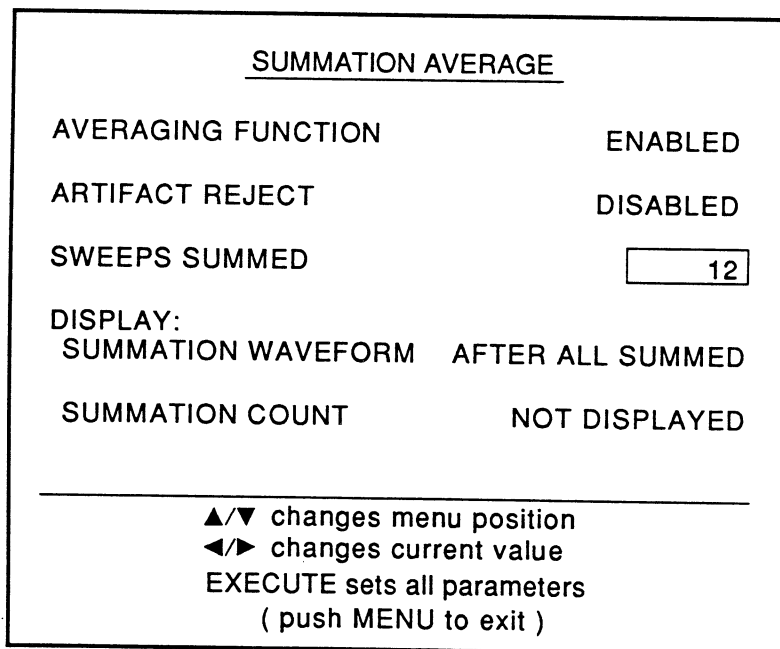

Figure 2 - Summation Average parameters screen

DUAL SAMPLE RATES

Dual Sample Rates allows the Nicolet Pro 90 Model to simultaneously capture input signals sampled at two different rates. This dual timebase feature allows you to capture and observe both slow and fast events simultaneously.

For example, you can simultaneously capture up to two signals with the 8 bit, 200 MHz digitizer channels and up to two signals with the 12 bit, 10 MHz digitizer channels.

Note: Channels 1 and 2 always have identical Time Per Point settings. Likewise, channels 3 and 4 always share identical Time Per Point settings. For example, if you set channel 1 to 1.0 μ S, then channel 2 will also be set to 1.0 μ S.

1. Execute DUAL SAMPLE RATES.
2. Press the Execute button. The Dual Sample Rates execution screen appears (Figure 2).
3. Press the Execute button. The waveform display returns.
4. Turn on the channels with which you want to capture input signals. You now can set the Time Per Point for the enabled channels as described on the next page.

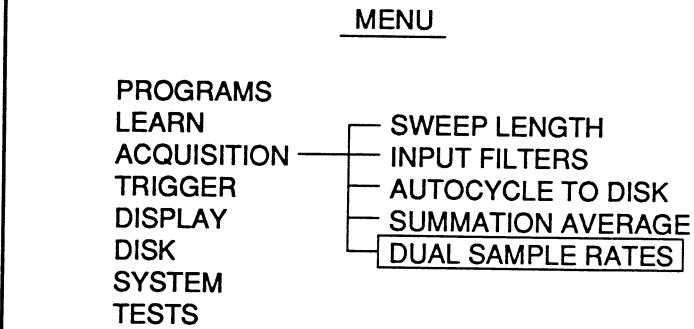

▲/▼ changes menu position
 ◀/▶ changes menu level
 EXECUTE starts selected function
 (push MENU to exit)

Figure 1 - Dual Sample Rates is available on the Pro 90 Model only.

DUAL SAMPLE RATES

DUAL SAMPLE RATES, when enabled, allows each digitizer type to have its own sampling rate. Once enabled, change the rate by SELECTing the desired channel and then use the TIME knob.

Push EXECUTE to enable

or

Push Menu to exit

Figure 2 - Dual Sample Rates execution screen

5. To set the Time Per Point value for channels 1 and 2, highlight the left value (Figure 1) by pressing the Select button and then adjusting the Time control knob until the desired setting appears.
6. To set the Time Per Point value for channels 3 and 4, highlight the right value by pressing the Select button and then adjusting the Time control knob.
7. Generally, if you are not using External triggering, select the channel with the fastest Time Per Point setting as the trigger source.

For example, if you set channel 1 to 500 nS and channel 3 to 1.0 μ S, select channel 1 as the trigger source.

You can read time and voltage values directly from the numerics in the normal manner by pressing the Select button until the desired waveform is highlighted. The Time numerics will automatically reflect the corresponding Time Per Point setting that was used to capture the selected waveform.

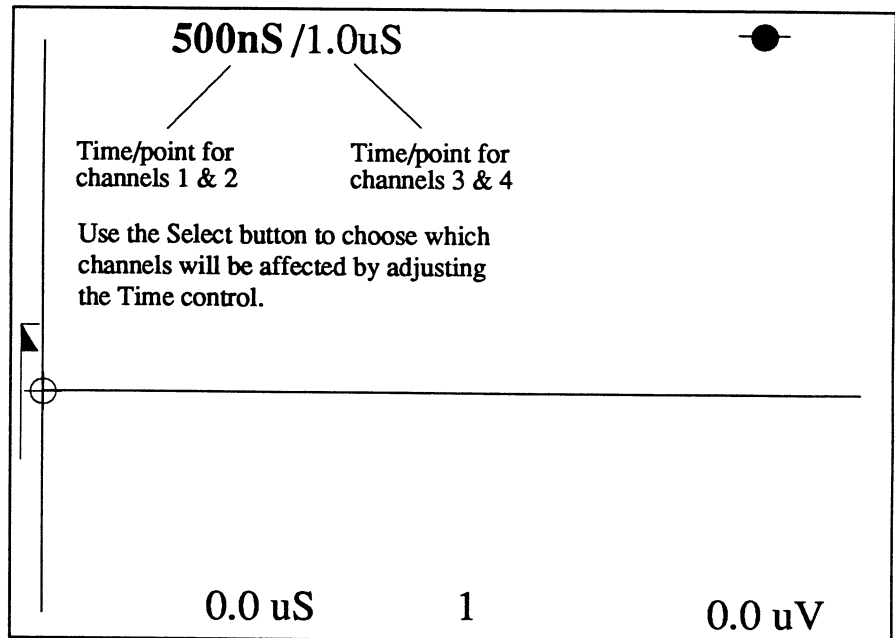

Figure 1 - The Time Per Point has been set to 500 nS for channels 1 and 2, and 1.0 μ S for channels 3 and 4 in this example. Use the Select button to choose which pair of channels will be set when you adjust the Time control.

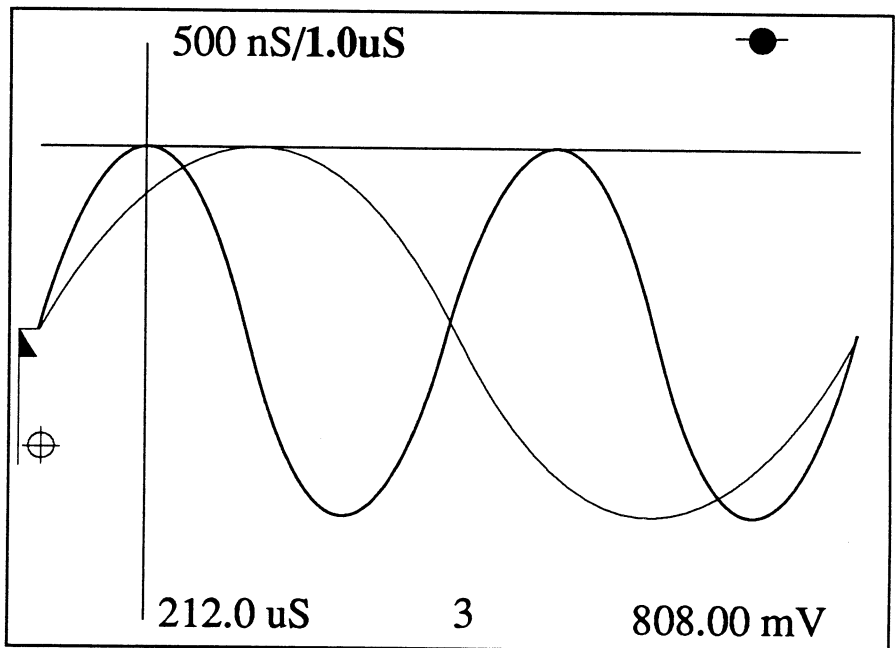

Figure 2 - Two identical signals were input to channels 1 and 3 with the Time Per Point settings shown. Channel 1 captured one full cycle while channel 3 captured two full cycles with its Time Per Point setting of 1.0 μ S.

Chapter 18

THE TRIGGER

MENU

Defining Pulse Widths & Intervals	18-2
Glitch Triggering	18-3
Dropout Triggering	18-6
Hold Off Triggering	18-9
n-Event Triggering	18-12
Adv Triggering	18-15
Cursor Time Lock	18-19
Independent Delays	18-21
'OR' Triggering	18-22
Level/Sens Lock	18-23
Master/Slave	18-24
Triggering Specifications	18-26

The Trigger menu allows you to select various triggering parameters that will be used to qualify a valid trigger to trigger a sweep. See page 18-26 for the trigger specifications.

Note: Glitch, Dropout, Hold Off, n-Event and Adv Triggering are mutually exclusive. Only one function can be enabled at a time. Also, attempting to combine 'OR' Triggering with any of the above five functions will result in either of the following two warning screens.

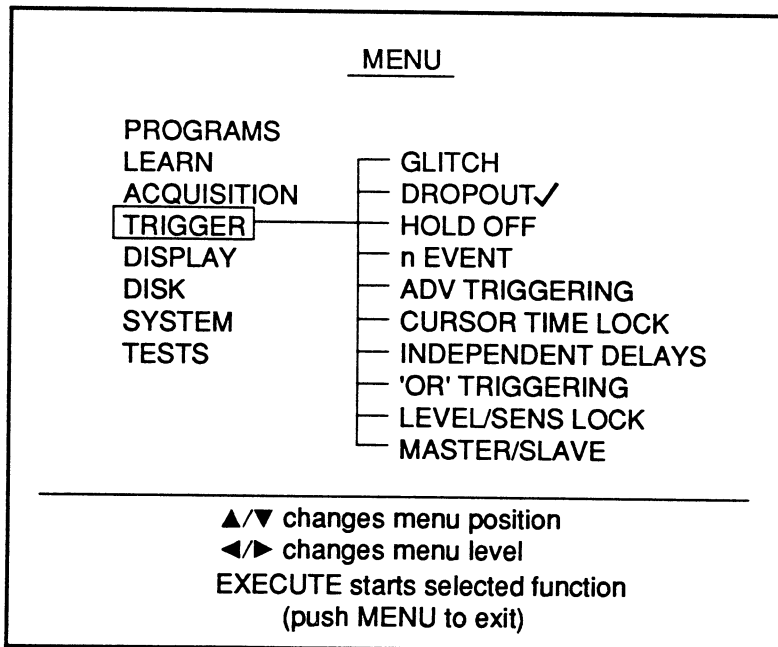

Figure 1 - Trigger menu. The check mark next to Dropout shows the function is already enabled.

```

'OR' TRIGGERING
WARNING!!!
HOLD OFF
is not allowed with this function
It will be disabled if you continue

Push EXECUTE to continue

or

Push MENU to exit
  
```

Figure 2 - Warning screen appears if you execute 'OR' Triggering while Glitch, Dropout, Hold Off, n Event or Adv Triggering is check marked.

```

GLITCH TRIGGERING
WARNING!!!
'OR' TRIGGERING
is not allowed with this function
It will be disabled if you continue

Push EXECUTE to continue

or

Push MENU to exit
  
```

Figure 3 - Warning screen appears if you execute Glitch, Dropout, Hold Off, n Event or Adv Triggering while 'OR' Triggering is check marked.

DEFINING PULSE WIDTHS

A pulse width is the distance in time between two qualifying events of the selected triggering signal. Which features will qualify as valid events are determined by the selected trigger slope:

- Positive Slope: see Figure 1.
- Negative Slope: see Figure 2.
- Dual Slope: for Adv Triggering only.

Trigger Specifications

The triggering specifications for Glitch (page 18-5), Dropout (18-8), Hold Off (18-11) and n Event (18-14) are summarized on page 18-26 for comparison. These values are not applicable for Adv Triggering.

DEFINING INTERVALS

An interval is the distance in time between two qualifying events of the selected triggering signal. Which features will qualify as valid events are determined by the selected trigger slope:

- Positive Slope: see Figure 3.
- Negative Slope: see Figure 4.
- Dual Slope: for Adv Triggering only.

Trigger Specifications

The triggering specifications for Glitch (page 18-5), Dropout (18-8), Hold Off (18-11) and n Event (18-14) are summarized on page 18-26 for comparison. These values are not applicable for Adv Triggering.

Pulse Width

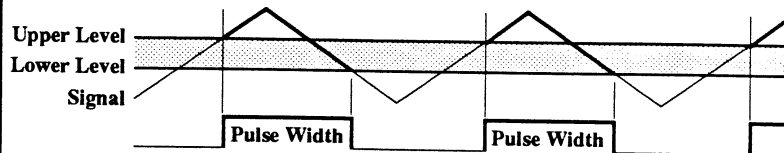

Figure 1 - When Positive Slope triggering is used, the Pulse Width is the time span between the rising and falling edges of the triggering signal.

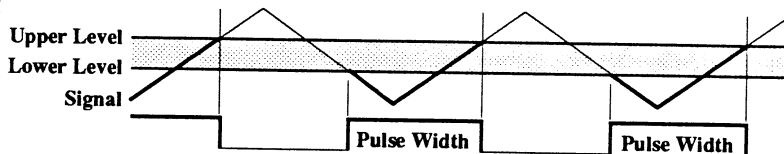

Figure 2 - When Negative Slope triggering is used, the Pulse Width is the time span between the falling and rising edges of the triggering signal.

Interval

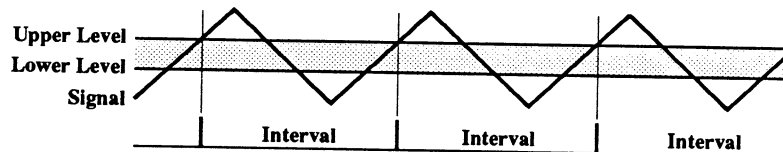

Figure 3 - When Positive Slope triggering is used, the Interval is the time span between two qualified rising edges of the selected signal.

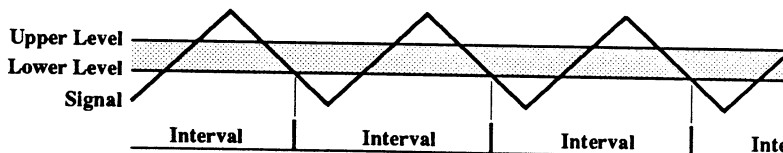

Figure 4 - When Negative Slope triggering is used, the Interval is the time span between two qualified falling edges of the selected signal.

GLITCH TRIGGERING

Glitch Triggering requires two qualified events to trigger a sweep. The first event starts a user-defined timer. If the second event occurs before the timer times out, a sweep is triggered.

Glitch Triggering can be executed either by the front panel controls or by the remote control commands.

Front Panel Operation

Front panel operation provides Pulse Width triggering.

Remote Control Operation

Remote control operation provides Interval or Pulse Width triggering.

See your Nicolet Remote Command Set manual (p/n 269-9094xx) for more information.

The Triggering Signal

Input the triggering signal to the External input BNC or to one of the installed channel's input BNCs. Use the trigger Source button to match your selection.

Note: 'OR' triggering is not allowed with Glitch triggering. In addition, the Glitch, Dropout, Hold Off, n Event and Adv Triggering are mutually exclusive. Only one can be enabled at a time.

Making Time Measurements

All time measurements are made with respect to the trigger time (t=0) origin.

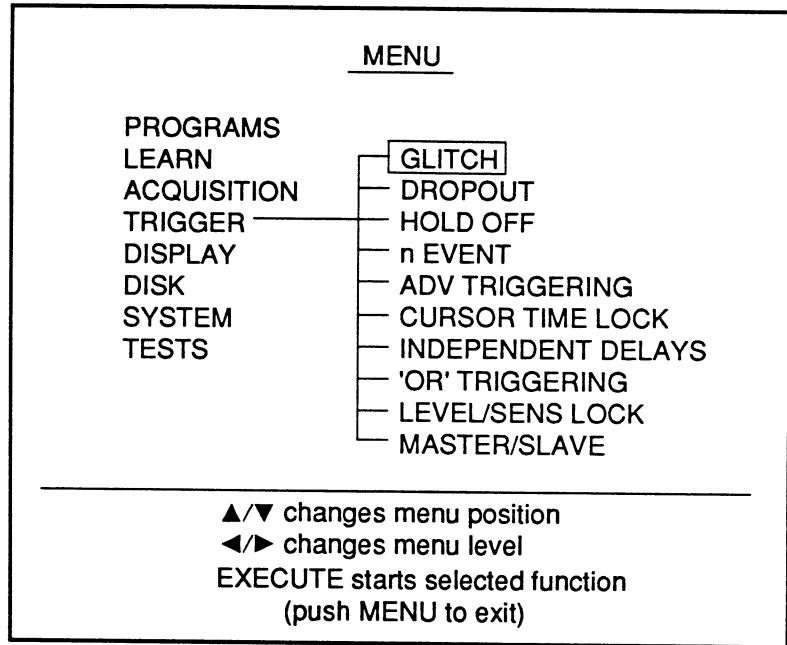

Figure 1 - Glitch triggering is selected.

Examples

Figures 1 and 2 illustrate signals which start user-defined timers. A sweep is triggered if a qualifying event occurs too soon and resets the timer before the timer can time out.

Note: Positive Slope triggering is used for both examples.

Figure 1: Glitch-Pulse

With **positive slope triggering** selected, the timer is started by qualifying negative slope events. If a qualifying positive slope event occurs before the timer times out, a sweep is triggered.

With **negative slope triggering**, positive slope events start the timer and negative slope events reset the timer.

Figure 2: Glitch-Interval

With **positive slope triggering** selected, the timer is started and reset by qualifying positive slope events only. If the timer is reset by a qualifying positive slope event before the timer times out, a sweep is triggered.

With **negative slope triggering**, only negative slope events can start and reset the timer.

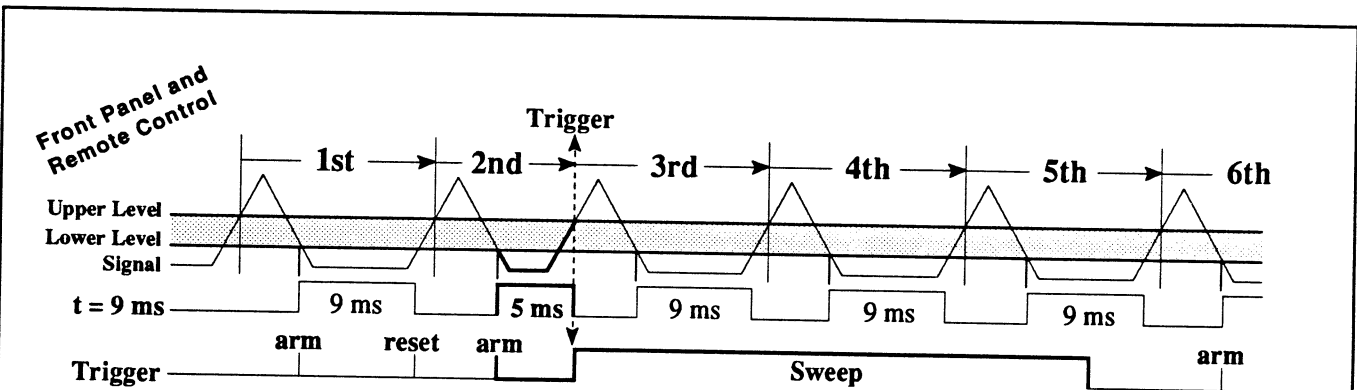

Figure 1 - Glitch-Pulse - The timer is set to 9 ms. The negative slope event in the 1st cycle starts the timer, but it times out before a sweep is triggered. The timer starts again in the 2nd cycle, but this time the positive slope event at the start of the 3rd cycle occurs too soon and resets the timer after only 5 ms and triggers a sweep. This example illustrates positive slope triggering.

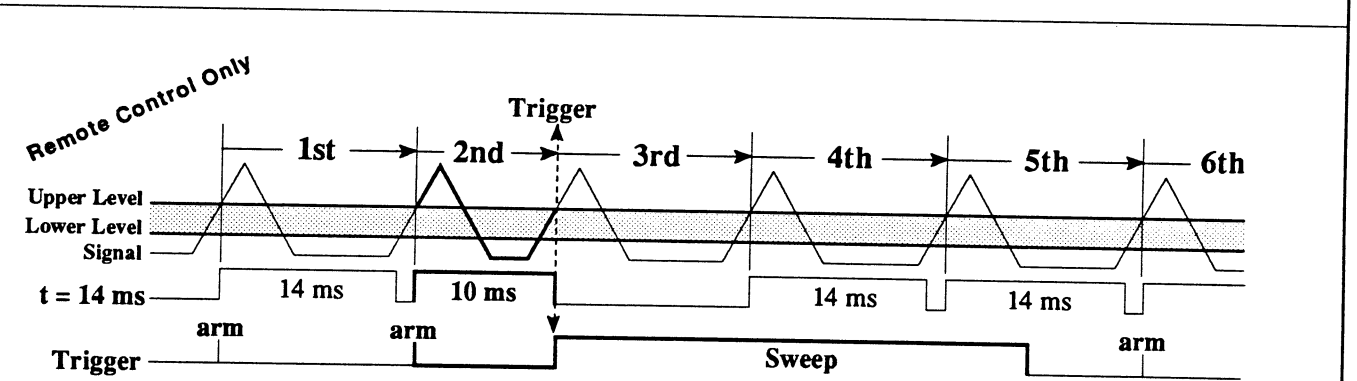

Figure 2 - Glitch-Interval - The timer is set to 14 ms. The positive slope event at the beginning of the 1st cycle starts the timer, but it times out before a sweep is triggered. The timer starts again at the beginning of the 2nd cycle, but this time the positive slope event at the start of the 3rd cycle occurs too soon and resets the timer after only 10 ms and triggers a sweep.

Setting the Glitch Function

1. Press the Menu button. The Menu display appears.
2. Using the cursor buttons, select the Trigger menu and then press the Execute button.
3. Using the cursor buttons, select 'Glitch' and then press the Execute button.
4. Press the trigger Source button until the desired source appears.
5. Press the trigger Slope button until the desired slope appears.
6. Press the "Level/Sens, Time/Count" button until the Time/Count LED lights.
7. Adjust the trigger Time/Count control knob until the desired value "n" appears on the screen.
8. When ready, press Execute to return to the waveform display.

Disabling the Glitch Function

Note: To disable Glitch triggering, select 'Glitch' on the Trigger Menu display and press the Execute button to remove the check mark. Glitch triggering is disabled automatically if you enable Dropout, Hold Off, n Event or Adv Triggering.

Source Button
Slope Button
Time Control

CURSOR changes menu position/value
 TIME/COUNT knob changes time
 EXECUTE sets values
 (push MENU to exit)

Figure 1 - Positive slope triggering is selected and the trigger source is set for the External input BNC. A sweep will trigger if a qualified event occurs before the 999.2 μ S timer times out.

GLITCH TRIGGER SPECIFICATIONS

All times are minimum values. Maximum value is 40 seconds.
 (Not applicable for Adv Triggering modes)

a. Pro 10, 20:	External = 20 ns, Channel = 3 μ s
b. Pro 30, 40:	External = 20 ns, Channel = 300 ns
c. Pro 50, 60:	20 ns
d. Pro 90:	External = 20 ns
	8-bit Channel = 20 ns
	12-bit Channel = 300 ns

DROPOUT TRIGGERING

Dropout Triggering requires two qualified events to trigger a sweep. The first event starts a user-defined timer. If the timer times out before the second qualified event occurs, a sweep is triggered.

Dropout Triggering can be executed either by the front panel controls or by the remote control commands.

Front Panel Operation

Front panel operation provides Interval Triggering.

Remote Control Operation

Remote control operation provides Interval or Pulse Width triggering.

See your Nicolet Remote Command Set manual (p/n 269-9094xx) for more information.

The Triggering Signal

Input the triggering signal to the External input BNC or to one of the installed channel's input BNCs. Use the trigger Source button to match your selection.

Note: 'OR' triggering is not allowed with Dropout triggering. In addition, the Glitch, Dropout, Hold Off, n Event and Adv Triggering are mutually exclusive. Only one can be enabled at a time.

Making Time Measurements

All time measurements are made with respect to the trigger time (t=0) origin.

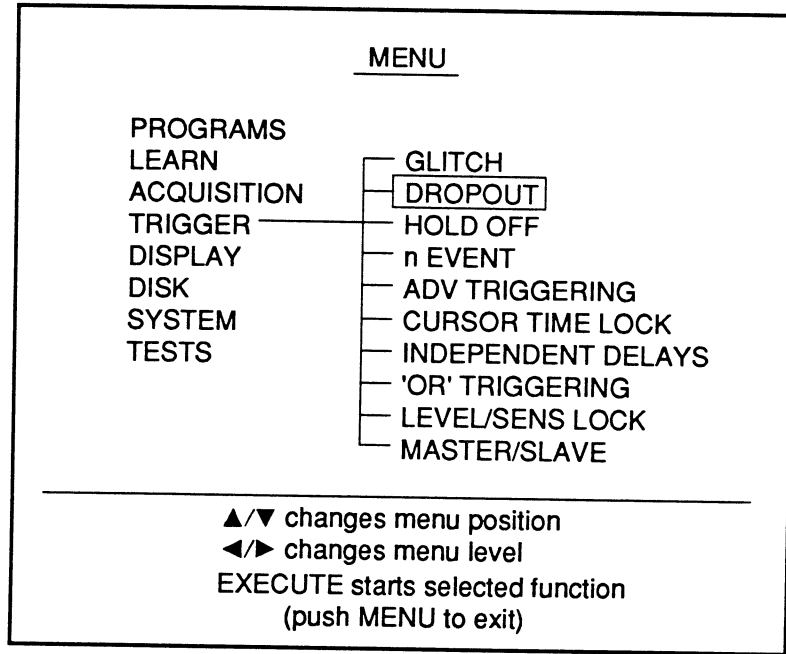

Figure 1 - Dropout triggering is selected.

Example

Figures 1 and 2 illustrate signals which start user-defined timers. A sweep is triggered if a qualifying event occurs too late and allows the timer to time out.

Note: Positive Slope triggering is used for both examples.

Figure 1: Dropout-Interval

With **positive slope triggering** selected, qualified positive slope events start and reset the timer. If the timer is not reset before it times out, a sweep is triggered.

With **negative slope triggering**, only negative slope events can start and reset the timer.

Figure 2: Dropout-Pulse

With **positive slope triggering** selected, a qualified negative slope event starts the timer and a positive slope event is required to reset the timer. A sweep is triggered if the timer is allowed to time out.

With **negative slope triggering**, a positive slope event starts the timer and a negative slope event is required to reset the timer.

Front Panel and Remote Control

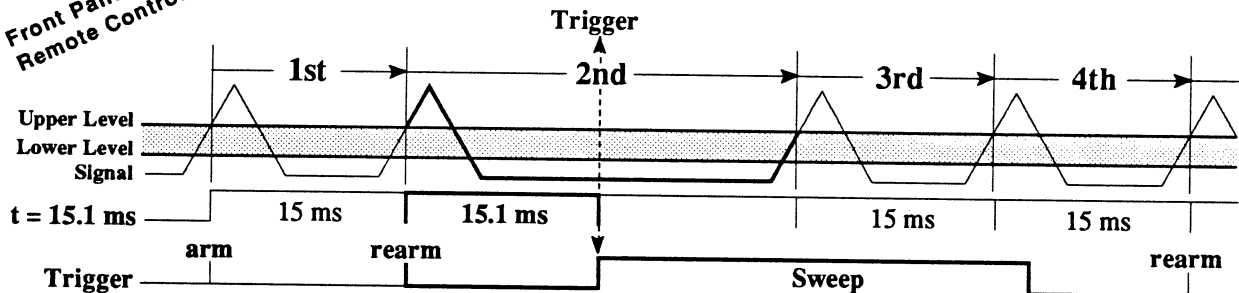

Figure 1 - Dropout-Interval - The timer is set to 15.1 ms. The **positive slope** event starts the timer in the 1st cycle but before the timer can time out, it is reset because the interval lasts only 15 ms. The timer is armed again at the start of the 2nd cycle, but this time it times out and triggers a sweep. This example illustrates positive slope triggering

Remote Control Only

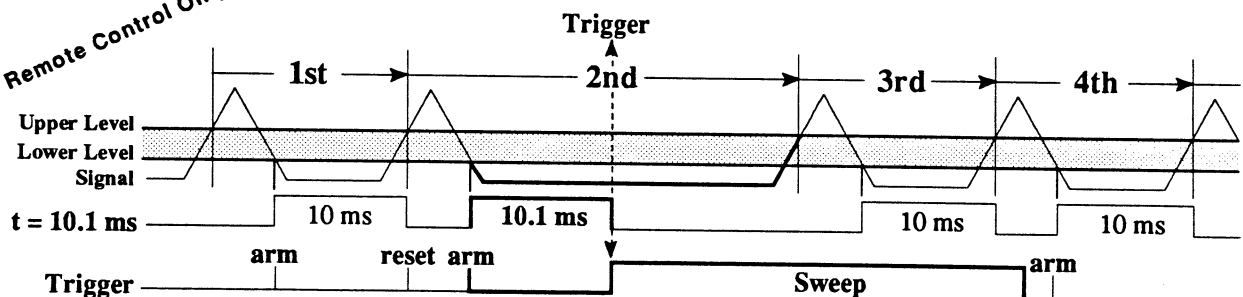

Figure 2 - Dropout-Pulse - The timer is set to 10.1 ms. The **negative slope** event starts the timer in the 1st cycle but before the timer can time out, it is reset because the interval lasts only 10 ms. The timer is armed again in the 2nd cycle, but this time it times out and triggers a sweep. This example illustrates positive slope triggering

Setting the Dropout Function

1. Press the Menu button. The Menu display appears.
2. Using the cursor buttons, select the Trigger menu and then press the Execute button.
3. Using the cursor buttons, select 'Dropout' and then press the Execute button.
4. Press the trigger Source button until the desired source appears.
5. Press the trigger Slope button until the desired slope appears.
6. Press the "Level/Sens, Time/Count" button until the Time/Count LED lights.
7. Adjust the trigger Time/Count control knob until the desired value "n" appears on the screen.
8. When ready, press Execute to return to the waveform display.

Note: To disable Dropout triggering, select 'Dropout' on the Trigger Menu display and press the Execute button to remove the check mark. Dropout triggering is disabled automatically if you enable Glitch, Hold Off, n Event or Adv Triggering.

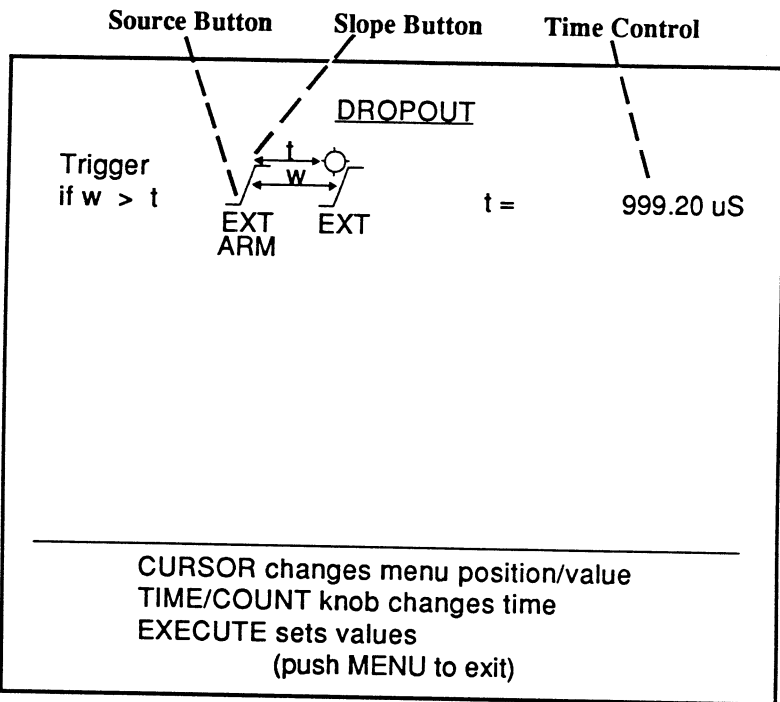

Figure 1 - Positive slope triggering is selected and the trigger source is set for the External input BNC. A sweep is triggered if the 999.2 μ S timer times out before it is reset by a qualified event.

DROPOUT TRIGGER SPECIFICATIONS

All times are minimum values. Maximum value is 40 seconds.
 (Not applicable for Adv Triggering modes)

- | | |
|----------------|---------------------------------------|
| a. Pro 10, 20: | External = 60 ns, Channel = 3 μ s |
| b. Pro 30, 40: | External = 60 ns, Channel = 300 ns |
| c. Pro 50, 60: | 60 ns |
| d. Pro 90: | External = 60 ns |
| | 8-bit Channel = 60 ns |
| | 12-bit Channel = 300 ns |

HOLD OFF TRIGGERING

Hold Off Triggering requires two qualified events. The first qualified event starts a user-defined timer. All other qualified events are ignored while the timer is timing. The first qualified event to occur after the timer has finished will trigger a sweep.

Hold Off Triggering can be executed either by the front panel controls or by the remote control commands.

Front Panel Operation

Front panel operation provides Interval Triggering.

Remote Control Operation

Remote control operation provides Interval or Pulse Width triggering.

See your Nicolet Remote Command Set manual (p/n 269-9094xx) for more information.

The Triggering Signal

Input the triggering signal to the External input BNC or to one of the installed channel's input BNCs. Use the trigger Source button to match your selection.

Note: 'OR' triggering is not allowed with Hold Off triggering. In addition, the Glitch, Dropout, Hold Off, n Event and Adv Triggering are mutually exclusive. Only one can be enabled at a time.

Making Time Measurements

All time measurements are made with respect to the trigger time (t=0) origin.

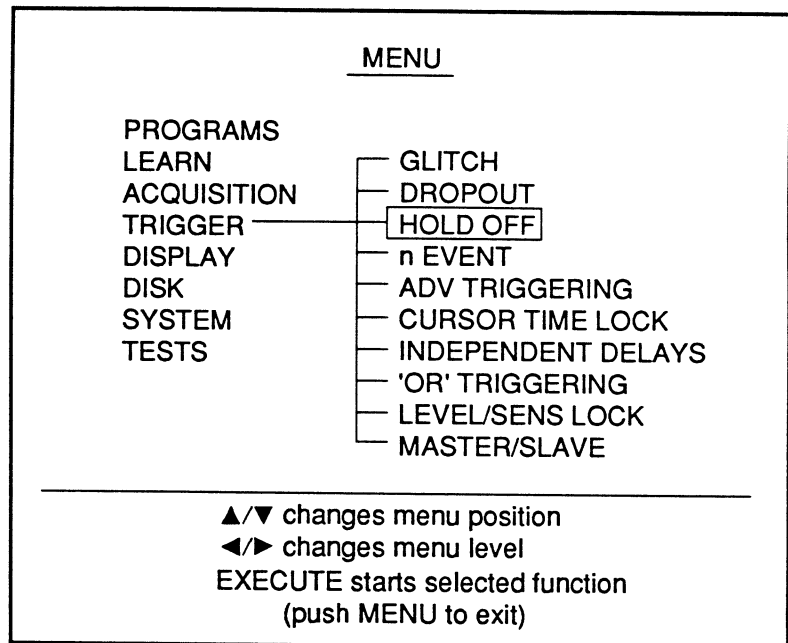

Figure 1 - Hold Off triggering selected

Example

Figures 1 and 2 illustrate signals which start user-defined timers. The first qualifying event to occur after the timer has timed out will trigger a sweep.

Note: Positive Slope triggering is used for both examples.

Figure 1: Hold Off-Interval

With **positive slope triggering** selected, the timer is started by a qualifying positive slope event. After the timer times out, the next qualifying positive slope event triggers the sweep.

With **negative slope triggering**, only negative slope events can start the timer and trigger a sweep after the timer times out.

Figure 2: Hold Off-Pulse

With **positive slope triggering** selected, the timer is started by a qualifying negative slope event. After the timer times out, the next qualifying positive slope event triggers the sweep.

With **negative slope triggering**, positive slope events start the timer and negative slope events trigger sweeps.

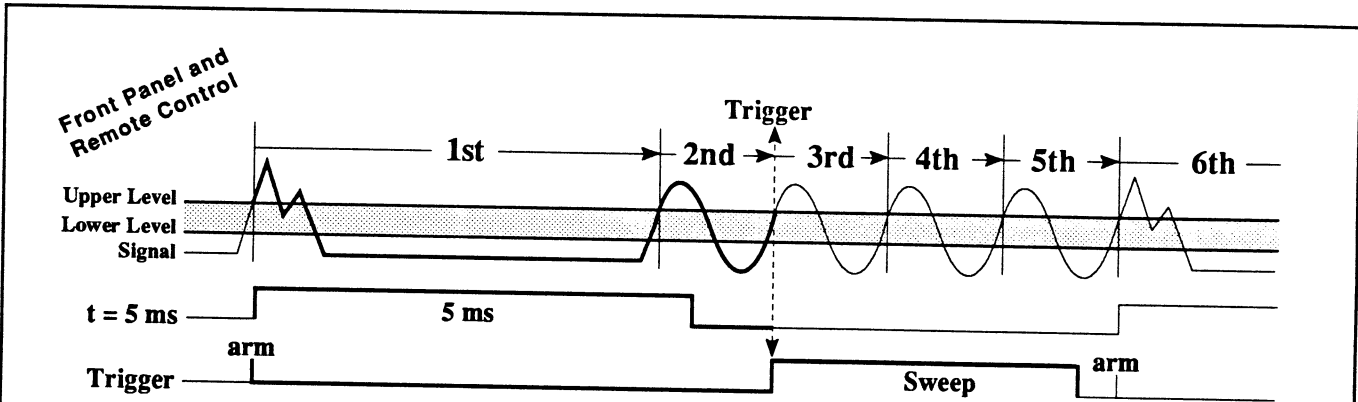

Figure 1 - Hold Off-Interval - The timer is set to 5 ms. The **positive slope event** in the 1st cycle starts the timer, thus holding off the positive slope event at the start of the 2nd cycle from triggering a sweep. The timer finishes timing out during the 2nd cycle which now allows the **positive slope** in the 3rd cycle to trigger a sweep. This example illustrates positive slope triggering.

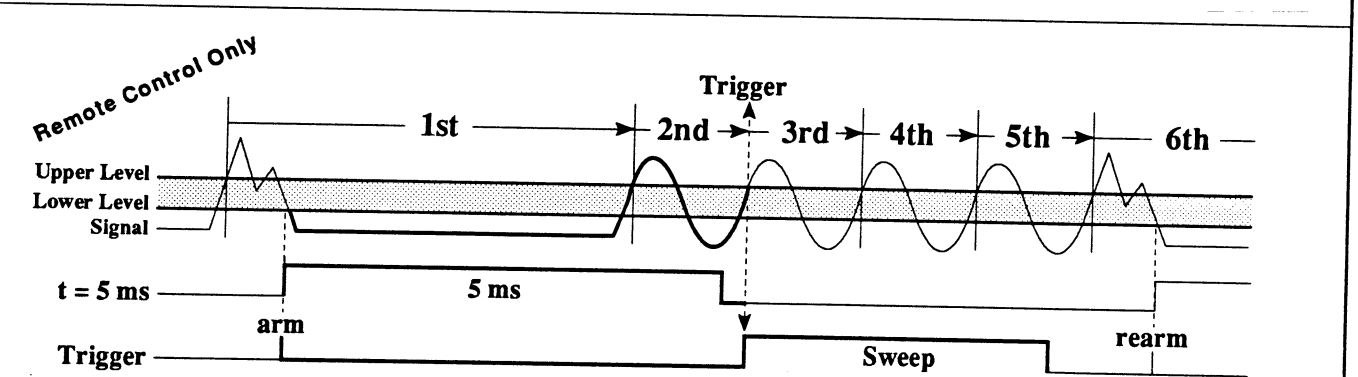

Figure 2 - Hold Off-Pulse Width - The timer is set to 5 ms. The **negative slope event** in the 1st cycle starts the timer, thus holding off the positive slope event at the start of the 2nd cycle from triggering a sweep. The timer finishes timing out during the 2nd cycle which now allows the **positive slope** at the start of the 3rd cycle to trigger a sweep. This example illustrates positive slope triggering.

Setting the Hold Off Function

1. Press the Menu button. The Menu display appears.
2. Using the cursor buttons, select the Trigger menu and then press the Execute button.
3. Using the cursor buttons, select 'Hold Off' and then press the Execute button.
4. Press the trigger Source button until the desired source appears.
5. Press the trigger Slope button until the desired slope appears.
6. Press the "Level/Sens, Time/Count" button until the Time/Count LED lights.
7. Adjust the trigger Time/Count control knob until the desired value "n" appears on the screen.
8. When ready, press Execute to return to the waveform display.

Note: To disable Hold Off triggering, select 'Hold Off' on the Trigger Menu display and press the Execute button to remove the check mark. Hold Off triggering is disabled automatically if you enable Glitch, Dropout, n Event or Adv Triggering.

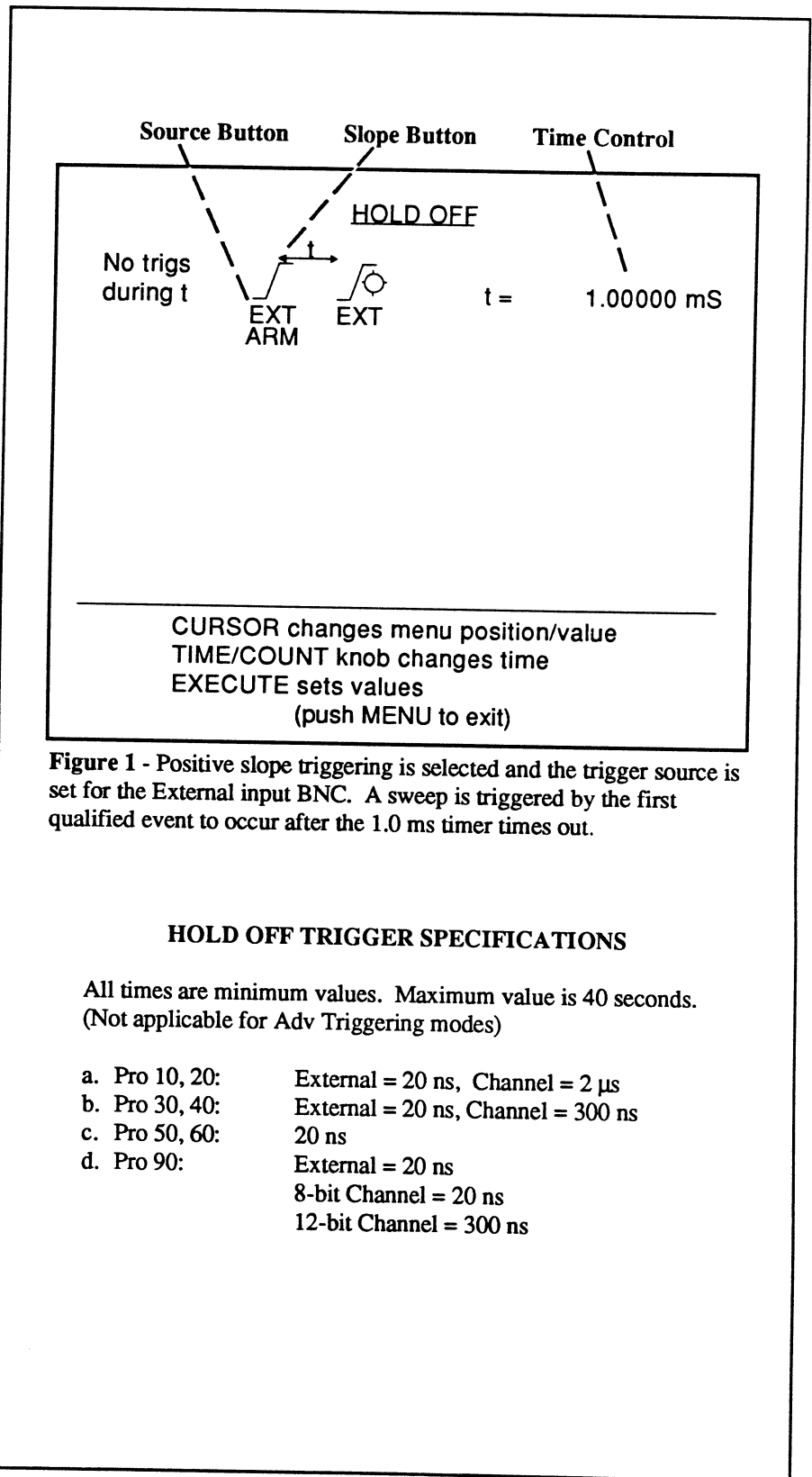

Figure 1 - Positive slope triggering is selected and the trigger source is set for the External input BNC. A sweep is triggered by the first qualified event to occur after the 1.0 ms timer times out.

HOLD OFF TRIGGER SPECIFICATIONS

All times are minimum values. Maximum value is 40 seconds.
(Not applicable for Adv Triggering modes)

- | | |
|----------------|---------------------------------------|
| a. Pro 10, 20: | External = 20 ns, Channel = 2 μ s |
| b. Pro 30, 40: | External = 20 ns, Channel = 300 ns |
| c. Pro 50, 60: | 20 ns |
| d. Pro 90: | External = 20 ns |
| | 8-bit Channel = 20 ns |
| | 12-bit Channel = 300 ns |

n EVENT TRIGGERING

n Event Triggering employs a user-defined counter to count qualified events. A sweep is triggered when the desired number of events have been counted. The minimum counter value allowed is two (2).

Dropout Triggering can be executed either by the front panel controls or by the remote control commands.

Front Panel Operation

Front panel operation provides Interval Triggering.

Remote Control Operation

Remote control operation provides Interval or Pulse Width triggering.

See your Nicolet Remote Command Set manual (p/n 269-9094xx) for more information.

The Triggering Signal

Input the triggering signal to the External input BNC or to one of the installed channel's input BNCs. Use the trigger Source button to match your selection.

Note: 'OR' triggering is not allowed with n Event triggering. In addition, the Glitch, Dropout, Hold Off, n Event and Adv Triggering are mutually exclusive. Only one can be enabled at a time.

Making Time Measurements

All time measurements are made with respect to the trigger time (t=0) origin.

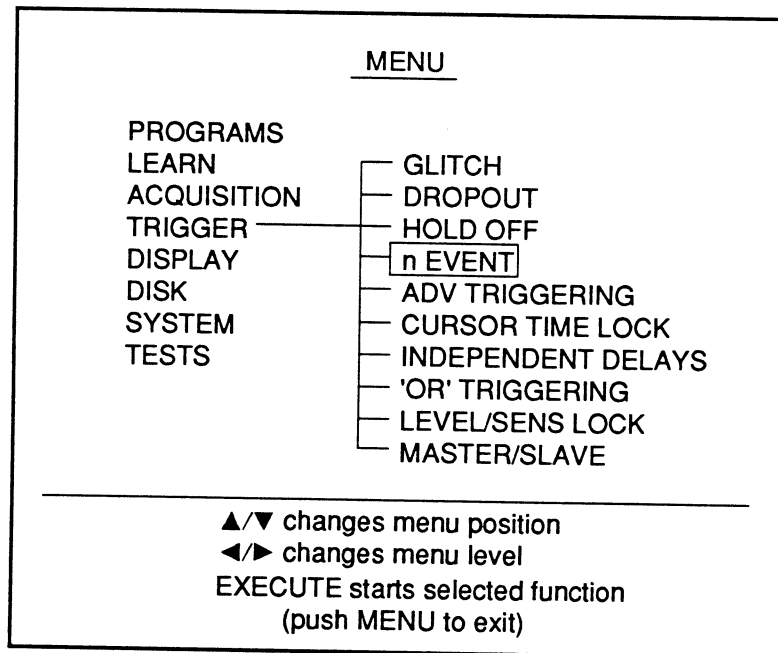

Figure 1 - n Event triggering selected

Examples

Figures 1 and 2 illustrate signals which armed user-defined counters. A sweep is triggered when the number of qualifying events equals the counter setting.

Note: Positive Slope triggering is used for both examples.

Figure 1: n Event-Interval

With **positive slope triggering** selected, the counter only counts qualifying positive slope events. A sweep is triggered when the fourth event is counted because the counter is set to four ($n = 4$).

With **negative slope triggering**, only negative slope events are counted.

Figure 2: n Event-Pulse

With **positive slope triggering** selected, the counter counts the first qualifying negative slope event and then each qualifying positive slope event thereafter. A sweep is triggered when the fourth event is counted because the counter is set to ($n = 4$).

With **negative slope triggering**, the first qualifying positive slope is counted and then each qualifying negative slope thereafter.

Front Panel and Remote Control

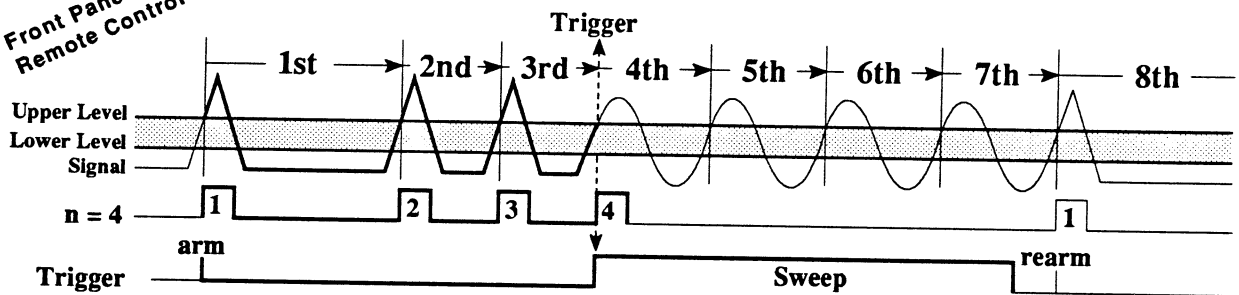

Figure 1 - n Event-Interval - The counter is set to four ($n = 4$). The counter counts only qualified positive slope events and triggers the sweep when it reaches a count of four (4). This example illustrates positive slope triggering.

Remote Control Only

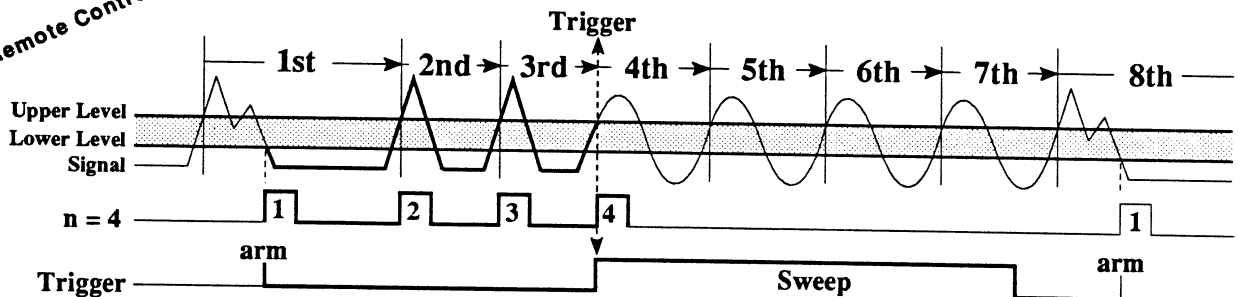
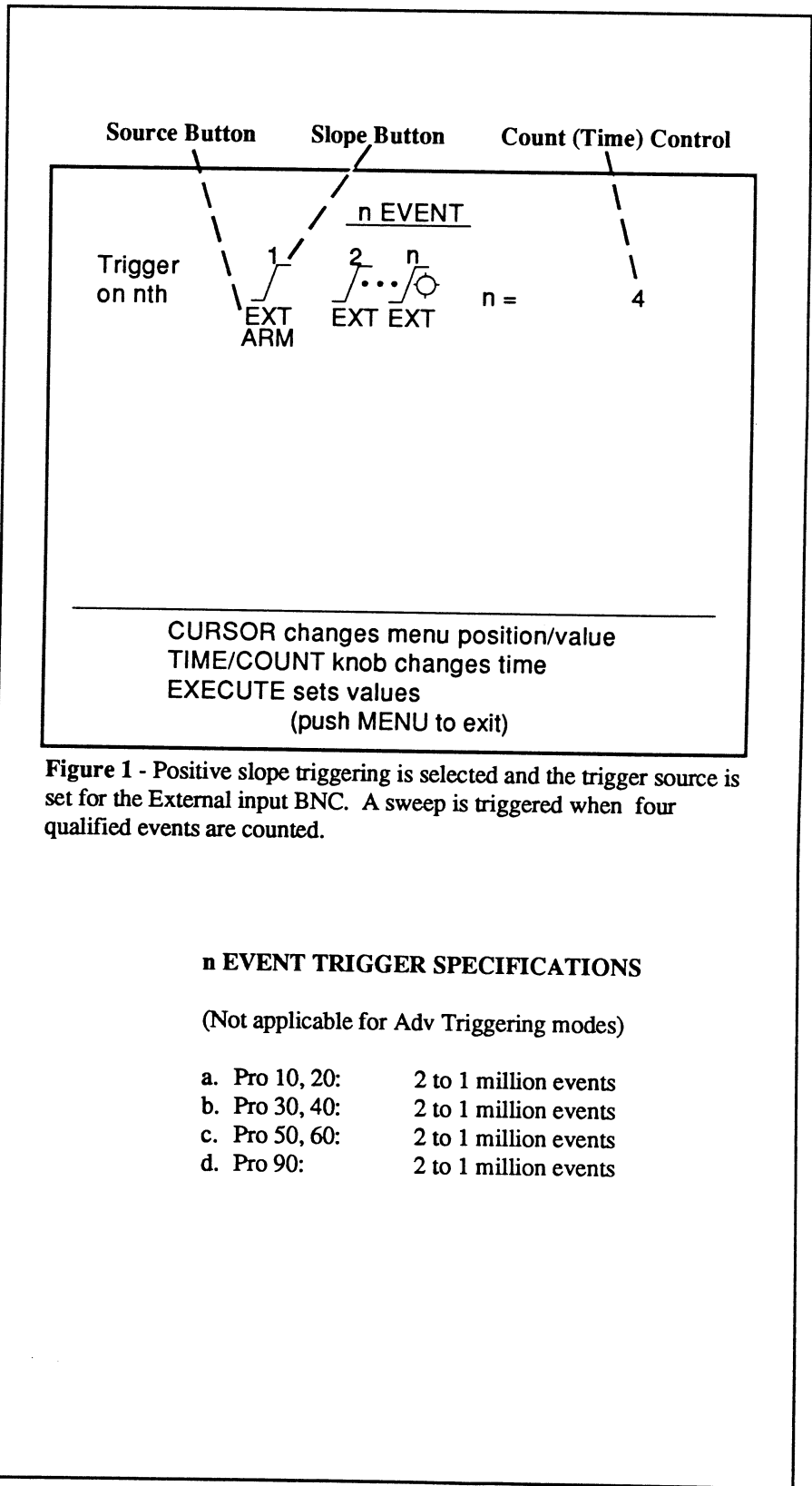

Figure 2 - n Event-Pulse Width - The counter is set to four ($n = 4$). The counter counts the first qualified negative slope event and then only qualified positive slope events thereafter. A sweep is triggered when the counter reaches a count of four (4). This example illustrates positive slope triggering.

Setting the n Event Function

1. Press the Menu button. The Menu display appears.
2. Using the cursor buttons, select the Trigger menu and then press the Execute button.
3. Using the cursor buttons, select 'n Event' and then press the Execute button.
4. Press the trigger Source button until the desired source appears.
5. Press the trigger Slope button until the desired slope appears.
6. Press the "Level/Sens, Time/Count" button until the Time/Count LED lights.
7. Adjust the trigger Time/Count control knob until the desired value "n" appears on the screen.
8. When ready, press Execute to return to the waveform display.

Note: To disable n Event triggering, select 'n Event' on the Trigger Menu display and press the Execute button to remove the check mark. n Event triggering is disabled automatically if you enable Glitch, Dropout, Hold Off or Adv Triggering.



ADV TRIGGERING

Advanced Triggering provides additional features which enhance the basic Glitch, Dropout, Hold Off and n Event functions. See the preceding discussions on Glitch, Dropout, Hold Off and n Event earlier in this chapter for the basic descriptions of these functions.

This section describes the additional features available for your use when using Advanced Triggering. Also see *Chapter 13*, Status button.

Note: 'OR' triggering is not allowed with any of the Adv triggering functions. Also, the Glitch, Dropout, Hold Off, n Event and Adv Triggering are mutually exclusive. Only one can be enabled at a time.

Additional Features

- You can derive the "arm" events and "trigger" events from different trigger sources.
- You can select (except for the External input BNC) individual trigger Level/Sensitivity values on the Pro 10, 20, 30, and 40. For example,
Ch1 ARM Level = 10 mV and
Ch1 TRIG Level = 40 mv.
- You can mix or match trigger slopes for the "arm" and "trigger" events.
- You can select Dual Slope triggering except for the external trigger source.
- When using Dropout triggering, you can select to re-arm the instrument if a valid trigger attempts to initiate a sweep before the timer "t" times out.

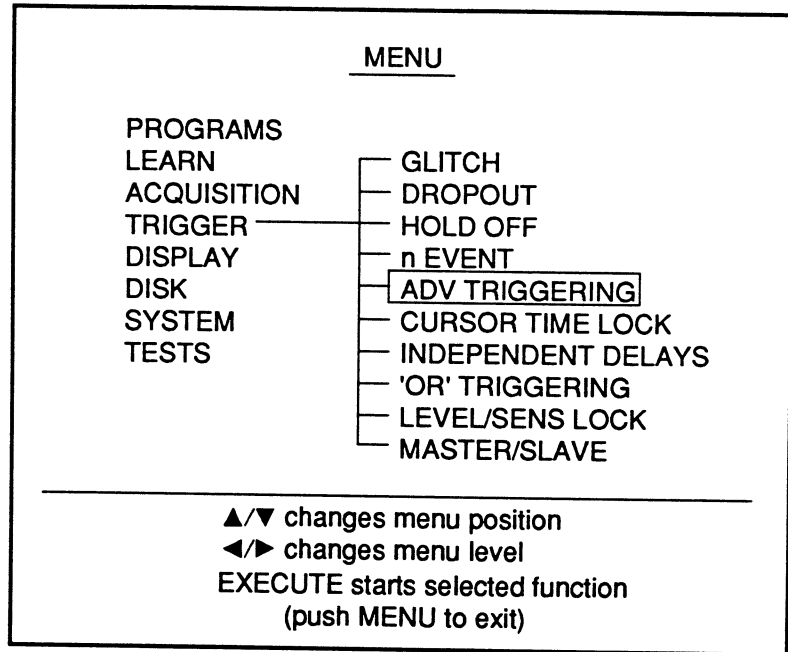

Figure 1 - Advanced Triggering selected

The Advanced Trigger Menus

Figures 1 through 4 show the four triggering functions accessed via the Adv Trigger menu.

The main difference between the Advanced Trigger functions and those discussed earlier in this chapter is the ability to mix or match trigger sources and trigger slopes for the Arm and Trigger event signals.

Drop Out Triggering Selected

Note in Figure 2 the additional field "RE-ARM REQUIRED IF TRIGGER OCCURS DURING t?." Also see the example on page 18-18.

Enter YES to restart the timer only if another valid arm event is received.

Enter NO to restart the timer if a valid trigger event occurs before the timer times out.

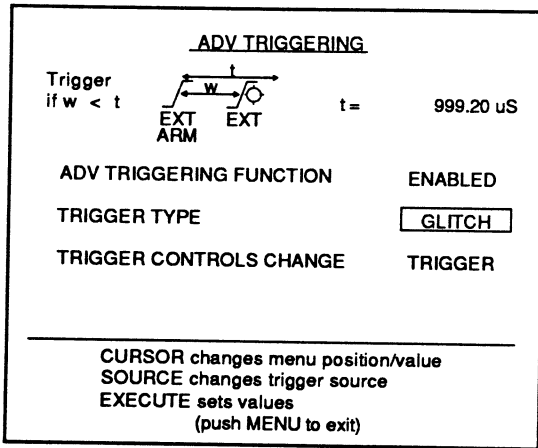

Figure 1 - Glitch triggering is selected.

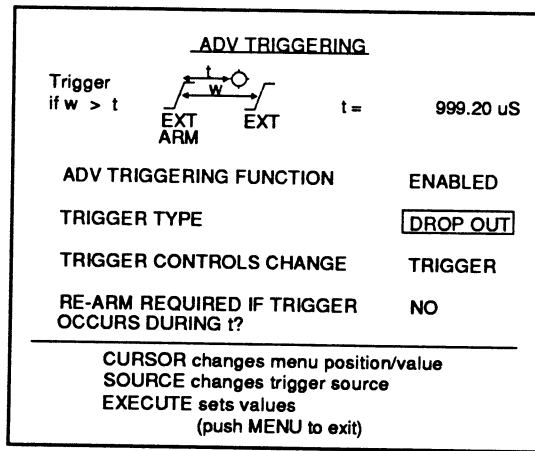

Figure 2 - Drop Out triggering is selected. Note that you can select to restart the timer. See the 'Drop out triggering selected' description above.

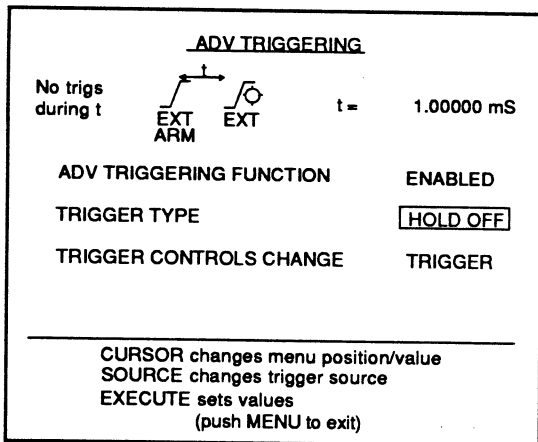

Figure 3 - Hold Off triggering is selected.

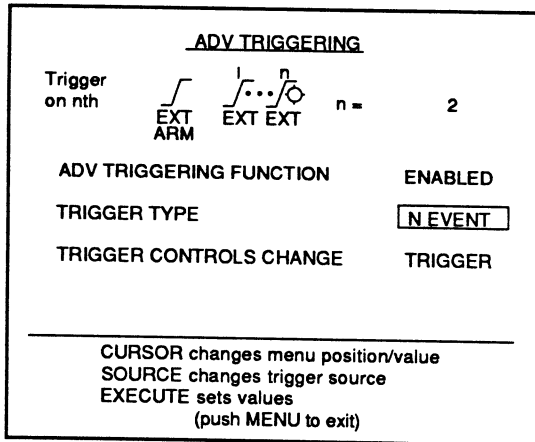

Figure 4 - n Event triggering is selected.

Setting Arm/Trigger Slopes

You can mix or match Arm and Trigger slopes. For example, Arm can be set for positive slopes and Trigger for negative slopes (Figure 1).

Note: External Dual Slope triggering is not allowed.

To change the Arm slope, display ARM in the "Trigger Controls Change" field (Figure 1). To change the Trigger slope, select TRIGGER (Figure 2).

Slope changes made to one function also changes the other three functions. For example, changing the Hold Off function's Arm slope from positive to negative also changes the other three functions' Arm slope to negative.

You can also change the trigger Slope from the waveform display. Press the trigger Source button to select ARM or TRIG in the lower left corner of the waveform display screen (Figure 3) and then the desired slope.

Setting Arm/Trigger Sources

You can derive Arm and Triggering signals from different sources. For example, you can derive the Arm signal from Channel 1 and the Trigger signal from Channel 2 (Figure 1).

Note: You must use the Adv. Triggering function screen to change the Arm and Trigger sources. The trigger source cannot be changed while viewing the waveform display screen.

Source changes made to one function also changes the other three functions. For example, changing the Hold Off function's Arm source from Channel 1 to EXT also changes the Arm source to EXT for the other three functions.

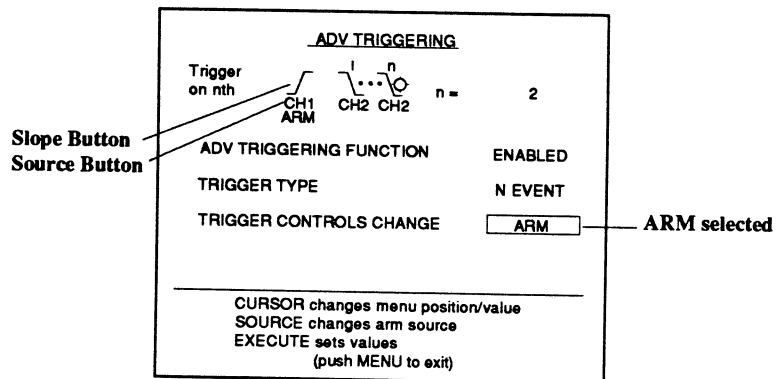

Figure 1 - The positive slope ARM signal will be derived from channel 1 and the negative slope TRIGGER signal from channel 2. With ARM selected, the trigger Slope and Source buttons control the Arm signal's slope and source settings.

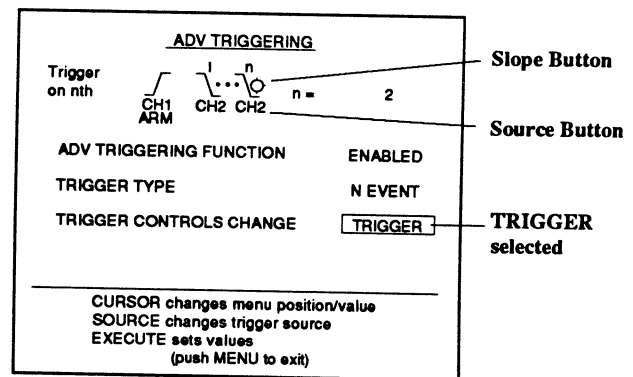

Figure 2 - With TRIGGER selected, the trigger Slope and Source buttons control the Trigger signal's slope and source settings.

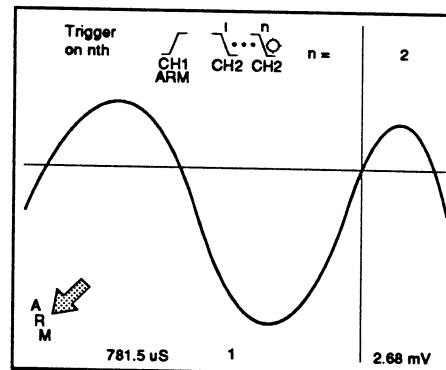

Figure 3 - Pressing the trigger SOURCE button will toggle between ARM (lower left corner of screen) and TRIGGER. This shows which signal will be controlled by the front panel trigger controls.

Advanced Triggering Thresholds

Pro 50, 60 and 90 Models

A Pro series configured with an 8 bit digitizer has its Arm and Trigger Level/Sens thresholds tied together. That is, changes made to the Arm level also affects the Trigger level.

Pro 10, 20, 30, and 40 Models

A Pro series without an 8 bit channel has independent Arm and Trigger Level/Sens.

Note: The exception is that the External input BNC has its Arm and Trigger Level/Sens thresholds tied together. Also, External Dual Slope triggering is not allowed.

Arming the Adv. Trigger Dropout Function

An additional feature in the Dropout triggering menu allows you to select whether the Pro will measure Trigger-to-Trigger (Figure 1) or Arm-to-Trigger (Figure 2) times.

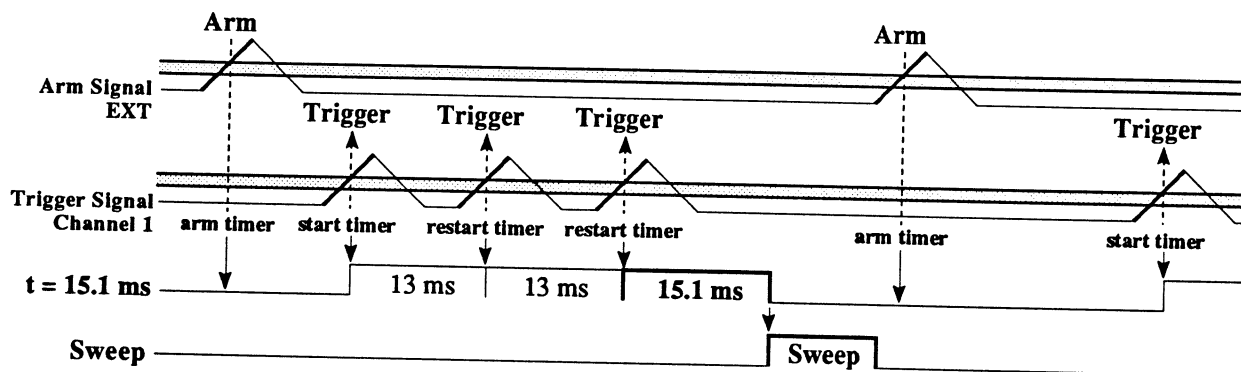

Figure 1 - ADV Triggering - Drop Out Answering with a NO for the "Re-arm required if trigger occurs during t?" parameter, the instrument measures the Trigger-to-Trigger time. If a Trigger occurs while the timer is timing, the timer is restarted at $t=0$. If the timer times out, a sweep is triggered and then a valid Arm signal is required at the end of the sweep to re-arm the timer. Once armed, a valid Trigger is required to start the timer.

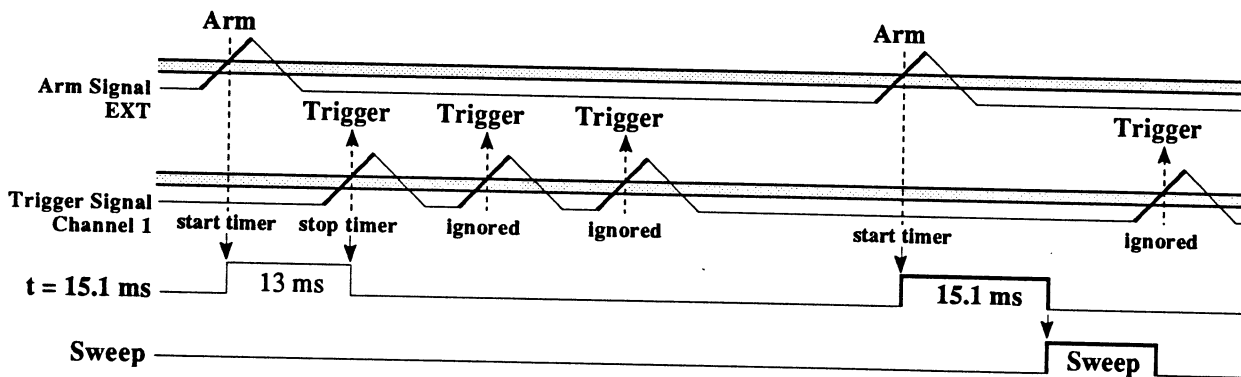

Figure 2 - ADV Triggering - Drop Out Answering with a YES for the "Re-arm required if trigger occurs during t?" parameter, the instrument measures Arm-to-Trigger time. If a valid Trigger occurs while the timer is timing, the timer stops and another valid Arm signal is required to start the timer again at $t=0$. If the timer times out, a sweep is triggered. The timer is re-armed by the next valid Arm signal after the sweep ends and then the next valid Trigger signal starts the timer.

CURSOR TIME LOCK

Cursor Time Lock allows the instrument to maintain a constant time interval between the trigger point and the position of the vertical cursor on the display screen when the Time setting is changed while capturing data in the Live mode.

This method of capturing specific areas of interest increases the time resolution of the displayed waveform because all of the data points are used to record the signal, rather than just a fraction of the total sweep length.

1. While in the Live mode, capture the signal and move the vertical cursor over the area of interest.
2. Execute Cursor Time Lock. A check mark appears next to Cursor Time Lock, indicating that it is now turned on.
3. Press the Menu button. The waveform display reappears and a small padlock symbol appears at the top of the screen. The padlock symbol reminds you that Cursor Time Lock is turned on.
4. Reduce the Time setting. The area of interest, in effect, expands horizontally to either side of the vertical cursor.

Note: If desired, the Horiz Trigger Position button can be pressed to move the area of interest horizontally on the screen. This will, however, alter the trigger point which in turn will affect the time numerics.

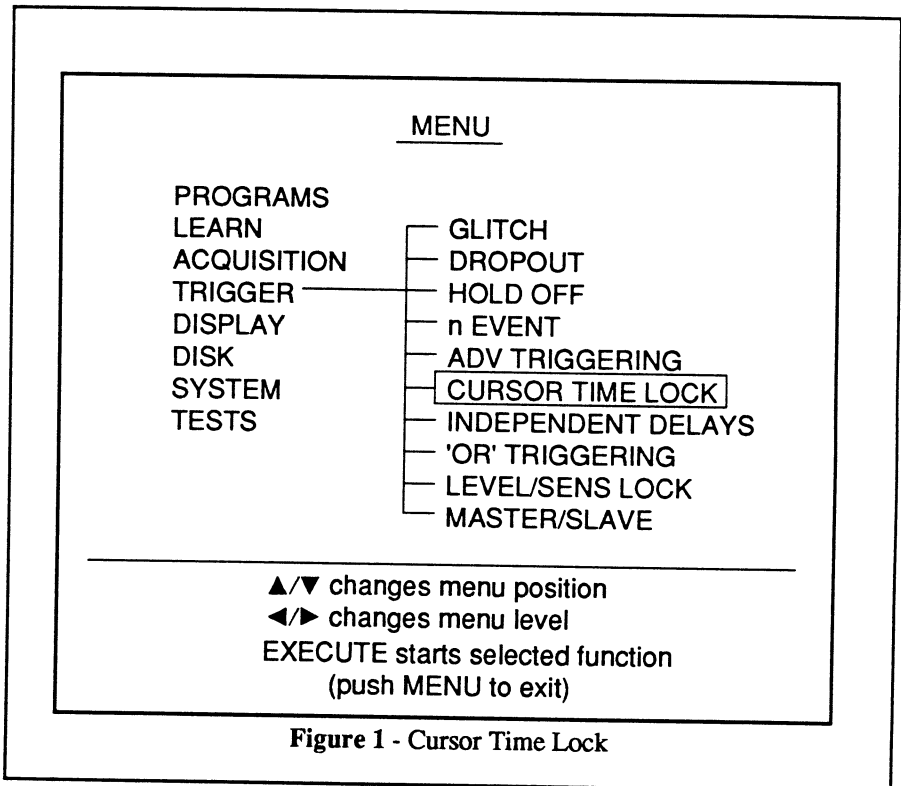

Figure 1 - Cursor Time Lock

Example 1

Figure 2a - The Sweep Length function was set for 30k data points. The second peak of the signal contains an area of interest which is displayed on the screen using 15k of the total sweep length of 30k data points.

Figure 2b - The vertical cursor was moved over the area of interest and the Cursor Time Lock function was turned on. This resulted in an enlarged view of the area of interest using all 30k data points, thus doubling the time resolution.

To further illustrate this feature, see the examples on the next page comparing the effects of reducing the Time setting with Cursor Time Lock turned off and then again with it turned on.

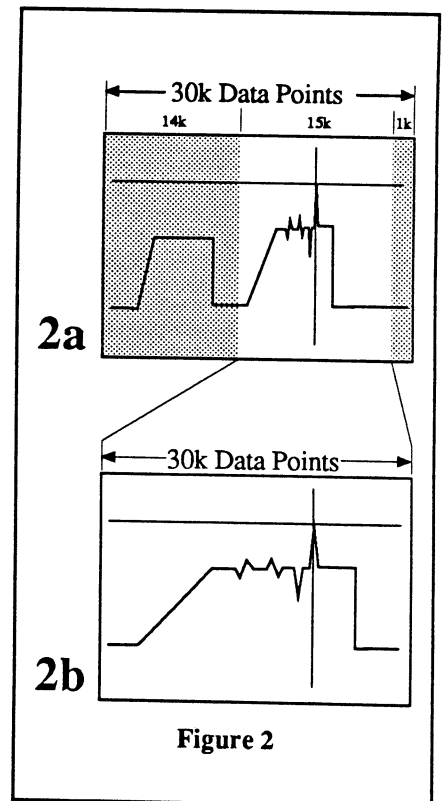

Figure 2

Example 2 - Cursor Time Lock OFF

Figure 1 - The signal was captured with a 10 μ S Time setting and the signal has an interesting area of data towards the end of the sweep. Note that the Time numerics shows that the vertical cursor is at 6.46 mS.

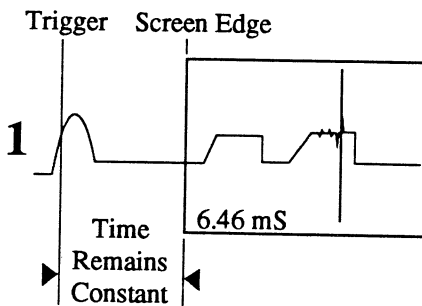

Figure 2 - To obtain a more enhanced time resolution of the area of interest, the Time setting was decreased to 5 μ S. Note that the right edge of the screen, in effect, has been compressed towards the trigger.

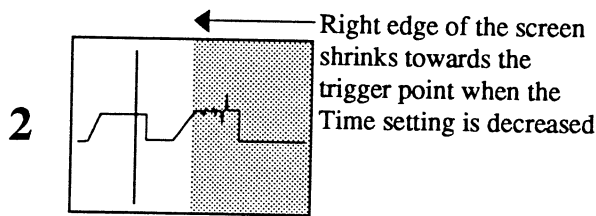
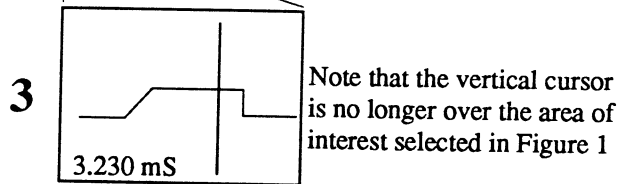

Figure 3 - The resulting display is now missing the area of interest because it was forced off the screen. Note that the Time numerics is now decoding the position of the vertical cursor as 3.230 mS.



Example 3 - Cursor Time Lock ON

Figure 4 - The signal was once again captured with a 10 μ S Time setting and Cursor Time Lock was turned on. Now the time between the trigger point and the position of the vertical cursor will remain constant as the Time setting is decreased.

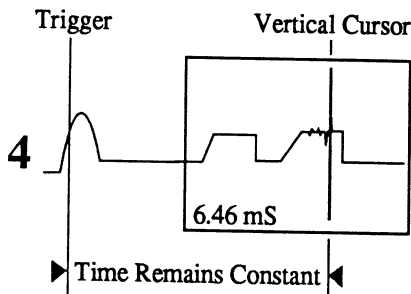

Figure 5 - The Time setting was decreased to 5 μ S. This, in effect, causes the left and right edges of the screen to compress towards the vertical cursor.

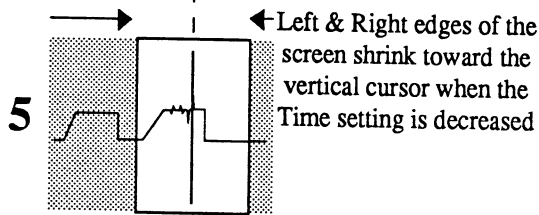
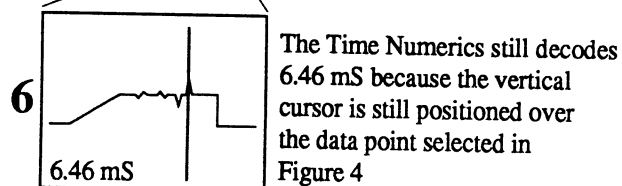

Figure 6 - The resulting display now shows the area of interest with a higher time resolution. Note that the time coordinate of the vertical cursor is still at 6.46 mS.



'OR' TRIGGERING

'OR' Triggering allows any signal input to the front panel input BNC(s) to trigger a sweep when it qualifies as a valid trigger. The input BNC(s) must be ungrounded. A check mark will be displayed next to each of the inputs that are currently 'ORed' on the 'OR' Triggering selection screen (Figure 2).

This function is of particular importance when a one-shot trigger is anticipated and the trigger source is unknown.

1. Execute 'OR' TRIGGERING. The 'OR' Triggering selection screen appears (Figure 2).
2. Use the Up/Down Cursor buttons to move the selection box vertically and the Left or Right Cursor buttons to select/deselect the front panel input BNC's as desired.

A check mark indicates that the front panel input BNC designation has been activated. A valid trigger input to any of the activated input BNCs will trigger a sweep on all channels that are turned on.

3. After making all of the selections, press the Execute button. The waveform display returns and the word 'OR' appears towards the top of the display screen.

Note: If you only select (check mark) a single input, the front panel Trigger Source will default to the corresponding selection. For example, if you only check mark CHANNEL 2, then the trigger Source will default to channel 2.

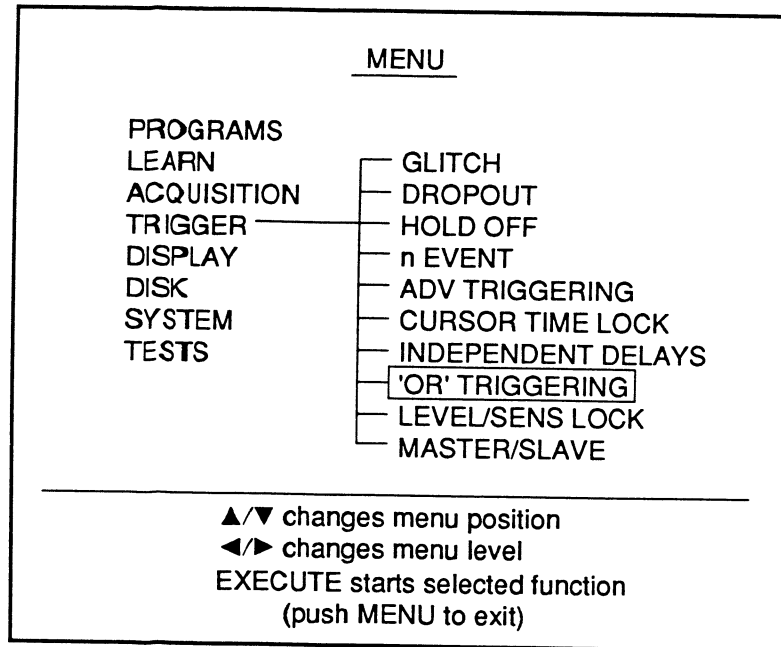

Figure 1 - 'OR' Triggering

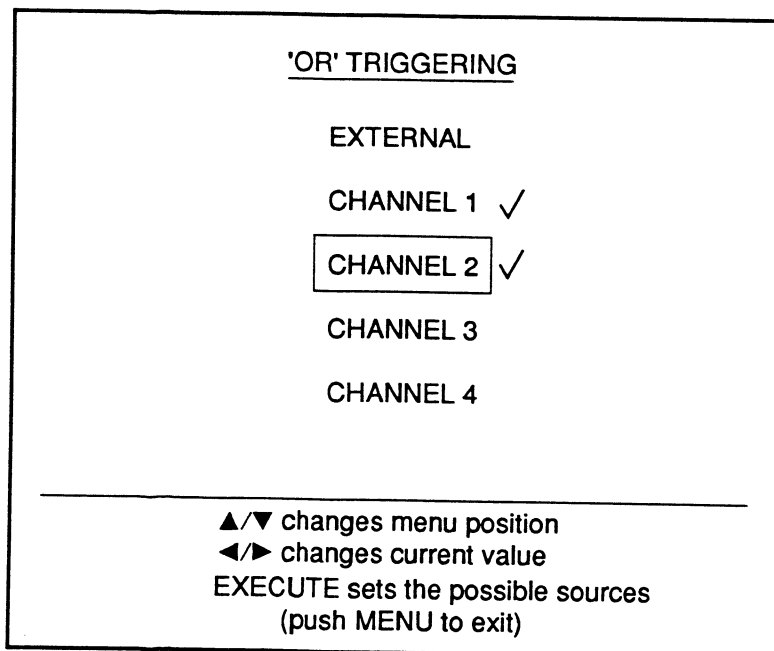

Figure 2 - 'OR' Triggering Selection Screen showing that CHANNEL 1 and CHANNEL 2 have been 'ORed'

LEVEL/SENS LOCK

Level/Sens Lock is used to maintain the trigger Level and Sensitivity settings proportional to any changes to the Volts setting as the volts full scale is increased or decreased.

1. Adjust the trigger Level and Sensitivity as desired for the signal being captured.
2. Execute LEVEL/SENS LOCK. A check mark appears to the right of the LEVEL/SENS LOCK field when the function is turned on.
3. Press the Menu button to return to the waveform display. Any changes made to the Volts setting will cause the trigger Level and Sensitivity to increase/decrease proportionally.

Execute LEVEL/SENS LOCK again to turn the function off. This causes the trigger Level and Sensitivity to remain unchanged while the Volts setting is changed.

Examples

The two examples at the right illustrate that effect of turning Level/Sens Lock on or off.

The first example shows the trigger Level and Sensitivity settings readjusted automatically as the Volts setting was increased to 30 volts, thus allowing the signal to still qualify as a valid trigger and initiate a new sweep.

The second example shows that the trigger Level and Sensitivity remained unchanged after increasing the Volts setting to 30V. The amplitude of the displayed waveform did not decrease because the signal no longer could qualify as a valid trigger, thus preventing a new sweep from being taken.

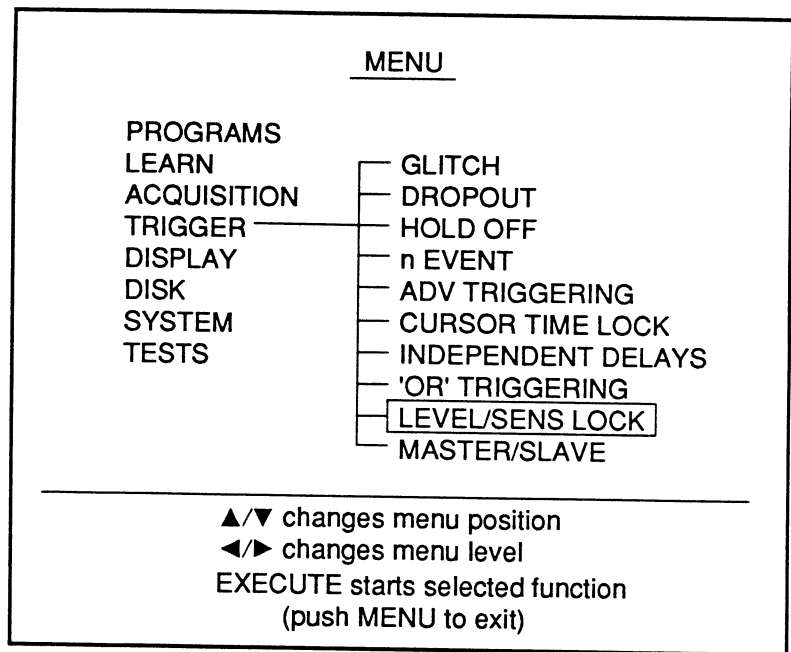
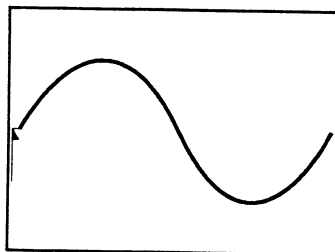
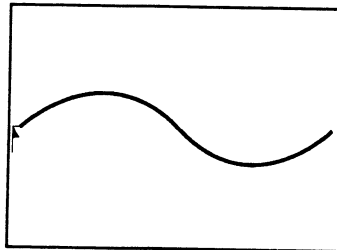

Figure 1 - Level/Sens Lock

Level/Sens Lock Turned ON



Volts set to 12V



Volts was increased to 30V. The Level/Sens readjusted automatically, thus allowing triggers to continue.

Level/Sens Lock Turned OFF

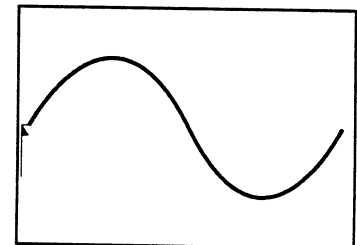

Volts set to 12V

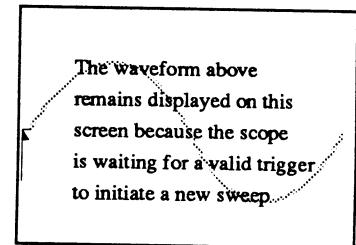

Volts was increased to 30V. The Level/Sens remained unchanged, thus the signal failed to trigger a new sweep.

MASTER/SLAVE

Master/Slave allows you to trigger several Systems from a single, valid trigger input to one of the instruments. For example, if three Systems are connected and the Master unit receives a valid trigger, a sweep will be triggered on all three units.

You can mix or match the front panel settings as desired for each individual Master/Slaved unit. For example, different Time or Volts settings.

A check mark at the end of MASTER/SLAVE in Figure 1 indicates that the instrument has been configured as either a Master unit or a Slave unit. If no check mark is present, the instrument is operating in the Normal mode.

Important: The order in which each unit is armed is very important. See the next page for information.

Setting Master/Slave

1. Execute MASTER/SLAVE. The Master/Slave Selection Screen appears (Figure 2).
2. Press the Cursor buttons until the desired mode appears in the selection box (OFF, MASTER, SLAVE). If the instrument you are setting up is to be the Master unit, select the word MASTER. If the instrument is to be a Slave unit, select the word SLAVE.
3. Press the Execute button.
4. Repeat the above procedure for each of the instruments that are to included in the Master/Slave configuration.
5. Interface the instruments, see the next page.

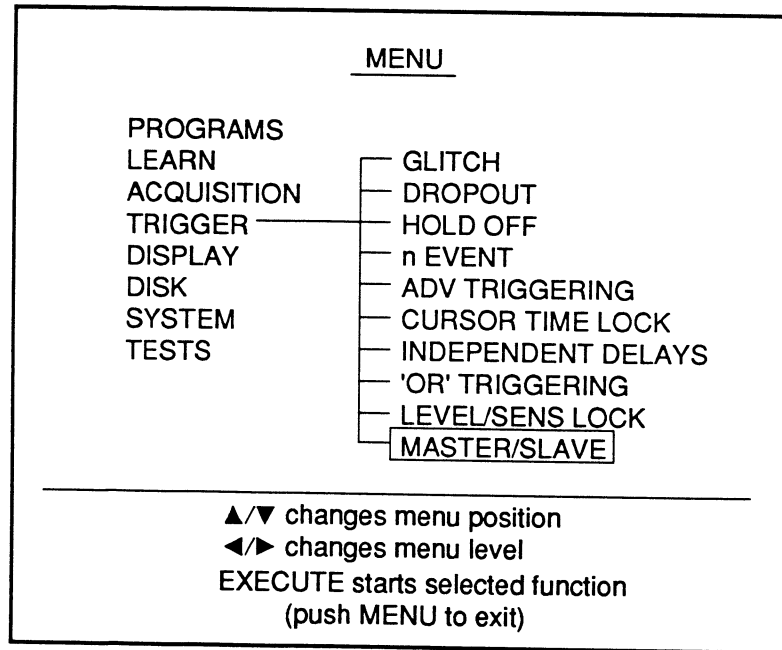

Figure 1 - Master/Slave

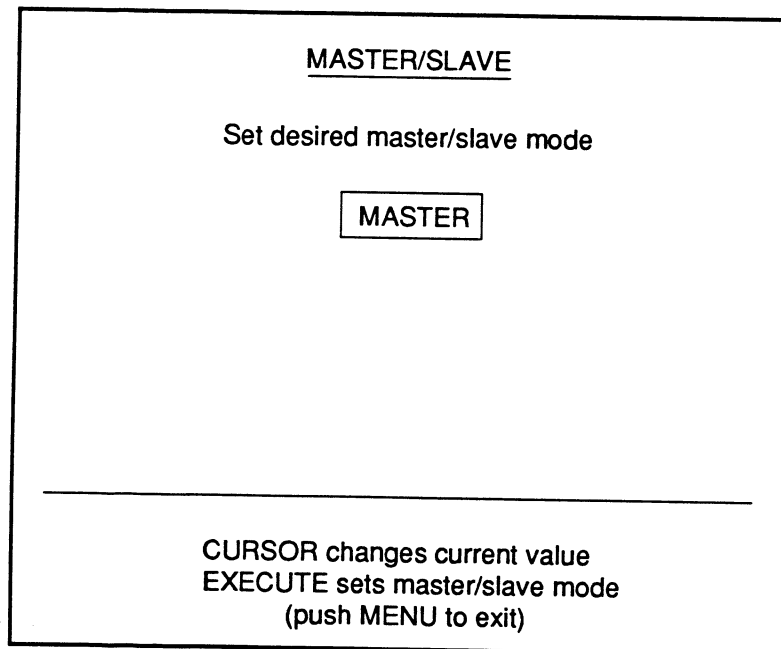

Figure 2 - Master/Slave Selection Screen

Continued on the next page

Connecting the Systems

1. Connect the Systems in series as shown in Figure 1.
2. Connect a BNC cable between the Master Trigger Out BNC and Slave #1 Trigger In BNC.
3. Connect a BNC cable between the Slave #1 Trigger Out BNC and the Slave #2 Trigger In BNC.
4. Continue connecting BNC cables between each additional Slave unit until all Slave units have been interfaced.
5. Connect a BNC cable between the last Slave unit's Trigger Out BNC and the Master units Trigger In BNC.

Arming the Systems

After setting and connecting of the Master/Slave units, use the front panel controls or the Remote Command Sets commands to arm each of the units. Begin with the last Slave unit in the string and then work, in reverse order, towards the Master unit. If this is not done, the sweeps may not be synchronized.

For example, begin with Slave #2 in Figure 1 and arm it in the Live, Hold Next, or Autocycle mode. Next, arm Slave #1 and then finish the arming sequence with the Master unit.

Master Unit Status Indicators

The Master unit will display "SYSTEM READY" in the upper left corner of its display screen when all of the Slave units have completed their sweeps. If "SYSTEM NOT READY" is displayed, it means -

- a. At least one of the Slave units is still sweeping or filling its buffer memory, and/or
- b. The Master unit is performing an internal function (e.g., filling its buffer memory) and is not ready to accept the next trigger.

Slave Unit(s) Status Indicators

Each Slave unit will display "SLAVE ARMED" after completing its sweep and ready to accept the next trigger from the Master unit. If "SLAVE NOT READY" is displayed, it means -

- a. The Slave unit has not finished its current sweep, or
- b. The Slave unit is filling its buffer memory.

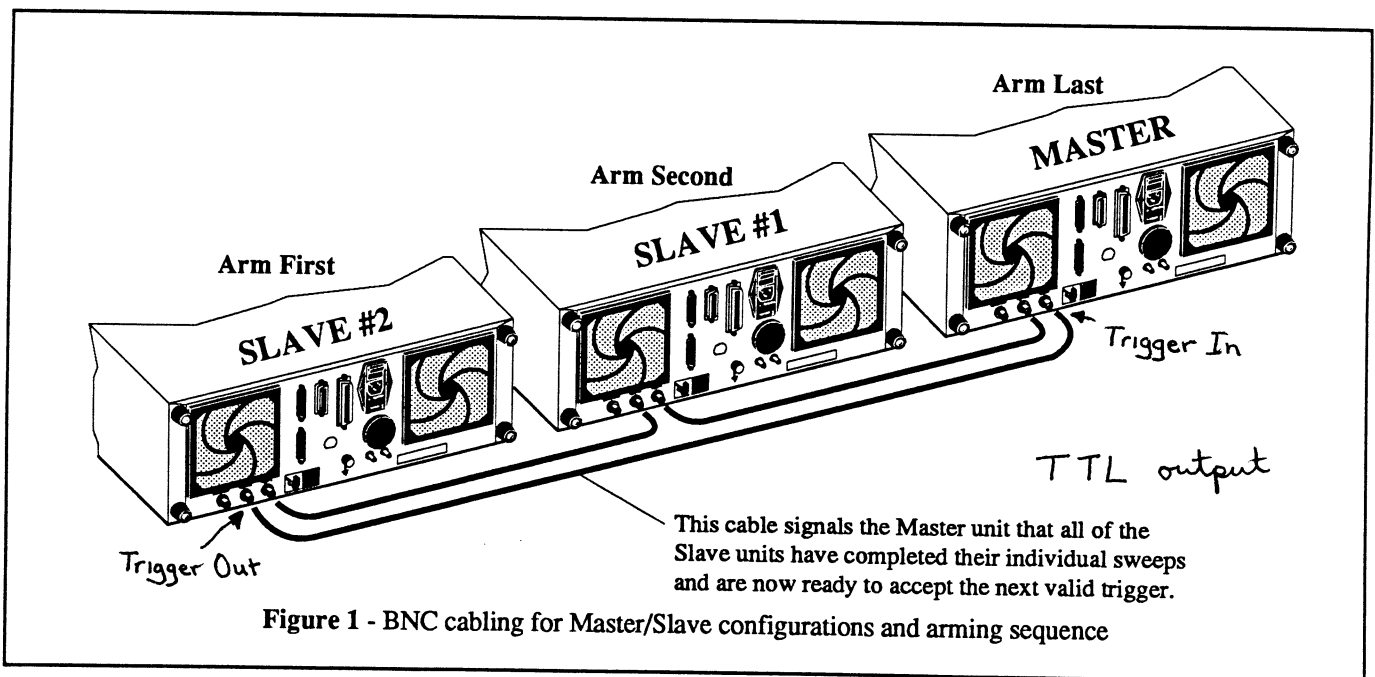

Pulse Duration

TRIGGERING SPECIFICATIONS

The values in Table 1 are for the Glitch, Dropout, Hold Off and n Event trigger modes; the Arm and Trigger sources must be the same. Table 1 is not applicable for the ADV TRIGGERING modes which allow you to mix or match Arm and Trigger sources.

	Model Pro 10 , 20	Model Pro 30 , 40	Model Pro 50 , 60	Model Pro 90
n Event Trigger hold-off by event	2 to 1 million events	2 to 1 million events	2 to 1 million events	2 to 1 million events
Hold Off Trigger hold-off by time from:	a. External: 20 ns b. Channel: 2 μ s	a. External: 20 ns b. Channel: 300 ns	20 ns	a. External: 20 ns b. 8 Bit Ch: 20 ns c. 12 Bit Ch: 300 ns
Glitch Triggers on opposite slopes of pulses narrower than:	a. External: 20 ns b. Channel: 3 μ s	a. External: 20 ns b. Channel: 300 ns	20 ns	a. External: 20 ns b. 8 Bit Ch: 20 ns c. 12 Bit Ch: 300 ns
Dropout (without Rearm) Triggers on similar slopes of signals wider than:	a. External: 60 ns b. Channel: 3 μ s	a. External: 60 ns b. Channel: 300 ns	60 ns	a. External: 60 ns b. 8 Bit Ch: 60 ns c. 12 Bit Ch: 300 ns

Table 1 - All times are minimum values. The maximum time value is 40 seconds.

Chapter 19

THE DISPLAY

MENU

Cursor/Grid Options	19-2
Dot-Join	19-3
User Units	19-4
Channel Title	19-6
Print Screen	19-7
Max/Min	19-8

The Display menu allows you to select various methods of displaying information on the screen. These include the grid mode, joining data points with line segments, titling individual waveforms, and customizing units for the numerics readouts. You can also output the screen display to a dot matrix printer for a hard copy record.

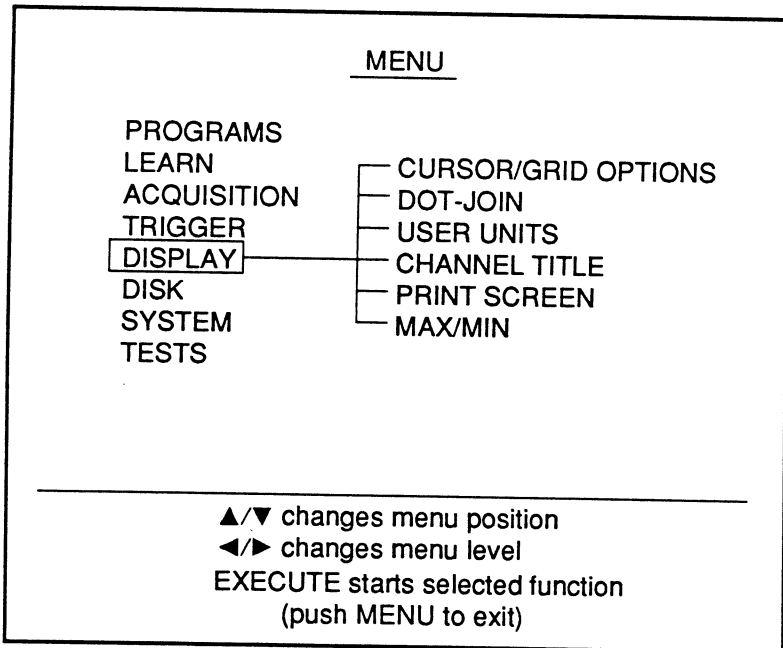

Figure 1 - The DISPLAY menu display

CURSOR/GRID OPTIONS

Cursor/Grid Options allows you to select whether data will be displayed along with the Vertical and Horizontal Cursors (the Cursor Mode) or with one of the electronic graticules modes (Grid Mode).

The Cursor Mode enables you to decode individual data points and read their values directly from the numerics using the horizontal and vertical cursors.

The Grid Mode is typically used for photographic records, allowing you to interpolate values according to the grid values.

1. Execute Cursor/Grid Options.
The waveform display returns with a selection prompt (Figure 2).
2. Press the Select button until the desired display appears and then press the Execute button.

The instrument can be operated in any of the grid modes the same way as in the cursor mode. (e.g., Capture live signals, display expansion, autocenter, $\Delta T/\Delta V$, etc.)

The upper numerics show the value per grid while the lower numerics continue to decode values selected by the cursor positions.

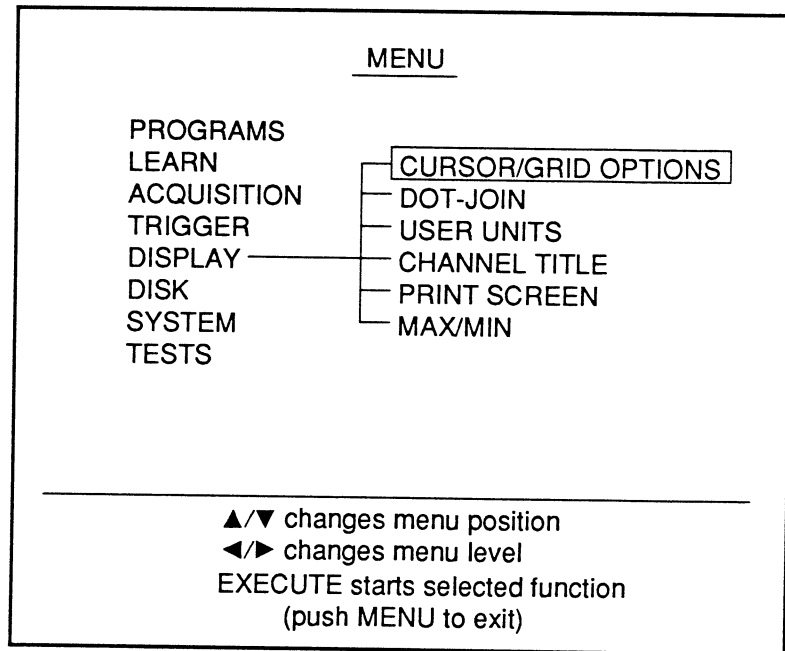

Figure 1 - Grid Options

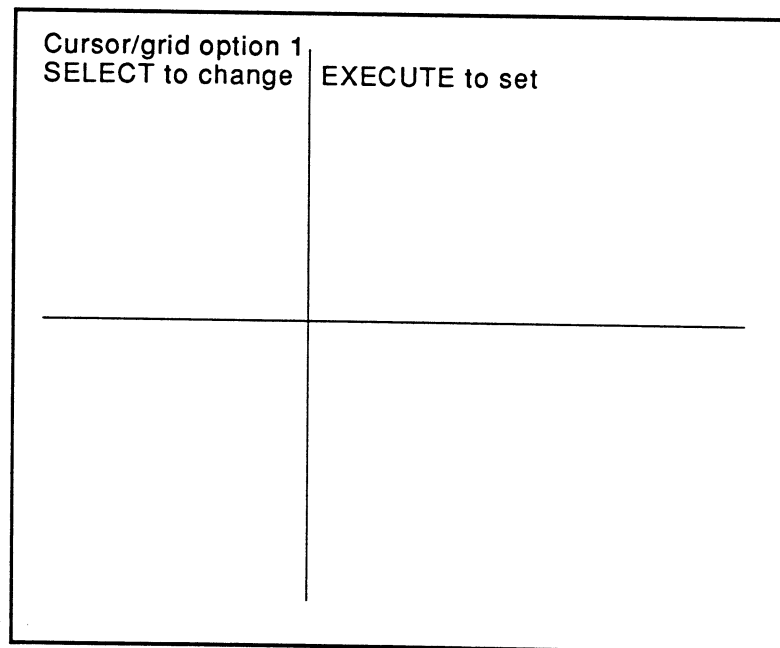



Figure 2 - Cursor/grid selection screen

DOT JOIN

Dot Join is used to join adjacent data points with line segments to help you view the expanded waveform or when a very short Sweep Length is being used to capture and display the signal.

1. Execute Dot-Join. A check mark will appear next to DOT-JOIN when Dot-Join is turned on.
2. Press the Menu button to return to the waveform display screen.
3. A Dot-Join marker  is displayed towards the top of the screen (Figure 2). When display expansion is turned on for closer inspections, adjacent data points will be connected with line segments as shown in Figure 2 to help you recognize the waveform shape.

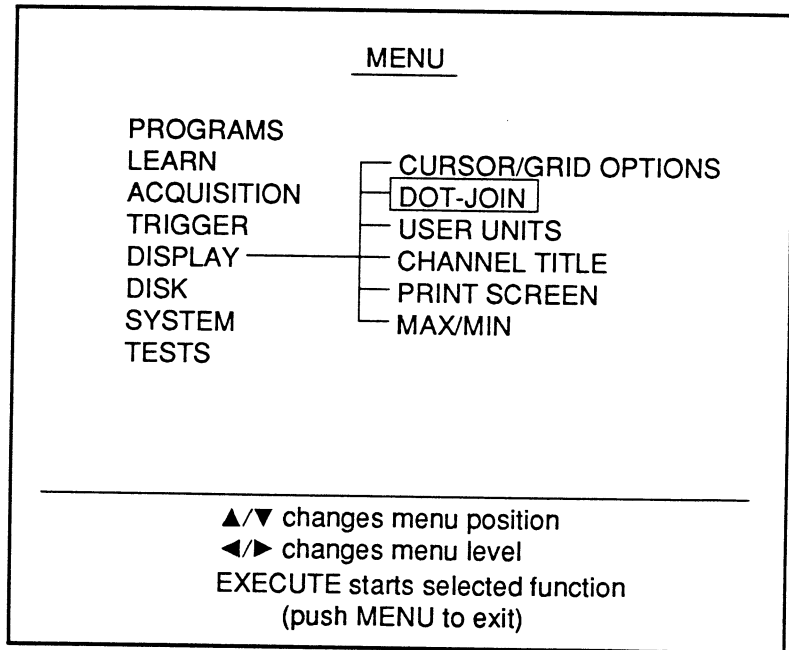

Figure 1 - Dot Join

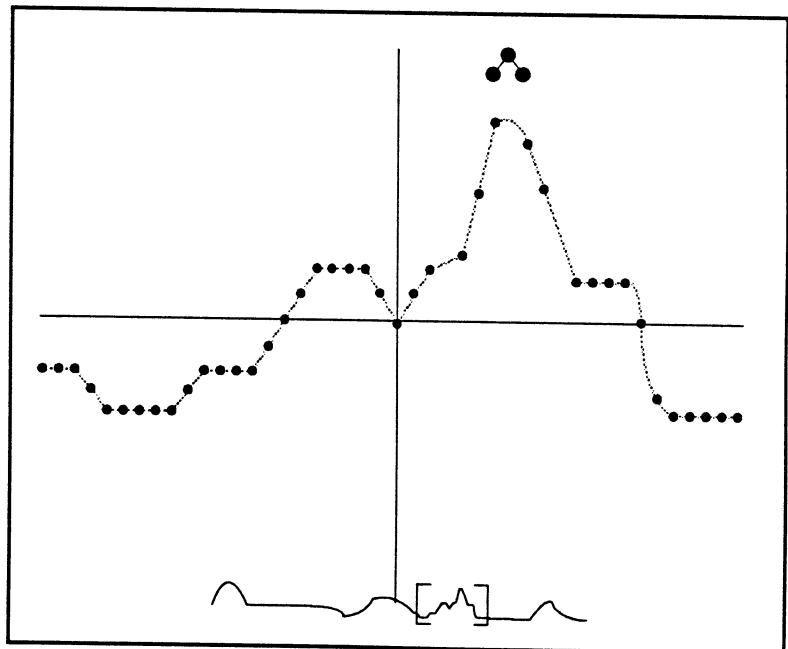

Figure 2 - Sample of Expanded Waveform with Dot Join Turned On

USER UNITS

User Units allows you to create customized units for the numerics. This can be done for the current waveforms in each of the channels and/or their Save Ref waveforms.

1. Execute USER UNITS. The User Units screen appears (Figure 2). The Select button allows you to view the current DEFAULTS, CH1, CH2, CH3 or CH4 settings. **DEFAULTS** allows you to quickly reset each channel to the defaults in Figure 2. **CH1, CH2, CH3 or CH4** shows you each of the channel's current settings.
2. Set the Scalar, Offset and Units fields as desired using the CURSOR buttons and TIME KNOB to make your selections. The Up/Down buttons alternates the pointer between the VERT and HORIZ fields. The Left/Right Cursor buttons move the pointer. The TIME knob selects the values/characters. Up to three characters can be entered in the Units field.
3. Press the channel On button to store the new units to that channel and/or press the channel's SAVE REF button to store the new units to the waveform stored in that channel's Save Ref memory allocation. For example, you can change the units for channel 2 by pressing channel 2's ON button, change the units again for channel 2's Save Ref waveform and then store those new units by pressing channel 2's SAVE REF button.
Note: Turning Save Ref off defaults it to the channel's units.
4. Press MENU to return to the waveform display. The new User Units will appear.

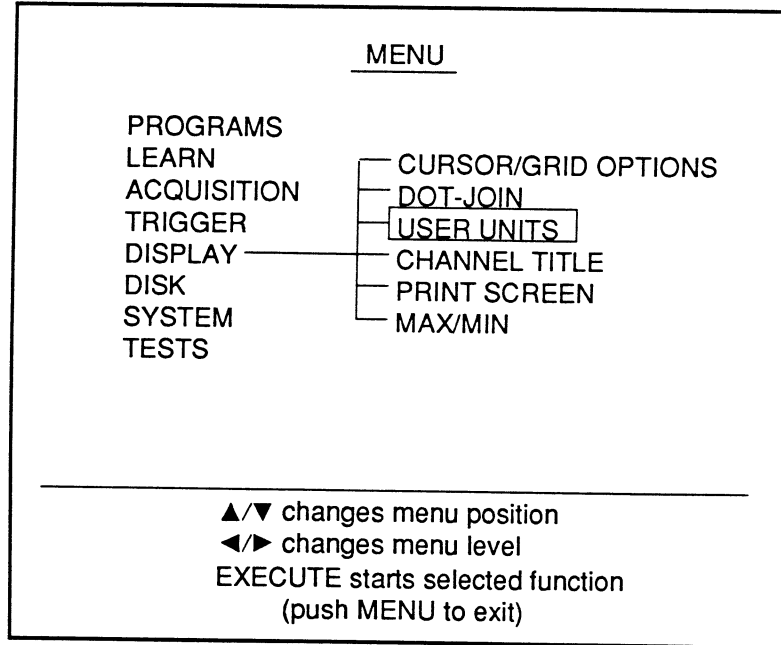

Figure 1 - User Units

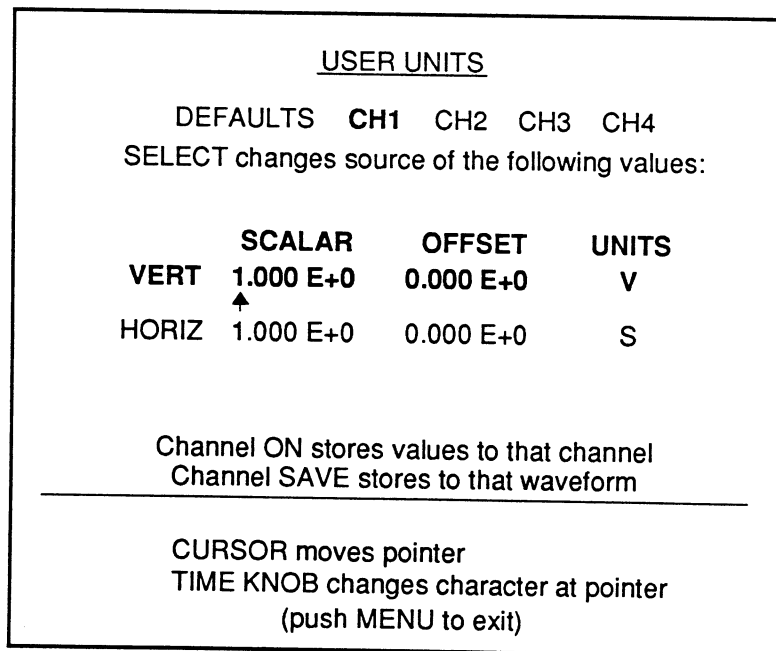

Figure 2 - User Units Settings Display

User Units Examples

Attenuating Probes and User Units

When using an attenuating probe (x10, x100, x1000) with your Pro system, use the User Units function to scale the display numerics for the proper amplitude read out.

1. Enter the probe's attenuation value (in scientific notation) in the Vertical Scaler field.

Example: For a x100 probe, enter 100 into the Vertical Scaler in this format: 1.000 E 2.

Transducers and User Units

When using a transducer, use the User Units function to compensate for the transducer and signal conditioner's scaling and offset.

1. Relate the scale factor of the transducer and/or signal conditioner to its value at one (1) volt.
2. Enter that value (in scientific notation) into the vertical scaler.
3. Add the negative of the offset value into the vertical offset.
4. Enter an appropriate label in the Vertical Units field for the transducer being used.

Example: A current probe and its amplifier output a signal of 0.5 volt per amp with an offset of 0.25 volt. Relate the scale output (0.5 volt per amp) to one volt: $0.5V = 1A$ so $1V = 2A$. Therefore, enter 2 into the Vertical Scaler as 2.000 E 0. Then enter -2.500 E-1 (the negative of 0.25 volt) into the Vertical Offset. Finally, enter 'A' (for amps) into the Units.

Nicolet ISOBE and User Units

The Nicolet ISOBE is a fiber-optic isolated probe. It has an output of ± 1 volt into 50 ohms.

When using the x1 probe, enter the ISOBE transmitter range setting into the vertical scaler.

Example: With the transmitter voltage range set to ± 100 mV, the $\pm 1V$ output from the ISOBE receiver is representing ± 100 mV. Therefore, enter that value into the vertical scaler as 1.000 E-1.

When using an attenuating probe, multiply the probe's attenuation factor by the voltage range of the ISOBE transmitter and then enter that value into the Vertical Scaler field.

Example: If using a x1000 probe on the ± 100 mV scale, enter 1.000 E2 (1000 x 100 mV = 100 = 1.000 E2) into the Vertical Scaler.

Additional Examples

For the following examples, enter the scientific notation values shown.

For a divide by 10 attenuating probe,
Vertical Scaler = 1.000 E 1.
Vertical Offset = 0.000 E 0
Vertical Units = V.

For a divide by 5000 resistor network,
Vertical Scaler = 5.000 E 3.
Vertical Offset = 0.000 E 0
Vertical Units = V.

For a current probe with an output of 0.2 A/div into a 50 mV/div scale,
Vertical Scaler = 4.000 E 0.
Vertical Offset = 0.000 E 0
Vertical Units = V.

For an ISOBE with a x100 probe being used on the ± 100 mV input range,
Vertical Scaler = 1.000 E 1.
Vertical Offset = 0.000 E 0
Vertical Units = V.

For capturing a high voltage waveform on the 12 V scale from an attenuation circuit that divides the measured signal by 7.2 k,
Vertical Scaler = 7.200 E 3
Vertical Offset = 0.000 E 0
Vertical Units = V.

For an acceleration waveform from a signal conditioner with an output of 300 mV/g and an offset of 12.5 mV,
Vertical Scaler = 3.333 E 0
Vertical Offset = -1.250 E-2
Vertical Units = g.

For a force waveform that has a conditioned output of 2.5 mN/div into a Pro scale of 0.2 mV/div. The offset is controlled by the signal conditioner and is assumed to be zero volts.
Vertical Scaler = 1.250 E 1
Vertical Offset = 0.000 E 0
Vertical Units = N.

CHANNEL TITLE

Channel Title allows you to title captured data and display the title on the screen for quick identification. The title can contain up to 40 characters and can be assigned to the channel and/or Save Ref waveform(s).

1. Execute CHANNEL TITLE. The Channel Title display appears (Figure 2).
2. To enter a new title, press the Select button until BLANK is selected and then use the Cursor buttons and TIME knob to enter the new title.

To edit an existing title, press the Select button until the channel has been selected and the channel's title appears. Then use the Cursor buttons and TIME knob to edit the title.

To clear a title, select "BLANK" and then press the channel's ON or SAVE REF button.

3. Press the desired Channel's ON and/or SAVE REF button(s) to store your selection from step 2.

Note: You can enter a single title into any of the Channels or Save Ref's by pressing their ON/SAVE REF buttons and then edit each individual title as required.

For example, storing the title "Channel 1 - Impulse" into channels 1 and 2 and then editing channel 2 to read "Channel 2 - Impulse" allows you to quickly title channel 2 without having to reenter the entire title.

4. Press the Menu button to return to the waveform display.

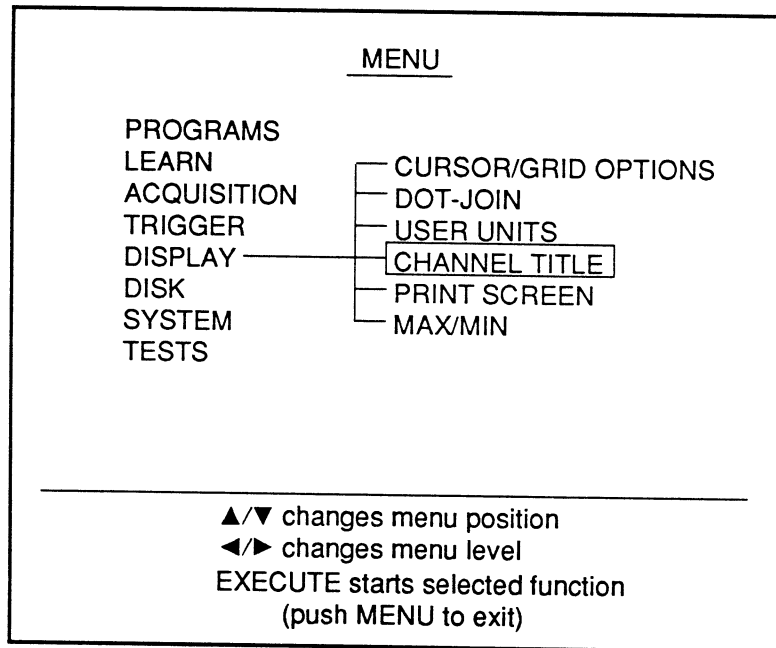

Figure 1 - Channel Title

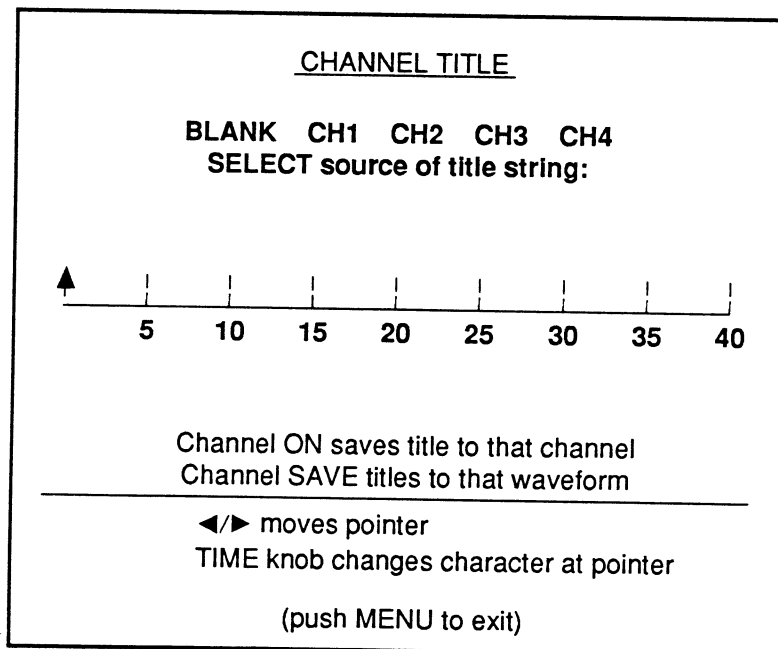

Figure 2 - Channel Title Display

PRINT SCREEN

Print Screen allows the instrument to send the display screen information to a dot matrix printer for a hard copy record.

Important: The printer must be EPSON FX compatible.

1. Execute PRINT SCREEN. The Print Screen prompt display appears (Figure 2).

Note: Use the PRINTER OUTPUT function to select which rear panel port and the printer type you will be using (see *Chapter 21*). The current selections from the PRINTER OUTPUT function are highlighted in Figure 2.

2. Press the Execute button. The front panel PLOT button has now been redefined to drive a dot matrix printer.
3. Connect the printer to which ever port was selected by the PRINTER OUTPUT. See *Chapter 24*.
4. When the printer is connected to the proper port and ready to receive data, press the Plot button.

Note: When the Plot button has been redefined for use with a dot matrix printer, a check mark will be present next to PRINT SCREEN (Figure 1). If no check mark is present, then the Plot button has been defined for use with a digital plotter.

Important: Once the Plot button has been redefined for use with a dot matrix printer, it will remain in this configuration. To redefine the Plot button for use with a digital plotter, select PRINT SCREEN and then press the Execute button. The check mark will be removed from PRINT SCREEN (Figure 1).

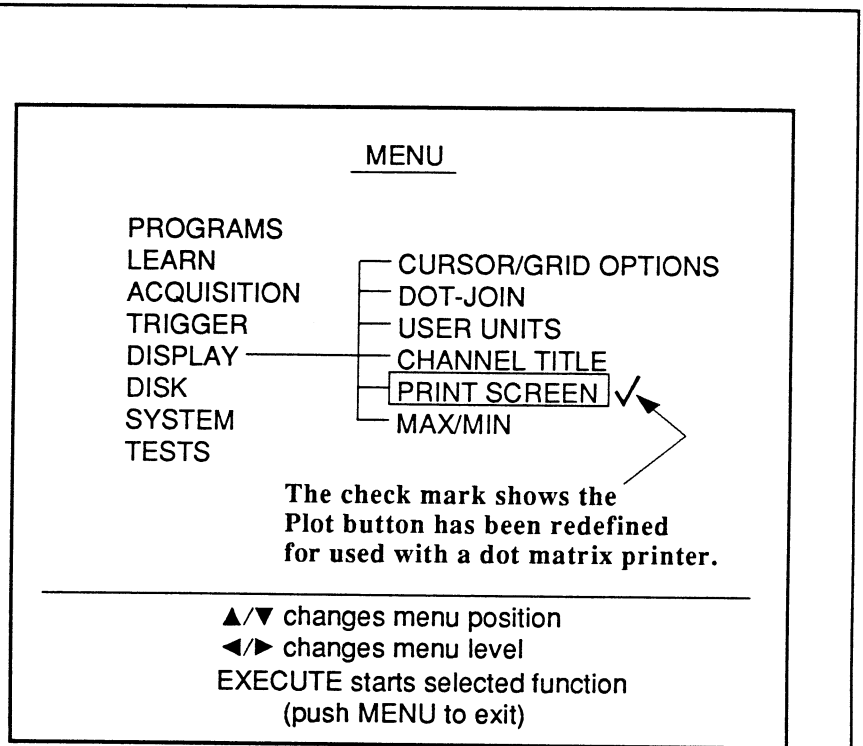

Figure 1 - Print Screen. A check mark next to PRINT SCREEN means the Plot button has been redefined for use with a dot matrix printer. If no check mark is present, the Plot button is configured for use with a digital plotter.

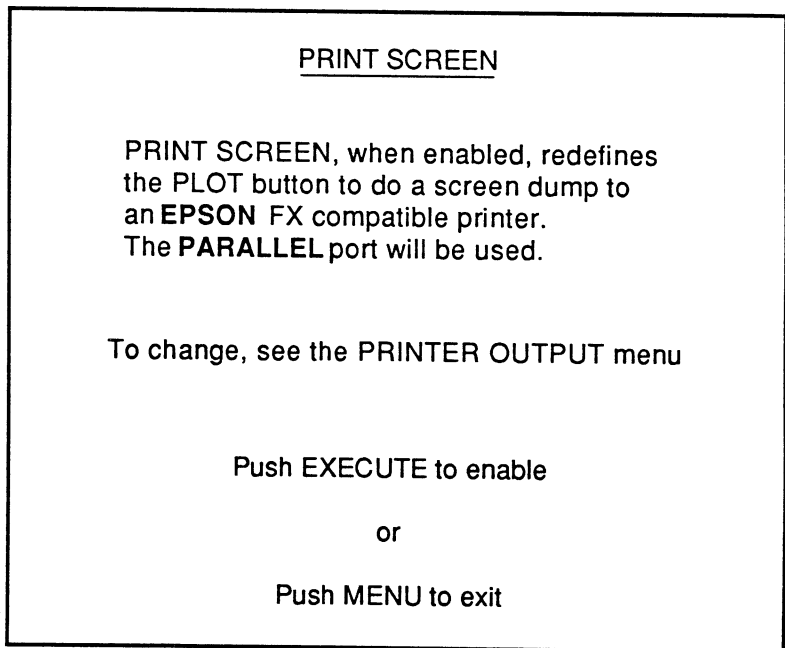

Figure 2 - Example Print Screen Display

MAX/MIN

Max/Min selects the maximum and minimum voltage values in each bin for display. If Max/Min is disabled, the first voltage value in each bin is selected for display.

1. Execute MAX/MIN.
2. Set up the desired Sweep Length, Time, Volts, etc.
3. Capture the signal.

Example

Figures 2 and 3 show each bin contains four samples.

Note: The number of bins is determined automatically by the instrument based on the Time and Sweep Length settings.

Figure 2 illustrates the first voltage value in each bin is always selected for display when Max/Min is disabled.

Figure 3 illustrates the same signal after enabling Max/Min. The instrument now selects and displays both the maximum and minimum voltage values in each bin. The instrument then fills in the remainder of the data points automatically to enhance the waveform display.

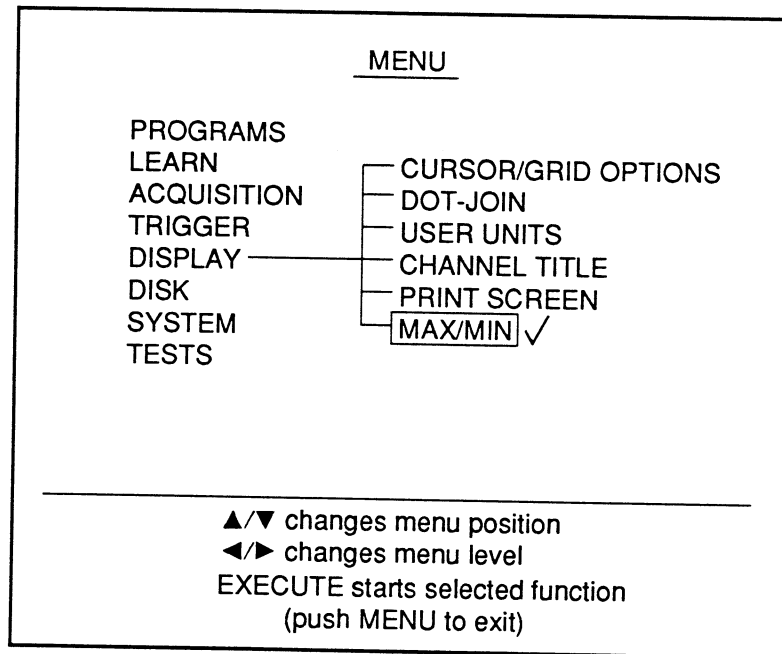

Figure 1 - Max/Min Screen. A check mark next to MAX/MIN means it is enabled.

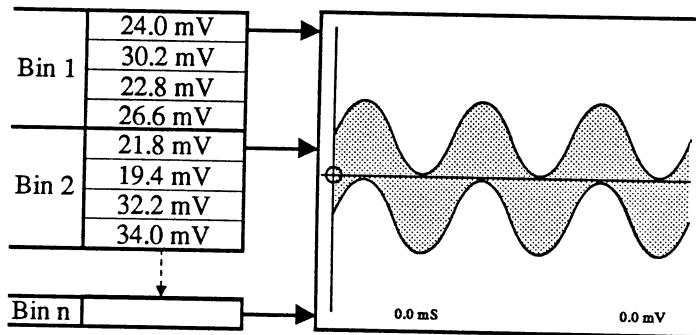

Figure 2 - Without Max/Min enabled, the first point in each bin is displayed.

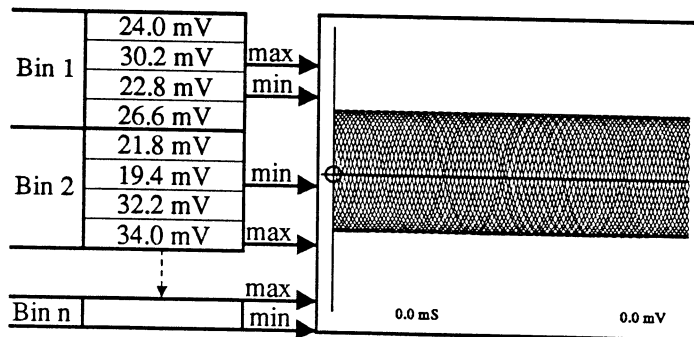

Figure 3 - With Max/Min enabled, max/min points in each bin are displayed.

Chapter 20

THE DISK

MENU

Store Setup	20-2
Recall Setup	20-3
Initialize MSO	20-4
Copy File	20-5
Delete File	20-6
Format Disk	20-7
Directory	20-8
Plot From Disk	20-9

Disk provides a means by which the instrument's front panel control settings can be stored on a diskette and then recalled at a later time for immediate use.

This menu is also used to copy or delete files, format new diskettes, initialize the PRO Disk (INITIALIZE MSO) if it was not powered up at the same time as the oscilloscope, and review the contents of each directory.

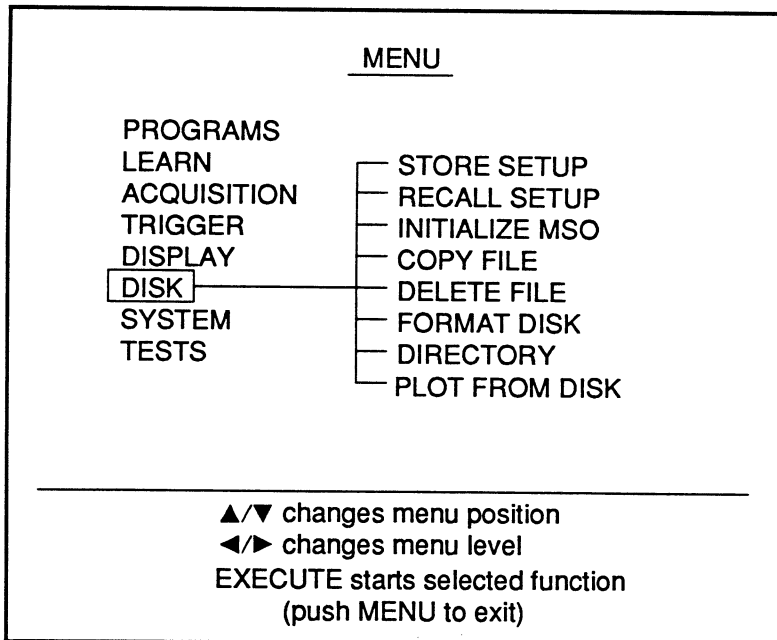

Figure 1 - The DISK menu display

STORE SETUP

Store Setup allows you to store the current front panel settings on a diskette for recall at a later time.

Note: Refer to *Chapter 23, Floppy Drives*, for descriptions of the path, directories, files, etc.

1. Execute STORE SETUP. The Store Settings screen appears (Figure 2).

Note: The Select button is used to determine whether the cursor buttons will change the "drive/path" or the "file number." If necessary, press the Select button until "CURSORS change drive/path" appears towards the bottom of the screen.

2. To change the drive/path, press the Select button and then use the Cursor buttons to select the drive/path.
 A = Internal 3.5" floppy drive
 B = First external floppy drive
 C = Fixed hard disk
 D = Bernoulli cartridge
 E = Future (not used)
 F = Second external floppy drive
3. When the desired drive/path has been selected, press the Select button and then use the Up/Down Cursor buttons to select the file name under which you wish to store the setup.
4. Press the Execute button to store the current front panel settings.

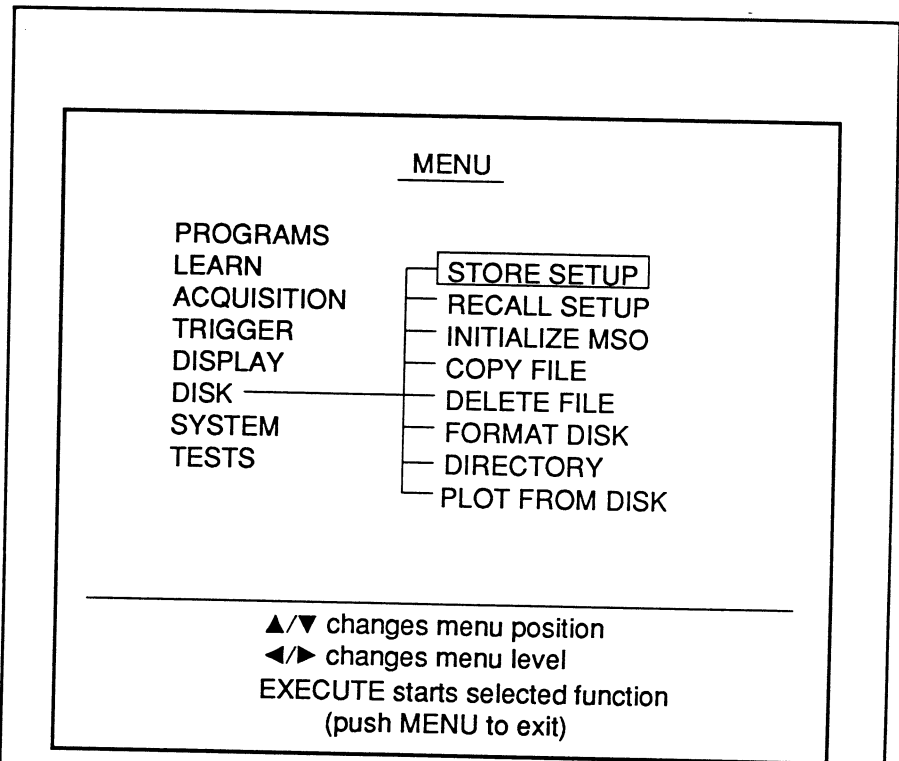

Figure 1 - Store Setup/Recall Setup

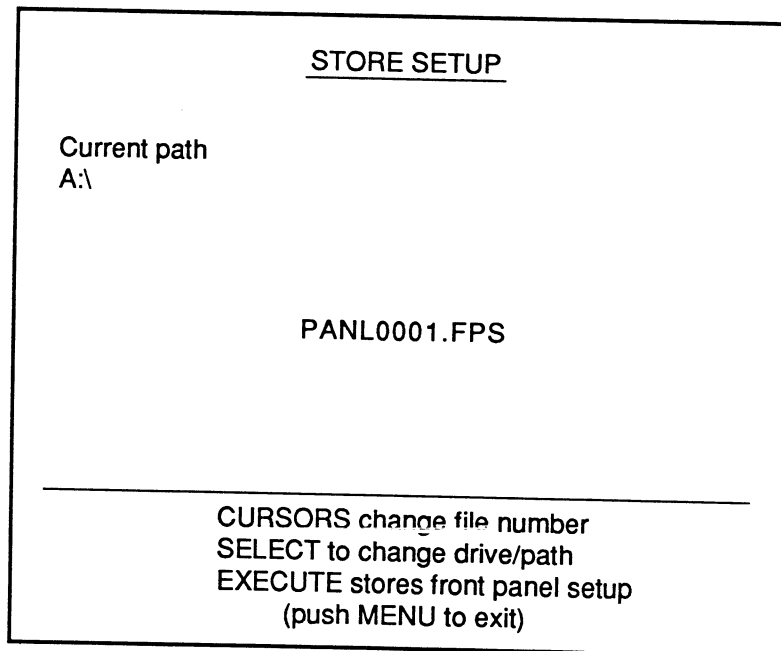

Figure 2 - Store Setup Screen

RECALL SETUP

Recall Setup allows you to recall a specific front panel setting previously stored on disk using the Store Setup function.

Note: Refer to *Chapter 23, Floppy Drives*, for descriptions of the path, directories, files, etc.

1. Execute RECALL SETUP. The Recall Settings screen appears (Figure 2).

Note: The Select button is used to determine whether the cursor buttons will change the "drive/path" or the "file number." If necessary, press the Select button until "CURSORS change drive/path" appears towards the bottom of the screen.

2. To change the drive/path, press the Select button and then use the Cursor buttons to select the drive/path.
 - A = Internal 3.5" floppy drive
 - B = First external floppy drive
 - C = Fixed hard disk
 - D = Bernoulli cartridge
 - E = Future (not used)
 - F = Second external floppy drive
3. When the desired drive/path has been selected, press the Select button and then use the Up/Down Cursor buttons to move the pointer over the file name you wish to recall.
4. Press the Execute button to recall the front panel settings.

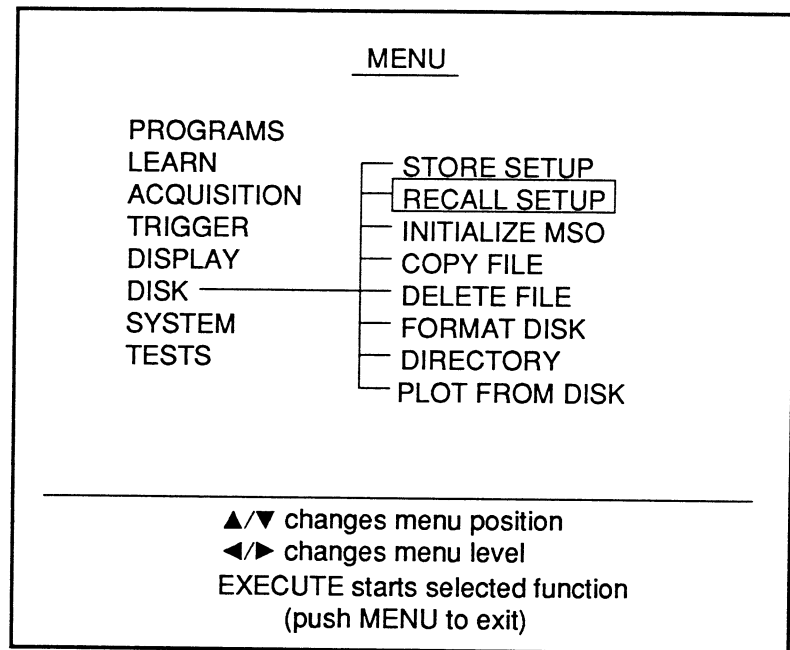

Figure 1 - Recall Setup

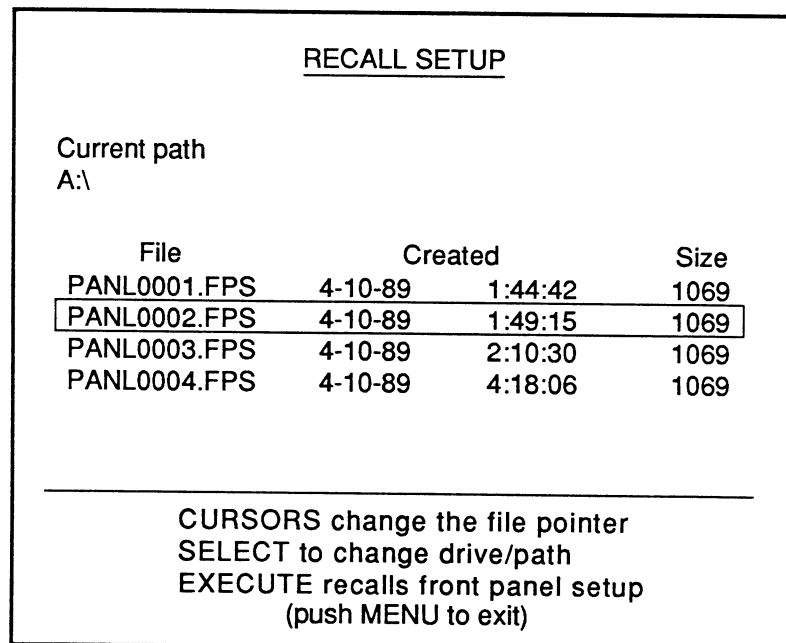

Figure 2 - Recall Setup Screen

COPY FILE

Copy File is used to copy a file from one diskette to another diskette.

Note: Ensure that the diskette that is going to receive the selected file is formatted for your instrument.

1. Execute COPY FILE. The Copy File screen appears (Figure 2).
2. To change the drive/path, press the Select button until "CURSORS change drive/path" appears towards the bottom of the screen and then use the Cursor buttons to select the drive/path.
 A = Internal 3.5" floppy drive
 B = First external floppy drive
 C = Fixed hard disk
 D = Bernoulli cartridge
 E = Future (not used)
 F = Second external floppy drive
3. When the desired drive/path has been selected, press the Select button and then use the Up/Down Cursor buttons to move the pointer over the file name to be copied.
4. Press the Execute button. A second Copy File screen will appear with the selected file name.
5. Use the Cursor buttons to select which drive and directory on that drive will copy the selected file.
 A = Internal 3.5" floppy drive
 B = First external floppy drive
 C = Fixed hard disk
 D = Bernoulli cartridge
 E = Future (not used)
 F = Second external floppy drive
6. Press the Execute button.
Note: If the selected path already contains a file name identical to the one you are trying to copy, you will be prompted that the file already exists. If the file is to be overwritten, press Execute; if not, press the Menu button.

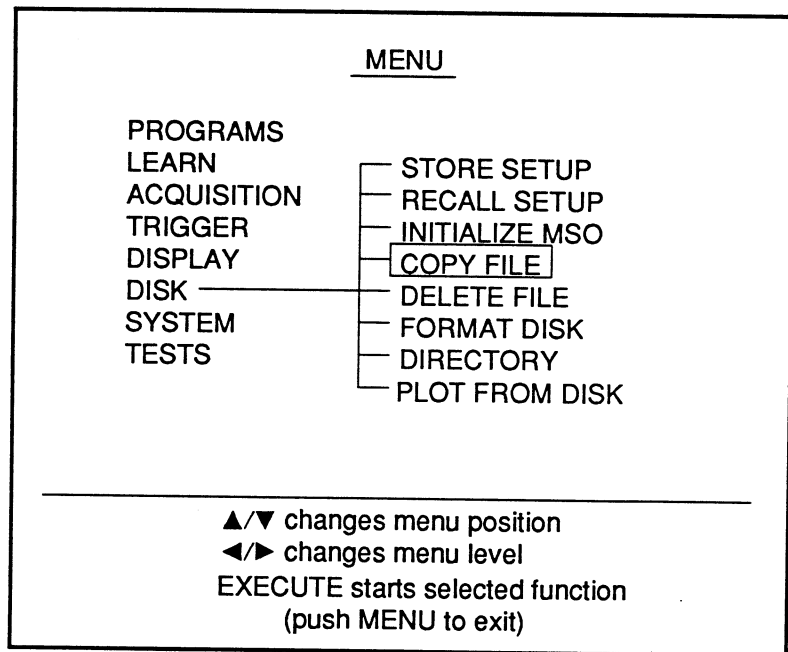

Figure 1 - Copy File

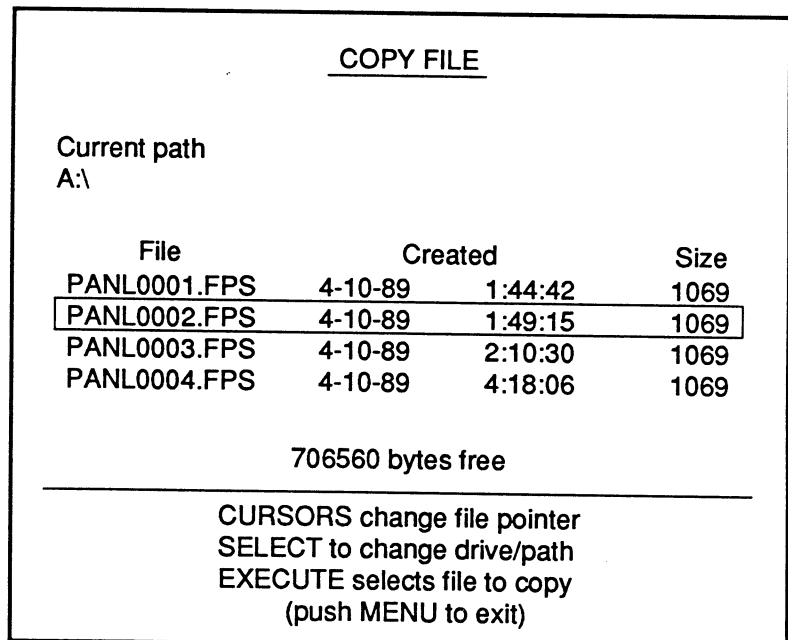

Figure 2 - Copy File Screen

DELETE FILE

Delete File is used to remove a file from a diskette when it is no longer needed.

Note: Refer to *Chapter 23, Floppy Drives*, for descriptions of the path, directories, files, etc.

1. Execute DELETE FILE. The Delete File screen appears (Figure 2).

Note: The Select button is used to determine whether the cursor buttons will change the "drive/path" or the "file pointer." If necessary, press the Select button until "CURSORS change drive/path" appears towards the bottom of the screen.

2. To change the drive/path, press the Select button and then use the Cursor buttons to select the drive/path.

A = Internal 3.5" floppy drive
 B = First external floppy drive
 C = Fixed hard disk
 D = Bernoulli cartridge
 E = Future (not used)
 F = Second external floppy drive

3. When the desired path has been selected, press the Select button and then use the Up/Down Cursor buttons to move the pointer over the file name you wish to delete.
4. Press the Execute button. The file is now deleted from the disk.

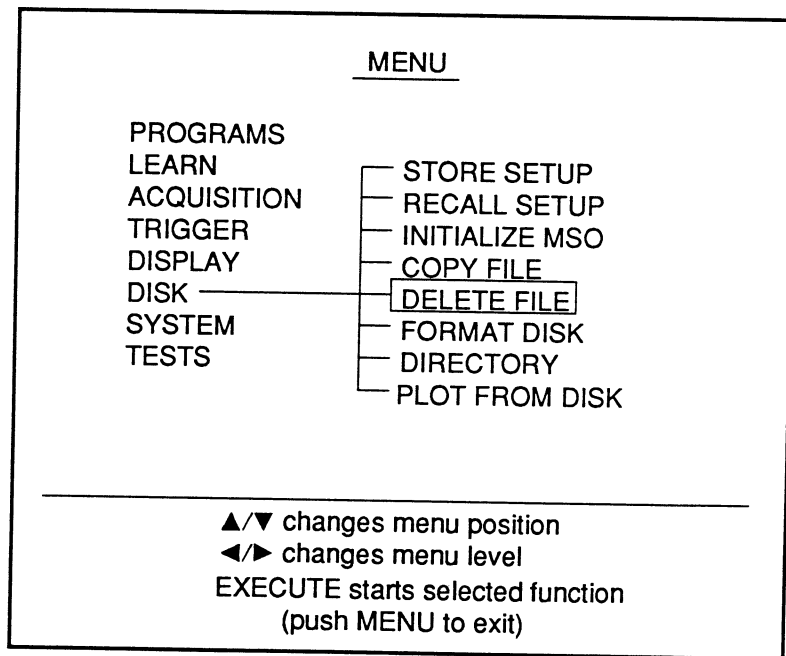

Figure 1 - Delete File

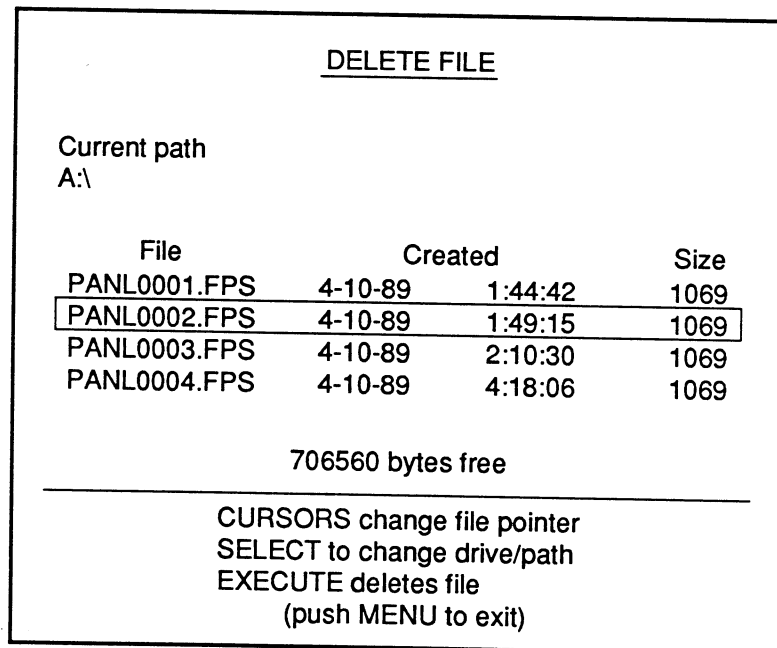

Figure 2 - Delete File Screen

DIRECTORY

Directory allows you to view the contents of each directory.

1. Execute Directory. The Directory display appears (Figure 2).

Note: The Select button is used to determine whether the cursor buttons will change the "drive/path" or the "page directory." If necessary, press the Select button until "CURSORS change drive/path" appears towards the bottom of the screen.

2. Use the Select button to select the desired drive/path.

- A = Internal 3.5" floppy drive
- B = First external floppy drive
- C = Fixed hard disk
- D = Bernoulli cartridge
- E = Future (not used)
- F = Second external floppy drive

3. Press the Select button.
4. Press the Cursor buttons to page through the selected directory.

Note: To return to the first page, press the Up cursor button.

5. Press the Menu button to return to the waveform display.

Note: Executing the Directory function again will return you to the same drive/path and page that were displayed when the Menu button was pressed in step 5 above.

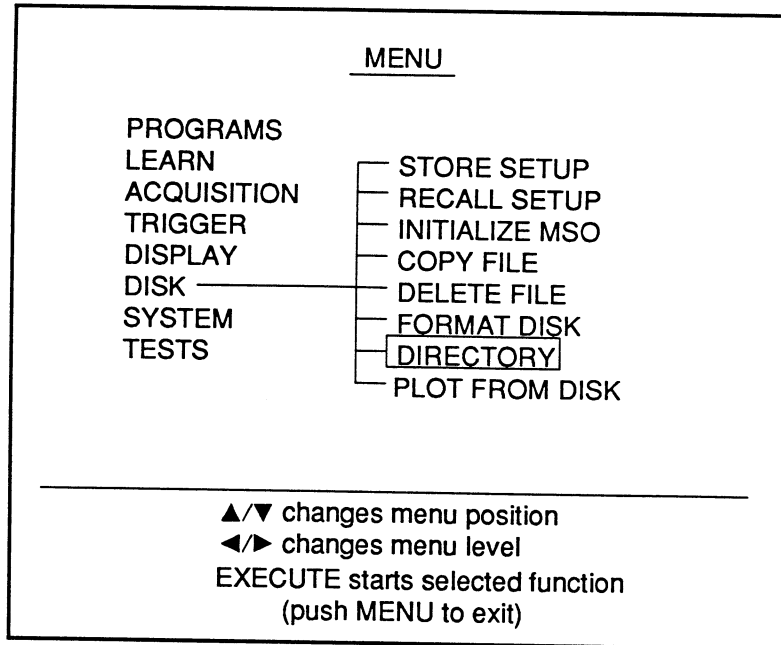

Figure 1 - Directory

DIRECTORY

Current path
A:\

File	Created	Size
PANL0001.FPS	4-10-89 1:44:42	1069
PANL0002.FPS	4-10-89 1:49:15	1069
PANL0003.FPS	4-10-89 2:10:30	1069
PANL0004.FPS	4-10-89 4:18:06	1069

706560 bytes free

CURSORS page directory
SELECT to change drive/path
(push MENU to exit)

Figure 2 - Directory Display

PLOT FROM DISK

Plot From Disk allows you to plot a waveform file which was previously stored to disk using the **Plot To Disk** screen, see **Plotting To Disk** in *chapter 24*.

1. Execute **Plot From Disk**. The **Plot File Name** display appears (Figure 2).

Note: If the message "Can't plot to file" appears (Figure 2), press the **Menu** button and then the **Plot** button. Execute 'Change Plot Parameters' and set the **Plot Used** parameter to **RS232**, **IEEE488**, or **PARALLEL** as appropriate. Next, press the **Plot** button and then return to step 1 above.

2. Use the **Select** button to select the desired drive/path.

- A = Internal 3.5" floppy drive
- B = First external floppy drive
- C = Fixed hard disk
- D = Bernoulli cartridge
- E = Future (not used)
- F = Second external floppy drive

3. Press the **Select** button.
4. Press the **Cursor** buttons to page through the selected directory.

Note: To return to the first page, press the **Up** cursor button.

5. Press the **Execute** button to start plotting the selected file.

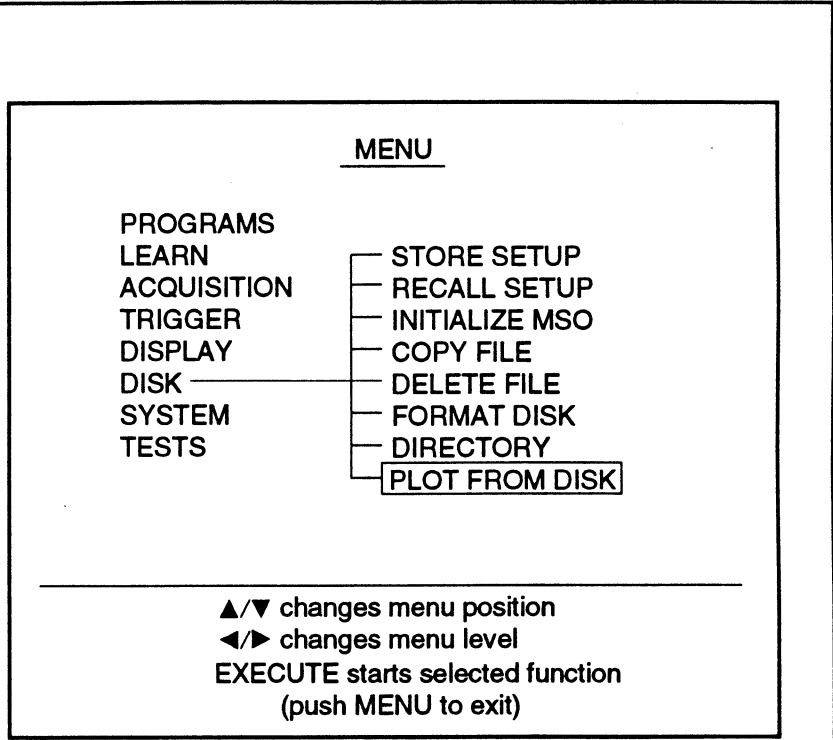

Figure 1 - Plot From Disk

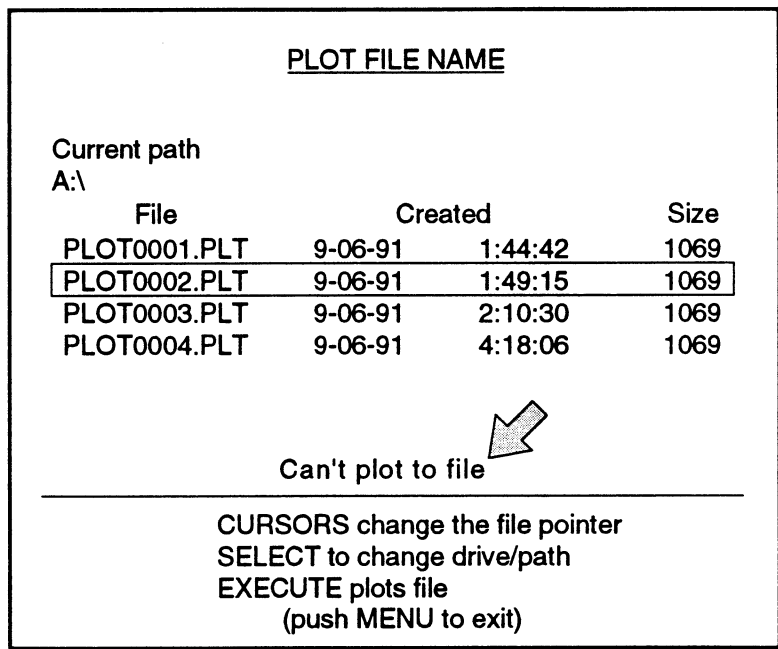

Figure 2 - Plot File Name Screen with

Chapter 21

THE SYSTEM

MENU

Setup To Ram	21-2
Setup From Ram	21-2
I/O Parameters	21-3
Printer Output	21-4
Set Date/Time	21-5
Beeper	21-6
High Res Auto Set-up	21-7
About	21-8

The System Menu allows you to temporarily store the front panel settings in RAM for later recall and setup the GPIB and RS-232 parameters required to communicate with external devices.

It is also used to set the internal calendar and clock which can be used to record the date and time that certain operations were performed.

An audio beeper can be turned on to alert you when attempting an "illegal" action and the About function provides information about each of the channels.

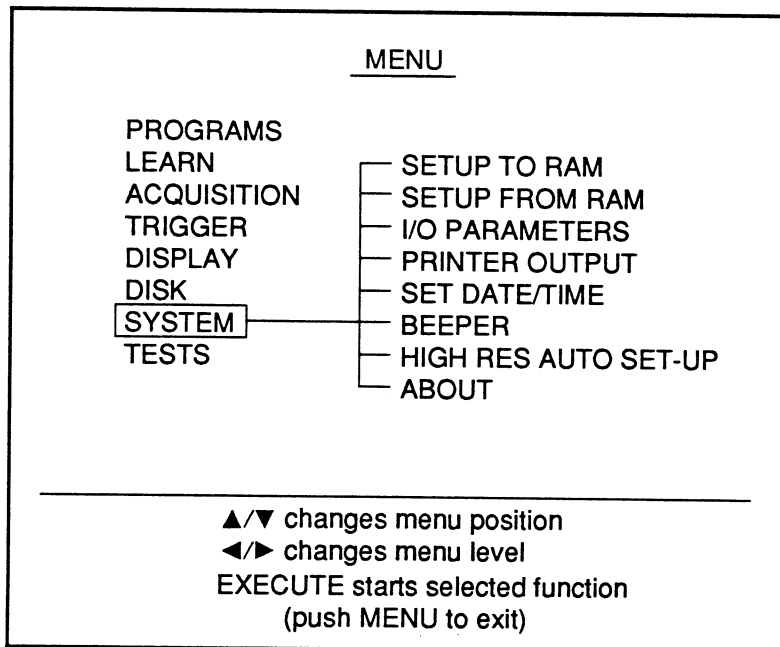

Figure 1 - The SYSTEM menu display

SETUP TO RAM & SETUP FROM RAM

Setup To RAM is used to store the current front panel settings temporarily in memory for later recall.

Setup From RAM is used to recall the front panel setting from the memory.

These two functions allow you to experiment with different front panel settings and then quickly return to the original settings.

Storing the Front Panel Settings to RAM

1. Execute SETUP TO RAM. The Setup To Ram screen appears (Figure 2).
2. Use the Up/Down Cursor buttons to select under which file number (1, 2, or 3) the front panel settings will be stored.
3. Press the Execute button.

Recalling the Front Panel Settings from RAM

1. Execute SETUP FROM RAM. The Setup From Ram screen appears. This screen is similar in appearance to the Setup To Ram Screen.
2. Use the Up/Down Cursor buttons to select which file number's (1, 2, or 3) settings will be recalled.

Note: File number 4 is a temporary file for storing the current setup before recalling files 1, 2, or 3. Files 1, 2 and 3 are battery backed. File 4 will be cleared if power is removed from the instrument.

3. Press the Execute button.

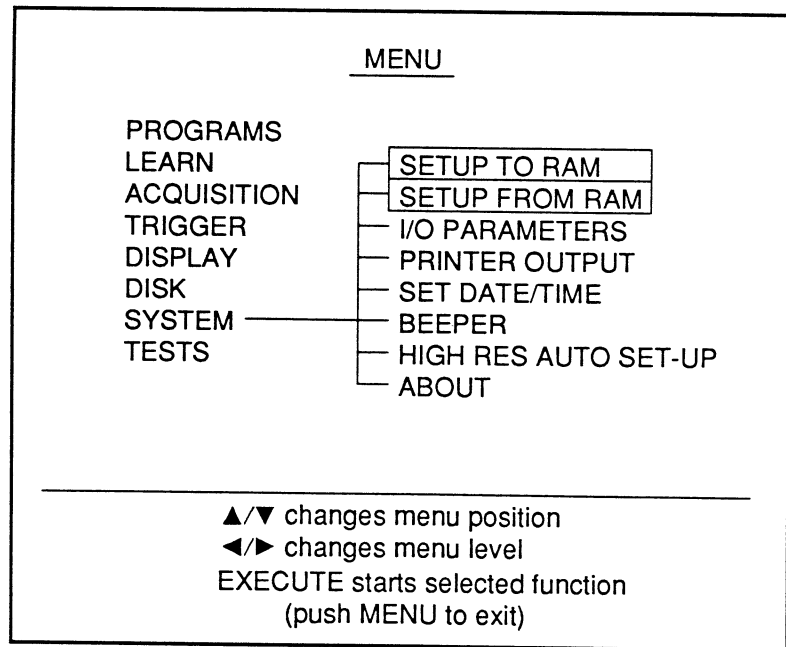

Figure 1 - Setup To Ram/Setup From Ram

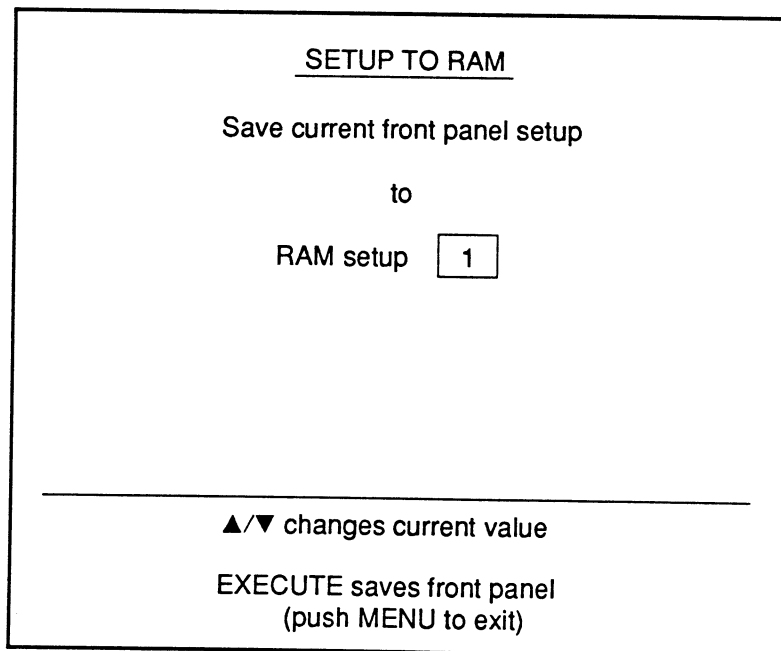

Figure 2 - Setup To Ram Screen

I/O PARAMETERS

I/O Parameters is used to select whether the RS-232 or GPIB ports will be enabled and then select the parameter settings required to communicate with an external device.

1. Execute I/O PARAMETERS. The I/O Parameters screen appears (Figure 2).
2. Use the Up/Down Cursor buttons to move the parameter selection box and the Left/Right Cursor buttons to change the parameter setting. Table 1 tabulates the possible settings that can be entered.
3. When all of the parameters have been set, press the Execute button.

RS232 Parameters	
Speed:	110, 300, 600, 1200, 2400, 4800, 9600, 19200
Parity:	None, Even, Odd, Mark (1), Space (0)
Data Length:	7 bits, 8 bits
Stop:	1 bit, 2 bits
CTS/RTS HANDSHAKE:	Off, On
Turnaround Delay:	0 mS - 255 mS
IEEE488 Parameters	
Address:	0 - 30

Table 1 - Parameter Settings

Note: Turnaround Delay is the minimum time that the I/O commands must wait following a command requiring a response.

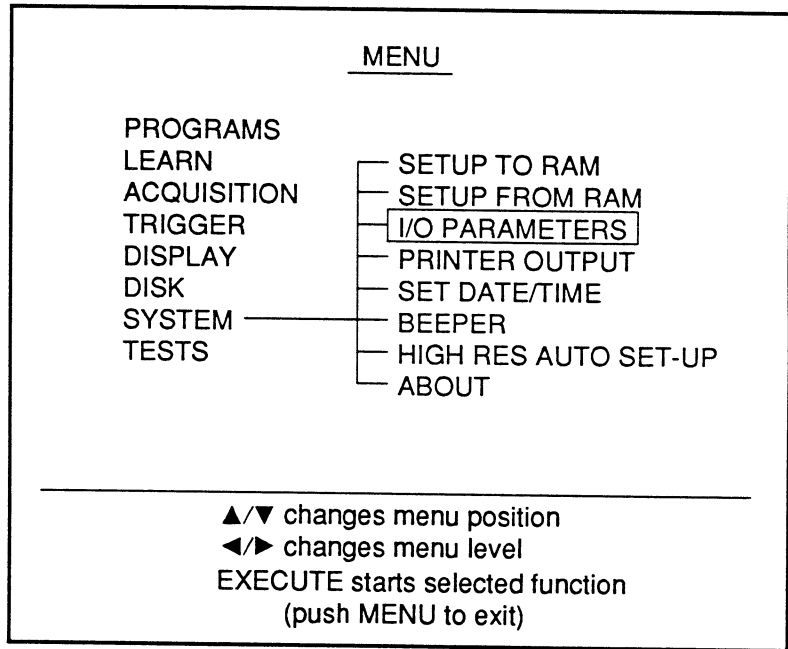

Figure 1 - I/O Parameters

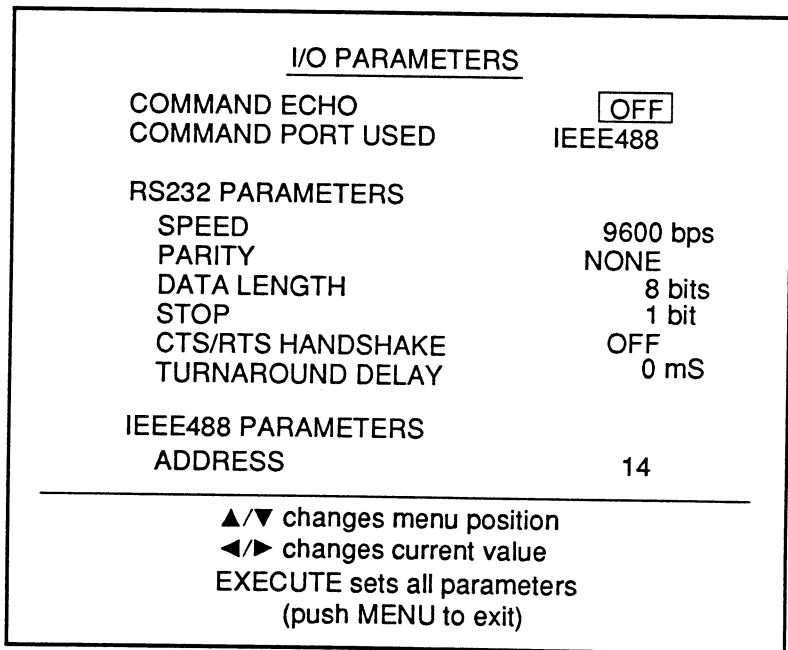

Figure 2 - I/O Parameters Screen

PRINTER OUTPUT

Printer Output is used to select which port will be used on the rear of the instrument to output data to a printer.

1. Execute PRINTER OUTPUT. The Printer Output selection screen appears (Figure 2).
2. Use the Cursor buttons to select the desired port, RS232 or PARALLEL
3. Press the Execute button.

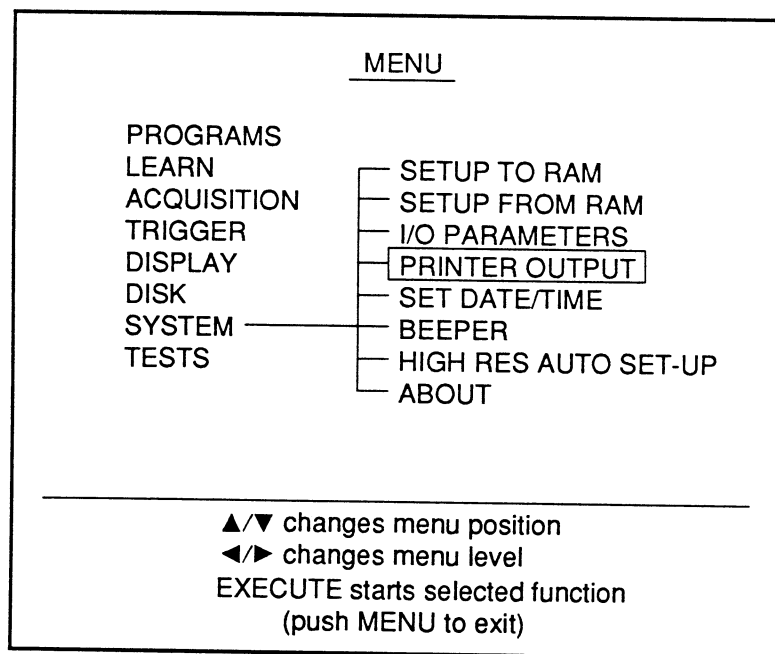

Figure 1 - Printer Output

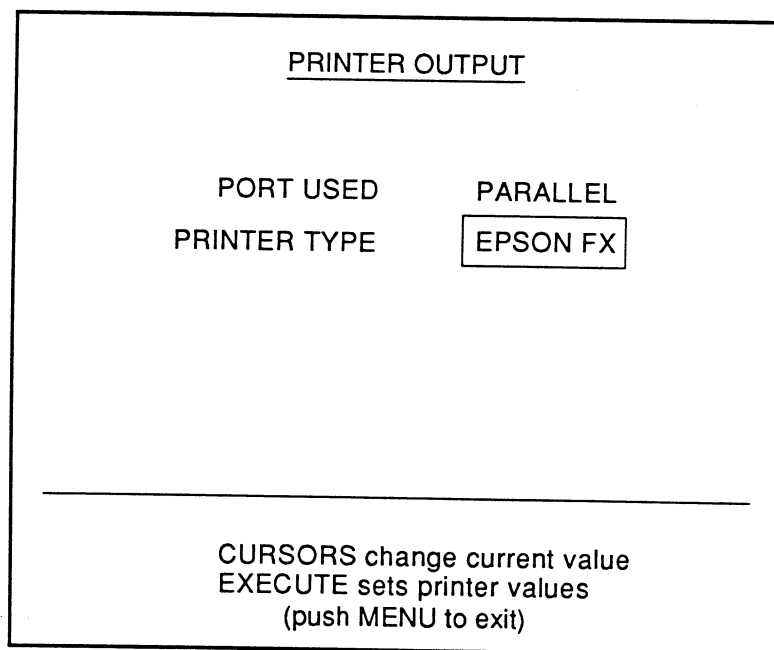

Figure 2 - Printer Output Selection Screen

BEEPER

Beeper allows you to enable an audio alarm to sound if you attempt to perform an "illegal" action, or silence the alarm by disabling the beeper.

1. Execute BEEPER. A check mark will appear next to BEEPER when the audio alarm has been enabled. The alarm is disabled if there is no check mark.
2. Press the Menu button to return to the waveform display.

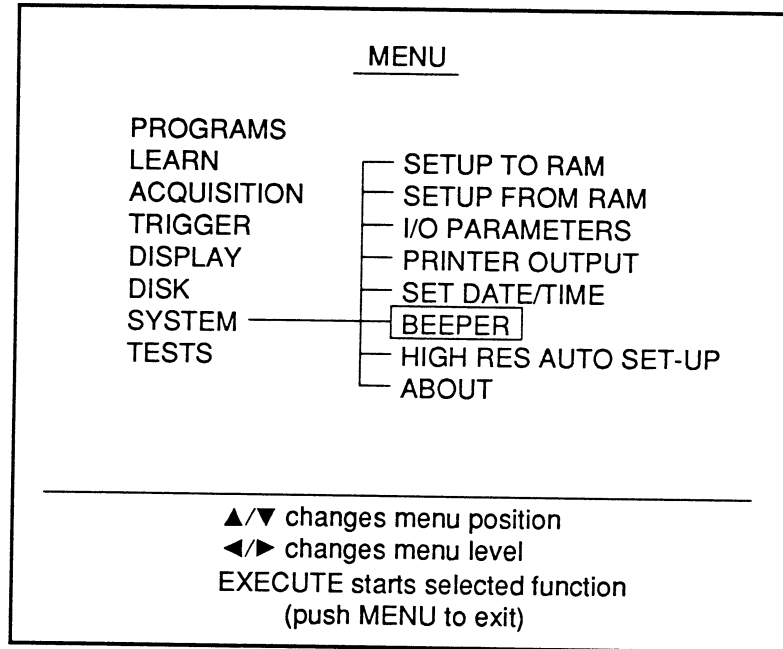

Figure 1 - Beeper Enable

HIGH RES AUTO SET-UP

High Res Auto Set-Up causes the instrument to provide a full screen display of the captured data automatically when the Auto Set-up button is pressed. See *Chapter 13*, Auto Set-up for a description of the Auto Set-up feature.

Note: You will not notice any effect if only one channel is turned on.

This function is turned on when a check mark is present at the end of HIGH RES AUTO SET-UP.

1. Execute HIGH RESOLUTION AUTO SET-UP.
2. Press the Menu button to return to the waveform display.

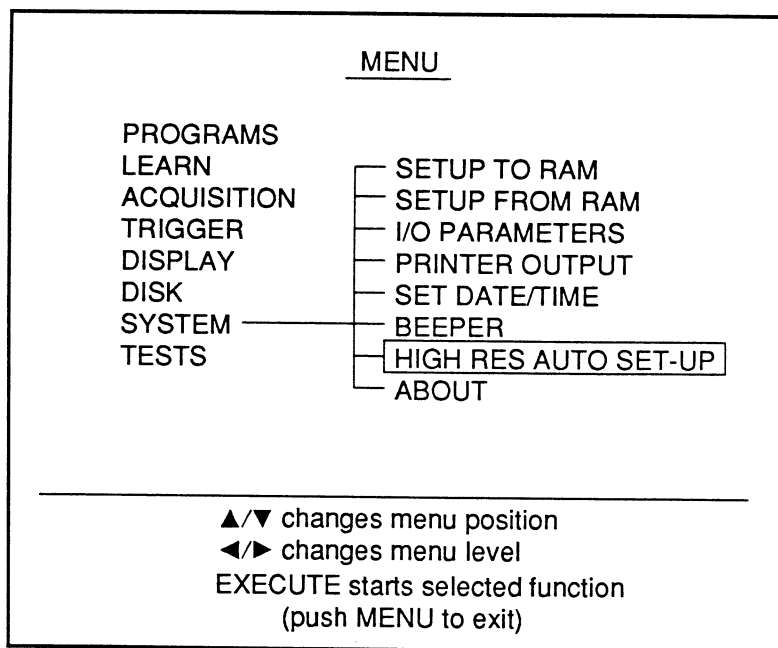

Figure 1 - High Res Auto Set-up

ABOUT

About provides information about the digitizers installed in the instrument. It also includes the PROM version, date and time.

1. Execute ABOUT. The About screen appears (Figure 2).

The example in Figure 2 shows that two digitizers have been installed and they are 12 bit, 10 MHz maximum rate digitizers.

2. Press the Menu button to return to the waveform display.

Note: The Date and Time are set via the SET DATE/TIME function described earlier in this chapter.

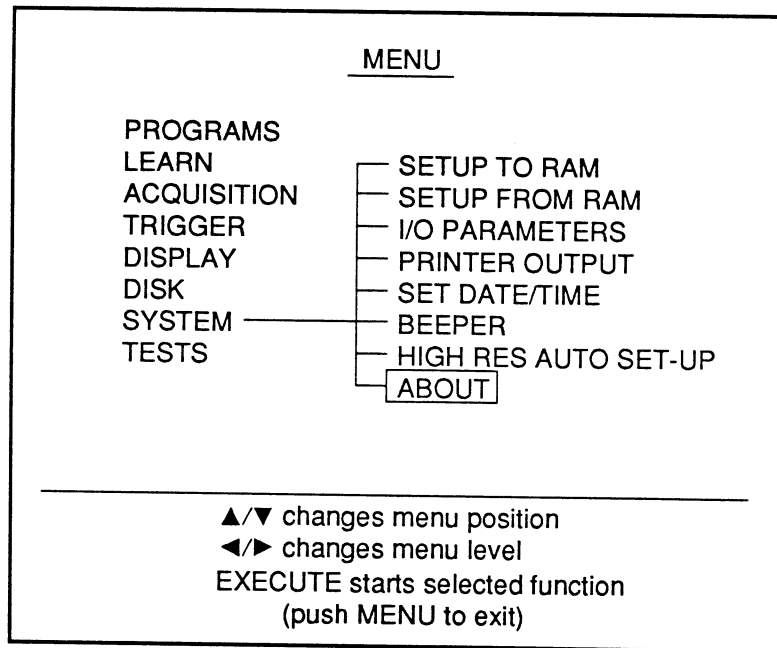

Figure 1 - About

System Configuration

CHAN#	DIGITIZER DESCRIPTION	
1	12 bit / 10 MHz	Ver X
2	12 bit / 10 MHz	Ver X
3	NO CHANNEL	
4	NO CHANNEL	
	<u>PROM ver</u> X.XXXXXX	<u>ADC Ctrl</u> Rev X
<u>FPU</u> YES	<u>CPU</u> XXX.x Rev x	<u>µCODE</u> X.XX
	DATE 09/05/91	TIME 15:42:12
(Push CHANNEL ON or SAVE REF to exit)		

Figure 2 - About Information Screen

Chapter 22

THE TESTS

MENU

Front Panel Test _____ 22-2

The **Tests Menu** allows you to confirm that the instrument's front panel controls are functioning (electrically) properly.

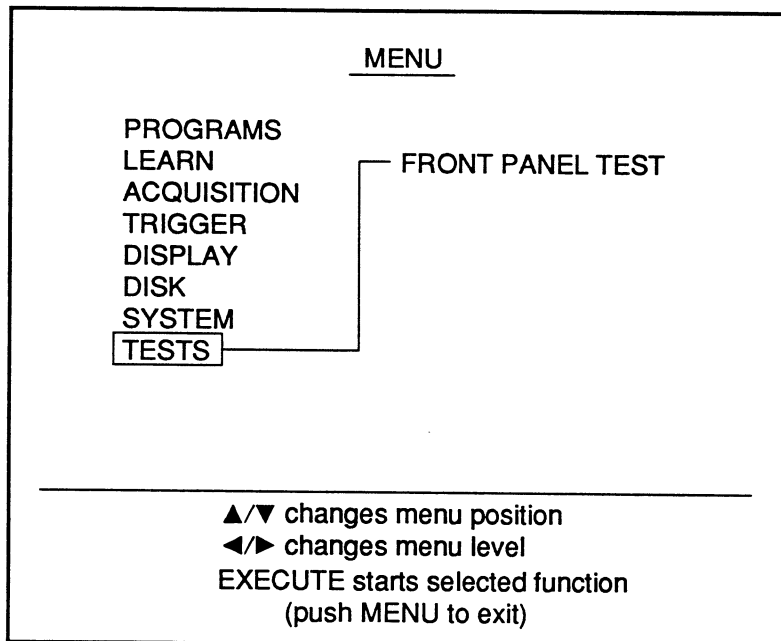

Figure 1 - The TESTS menu display

FRONT PANEL TEST

Front Panel Test is used to confirm the front panel controls are operating electrically proper.

1. Execute FRONT PANEL TEST. The Front Panel Test screen appears (Figure 2).
2. Press each button and rotate each variable control while observing the Front Panel Test screen.

The corresponding front panel control on the screen should brighten as each button is pressed and variable control is rotated. If a button/control does not brighten on the screen, then it is possibly defective and further inspection is required.

To return to the waveform display, hold in any three single operation buttons (e.g., any three of the Cursor buttons).

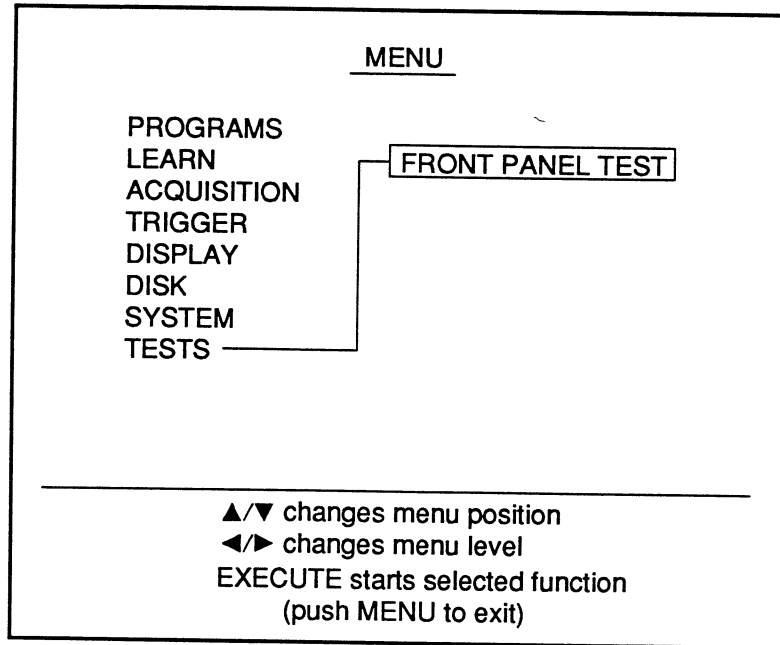

Figure 1 - Front Panel Test

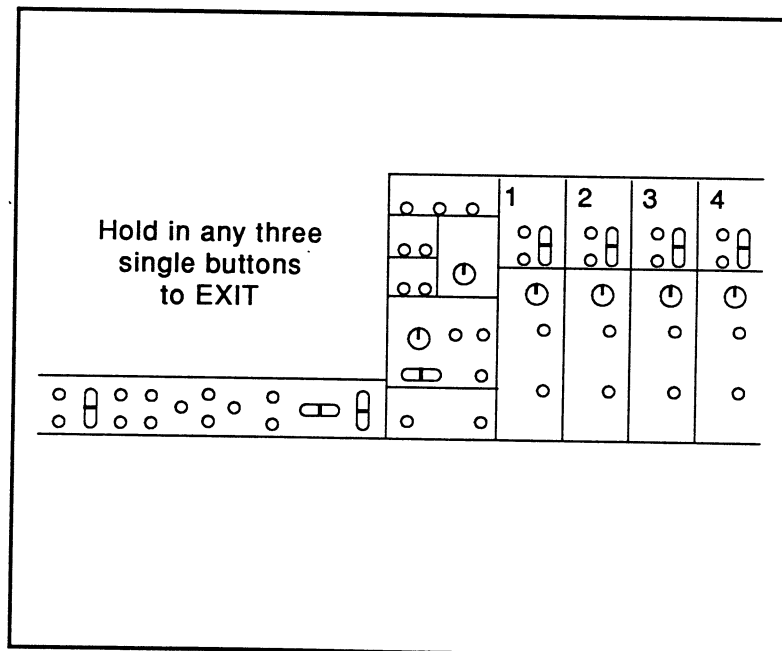

Figure 2 - Front Panel Test Screen

Chapter 23

THE

DISK DRIVES

The Diskette Format	23-3
MS DOS Format	23-3
Reading Diskettes in an IBM- PC	23-3
The Drives, Directories & Waveform Files	23-4
The Pathname	23-4
The Operation	23-4
The Drive Specifier	23-4
The Root Directory	23-5
The Subdirectories	23-5
The Waveform File Name	23-5
Protecting Data on the Diskette	23-6
Loading the Diskette	23-6
Formatting New Diskettes	23-6
Storing Waveforms on Diskette	23-7
Initiating/Aborting the Store Mode	23-7
The Default File	23-8
• Bypassing the Default File	23-8
• Overwriting an Existing File	23-8
Single/Multiple Waveform Displays	23-9
The Store Procedure	23-10
Recalling Waveforms for Display	23-11
Selecting the Destination Channel	23-11
Initiating the Recall Mode	23-12
Selecting a File for Recall	23-12
Executing the Recall Mode	23-12
Aborting the Recall Mode	23-12
The Recall Procedure	23-12
The Pro Disk	23-13
Floppy Disk Drive and Fixed Hard Disk	23-14
Bernoulli Cartridge Drive	23-15
Removable Optical Disk Drive	23-16
Mounting the Pro Disk to the Pro Series	23-17

The disk drives are used to store and recall waveforms, store and recall front panel setups, and copy and delete files. Any floppy disk drive can be selected to format new floppy diskettes.

This chapter describes how to store waveforms on the disk drives for later recall. Data stored on floppy disks can be read by other devices having the same format and file structure.

Also refer to *Chapter 20* for descriptions on the following resident functions accessed via the Menu button:

- FORMAT DISK
- STORE SETUP
- RECALL SETUP
- COPY FILES
- DELETE FILE
- INITIALIZE MSO
- DIRECTORY

Note: The external disk drives in the Pro Disk operate the same as the internal floppy disk drive. To simplify the following descriptions, the internal floppy drive will be used in the examples.

Important: The original manufacturer recommends that the Bernoulli heads be cleaned at least every 500 power-on-hours for proper maintenance and operation.

Drive Designators

- A: Internal 3.5" floppy drive
- B: First external floppy drive
- C: Fixed hard disk
- D: Bernoulli cartridge/Removable optical disk
- E: Future (not used)
- F: Second external floppy drive

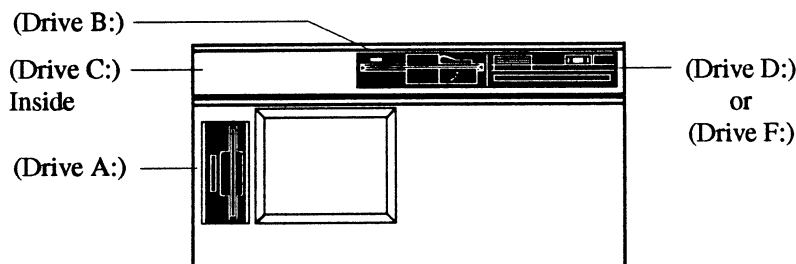

THE DISKETTE FORMAT

The 3-1/2" diskette is a 720 kilobyte (or 1.44 megabyte) formatted, double-sided, high density, soft sector diskette (see Figure 1).

The 5-1/4" diskette is a 1.2 megabyte formatted, double-sided, high density, soft sector diskette.

The diskettes can be formatted in either the internal drive or external Pro Disk drive using the resident Format Disk function accessed via the Menu button (see *Chapter 20*, Format Disk).

Note: You can also format the diskettes on a PC for use with your instrument.

All disks are formatted with the standard MS DOS file structure.

The MS DOS format was chosen for this instrument so that data records can be easily transferred to MS DOS compatible devices (such as IBM PC's and IBM PC Compatibles) for data analysis.

Reading Diskettes in an IBM-PC

Sample programs to read diskettes in an IBM-PC have been supplied with your instrument.

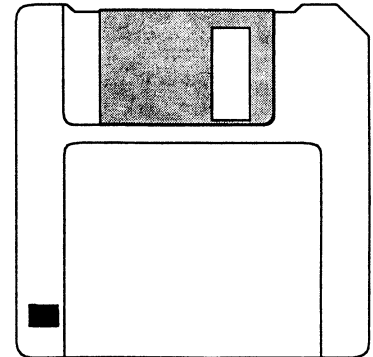

720 kilobyte diskette

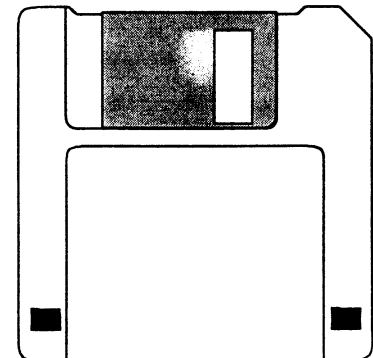

1.44 megabyte diskette

Figure 1 - Identifying the 3-1/2 inch diskettes.

DRIVES, DIRECTORIES AND WAVEFORM FILES

Your instrument automatically creates root directories and subdirectories when the diskette is formatted (see Figure 1).

Before discussing the actual Store and Recall operations, it will be helpful to discuss the terminology that will be used to describe the various drives, directories and file names.

When a diskette is formatted on your instrument, it is automatically assigned a ROOT directory and five (or twenty) subdirectories (Figure 1). File names can be stored under any of the directories for later recall.

Drives A, B & F	Drives C & D
ROOT <ul style="list-style-type: none"> DIR1 DIR2 DIR3 DIR4 DIR5 	ROOT <ul style="list-style-type: none"> DIR1 DIR2 DIR3 DIR4 DIR5 ↓ DIR20

Figure 1: Directories created accordingly for the drives being formatted (see Drive Specifier at right).

The Operation

You will be prompted as to whether data will be either "stored" (Figure 2) or "recalled," depending upon whether Store or Recall was pressed.

The Pathname

Figures 2 and 3 illustrate a sample pathname describing the location in which file WAVE0001.WFT will be stored.

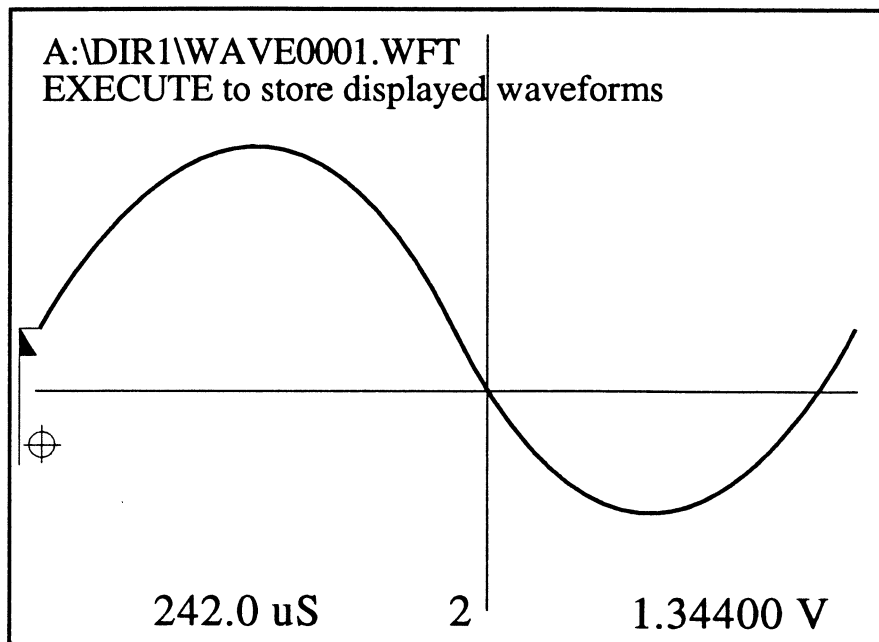

Figure 2 - Sample pathname showing file "WAVE0001.WFT" will be stored on a floppy diskette in internal drive "A" under the root directory "DIR1".

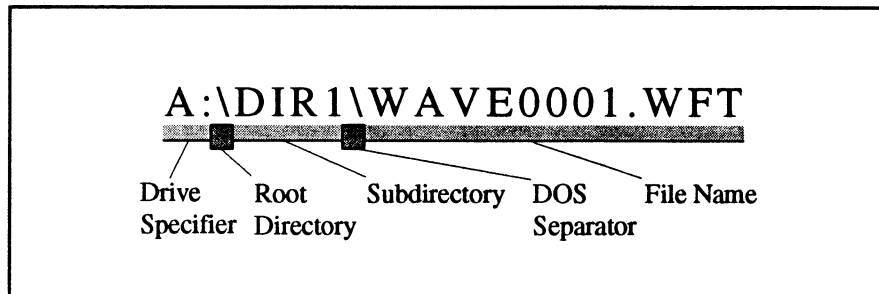

Figure 3 - Pathname Definitions

The Drive Specifier

The Drive Specifier (Figure 3) identifies the various drive storage locations listed below.

Important: You must be in the ROOT directory to access a different drive.

- A: Internal 3.5" floppy drive
- B: First external floppy drive
- C: Fixed hard disk
- D: Bernoulli cartridge/Removable optical disk
- E: Future (not used)
- F: Second external floppy drive

To select a different drive, press the Cursor buttons until the desired Drive Specifier appears (Figure 3).

Note: Only those storage configurations installed on your instrument will appear for selection on the screen. For example, if your instrument is only configured with the internal 3.5" floppy drive and a fixed hard disk, then only drives A: or C: can be selected to store/recall data.

THE DISKETTE FORMAT

The 3-1/2" diskette is a 720 kilobyte (or 1.44 megabyte) formatted, double-sided, high density, soft sector diskette (see Figure 1).

The 5-1/4" diskette is a 1.2 megabyte formatted, double-sided, high density, soft sector diskette.

The diskettes can be formatted in either the internal drive or external Pro Disk drive using the resident Format Disk function accessed via the Menu button (see *Chapter 20*, Format Disk).

Note: You can also format the diskettes on a PC for use with your instrument.

All disks are formatted with the standard MS DOS file structure.

The MS DOS format was chosen for this instrument so that data records can be easily transferred to MS DOS compatible devices (such as IBM PC's and IBM PC Compatibles) for data analysis.

Reading Diskettes in an IBM-PC

Sample programs to read diskettes in an IBM-PC have been supplied with your instrument.

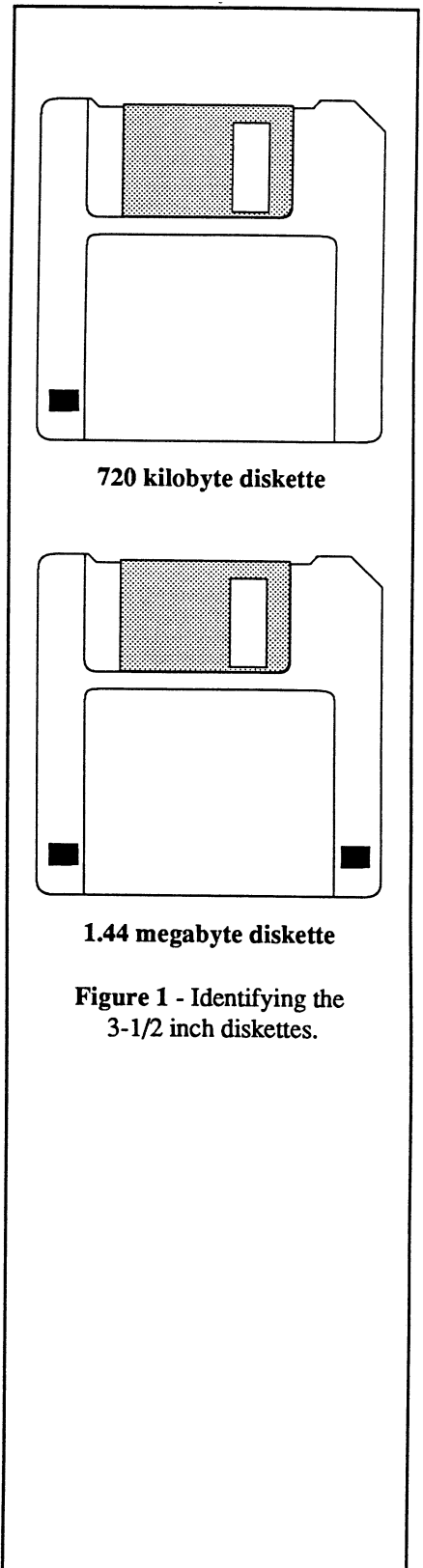

DRIVES, DIRECTORIES AND WAVEFORM FILES

Your instrument automatically creates root directories and subdirectories when the diskette is formatted (see Figure 1).

Before discussing the actual Store and Recall operations, it will be helpful to discuss the terminology that will be used to describe the various drives, directories and file names.

When a diskette is formatted on your instrument, it is automatically assigned a ROOT directory and five (or twenty) subdirectories (Figure 1). File names can be stored under any of the directories for later recall.

Drives A, B & F		Drives C & D	
ROOT	DIR1	ROOT	DIR1
	DIR2		DIR2
	DIR3		DIR3
	DIR4		DIR4
	DIR5		DIR5
			DIR20

Figure 1: Directories created accordingly for the drives being formatted (see Drive Specifier at right).

The Operation

You will be prompted as to whether data will be either "stored" (Figure 2) or "recalled," depending upon whether Store or Recall was pressed.

The Pathname

Figures 2 and 3 illustrate a sample pathname describing the location in which file WAVE0001.WFT will be stored.

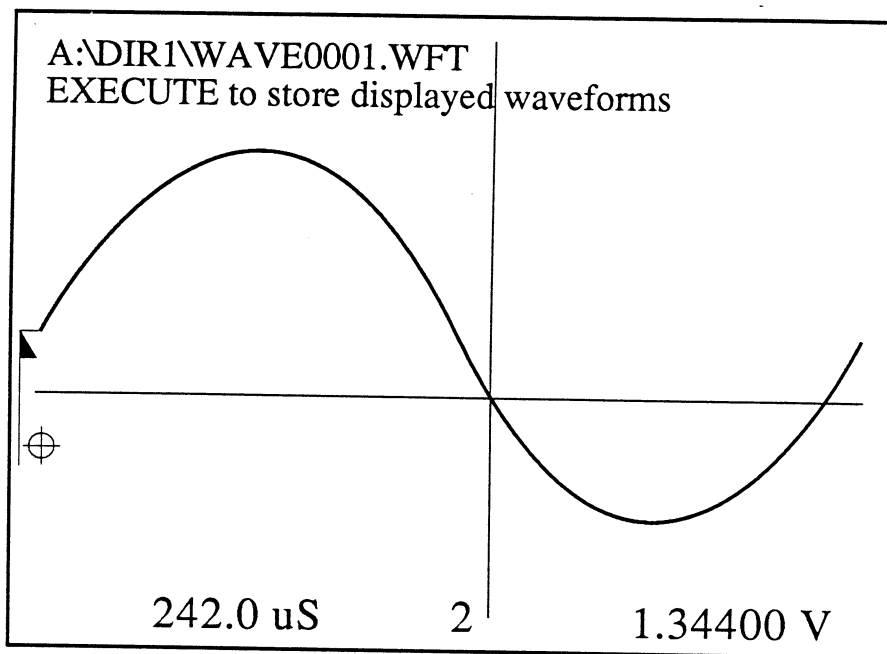

Figure 2 - Sample pathname showing file "WAVE0001.WFT" will be stored on a floppy diskette in internal drive "A" under the root directory "DIR1".

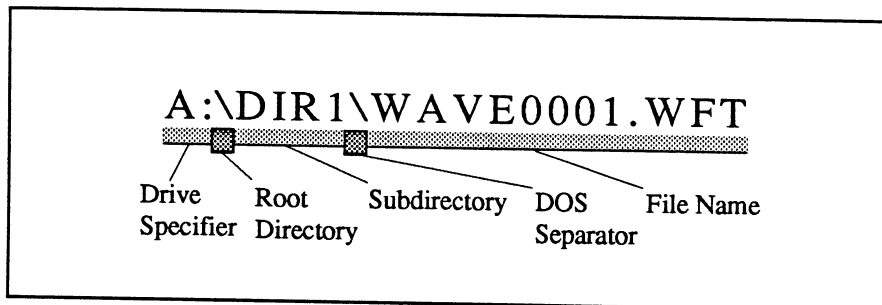

Figure 3 - Pathname Definitions

The Drive Specifier

The Drive Specifier (Figure 3) identifies the various drive storage locations listed below.

Important: You must be in the ROOT directory to access a different drive.

- A: Internal 3.5" floppy drive
- B: First external floppy drive
- C: Fixed hard disk
- D: Bernoulli cartridge
- E: Future (not used)
- F: Second external floppy drive

To select a different drive, press the Cursor buttons until the desired Drive Specifier appears (Figure 3).

Note: Only those storage configurations installed on your instrument will appear for selection on the screen. For example, if your instrument is only configured with the internal 3.5" floppy drive and a fixed hard disk, then only drives A: or C: can be selected to store/recall data.

The Root Directory

The ROOT directory (or home directory) is not labeled. It is identified by the first back-slash (\) in the pathname.

For example, waveform file WAVE0001.WFT in Figure 1 will be stored in the ROOT directory.

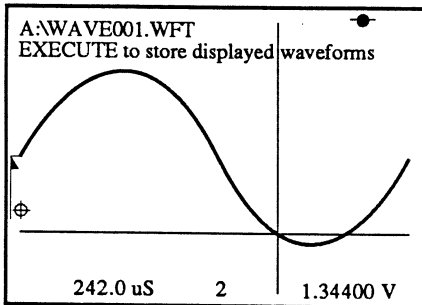

Figure 1 - File WAVE0001.WFT will be stored in the ROOT directory.

Important: The instrument will continue to store (recall) files into (from) the same directory until a different directory is selected.

For example, if you stored the last file in subdirectory DIR2, the next file will also be stored in DIR2 unless a different directory is selected. Each time you press the Store or Recall button, the following prompt will appear on the screen - Store WAVE####.WFT or Recall WAVE####.WFT.

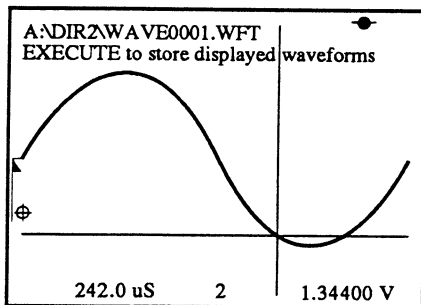

Figure 2 - File WAVE0001.WFT will be stored in subdirectory DIR2

The Subdirectories

Subdirectories DIR1 through DIR5 (or DIR1 through DIR20) can be selected to store the file (Figure 3). Data files can be stored under the root directory or any of the subdirectories.

You must select under which directory a waveform file will be stored, or locate which directory is storing the waveform file you wish to recall.

To select a directory, use the Cursor buttons. The Up/Down cursor buttons move you vertically through the directory paths highlighted on the screen and the Left/Right cursor buttons move you between the root directory and subdirectories (Figure 1).

For example, to reach subdirectory DIR3 in Figure 3 from the root directory, press the Right Cursor button once to reach subdirectory DIR1 and then press the Up Cursor button twice to reach subdirectory DIR3.

The Waveform File Names

Waveform file names are labeled as WAVE####.WFT. Where #### is a number ranging from 0001 to 9999.

To select a waveform file name, press the top or bottom of the Index button until the desired file name appears.

Note: To scroll through the file names, press and hold the bottom or top of the Index button.

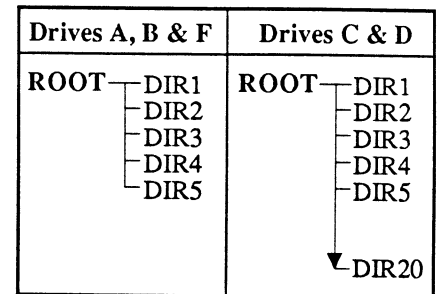

Figure 3: The subdirectories under which data files can be stored. Data files can also be stored directly under the ROOT directory.

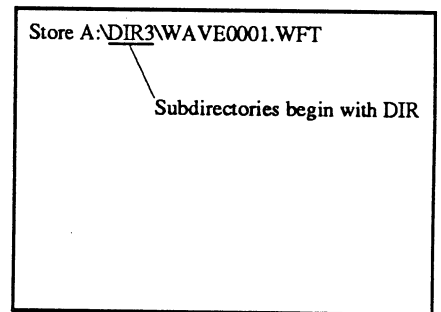

Figure 4 - This example shows that subdirectory DIR3 has been reached.

PROTECTING DATA ON THE DISKETTE

Important: Data may be lost if the diskette is subjected to magnetic fields or any other conditions that may adversely affect the diskette and/or recorded data.

Positioning the protect tab as shown in Figure 1 only allows data to be recalled from the disk. Slide the protect tab downward to erase or replace data already stored on the disk.

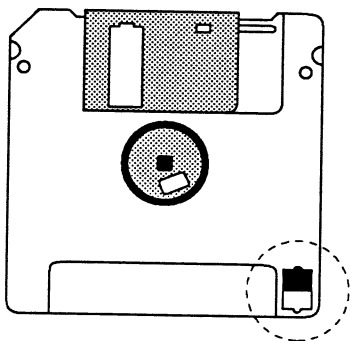

Figure 1: Diskette protected (light can pass through the Protect Tab hole).

LOADING THE DISKETTE

The disk drives automatically energize when power is applied to the instrument. Position the diskettes as shown in Figure 2 and slide the diskette into the drive opening.

To remove the diskette, press the Eject button (Figure 2) and pull the diskette out.

Important: Always load a blank diskette or transport diskette into the drive when transporting the instrument. Damage to the drive heads may occur due to vibrations, etc.

FORMATTING NEW DISKETTES

New, unformatted diskettes must be formatted on the instrument using the FORMAT DISK function accessed via the Menu button.

Refer to *Chapter 21*, FORMAT DISK.

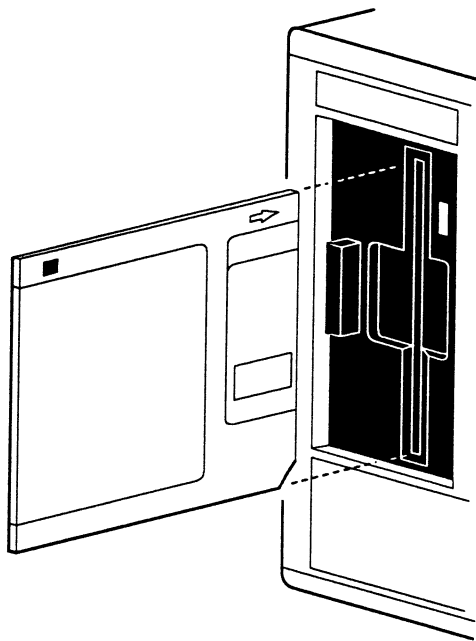

Figure 2: Loading the diskette

STORING WAVEFORMS

Waveforms captured by the instrument can be stored on diskette for later recall.

Note: Waveforms stored in the Sweep Review Memory (see *Chapter 8* in this manual) can also be selected for storage on diskette. Display the desired waveform from the Sweep Review Memory before executing the Store Mode.

There are two methods of storing waveforms:

- a. **Automatically** at the end of each sweep by using the AUTOCYCLE TO DISK Function accessed by the Menu button (see *Chapter 17*, Autocycle To Disk).
- b. **Manually** by pressing the Store button. This method is described here in the following pages.

Initiating the Store Mode

Press the Store button to initiate the Store Mode.

Note: Pressing the Store button while a sweep is in progress automatically aborts the sweep and places the instrument immediately into the Hold Mode (Hold Last LED on, Live LED off).

Aborting the Store Mode

The Store Mode can be aborted at any time (before the Execute button is pressed) by pressing the Store button again. This will return the instrument to the normal waveform display.

Maintaining an Organized Listing

Files are recalled in the same sequence as you store the waveform file names.

For example, if you store the following files in this sequence, WAVE0004.WFT, WAVE0010.WFT, ◀ WAVE0005.WFT, WAVE0006.WFT, then you will see them listed in the same sequence when you search for a file name to be recalled.

If you delete a file name, the deleted file name will be replaced with the next file name you store to the drive. **Please remember, the instrument stores the next waveform file in the first open slot available to store a file.**

For example, if you deleted WAVE0010.WFT in the above example and then stored two new waveform files labeled WAVE0036.WFT and WAVE00040.WFT, you would see the following list; WAVE0004.WFT, WAVE0036.WFT, ◀ WAVE0005.WFT, WAVE0006.WFT, WAVE0040.WFT. ◀

Therefore, it is recommended that you try to label each new waveform file name in a numerical sequence. This will help you locate the desired waveform file name faster when you wish to recall data later for inspection.

For example,
 WAVE0004.WFT
 WAVE0005.WFT
 WAVE0010.WFT
 WAVE0039.WFT

} ascending order
↓

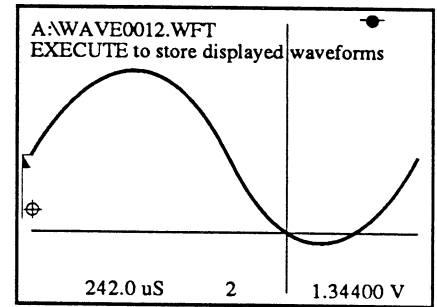

Figure 1 - This waveform will be stored in file WAVE0012.WFT if the Execute button is pressed.

The Default File

The instrument increments one file name automatically for each successive store operation.

For example, if WAVE0003.WFT was used to store the previous waveform, then file WAVE0004.WFT will be automatically selected to store the next waveform (see Figure 1).

Bypassing a Default File

To bypass a default file, press the top or bottom of the Index button until the desired file name appears and then press Execute.

Note: If a default file is bypassed because you do not want to overwrite the existing file, the waveform will be stored in the newly selected file (e.g., WAVE0014.WFT was bypassed to select WAVE0015.WFT). Each additional waveform will then be stored in sequential files, beginning with the newly selected file (e.g., after storing data in WAVE0015.WFT, the next two waveforms will be stored in WAVE0016.WFT and WAVE0017.WFT).

Overwriting an Existing File

If the selected file already contains waveform data and you press the Execute button, the system will alert you that the file already exists (Figure 2). To overwrite the existing file, press the Execute button a second time.

CAUTION: Overwriting an existing file with new data will destroy all data previously stored under that file name.

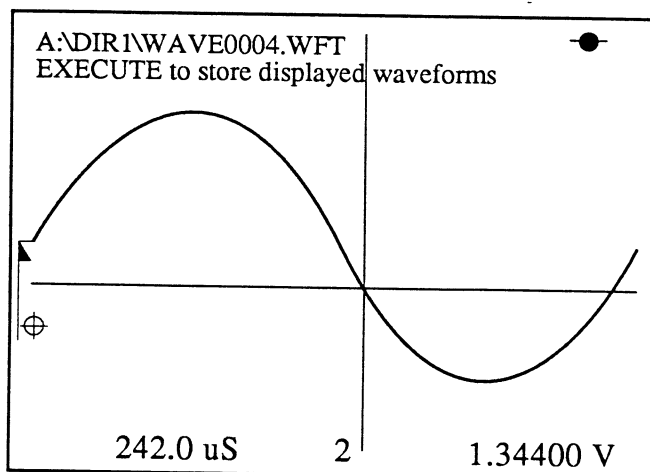

Figure 1 - File WAVE0003.WFT was used to store the last waveform, a new waveform was captured and then the Store button was pressed. This caused the instrument to automatically default to file WAVE0004.WFT as illustrated above.

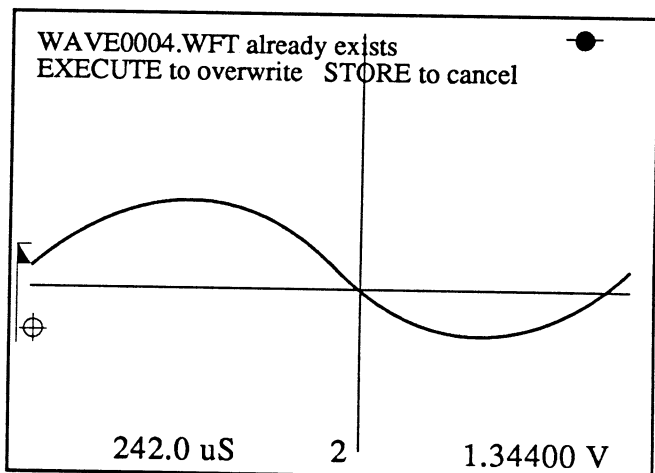

Figure 2 - This illustrates that an attempt was made to store waveform data in a file already containing data. Either bypass the file, overwrite the file with new data, or cancel the Store Mode.

Single Waveform Displays

If only one waveform is displayed on the screen when the Store Mode is executed, the instrument will store that waveform and then return to the normal waveform display.

Multiple Waveform Displays

The waveform identified by the Channel Identifier is always the first waveform that will be stored when the Execute button is pressed. To select a different starting waveform, press the Select button until the desired channel designation appears in the Channel Identifier.

After the first waveform is stored, the instrument (in a predetermined sequence) will select the next waveform and automatically store it in the next default file (unless that file already exists). This sequence continues until the last waveform displayed on the screen is stored.

Figure 1 illustrates that eight waveforms are currently being displayed on the screen and waveform 3 was selected as the first waveform to be stored. Therefore, the sequence will be: 3, 4, 1S, 2S, 3S, 4S, 1, 2.

Figure 2 illustrates that only three waveforms (captured by channels 3, 4 and 3S) are displayed. Once again, the waveform captured by channel 3 was selected to be stored first.

Figures 3 through 5 further illustrate the sequence in Figure 2 as it would be viewed on the screen.

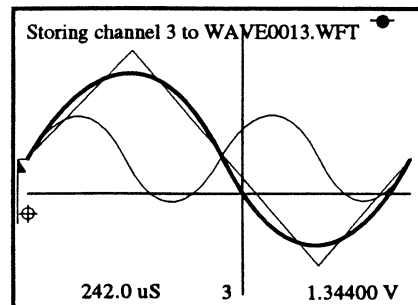
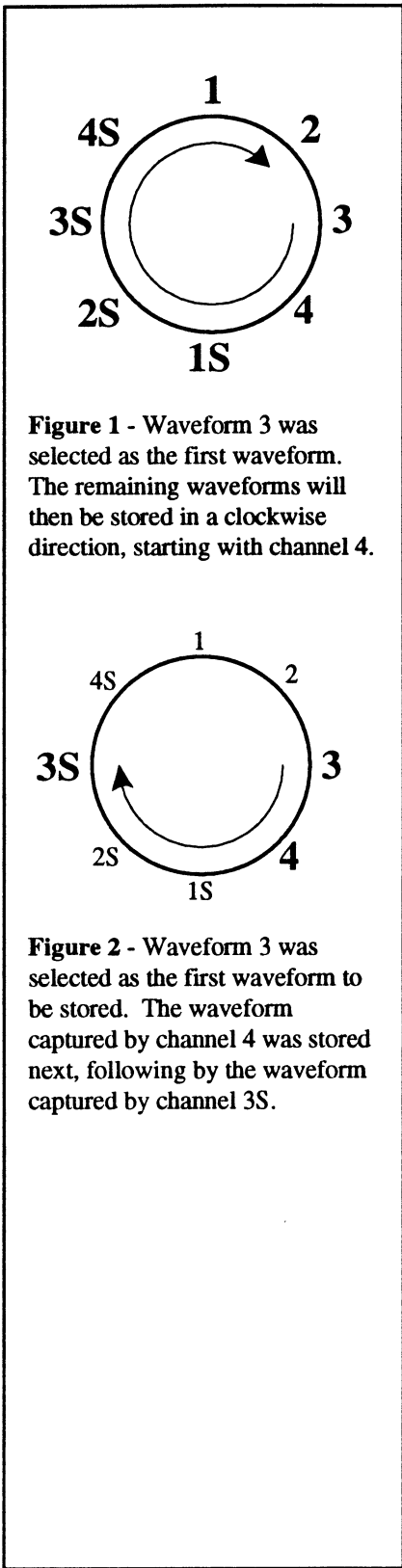

Figure 3 - The first waveform "3" is stored in file WAVE0013.WFT.

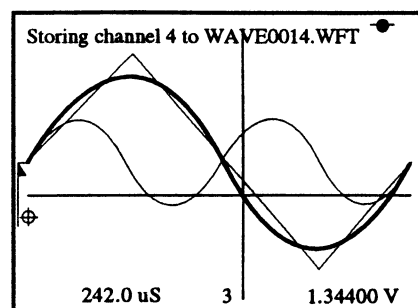

Figure 4 - The second waveform "4" is stored in file WAVE0014.WFT.

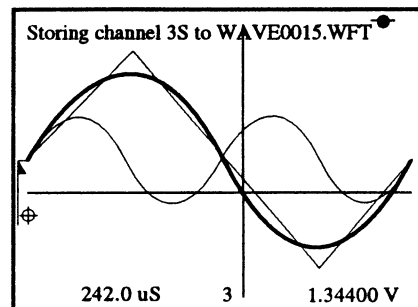

Figure 5 - The third waveform "3S" is stored in file WAVE0015.WFT.

The Store Procedure

1. Insert a formatted diskette into the internal disk drive.
2. If only one waveform is displayed on the screen, continue with step 3.

If multiple waveforms are displayed, press the Select button until the waveform designation you want to be stored first appears in the Channel Identifier. The selected waveform will also appear brighter on the screen.

3. Press the Store button. The default file appears in the upper left corner of the screen.
4. If you want to change the default file, press the top or bottom of the Index button until the desired file name appears.
5. Use the Cursor buttons to select which drive is to store the data (see Table 1).
6. If you want to store the file under a different directory, use the Cursor buttons to make your selection (Figure 1).

7. Press the Execute button to store the waveform. The instrument automatically stores the waveform(s) on diskette.

Note: You will be alerted if the selected file already exists. Perform one of the following three procedures:

- a. Press the Index button to select a different file and then depress Execute.
- b. Press the Execute button to overwrite the file with new data.
- c. Press the Store button to cancel the Store Mode.

- A: Internal 3.5" floppy drive
- B: First external floppy drive
- C: Fixed hard disk
- D: Bernoulli cartridge/Removable optical disk
- E: Future (not used)
- F: Second external floppy drive

Table 1 - Drive Designations

Drives A, B & F	Drives C & D
ROOT — DIR1 — DIR2 — DIR3 — DIR4 — DIR5	ROOT — DIR1 — DIR2 — DIR3 — DIR4 — DIR5 — DIR20

Figure 1: Directories that can be selected to store the waveform files.

THE PRO DISK

The Pro Disk option is functionally identical to the internal disk drive described on the preceding pages.

WARNING: Inspect the voltage selectors at the rear of the Pro Disk and Pro Series oscilloscope for correct settings before applying power. See Chapter 5.

Important: If you are unable to select a drive other than drive "A," the Pro Disk must be initialized. See Chapter 20, INITIALIZE MSO function.

Figure 1 illustrates how to interface the Pro Disk and Pro Series. When configured as shown in Figure 1, the Power On/Off button on the front of the Pro Disk will control power to both units.

When using the Pro Disk with the oscilloscope, you will have to specify on which drive you wish to store a waveform file or from which drive a waveform file will be recalled.

Table 1 lists the drive designations for each of the possible drive configurations.

- A: Internal 3.5" floppy drive
- B: First external floppy drive
- C: Fixed hard disk
- D: Bernoulli cartridge/Removable optical disk
- E: Future (not used)
- F: Second external floppy drive

Table 1 - Drive Designations

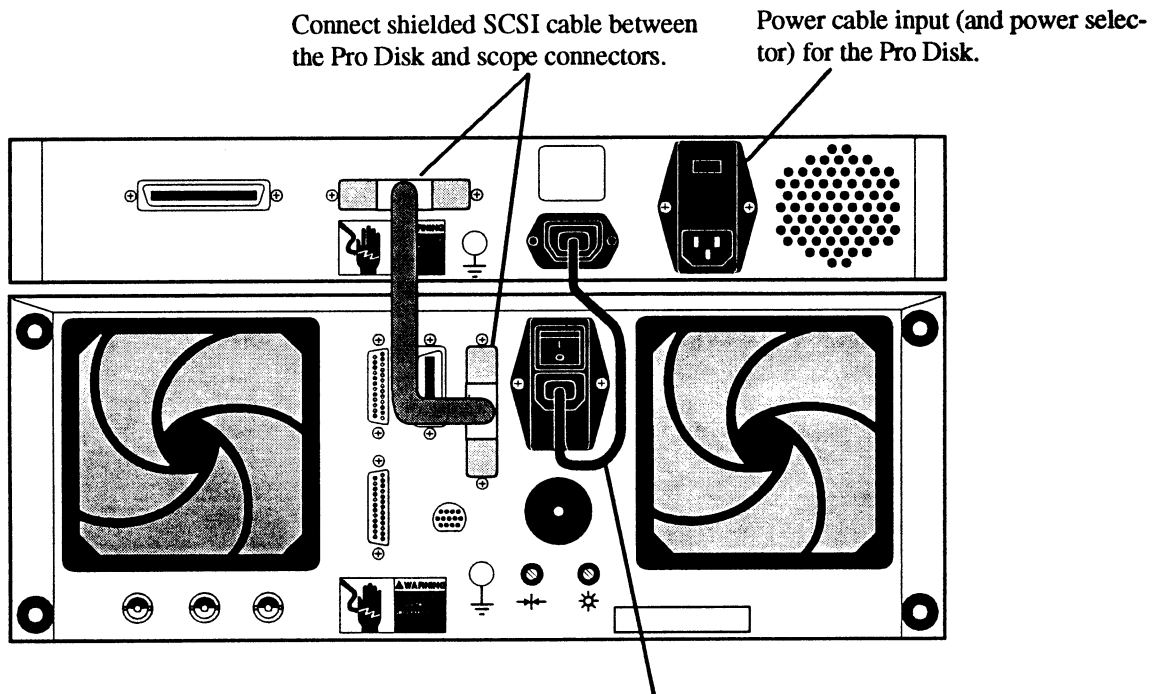

Connecting the power cable as shown above allows the Power On/Off switch on the front panel of the Pro Disk to control power to both units. Leave the scope's power switch in the ON position when using this configuration.

Figure 1 - Interfacing the Pro Disk and the Pro Series

THE FLOPPY DISK

Loading the Diskette

Raise the Lock/Release handle, orientate the diskette as shown in Figure 1 and then slide it into the disk drive opening. When the diskette is properly loaded, lower the Lock/Release handle.

Unloading the Diskette

Raise the Lock/Release handle to release the diskette and then pull the diskette out from the disk drive opening.

The Disk Read/Write LED

The Read/Write LED illuminates when the drive is performing a read/write task.

THE FIXED HARD DISK

The 40 or 80 Megabyte fixed hard disk parks its heads automatically when power is removed from the Pro Disk. However, you should still handle the instrument with care when transporting it to a different location.

An activity LED (Figure 2) illuminates when the fixed hard disk is performing a read/write task.

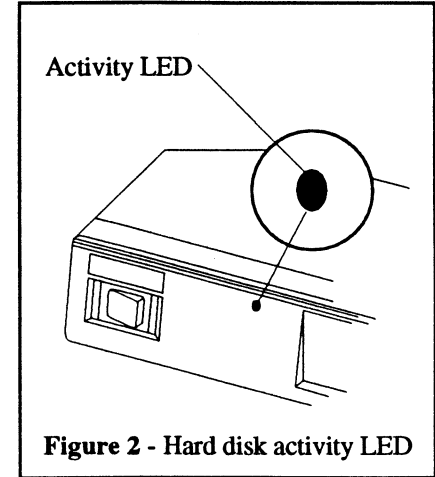

Figure 2 - Hard disk activity LED

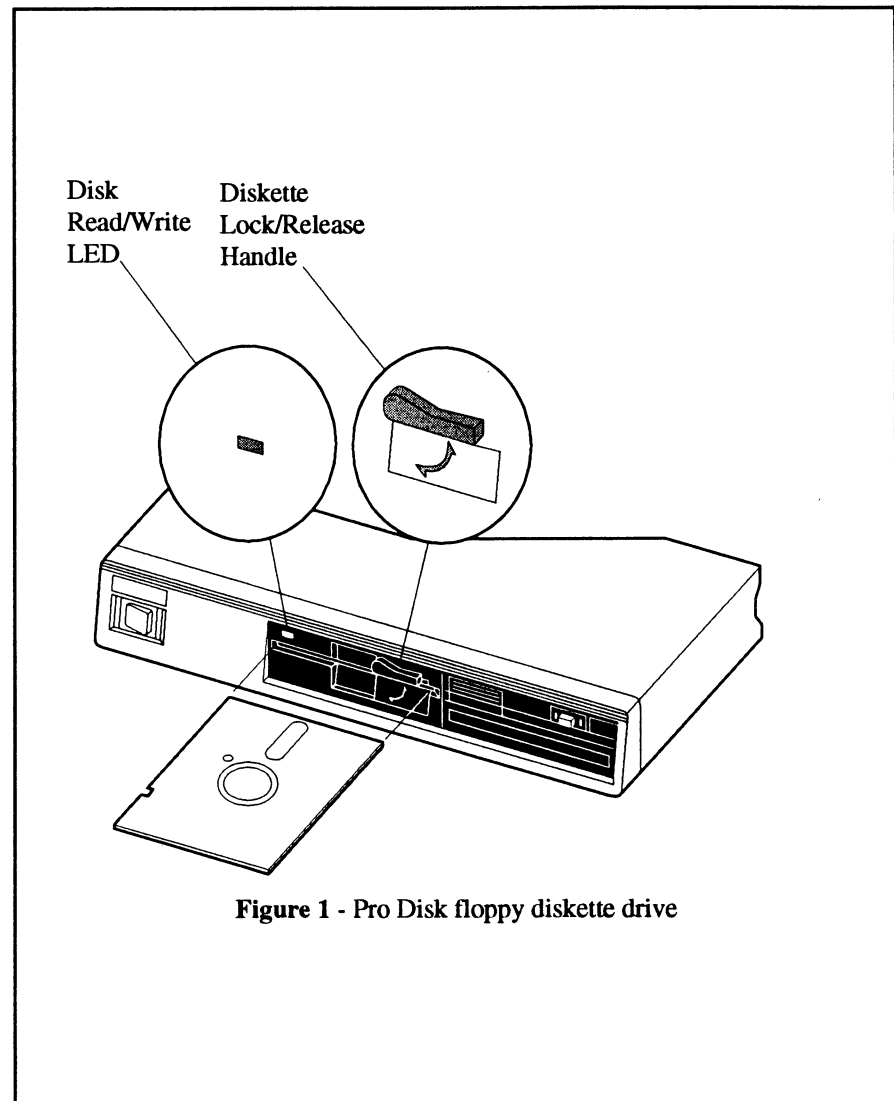

Figure 1 - Pro Disk floppy diskette drive

THE BERNOULLI CARTRIDGE

If the Bernoulli Cartridge drive is not used for several minutes, it automatically turns off to extend the life of the cartridge. The drive is delayed by a few seconds to allow its motor to start the next time it is called upon for use.

Loading the Cartridge

Important: Power must be applied to load the cartridge.

Orientate the cartridge as shown in Figure 1 and slide it into the disk drive opening. The Cartridge Load/Unload LED will flash several times and then remain illuminated if the cartridge has been properly seated into the drive.

Unloading the Cartridge

Important: Power must be applied to unload the cartridge.

Press the Eject Button to eject the diskette and then wait until the Cartridge Load/Unload Indicator stops flashing before pulling out the cartridge.

Cartridge Load/Unload LED

The Bernoulli Cartridge Load/Unload LED will flash several times after you load the cartridge. A steady Green light means it is ready for use.

It also flashes several times when the Eject button is pressed before removing the cartridge. The cartridge cannot be removed until the Load/Unload LED finishes flashing.

Cartridge Read/Write LED

The Cartridge Read/Write Indicator illuminates when the drive is operating on a read/write task.

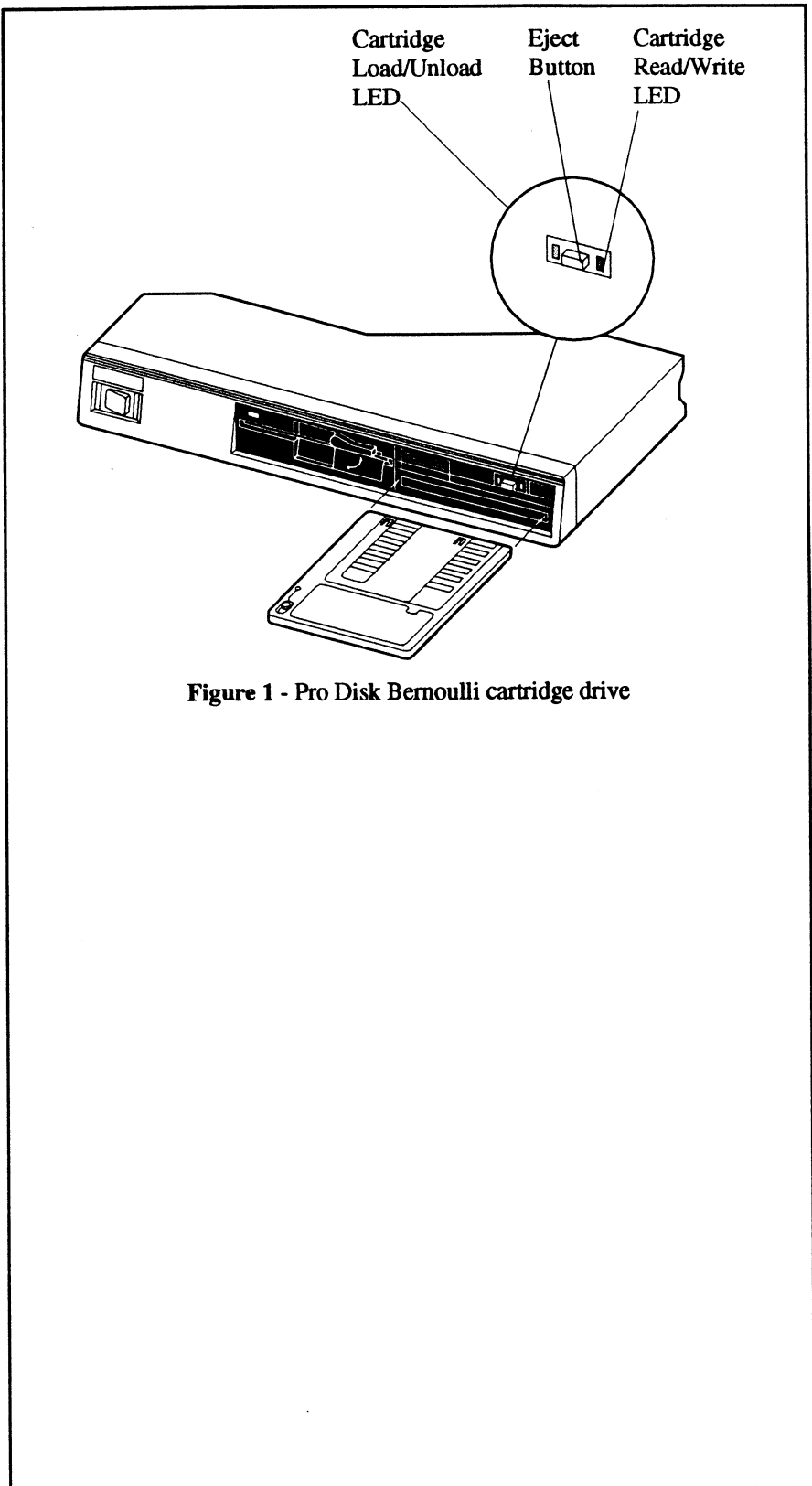

Figure 1 - Pro Disk Bernoulli cartridge drive

THE OPTICAL DRIVE CARTRIDGE

Loading the Cartridge

Important: Power must be applied to load the cartridge.

Orientate the cartridge as shown in Figure 1 and slide it into the drive opening. The Cartridge Status LED illuminates and then turns off when the cartridge is ready.

Unloading the Cartridge

Important: Power must be applied to unload the cartridge by pressing the Eject button. If power is lost and you need to eject a cartridge, insert a straightened paper clip into the Eject Hole.



CAUTION

Only use the Eject Hole procedure if power is lost to the drive.

Press the Eject Button to eject the cartridge. The cartridge will eject part way out of the drive when the Status LED turns off.

Cartridge Status LED

The Cartridge Status LED lights when you load the cartridge and then turns off when it is ready. It also lights when the Eject button is pressed.

The Status LED also lights during seek and read/write operations. Also, it alerts you of dust buildup by flashing on and off.

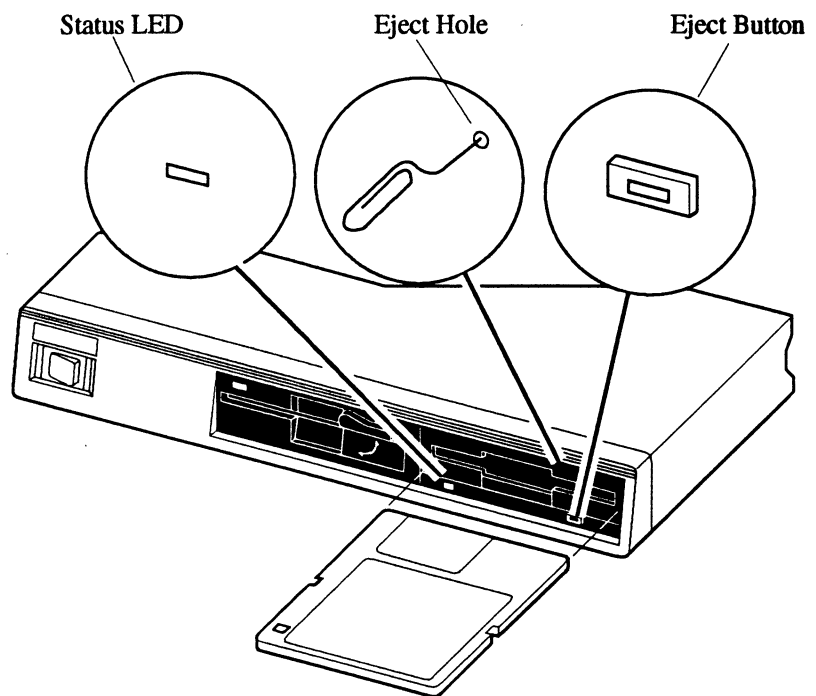

Figure 1 - Pro Disk Optical cartridge drive



WARNING

The Optical Cartridge Drive contains a semiconductor LASER (Light Amplitude Stimulated Emission of Radiation) unit.

DO NOT SERVICE THIS DRIVE UNLESS YOU ARE PROPERLY TRAINED TO SERVICE LASER EQUIPMENT. FOLLOW ALL THE SAFETY RULES SET BY YOUR PLACE OF EMPLOYMENT.

MOUNTING THE PRO DISK TO THE PRO SERIES

1. Remove the two front, bottom feet from the Pro Disk (see Figure 1).
2. Unscrew the top, left side mounting foot from the scope (Figure 2). Store it in a safe place for future use.
3. Using a pliers, carefully unscrew the black plastic insert from the top, right side of the scope while pulling on the insert (Figure 2). Store it in a safe place for future use.
4. Attach the Hold Down Brackets to the Pro Disk using the bottom feet and securing screws removed in step 1 (Figure 3).
5. Mount the Pro Disk to the scope by securing the Hold Down Brackets to the threaded inserts at the top front of the scope's outer cover (Figure 3). Use the #6-32x3/8 screws provided.

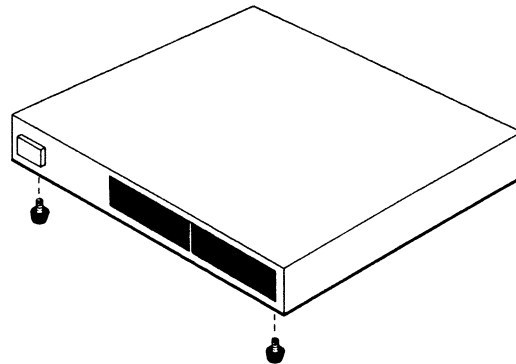

Figure 1 - Remove the Pro Disk's bottom mounting feet.

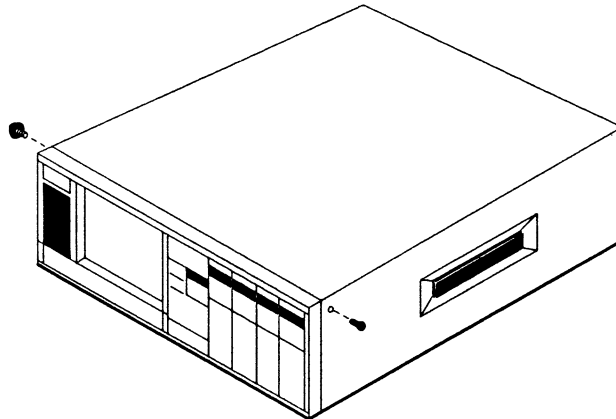

Figure 2 - Remove the scope's mounting foot and plastic insert.

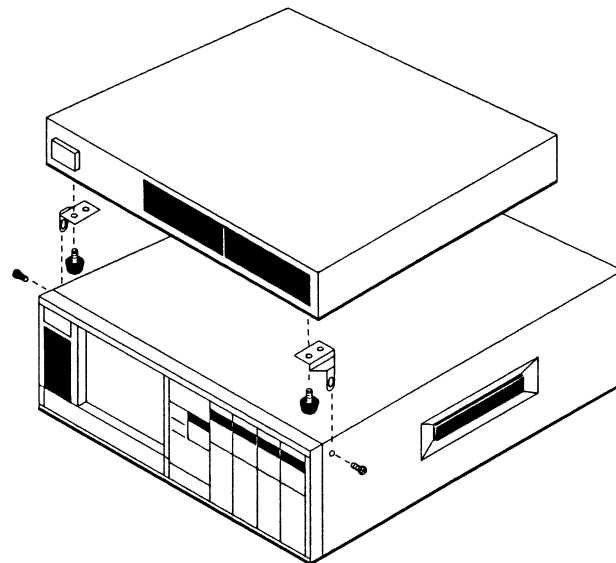

Figure 3 - Mount the hold down brackets to the Pro Disk and then secure the assembly to the scope.

Chapter 24

PLOTTING

WAVEFORMS

Plotter Requirements	24-1
RS232 Plotter Interface	24-3
Setting Up the Plotter	24-3
Interfacing the Scope	24-3
IEEE-488 Plotter Interface	24-4
Setting Up the Plotter	24-4
Interfacing the Scope	24-4
Aborting a Plot	24-4
Executing a Plot	24-5
The Change Plot Parameters Screen	24-6
The Digital Plot Options Screen	24-7
Plotting To Disk	24-8
Point Labeling Waveforms	24-9
Selecting Point Labels	24-9
Executing the Point Label Plot	24-9

Digital Plot Features

- Plots waveforms as viewed on the screen.
- Multiple waveforms can be plotted, or individual waveforms can be selected to be plotted.
- Point labeling allows you to select specific points of interest on the waveform(s) and label the corresponding time and voltage values on the plot.
- Waveforms can be plotted with either solid or dashed line types using up to eight different pens.
- Waveforms can be plotted without a border and scaling values to decrease the plot time.
- Waveforms can be plotted with or without a grid.
- Data output can be via either the RS232, IEEE-488, or PARALLEL ports at the rear of the scope.
- You can quickly plot waveform data to disk for plotting at a later, more convenient time.

Plotter Requirements

Plotter must use HP-GL™ (Hewlett-Packard Graphics Language).

The RS232 Plot Routine uses hardware handshaking. A special cable is provided if the plotter is purchased through Nicolet.

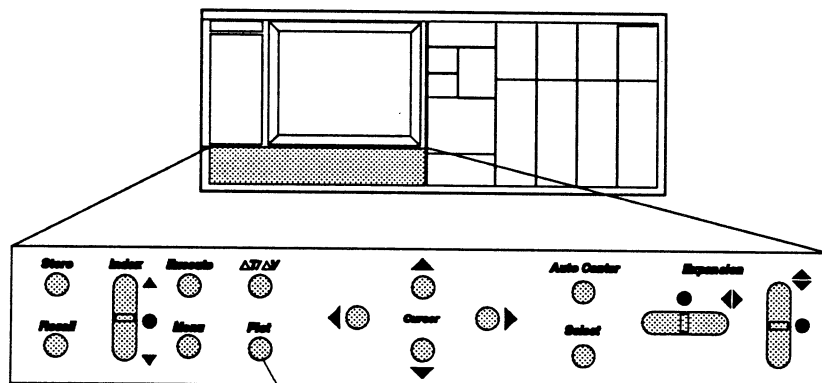

24-5

RS232 PLOTTER INTERFACE

Refer to your plotter manual to set up the plotter with the following parameters.

Setting Up the Plotter

1. 9600 BAUD (or bits per second).

Note: Any available baud rate may be selected, but the plotter baud rate must MATCH the scope's plotter output baud rate. To change the plotter's Baud rate, consult your plotter manual. To change the scope's plotter port baud rate, refer to *Chapter 21, I/O Parameters* function description in this manual.

2. ONE stop bit.
3. Parity OFF.
4. XON/XOFF.
5. Connect the Cable supplied with the plotter by Nicolet. Connect the end labeled SCOPE to the RS-232 port at the back of the scope. Connect the end labelled PLOTTER to the RS232 port on the plotter. If you do not have this cable, it will be necessary to order one or to build your own cable as shown in Figure 1.

Interfacing the Scope

6. To check/set the following parameters refer to I/O Parameters in *Chapter 21*. Check that the scope's factory preset output baud rate is still set for -
 - a. one stop bit
 - b. parity off
 - c. 9600 Baud (or if a different plotter baud rate was selected in step 1, match the plotter's baud rate).
7. Press the Plot button. The Digital Plot Options screen appears.
8. Using the Up/Down Cursor buttons, move the option pointer to the Change Plot Parameters field and then press the Execute button. The Change Plot Parameters screen appears.
9. If RS232 is not displayed in the Port Used field, use the Up/Down Cursor buttons to select the Port Used field and press either the Left or Right Cursor button. RS232 should appear in the Port Used field. Press the Execute button to return to the Digital Plot Options screen.
10. Continue with Executing a Plot, *page 24-5*.

Scope Port Pins	Plotter Port Pins	Function
2 _____	3 _____	Plotter Transmit, Scope Receive Scope Transmit, Plotter Receive Ground
3 _____	2 _____	
7 _____	7 _____	

Figure 1

IEEE-488 PLOTTER INTERFACE

Refer to your plotter manual to set up the plotter with the following parameters:

Setting Up the Plotter

1. Set the plotter's IEEE-488 (GPIB) address to GPIB Address 5. This is the factory default address for Hewlett Packard plotters.
2. Connect a GPIB cable between the scope's IEEE-488 port and the plotter.

Interfacing the Scope

3. Press the Plot button. The Digital Plot Options screen appears.
4. Using the Up/Down Cursor buttons, move the option pointer to the Change Plot Parameters field and then press the Execute button. The Change Plot Parameters screen appears.
5. If IEEE488 is not displayed in the Port Used field, use the Up/Down Cursor buttons to select the Port Used field and press either the Left or Right Cursor button. IEEE488 should appear in the Port Used field. Press the Execute button to return to the Digital Plot Options screen.
6. Go on to Executing a Plot on the next page.

THE PARALLEL CONNECTOR

The Parallel connector is used to output data to an EPSON (or compatible) dot-matrix printer.

Setting Up the Plotter

Refer to your dot-matrix printer manual for operating instructions.

1. Connect the cable between the scope's PARALLEL port and the dot-matrix printer.

Interfacing the Scope

1. Press the Plot button. The Digital Plot Options screen appears.
2. Using the Up/Down Cursor buttons, move the option pointer to the Change Plot Parameters field and then press the Execute button. The Change Plot Parameters screen appears.
3. If PARALLEL is not displayed in the Port Used field, use the Up/Down Cursor buttons to select the Port Used field and press either the Left or Right Cursor button. PARALLEL should appear in the Port Used field. Press the Execute button to return to the Digital Plot Options screen.
4. Go on to Executing a Plot on the next page.

ABORTING A PLOT

Press the Plot button to abort a plot already in progress.

Note: The plotter may continue to run for a short period of time depending on the amount of data remaining in the buffer memory when the Plot button is pressed.

EXECUTING A PLOT

1. Capture and display the desired signal or signals that are to be plotted.
2. Press the Hold Last button and wait for the sweep to end.

Note: Pressing the Plot button while in Live automatically places the scope into the Hold Mode (Hold Last LED on, Live LED off). A sweep in progress will be aborted.

3. Press the Plot button. The Digital Plot Options screen appears (Figure 1).
4. Using the Up/Down cursor buttons, move the option pointer until the Change Plot Parameters field is selected and then press the Execute button. The Change Plot Parameters screen appears (see Figure 2).
5. Make any changes desired on the Change Plot Parameters screen (see page 24-6) and then press the Execute button to return to the Digital Plot Options screen.

Note: If you have set the PORT USED field to 'FILE,' perform step 6a. If you set the field to RS232, IEEE488, or PARALLEL, perform step 6b.
- 6a. Select the type of plot to be output to the plotter and then press the Execute button. Execute the Plot From Disk function, *chapter 20*.
- 6b. Select the type of plot to be output to the plotter (see page 24-7) and then press the Execute button to output the data to the plotter.

DIGITAL PLOT OPTIONS

ALL WAVES ON SCREEN
(includes scaling values)

ALL WAVES WITH POINT LABELS
(includes scaling values)

SELECTED WAVE ONLY
(without scaling values)

SELECTED WAVE WITH POINT LABELS
(without scaling values)

BORDER ONLY

► CHANGE PLOT PARAMETERS

▲/▼ changes option pointer
EXECUTE starts selected option

(Push PLOT to exit)

Figure 1 - Digital Plot Options Screen

CHANGE PLOT PARAMETERS

PLOTTER TYPE	HPGL
PORT USED	RS232
GRID ON PAPER	NO
LINE TYPES	SOLID
NUMBER OF PENS	8

▲/▼ moves to next field
◀/▶ changes current field
EXECUTE returns to plot menu
(Push PLOT to exit)

Figure 2 - Change Plot Parameters Screen

THE CHANGE PLOT PARAMETERS SCREEN

Use the Up/Down Cursor buttons to move the selection box and the Left/Right Cursor buttons to change the parameter. When all selections have been made, press the Plot button to return to the Digital Plot Options screen.

Plotter Type

Select accordingly for the type of plotter/printer you will be using.

HPGL: Standard HPGL plotter.

PCL5: Laser printer which supports HPGL commands (e.g., HP LaserJet 3 or HP LaserJet 4 printer).

Port Used

Select either **RS232**, **IEEE488**, **PARALLEL**, or **FILE** accordingly for the output port being used to interface your scope and plotter.

Note: **FILE** is used with the PLOT FROM DISK function, *Chapter 20*.

Grid On Paper

Select **NO** for plots without a grid, **YES** for plots with a grid.

Line Types

Select **SOLID** if all waveforms are to be plotted with a solid line. Select **DASHED** to plot each waveform with a unique dashed line type to help differentiate between multiple waveform plots (Figure 2).

Note: The first waveform will be plotted with a solid line type.

Number Of Pens

Up to eight different colored pens can be used to plot a multiple waveforms display. Enter a number equal to the number of pens loaded on the plotter.

Note: The border and numbers are drawn with pen #1, the first waveform uses pen #2, the second uses pen #3, etc.

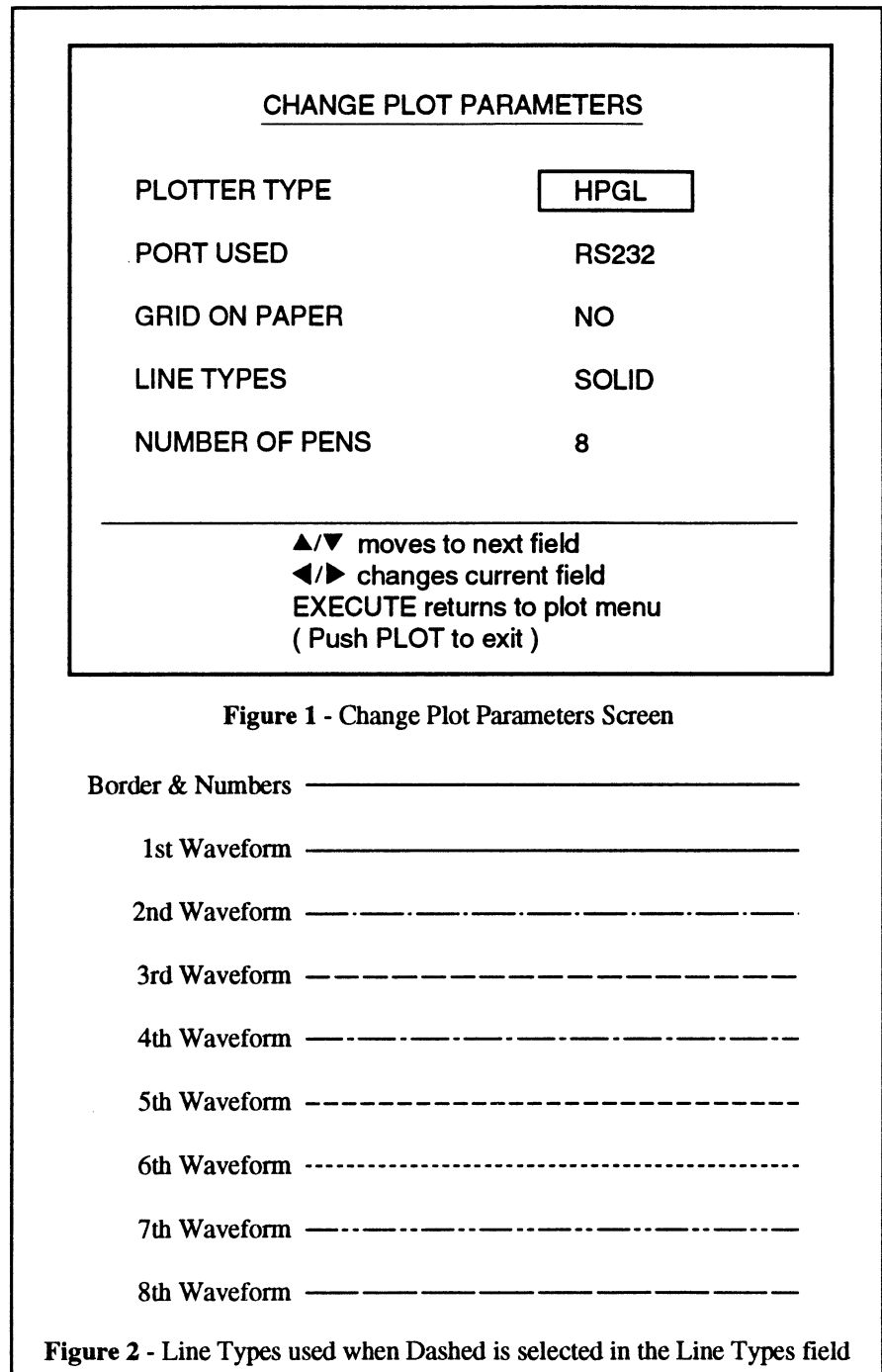

THE DIGITAL PLOT OPTIONS SCREEN

Use the Up/Down Cursor buttons to move the pointer. When all selections have been made (including any changes on the Change Plot Parameters screen, press the Execute button.

Note: If the PORT USED field (page 24-6) was set to RS232, IEEE488 or PARALLEL, data is output to the plotter. If it was set to 'FILE,' the Plot To Disk display appears, see the next page.

All Waves On Screen

Executing this option will output all of the waveforms displayed on the screen. The axis' scaling values will be also be plotted.

All Waves With Point Labels

Executing this option allows you to select specific points of interest on the displayed waveforms which will be labeled on the plot. The axis' scaling values will be also be plotted.

Selected Wave Only

Execute this option to plot only the selected waveform when multiple waveforms are displayed. This option will not include the border or any axis' scaling values to decrease the plotting time.

To select a specific waveform, press the Select button until the desired waveform brightens on the screen (the Channel Identifier identifies which channel captured the waveform).

Note: If a border is desired, execute the Border Only option either before or after plotting the selected waveform.

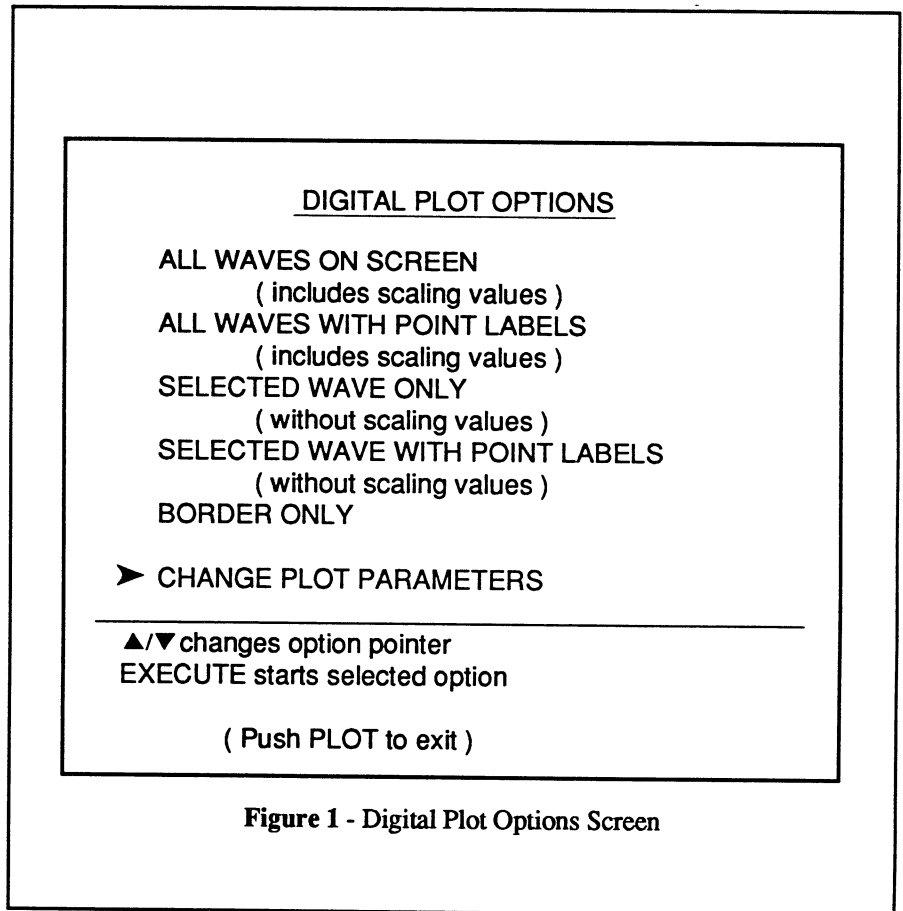

Figure 1 - Digital Plot Options Screen

Selected Wave With Point Labels

Execute this option to plot only the selected waveform along with selected points of interest labeled on the plot. This option does not include the border or any axis' scaling values to decrease the plotting time.

To select a specific waveform, press the Select button until the desired waveform brightens on the screen (the Channel Identifier identifies which channel captured the waveform).

Note: If a border is desired, execute the Border Only option either before or after plotting the selected waveform.

Border Only

Execute this option to plot the border and axis' without any waveforms. This option is used when a border is desired when plotting waveforms using the SELECT WAVE ONLY or SELECTED WAVE WITH POINT LABELS options.

Change Plot Parameters

Execute this option to select -

- a. the I/O port,
- b. whether the waveforms will be plotted with a grid,
- c. whether multiple waveforms will be plotted with unique dashed line types, and
- d. the number of pens (maximum of eight) that will be used to plot the waveforms.

PLOTTING TO DISK

There may be times when you do not wish to interrupt acquisitions to output data to a plotter. The Plot To Disk display (Figure 1) allows you to quickly store the data to the disk which then can be plotted at your convenience using the Plot From Disk function (see *chapter 20*).

1. After executing any of the first five options on the Digital Plot Options screen (see preceding page), the Plot To Disk screen appears.

Note: The Select button is used to determine whether the cursor buttons will change the "drive/path" or the "file number." If necessary, press the Select button until "CURSORS change drive/path" appears towards the bottom of the screen.

2. To change the drive/path, press the Select button and then use the Cursor buttons to select the drive/path.
 - A = Internal 3.5" floppy drive
 - B = First external floppy drive
 - C = Fixed hard disk
 - D = Bernoulli cartridge
 - E = Future (not used)
 - F = Second external floppy drive
3. When the desired drive/path has been selected, press the Select button and then use the Up/Down Cursor buttons to select the file name under which you wish to store the plot file.
4. Press the Execute button to store the plot file.

When you wish to output the plot file to a plotter, execute Plot From Disk (see *chapter 20*).

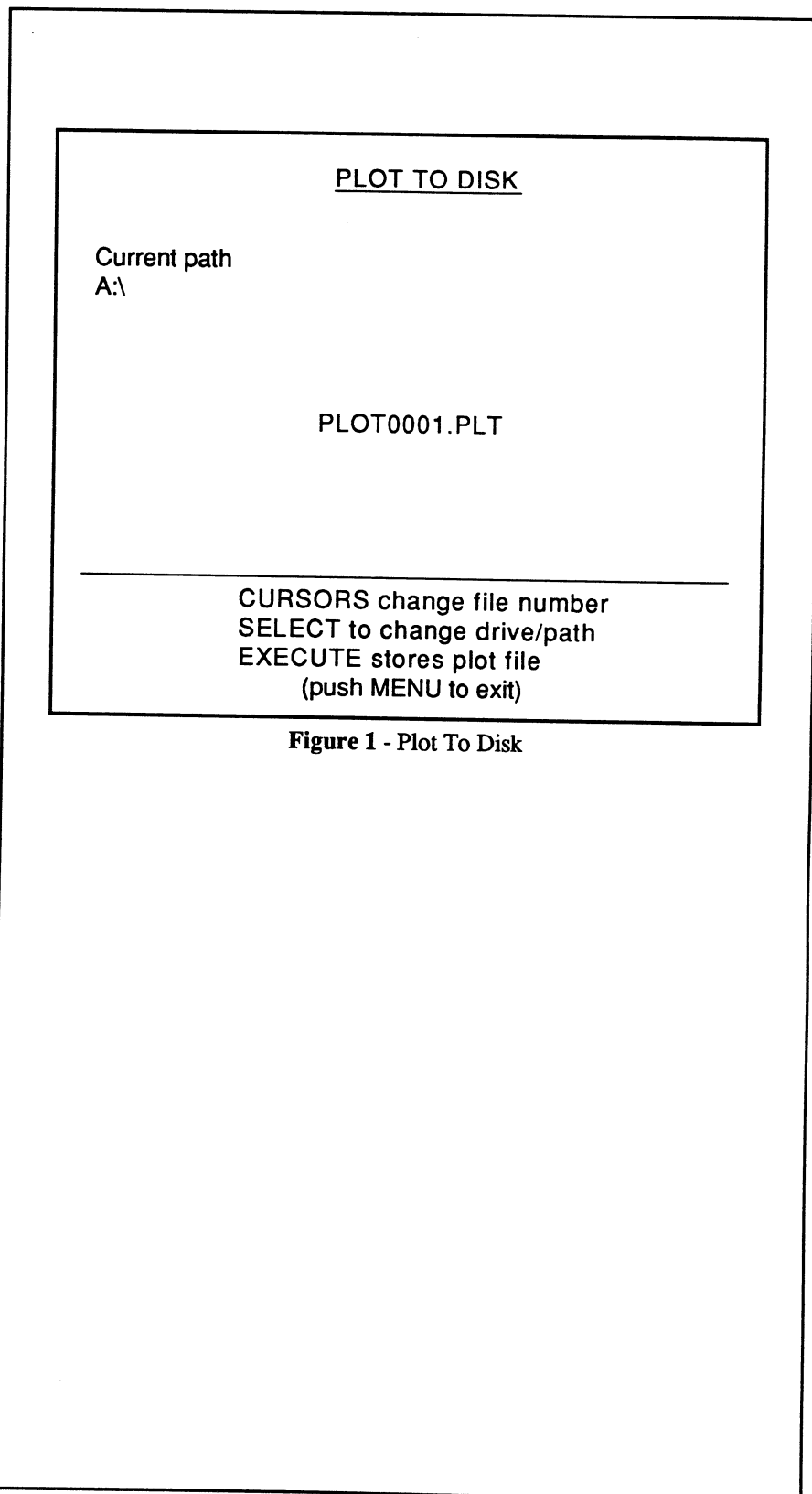

Figure 1 - Plot To Disk

POINT LABELING WAVEFORMS

The ALL WAVES WITH POINT LABELS and SELECTED WAVE WITH POINT LABELS allow you to select specific points of interest on the waveform(s) which will then be identified on the plot along with the point's time and voltage values (see Figure 1).

Executing either of the Point Label options will return the waveform display (Figure 1).

Selecting Point Labels

1. Move the vertical cursor (or crosshair if Autocenter is turned on) over the point of interest by pressing the Left or Right Cursor buttons.

2. Press the Execute button. The selected point will now be labeled on the plot.

Repeat the above two steps until all of the desired points of interest have been selected (use the Select button to move to a different waveform if desired).

Executing a Point Label Plot

Pressing the Execute button twice without moving the vertical cursor (or crosshair) will cause the scope to plot the waveforms.

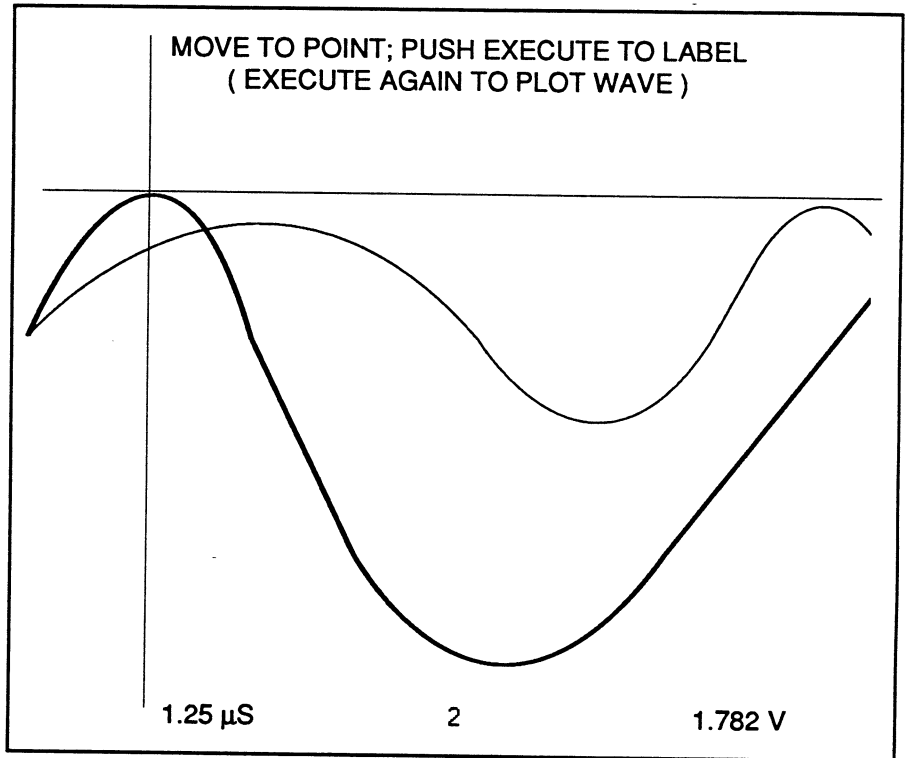

Figure 1 - Point Label waveform display with the crosshair positioned over the point of interest that is to be labeled on the plot.

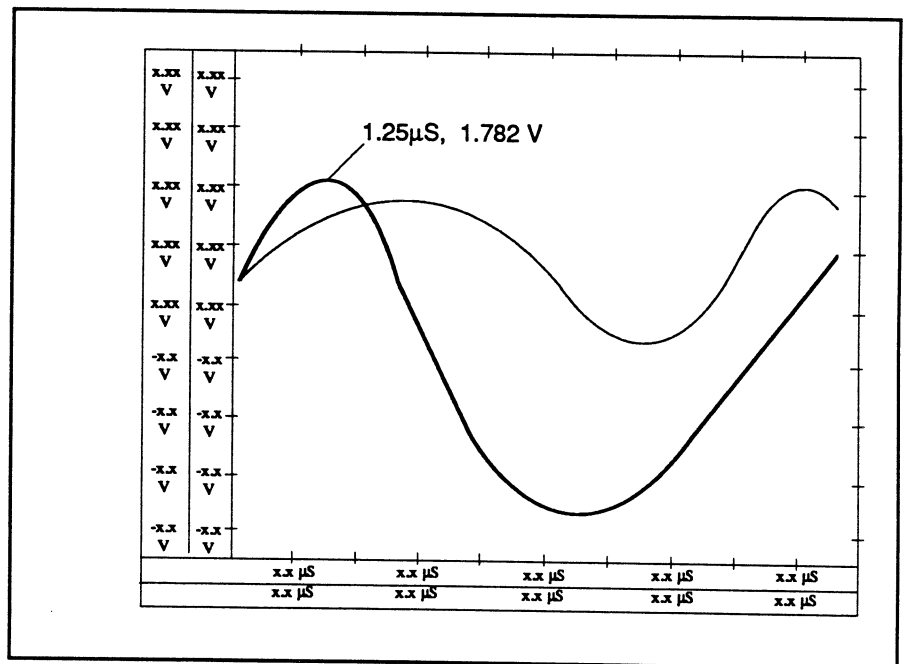

Figure 2 - The point of interest selected in Figure 1 is labeled on the plot with its time and voltage values.

Chapter 25

THE REAR PANEL

CONTROLS

Rear Panel Control Summaries	25-3
The RS-232 Connector	25-4
The IEEE-488 (GPIB) Connector	25-5
Recommended Cables	25-6

This chapter describes the instrument's rear panel controls and recommended cabling.

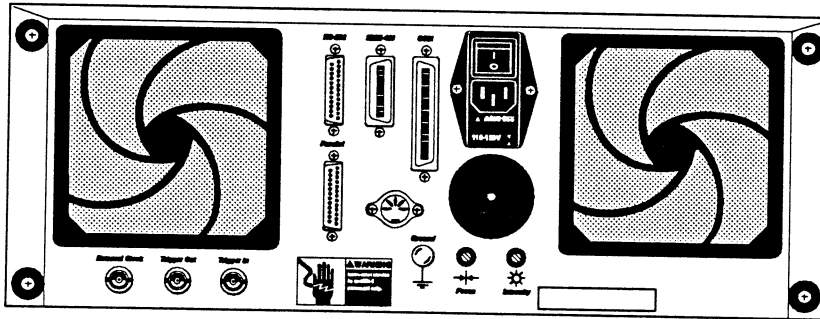

Figure 1 - Rear Panel

REAR PANEL CONTROLS SUMMARIES

Output connector for EPSON compatible dot-matrix printer

RS-232 Connector
See page 25-4

IEEE-488 (GPIB) Connector. See page 25-5

SCSI connector for the optional Pro Disk mass storage option (MSO)

Power switch, voltage selector and fuse holder

CAUTION: See Chapter 5 before applying power to the instrument.

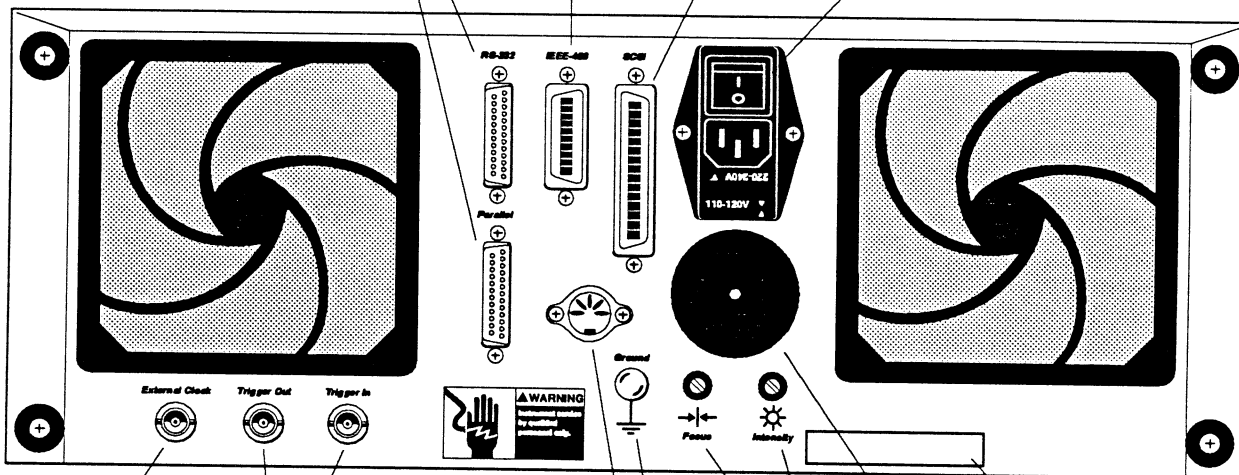

External clock input BNC for nonperiodic or nonstandard time-per-point sampling

Master/slave input/output BNC's

Optional Keyboard Port

Grounding Lug

Focus and Intensity controls

Backup Battery. See Chapter 5

Serial Number

CAUTION: To ensure adequate ventilation, do not block the rear panel fans or operate the instrument while it is standing upright on its rear panel.

RS-232 CONNECTOR

The RS-232 parameters are set by the resident I/O Parameters function. See *Chapter 21, I/O Parameters*.

Physical Limitations

1. The maximum transmission distance is unlimited if telephone lines are used. Direct cable linkups are limited to 50 feet.
2. The maximum data transfer rate is determined by the allowable baud rates (bits per second) of the communicating devices. The instrument can run at 300, 600, 1200, 2400, 4800, 9600, 19,200 baud.

RS-232 Pin Explanations

Following are explanations of the RS-232 pins as they relate to your instrument.

Note: Pins not described are not supported by the instrument.

1. **Protective ground**
2. **TDATA:** Transmitted Data Path for outgoing data.
3. **RDATA:** Received Data Path for incoming data.
4. **RTS:** Request To Send Activated by the sending device to tell the sending modem to get ready for data transmission.

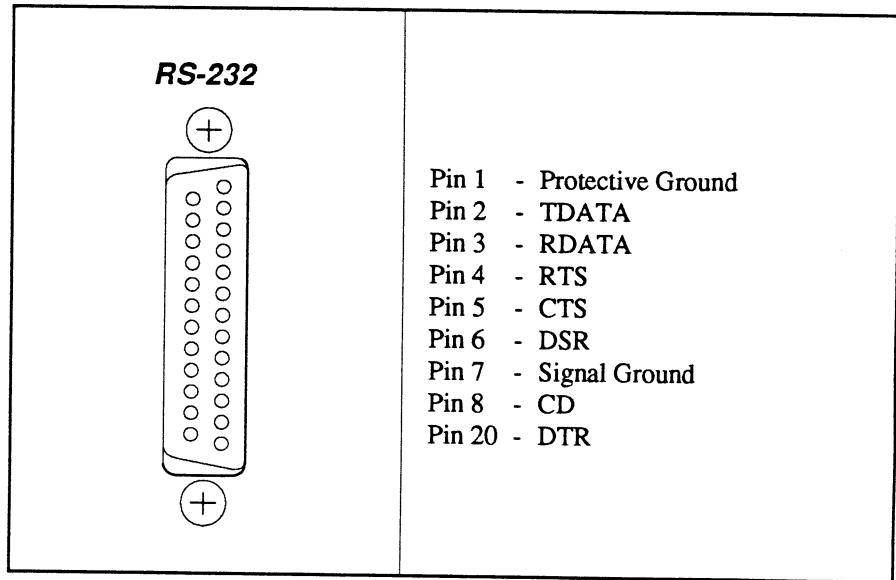

Figure 1

Voltage	Status (for Handshaking Lines)	Binary (for Data)
- 3 volts to -25 volts	Off	1
+3 volts to +25 volts	ON	0

Table 1

5. **CTS:** Clear To Send Activated by the receiving modem to tell the sending device that it is ready for transmissions. The instrument will pause during data transmission if this line is turned off (-10V). Data transmissions from the instrument will resume as soon as this line is turned on (+10V). No characters will be lost.
6. **DSR:** Data Set Ready. A data set is a modem. This line is activated by the sending modem to tell the receiving device that it is ready for a Request To Send.
7. **Signal Ground**
8. **CD:** Carrier Detected Activated by the receiving modem to tell the receiving device that a carrier signal has been detected and data will soon follow.
20. **DTR:** Data Terminal Ready Activated by the sending device to tell the sending modem that it is ready to transmit data.

IEEE-488 (GPIB) CONNECTOR

The IEEE-488 parameters are set by the resident I/O Parameters function. See *Chapter 21*, I/O Parameters.

Physical Limitations

1. Maximum of 15 devices on one GPIB.
2. Maximum of 2 meters of cable between any two devices or 20 meters of cable in total, whichever is less.
3. The maximum data transfer rates are determined by the slowest device involved in the data transfer. Computer program execution speed is an important factor in data transfer rates.

IEEE-488 (GPIB) Pin Explanations

Following are explanations of the IEEE-488 (GPIB) as they relate to your instrument.

Note: "1" is represented by a low voltage (approximately 0V). "0" is represented by a high voltage (approximately 3V).

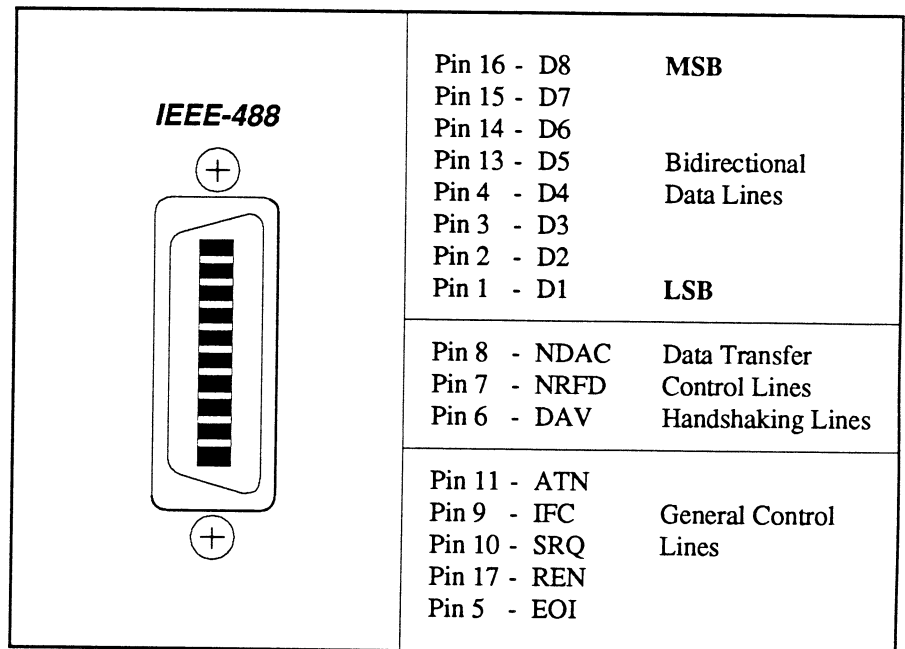

Figure 1

D1 through D8: Carry data into or out of the instrument. Carry addresses into the instrument. Carry specialized controller commands into the instrument.

NDAC: Not Data Accepted
1 = Ready to accept data.

NRFD: Not Ready For Data
1 = Not OK to send data.

DAV: Data Valid
1 = Data valid on data lines

ATN: Attention
0 = Data lines have data.
1 = Data lines have an address or GPIB command.

IFC: Interface Clear

1 = "Clears" all devices attached to the GPIB bus so that they are off the GPIB bus.

SRQ: Service Request

1 = Tells the controlling computer that some device on the GPIB bus has information to be released.

REN: Remote Enable

1 = Enables the interface for GPIB bus control from a remote device.

EOI: End or Identify

1 = Indicates to the device receiving information that the last information to be sent is on the data lines.

RECOMMENDED CABLES

The following cables are currently recommended by Nicolet for use with your instrument.

Note: These recommendations may change without notice.

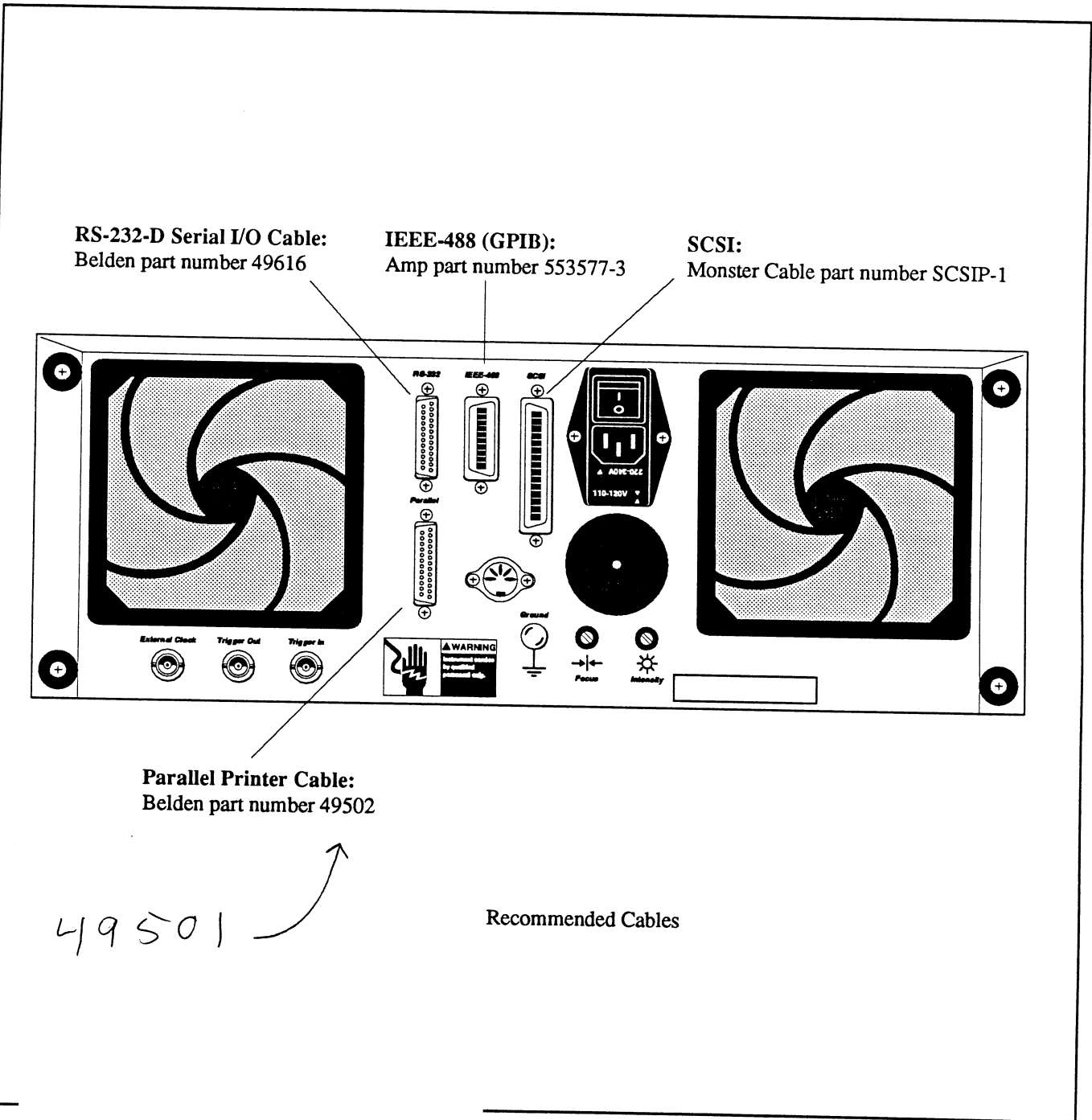

Chapter 26

WAVEFORM FILE SPECIFICATIONS[©]

File Header _____	26-3
Header Data Type _____	26-3
Actual Data _____	26-3
• Normalization Equations	26-3
Time Domain Waveform Data Fields _____	26-4
Frequency Domain Waveform Data Fields _____	26-7

This chapter contains both the Time Domain and Frequency Domain Waveform Data Fields descriptions. It also includes the Normalization Equations.

A **Time Domain** file is identified by a ".WFT" extension, while a **Frequency Domain** file is identified by a ".WFF" extension.

PC Utilities

WFT ~~2~~ FLT

Floating point ASCII file

to

WFT 2 ASC

converts to ASCII w/no normali:

FILE HEADER

The file header size is determined by the value entered in the field "Header_Size." The individual file header fields are fixed in length and are ASCII alphanumeric strings, each terminated by a null (00) byte.

The simplest file, containing a single waveform with a single timebase, will have a header of 1538 bytes. A file containing multiple waveform segments or multiple timebases will expand the header length as needed.

All fields are left justified ASCII character strings, followed by a null byte, followed by spaces if needed to fill the allotted space. If a particular field is not used, its first byte is a null byte.

Since the header contains only ASCII characters and ends with a CONTROL-Z character, the header text can be conveniently viewed on a PC screen by using the MS-DOS "TYPE" command, for example "TYPE WAVE0001.WFT <Return>."

DATA TYPE

"Integer" means an ASCII whole number, for example "2" or "262144." Note that the values are not limited to a 16-bit range: the "Time" field, in milliseconds since midnight, may contain a number as large as 89,400,000.

"Character" means ASCII text, for example "V" or "Test #12."

"Float" means an ASCII number in scientific notation, for example "5.0000000E-6."

ACTUAL DATA

The actual data (raw data) follows immediately after the file header. The data is in binary format. Please note that the data type (number of bytes per point, and byte sex) are described in the file header.

Normally data is in a 16-bit integer range from -32768 to +32767, with the low byte appearing first. *2's complement*

Raw data is converted into time and voltage values by the calculations shown below in Equations 1.

$$\text{Time} = ((\text{point\#} * \text{HORIZONTAL_NORM}) + \text{HORIZONTAL_ZERO}) * \text{USER_HORIZONTAL_NORM} + \text{USER_HORIZONTAL_ZERO}$$

point#	= Represents the n-th point in a sweep.
HORIZONTAL_NORM	= Time per point, in seconds.
HORIZONTAL_ZERO	= Trigger to 1st point, in seconds.
USER_HORIZONTAL_NORM	= User multiplier, unitless (normally 1)
USER_HORIZONTAL_ZERO	= User time offset, in seconds (normally 0)

$$\text{Volts} = ((\text{data} - \text{VERTICAL_ZERO}) * \text{VERTICAL_NORM}) * \text{USER_VERTICAL_NORM} + \text{USER_VERTICAL_ZERO}$$

data	= Raw digitizer data (-32,768 through 32,767)
VERTICAL_ZERO	= Absolute zero reference from the ADC
VERTICAL_NORM	= Voltage per level
USER_VERTICAL_NORM	= User defined multiplier (normally 1)
USER_VERTICAL_ZERO	= User defined offset in volts (normally 0)

Equations 1 - Normalization Equations

TIME DOMAIN WAVEFORM DATA FIELDS

Offset	Max. Size (Bytes)	Field Name	ASCII Data Type	Field Description
0	2	Nic_id0	Integer	CPU type ID (byte sex) 1 = VAX, 2 = 68000, 3 = Intel: normally 3
2	2	Nic_id1	Integer	Nicolet division indicator: always 2
4	2	Nic_id2	Integer	Nicolet file format: 1 = Time domain, 2 = Frequency domain
6	2	User_id	Integer	User ID
8	12	Header_size	Integer	Length of file header in bytes
20	12	File_size	Integer	Length of entire file in bytes
32	12	File format version	Integer	Version of file format
44	81	Waveform title	Character	Waveform title
125	3	Date_year	Integer	Date of trigger of segment #1 - year
128	3	Date_month	Integer	Date of trigger of segment #1 - month
131	3	Date_day	Integer	Date of trigger of segment #1 - day
134	12	Time	Integer	Time of trigger of segment #1 - msec since midnight
146	12	Data_Count	Integer	Total number of data points
158	12	Vertical_zero	Integer	Data value at which the voltage value is 0.00 volts -VREF
170	24	Vertical_norm	Float	Voltage magnitude between levels - VNORM
194	24	User_vertical_zero	Float	User voltage offset
218	24	User_vertical_norm	Float	User units per volt
242	11	User_vertical_label	Char	User vertical label: default = "V"
253	24	User_horizontal_zero	Float	User time offset
277	24	User_horizontal_norm	Float	User seconds per unit
301	11	User_horizontal_label	Character	User horizontal label: default = "S"

Table 1 - Time Domain Data Fields and Descriptions

Continued on the next page.

Offset	Max. Size (Bytes)	Field Name	ASCII Data Type	Field Description
312	129	User_Notes	Character	Note field, additional information
441	196	Audit	Character	Audit array of all calculations
637	21	Nicolet_Digitizer_Type	Character	Nicolet digitizer description
658	3	Bytes_per_data_point	Integer	Amount of bytes to store 1 data point: normally 2
661	3	Resolution	Integer	Number of active bits in a data point
664	81	Forward_link	Character	Pathname/file following in time the current file (Note 1).
745	81	Backward_link	Character	Pathname/file preceding in time the current file (Note 1)
826	3	Process flag	Integer	Process Flag - # of memory altering math functions performed
829	3	Data compression	Integer	Type of data compression used on raw data: 0 = none
832	12	Number of segments	Integer	Number of segments
844	12	Length of each segment	Integer	Length of each segment
856	12	Number of timebases	Integer	Number of timebases per segment
868	156	Reserved N/A	N/A	Reserved for Nicolet internal use only
1024	12	Length of zone 1	Integer	Length in points of zone 1
1036	24	Horiz. norm. zone 1	Float	Time between data points (tpp) - HNORM
1060	24	Horiz. zero zone 1	Float	Time of 1st point in zone 1 with respect to the trigger
1084	12	Length of zone 2	Integer	Length in points of zone 2 (Note 1)
1096	24	Horiz. norm. zone 2	Float	Time between data points (tpp) - HNORM (Note 1)
1120	24	Horiz. zero zone 2	Float	Time of 1st point in zone 2 with respect to the trigger (Note 1)
1144	12	Length of zone 3	Integer	Length in points of zone 3 (Note 1)
1156	24	Horiz. norm. zone 3	Float	Time between data points (tpp) - HNORM (Note 1)
1180	24	Horiz. zero zone 3	Float	Time of 1st point in zone 3 with respect to the trigger (Note 1)
1204	332	Reserved N/A	N/A	Reserved for Nicolet internal use only

Table 1 - Time Domain Data Fields continued

Note 1: Not currently used with your instrument.

Continued on the next page.

Offset	Max. Size (Bytes)	Field Name	ASCII Data Type	Field Description
1536 (Note 2)	24	Segment #2 HDELTA	Float	Time value of 1st point relative to time of 1st point of seg. #1
1560 (Note 2)	24	Segment #3 HDELTA	Float	Time value of 1st point relative to time of 1st point of seg. #1
1584 (Note 2)	24	Segment #4 HDELTA	Float	Time value of 1st point relative to time of 1st point of seg. #1
1608 (Note 2)	24	Segment #5 HDELTA	Float	Time value of 1st point relative to time of 1st point of seg. #1
1632 (Note 2)	24	Segment #6 HDELTA	Float	Time value of 1st point relative to time of 1st point of seg. #1
1656 (Note 2)	24	Segment #7 HDELTA	Float	Time value of 1st point relative to time of 1st point of seg. #1
1680 (Note 2)	24	Segment #8 HDELTA	Float	Time value of 1st point relative to time of 1st point of seg. #1
1704 (Note 2)	24	Segment #9 HDELTA	Float	Time value of 1st point relative to time of 1st point of seg. #1
1536 + (24 * (n-2))	24	Segment #n HDELTA	Float	Time value of 1st point relative to time of 1st point of seg. #1
Header_Size - 2	1	End of HDELTA's	Null	
Header_size - 1	1	End of readable file	Control Z	End of readable data - Raw data follows
Header_size	Data _ Count	Start of raw data	Raw	Binary data: normally 16-bit words in two's compliment arranged in low byte/high byte order
File_size - 1	Data _ Count * Bytes_per_data_point	End of raw data		

Table 1 - Time Domain Data Fields continued

Note 2: These fields are present only in multi-waveform files.

FREQUENCY DOMAIN WAVEFORM DATA FIELDS

Offset	Max. Size (Bytes)	Field Name	ASCII Data Type	Field Description
0	2	Nic_id0	Integer	CPU type ID (byte sex) 1 = VAX, 2 = 68000, 3 = Intel: normally 3
2	2	Nic_id1	Integer	Nicolet division indicator: always 2
4	2	Nic_id2	Integer	Nicolet file format: 1 = Time Domain, 2 = Frequency Domain
6	2	User_id	Integer	User ID
8	12	Header_size	Integer	Length of file header in bytes
20	12	File_size	Integer	Length of entire file in bytes
32	12	File format version	Integer	Version of file format
44	81	Waveform title	Character	Waveform title
125	3	Date_year	Integer	Date of trigger - year
128	3	Date_month	Integer	Date of trigger - month
131	3	Date_day	Integer	Date of trigger - day
134	12	Time	Integer	Time of trigger - msec since midnight
146	12	Data_Count	Integer	Total number of data points
158	12	Real/Mag vertical zero	Integer	Data value at which the voltage value is 0.00 volts
170	24	Real/Mag vertical Norm	Float	Voltage magnitude between levels
194	24	Frequency zero	Float	Frequency value of 1st data point
218	24	Frequency per point	Float	Frequency value between each data point
242	24	User Real/Mag vert. zero	Float	User volts offset Real/Mag
266	24	User Real/Mag vert. norm	Float	User volts per unit Real/Mag
290	11	User Real/Mag label	Character	User vertical label
301	24	User frequency zero	Float	User frequency offset
325	24	User frequency norm	Float	User Hertz per unit

Table 2 - Frequency Domain Data Fields and Descriptions

Continued on the next page.

Offset	Max. Size (Bytes)	Field Name	ASCII Data Type	Field Description
349	11	User horizontal label	Character	User horizontal label
360	129	User notes	Character	Note field, additional information
489	196	Audit	Character	Audit array of all calculations
685	21	Nicolet digitizer type	Character	Nicolet digitizer description
706	3	Bytes per data point	Integer	Amount of bytes to store 1 data point
709	3	Resolution	Integer	Number of active bits in a data point
712	81	Forward link	Character	Pathname/file following in time the current file (Note 1)
793	81	Backward link	Character	Pathname/file preceding in time the current file (Note 1)
874	3	Process flag	Integer	Process Flag - Indicator that raw data has been processed
877	3	Data compression type	Integer	Type of data compression used on raw data: 0 = none
880	12	Imag/Phase vert. zero	Integer	Data value at which the voltage value is 0.00 volts - VREF
892	24	Imag/Phase vert. norm.	Float	Voltage magnitude between levels - VNORM
916	24	User Imag/Phase vert. zero	Float	User voltage offset Imag/Phase
940	24	User Imag/Phase vert. norm	Float	User voltage per unit Imag/Phase
964	11	User Imag/Phase label	Character	User vertical label Image/Phase
975	3	Data creation method code	Integer	Indicator of the type of function used to create the raw data
978	3	Storage representation code	Integer	Indicator of the storage method of the raw data
981	3	Data modification code	Integer	Indicator of the type of modification done on the original data
984	2	Degree/Radian data type	Character	Indicator of the type of normalization - D = deg. R = radians
986	37	Reserved N/A	N/A	Reserved for Nicolet internal use only
1023	1	End of readable file	Control Z	End of readable file data - Raw data immediately follows

Table 2 - Frequency Domain Data Fields continued

Note 1: Not currently used with your instrument.

Chapter 27

OPERATING

THE PRO 90 & 92

PRO 90 & 92 FEATURE ONLY

Using Dual Sample Rates

27-3

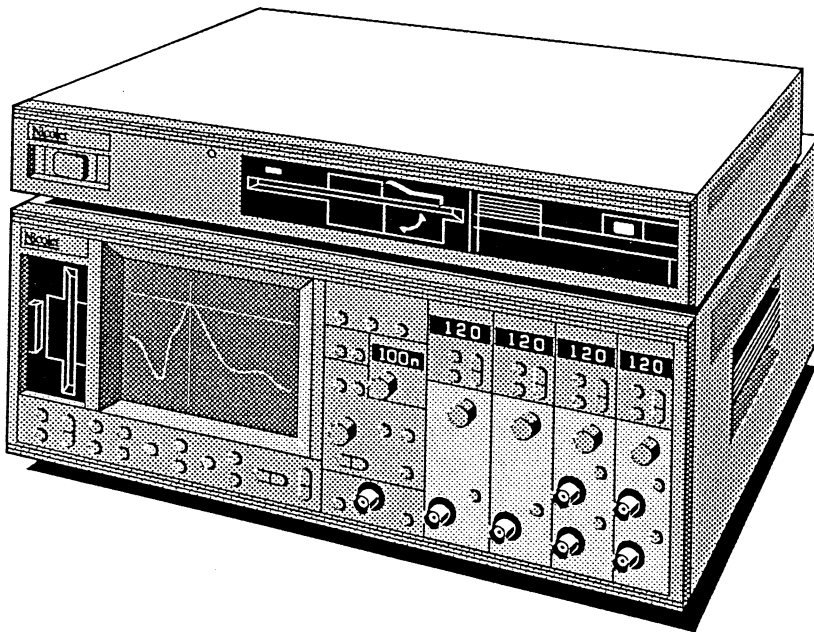

Pro 90 with two 8 bit, 200 mS/s, digitizers and two 12 bit, 10 MS/s digitizers

The four channel Pro 90 and 92 allow you to mix two different digitizers for dual sampling rates so that you can capture data with -

two high speed channels

(Pro 90 = 200 MS/s, 8 bit digitizers)

(Pro 92 = 200 MS/s, 8 bit digitizers)

and two high resolution channels

(Pro 90 = 10 MS/s, 12 bit digitizers)

(Pro 92 = 20 MS/s, 12 bit digitizers)

The basic operation of each channel is identical to that as described in the preceding chapters of this manual. This chapter will describe the Dual Sample Rates feature and any other operating considerations you should be aware of when mixing digitizer types for signal acquisitions.

USING DUAL SAMPLE RATES

The **Dual Sample Rates** function allows the Pro 90 or Pro 92 to simultaneously capture input signals sampled at two different rates. This dual timebase feature allows you to capture and observe both slow and fast events simultaneously.

With the Pro 90, for example, you can simultaneously capture up to two signals with the 8 bit, 200 MS/s digitizer channels and up to two signals with the 12 bit, 10 MS/s digitizer channels. The Pro 92 uses the 8 bit, 200 MS/s and 12 bit, 20 MS/s digitizers.

Note: Channels 1 and 2 always have identical Time Per Point settings. Likewise, channels 3 and 4 always share identical Time Per Point settings. For example, if you set channel 1 to 1.0 μ S, then channel 2 will also be set to 1.0 μ S.

1. Press the Menu button. The Menu screen appears (Figure 1).
2. Using the Cursor buttons, select the ACQUISITION menu and then select DUAL SAMPLE RATES as shown in Figure 1.
3. Press the Execute button. The Dual Sample Rates execution screen appears (Figure 2).
4. Press the Execute button. The waveform display returns.
5. Turn on the channels with which you want to capture input signals. You now can set the Time Per Point for the enabled channels as described on the next page.

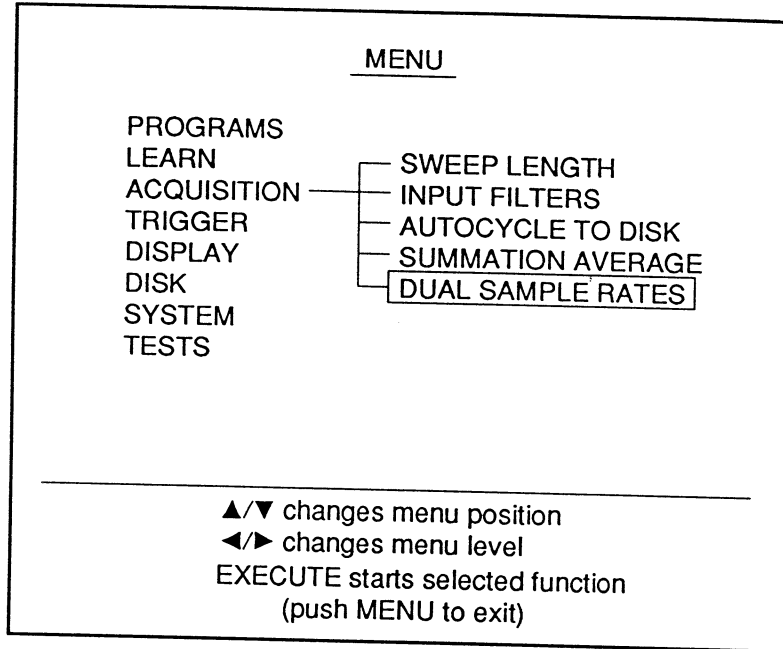

Figure 1 - Dual Sample Rates

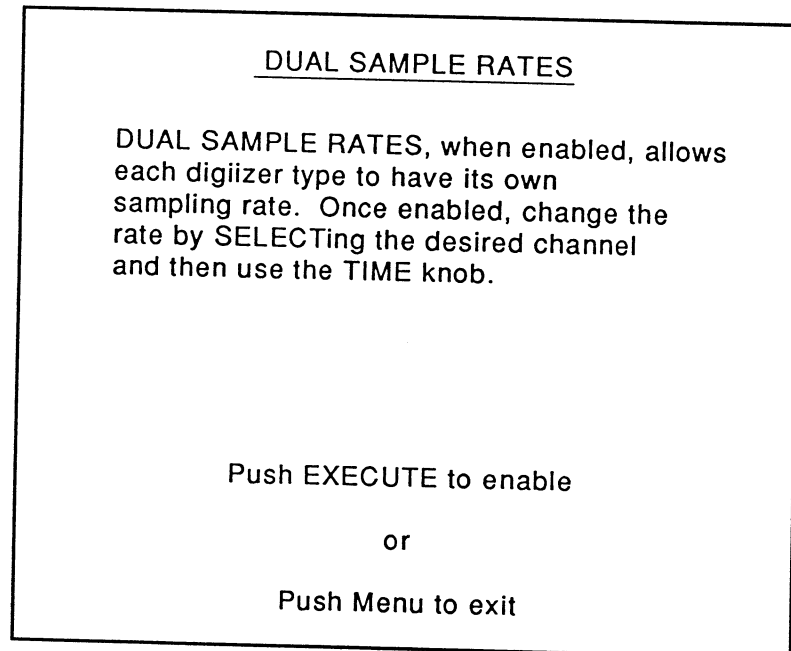

Figure 2 - Dual Sample Rates execution screen

6. To set the Time Per Point value for channels 1 and 2, highlight the left value (Figure 1) by pressing the Select button and then adjusting the Time control knob until the desired setting appears.
7. To set the Time Per Point value for channels 3 and 4, highlight the right value by pressing the Select button and then adjusting the Time control knob.
8. If you are not using External triggering, select the channel with the fastest Time Per Point setting as the trigger source.

For example, if you set channel 1 to 500 nS and channel 3 to 1.0 μ S as shown in Figure 1, select channel 1 as the trigger source.

You can read time and voltage values directly from the numerics in the normal manner by pressing the Select button until the desired waveform is highlighted. The Channel Identifier will identify which channel captured the selected waveform and the Time numerics will decode time values accordingly for the Time Per Point setting that was used to capture the waveform.

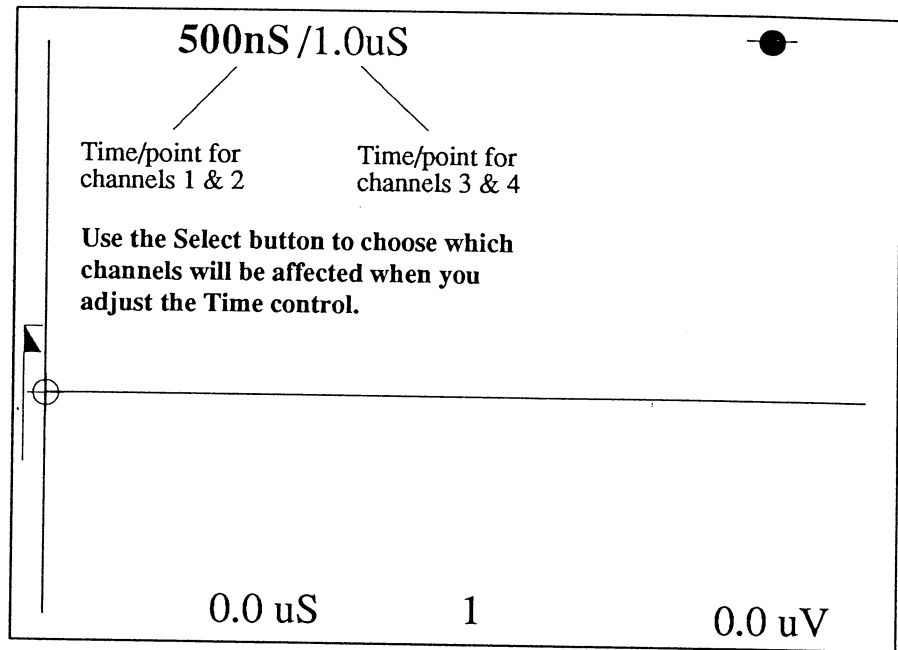

Figure 1 - The Time Per Point has been set to 500 nS for channels 1 and 2, and 1.0 μ S for channels 3 and 4 in this example. The Select button is used to choose which pair of channels will be set by adjusting the Time control.

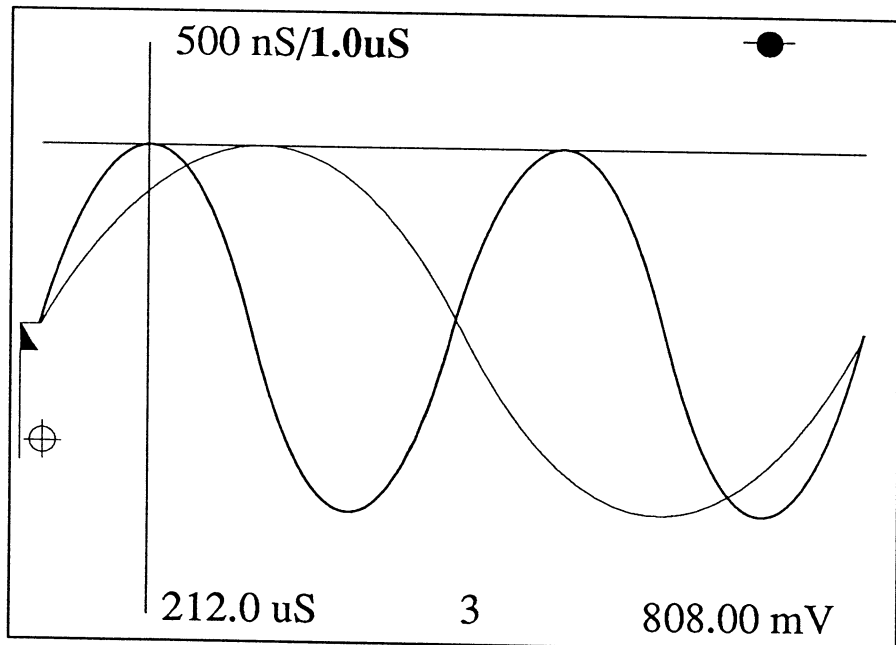

Figure 2 - Two identical signals were input to channels 1 and 3 with the Time Per Point settings shown. Channel 1 captured one full cycle with its Time Per Point setting of 500 nS and channel 3 captured two full cycles with its Time Per Point setting of 1.0 μ S.

Chapter 27

OPERATING

THE PRO 90

PRO 90 FEATURE ONLY

Using Dual Sample Rates

27-3

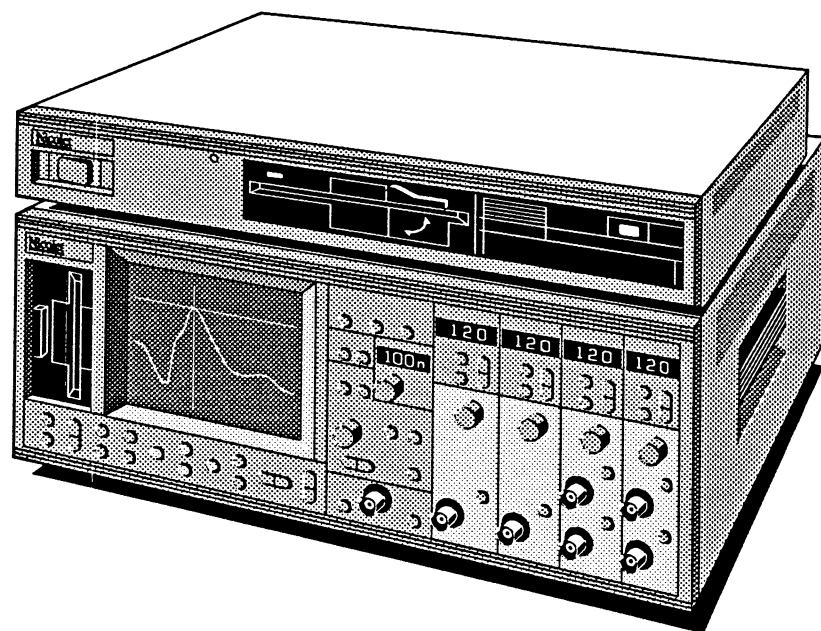

Pro 90 with two 8 bit, 200 mS/s, digitizers and two 12 bit, 10 MS/s digitizers

The four channel Pro 90 allows you to mix two different digitizers for dual sampling rates so that you can capture data with two high speed channels (200 MS/s, 8 bit digitizers) and two high resolution channels (10 MS/s, 12 bit digitizers).

The basic operation of each channel is identical to that as described in the preceding chapters of this manual. This chapter will describe the **Dual Sample Rates** feature and any other operating considerations you should be aware of when mixing digitizer types for signal acquisitions.

USING DUAL SAMPLE RATES

The **Dual Sample Rates** function allows the PRO 90 to simultaneously capture input signals sampled at two different rates. This dual timebase feature allows you to capture and observe both slow and fast events simultaneously.

For example, you can simultaneously capture up to two signals with the 8 bit, 200 MS/s digitizer channels and up to two signals with the 12 bit, 10 MS/s digitizer channels.

Note: Channels 1 and 2 always have identical Time Per Point settings. Likewise, channels 3 and 4 always share identical Time Per Point settings. For example, if you set channel 1 to 1.0 μ S, then channel 2 will also be set to 1.0 μ S.

1. Press the Menu button. The Menu screen appears (Figure 1).
2. Using the Cursor buttons, select the ACQUISITION menu and then select DUAL SAMPLE RATES as shown in Figure 1.
3. Press the Execute button. The Dual Sample Rates execution screen appears (Figure 2).
4. Press the Execute button. The waveform display returns.
5. Turn on the channels with which you want to capture input signals. You now can set the Time Per Point for the enabled channels as described on the next page.

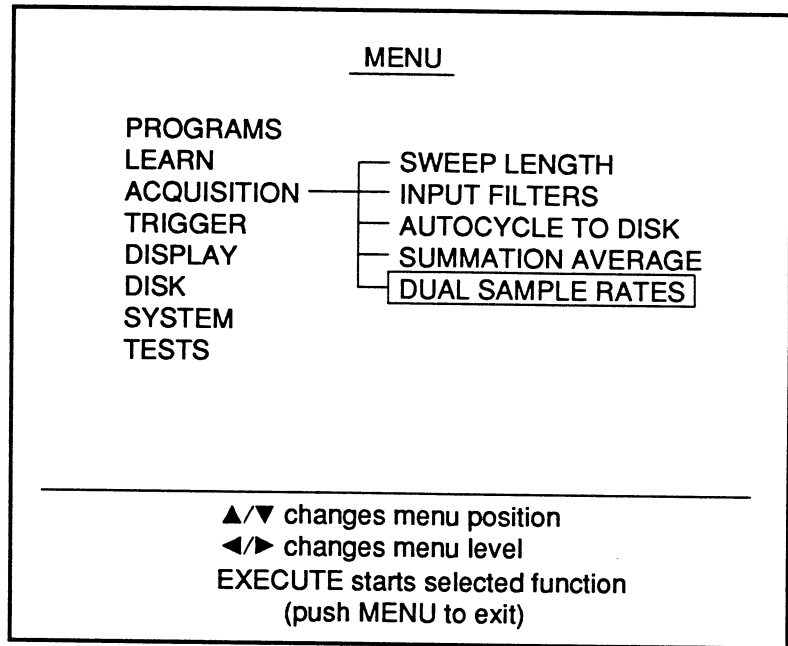

Figure 1 - Dual Sample Rates

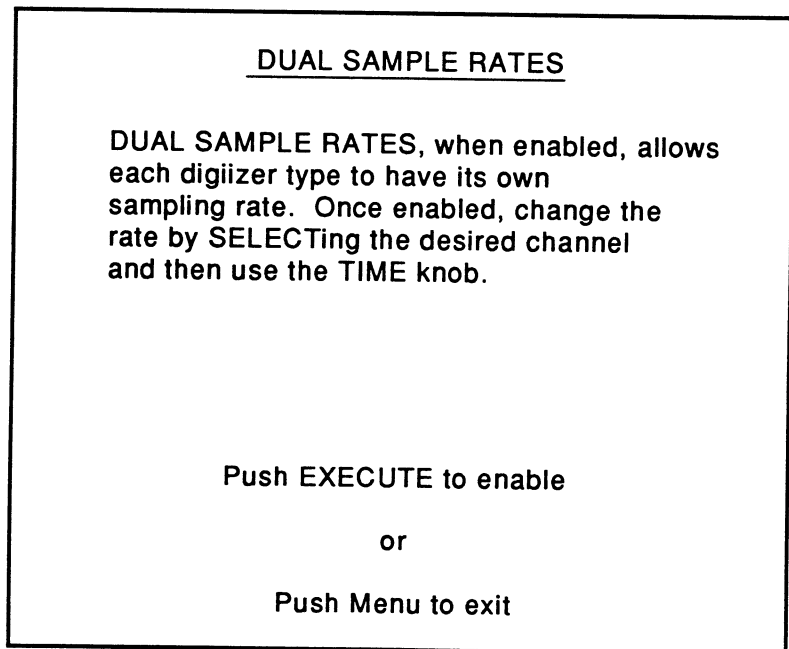

Figure 2 - Dual Sample Rates execution screen

6. To set the Time Per Point value for channels 1 and 2, highlight the left value (Figure 1) by pressing the Select button and then adjusting the Time control knob until the desired setting appears.
7. To set the Time Per Point value for channels 3 and 4, highlight the right value by pressing the Select button and then adjusting the Time control knob.
8. If you are not using External triggering, select the channel with the fastest Time Per Point setting as the trigger source.

For example, if you set channel 1 to 500 nS and channel 3 to 1.0 μS as shown in Figure 1, select channel 1 as the trigger source.

You can read time and voltage values directly from the numerics in the normal manner by pressing the Select button until the desired waveform is highlighted. The Channel Identifier will identify which channel captured the selected waveform and the Time numerics will decode time values accordingly for the Time Per Point setting that was used to capture the waveform.

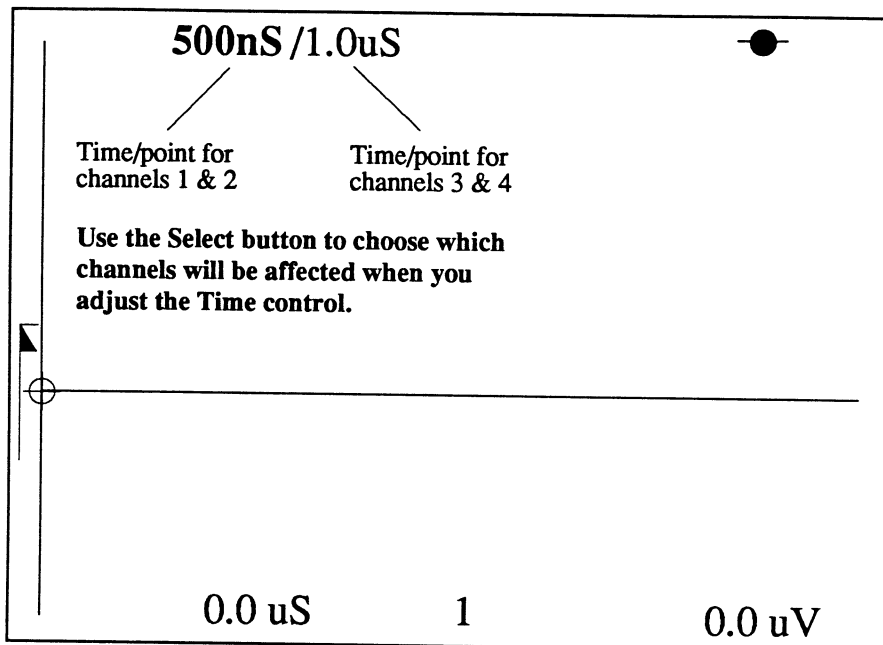

Figure 1 - The Time Per Point has been set to 500 nS for channels 1 and 2, and 1.0 μS for channels 3 and 4 in this example. The Select button is used to choose which pair of channels will be set by adjusting the Time control.

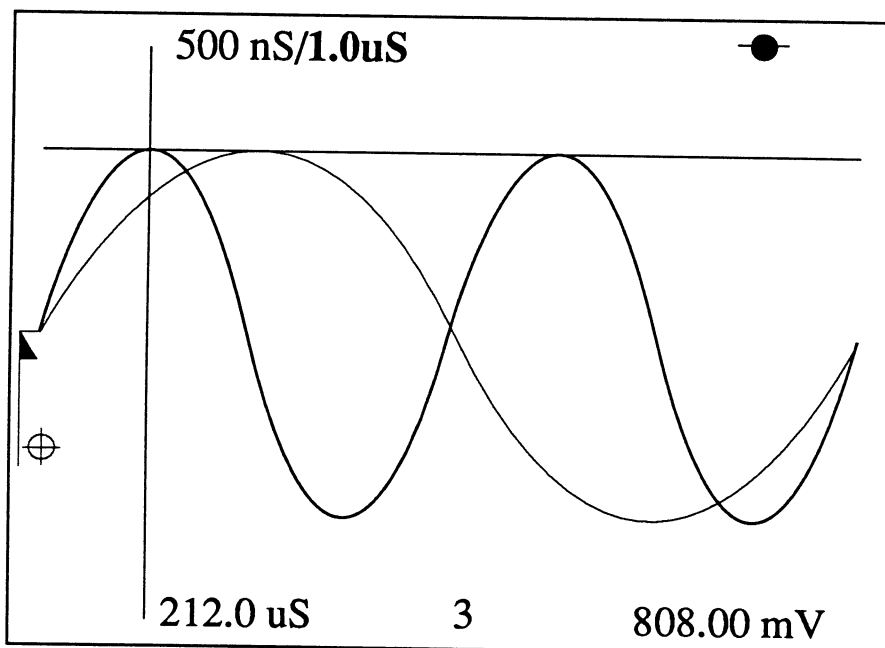

Figure 2 - Two identical signals were input to channels 1 and 3 with the Time Per Point settings shown. Channel 1 captured one full cycle with its Time Per Point setting of 500 nS and channel 3 captured two full cycles with its Time Per Point setting of 1.0 μS.

Chapter 28

APPENDIX

Rackmount Instructions	28-3
Preparing the Scope	28-4
Mounting the Pro Disk to your Scope	28-4
Connecting the Power (and SCSI) Cables	28-5
Mounting the Assembly	28-6

This chapter contains additional useful information about your instrument.

RACKMOUNT INSTRUCTIONS

These instructions are used to rackmount your Pro Series digital oscilloscope with or without a Nicolet Pro Disk.

The optional rackmount accessory is available from Nicolet; part number 845-400RM.

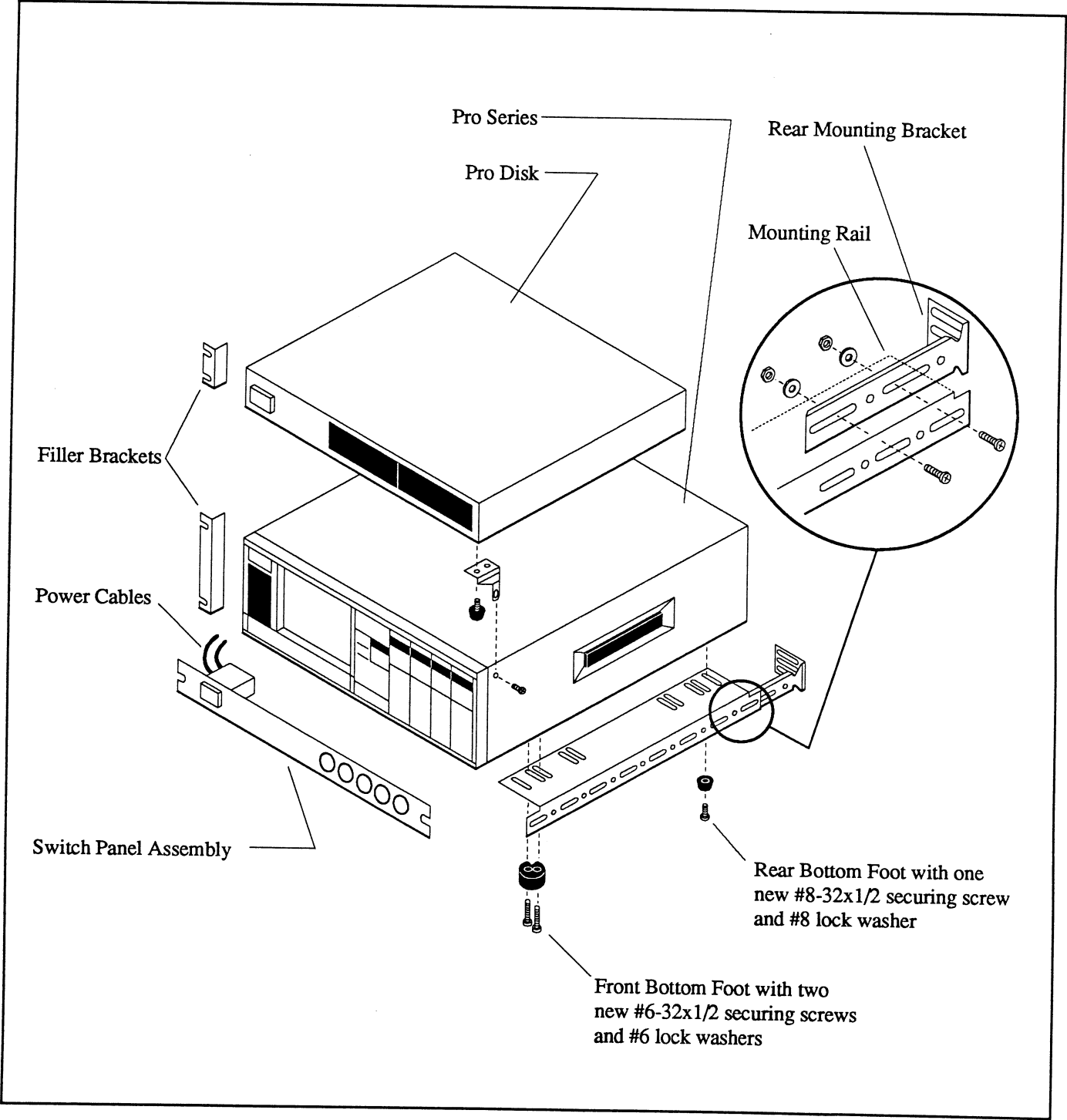

PREPARING THE SCOPE

WARNING: Remove all power from the instrument(s) before continuing.

1. Attach (1) Rear Mounting Bracket (P/N 011-9275) to the Mounting Rail (P/N 034-9046) with (2) #10-32x1/2 screws, flat washers and nuts in the appropriate slots for your rack configuration/dimensions (Figure 1). Tighten the screws securely.
2. Attach the Rail/Bracket Assembly from step 1 to the rack with the appropriate hardware provided (clip nuts, etc.).
3. Repeat steps 1 and 2 for the other side of the scope. Rotate the parts such that they are properly oriented to mount to the left side of the rack (mirror image to that as shown in Figure 1 for the right side).
4. Remove and save the (4) side bumpers from the left side of the scope.
5. Remove the (4) bottom feet from the scope. Store the bottom feet mounting screws away in a safe place, they are not used for rackmount systems.

MOUNTING THE PRO DISK TO YOUR SCOPE

Perform this procedure if your scope is configured with the Pro Disk.

6. Remove the two front, bottom feet from the Pro Disk Drive.
7. Attach the Hold Down Brackets to the Pro Disk using the bottom feet and securing screws removed in step 6 (Figure 2).
8. Mount the Pro Disk to the scope by securing the Hold Down Brackets to the threaded inserts at the top front of the scope outer cover (Figure 2). Use the #6-32x3/8 screws provided.

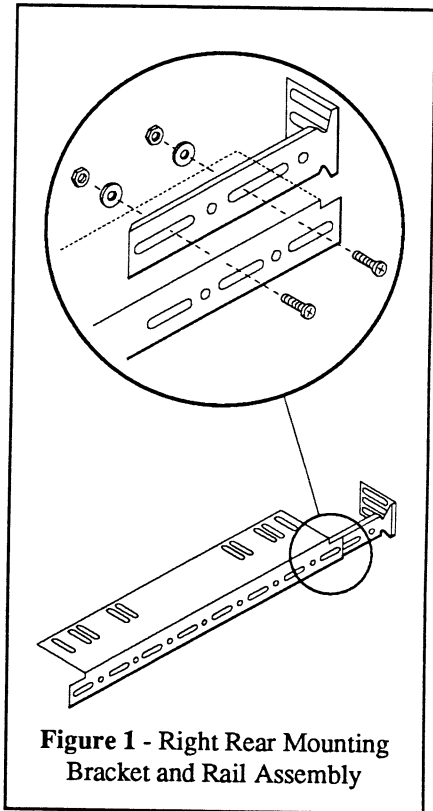

Figure 1 - Right Rear Mounting Bracket and Rail Assembly

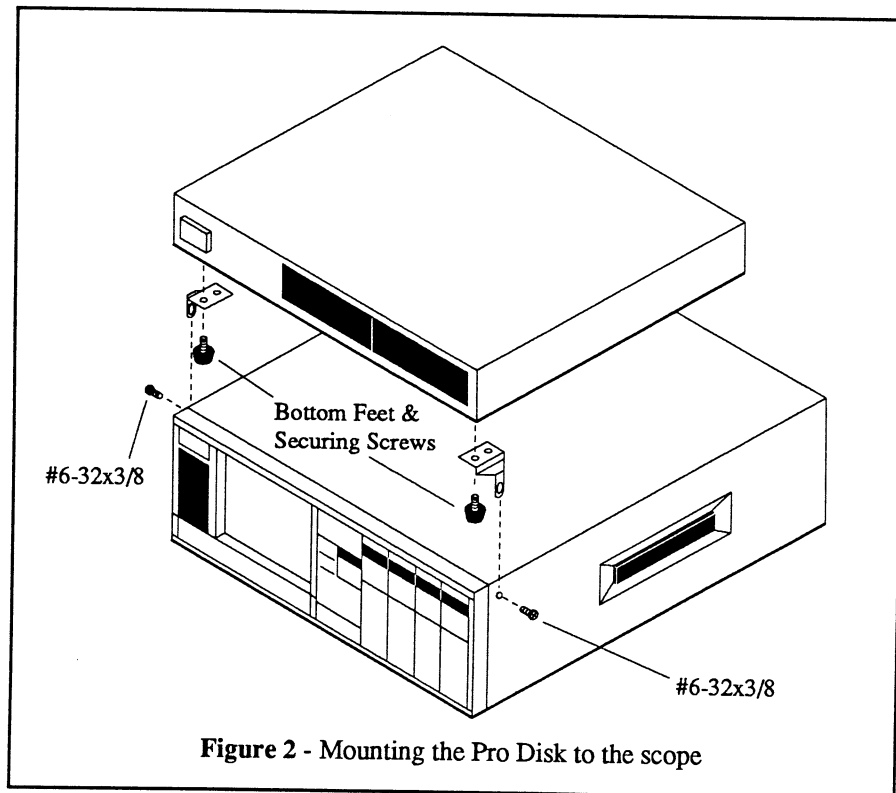

Figure 2 - Mounting the Pro Disk to the scope

CONNECTING THE POWER AND SCSI CABLES

9. Connect the shielded SCSI cable between the Pro Disk (Figure 1).
10. Using the short power cable provided with the Pro Disk, connect the power cable between the scope and Pro Disk (Figure 1).
11. Place the scope's rear panel power switch to the ON position.
12. Attach the Switch Panel Assembly with the panel screws provided (Figure 2).

Depending on whether or not the scope is configured with a Pro Disk, route the power cable (Figure 2) to power receptacle at the rear of either the scope or Pro Disk (Figure 1).

WARNING: See *Chapter 5* in this manual before proceeding to ensure that both of the instruments' power selectors match your power source.

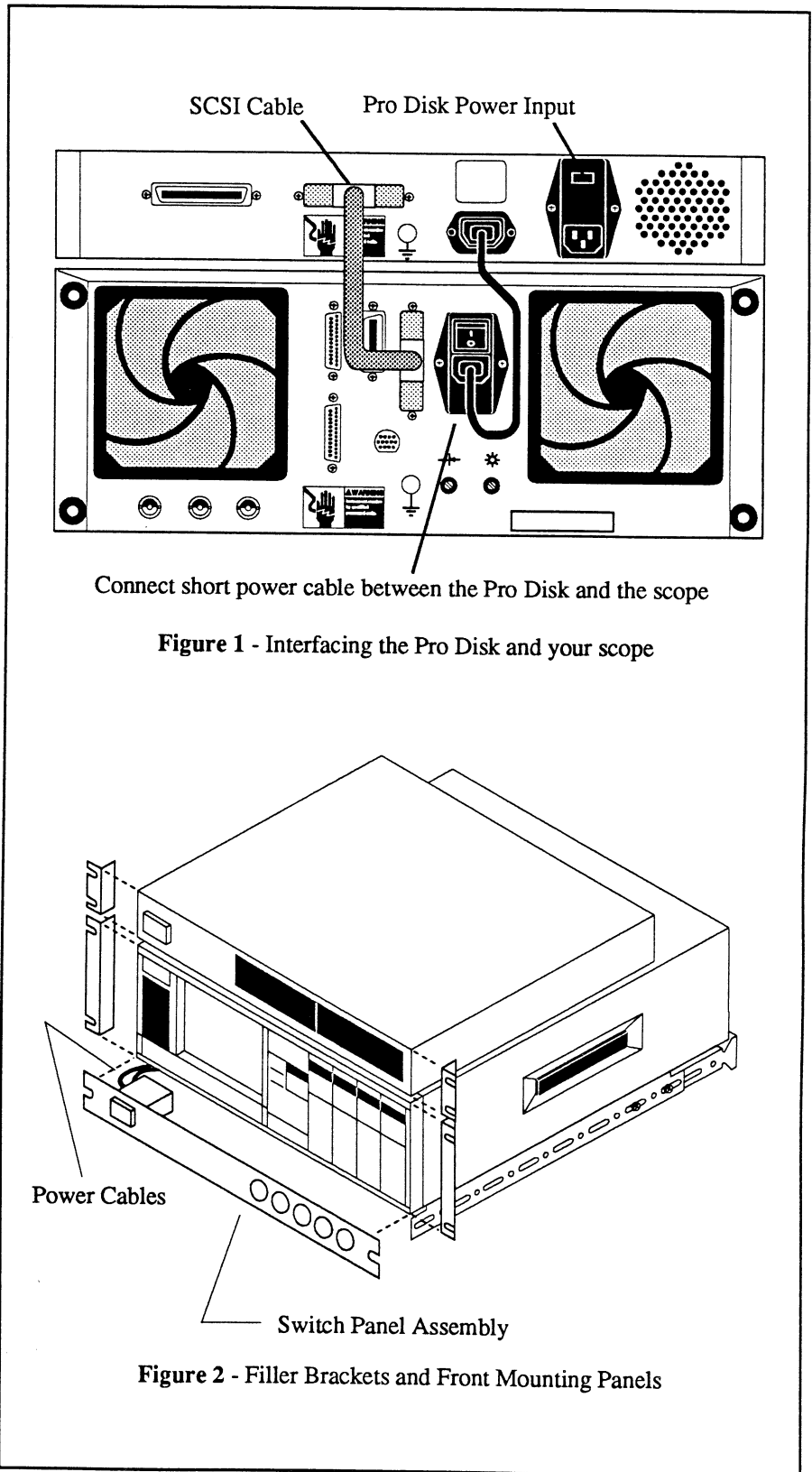

MOUNTING THE ASSEMBLY

13. Slide the assembly onto the rails already mounted in the rack.

WARNING: Use the bottom feet you removed during step 5 when securing the scope in step 14. Failure to do so may cause excessively long screws to short against internal circuit boards and damage the scope.

14. Attach the scope to the rails via the slots provided using the bottom feet (Figure 1) you removed in step 5 on page 28-4.
15. Attach the other power cable (Figure 2) from the front panel Switch Panel Assembly to the AC power source.
16. Attach the scope Filler Brackets (P/N 011-9275) to the Front Mounting Panel with the panel screws provided (Figure 2).
17. Attach the Pro Disk's Filler Brackets (P/N 011-9276) to the Front Mounting Panel with the panel screws provided (Figure 2).

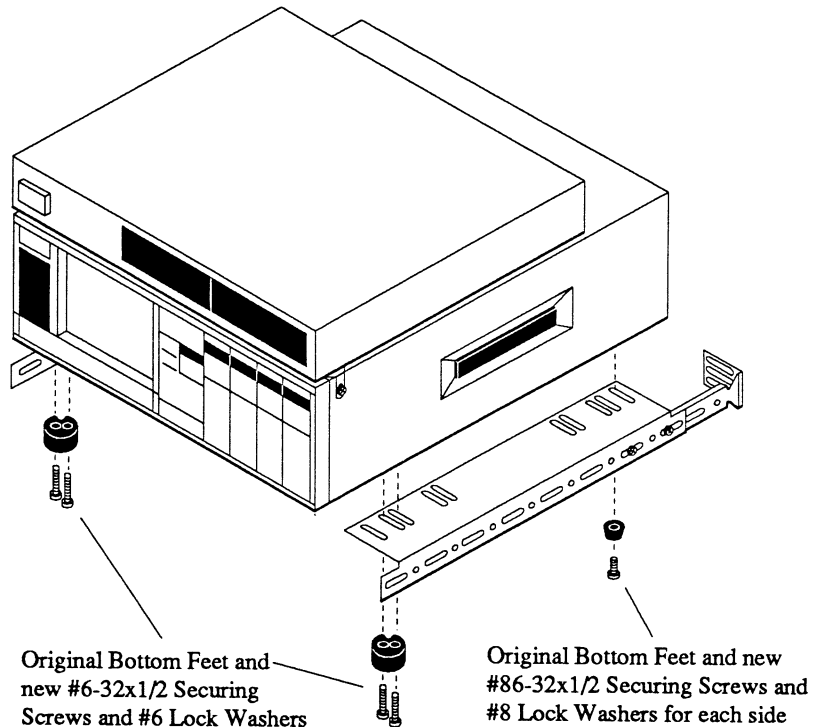

Figure 1 - Mounting the scope (shown with a Pro Disk) to the rails.

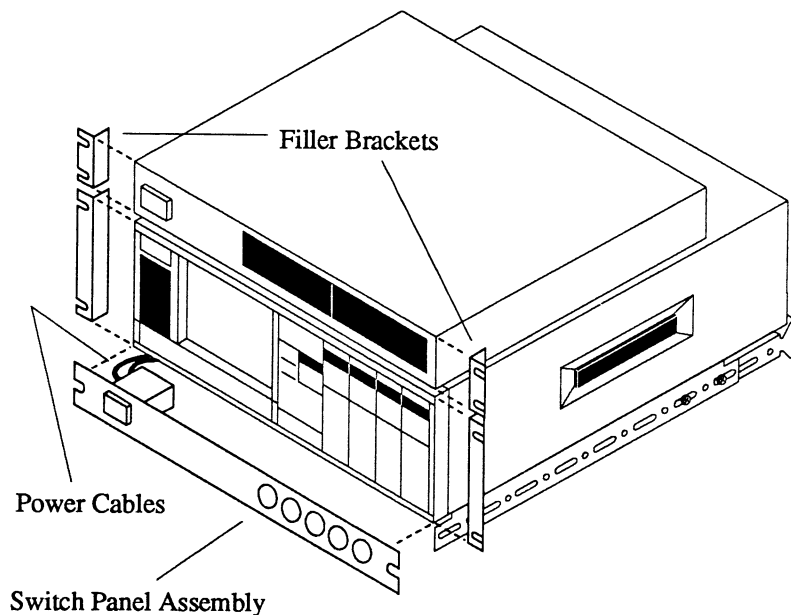

Figure 2 - Filler Brackets and Front Mounting Panels

Chapter 29

SPECIFICATIONS

This chapter contains your instrument's specifications.

Note: See page 29-15 for the Pro 90 (page 29-16 for the Pro 92 model) Trigger Specs when using the n Event, Hold Off, Glitch or Dropout triggering modes.

General Pro Series Specifications	29-2
Pro Disk Specifications	29-4
Pro 10 (Two 1 MS/s, 12-bit digitizers)	29-5
Pro 20 (Four 1 MS/s, 12-bit digitizers)	29-5
Pro 30 (Two 10 MS/s, 12-bit digitizers)	29-7
Pro 40 (Four 10 MS/s, 12-bit digitizers)	29-7
Pro 32 (Two 20 MS/s, 12-bit digitizers)	29-9
Pro 42 (Four 20 MS/s, 12-bit digitizers)	29-9
Pro 34 (Two 5 MS/s, 14-bit digitizers)	29-11
Pro 44 (Four 5 MS/s, 14-bit digitizers)	29-11
Pro 50 (Two 200 MS/s, 8-bit digitizers)	29-13
Pro 60 (Four 200 MS/s, 8-bit digitizers)	29-13
Pro 90 (Comprised of two pairs of the following digitizers)	
• Description and Trigger Specs	29-15
• With two 10 MS/s, 12-bit digitizers	29-7
• With two 200 MS/s, 8-bit digitizers	29-13
Pro 92 (Comprised of two pairs of the following digitizers)	
• Description and Trigger Specs	29-15
• With two 20 MS/s, 12-bit digitizers	29-9
• With two 200 MS/s, 8-bit digitizers	29-13

All performance measurements comply with IEEE Standard for Digitizing Waveform Recorders.

THE PRO SERIES

General Specifications

DISPLAY:	7-inch, high definition, 1000 x 1000 resolution
EXPANSION	
a. Horizontal:	Up to X5000, depends on record length
b. Vertical:	Up to X512
ARITHMETIC FUNCTIONS:	FFT and Summation Averaging. All other math functions are downloaded from 3.5" diskettes.
NUMERICS	
a. YT Display Mode:	Time and voltage plus channel identifier
b. XY Display Mode:	X-volts and Y-volts plus channel identifier
NUMERIC DISPLAYS (XY/YT)	
a. Normal:	Absolute numerics, time and voltage or user-defined units.
b. Reset Numerics:	Relative numerics.
c. Grid:	Numeric scale per grid mark.
AUTOCENTER	
a. Unexpanded Display:	Automatic lock of cursor to waveform.
b. Expanded Display:	Automatic waveform centering.
PROGRAMS	
a. FFT Snapshot	
• Record Length:	1000 points fixed
• Bandwidth:	For Pro 10, Pro 20: 500 kHz with 1 MS/s sample rate For Pro 30, Pro 40: 5 MHz with 10 MS/s sample rate For Pro 32, Pro 42: 10 MHz with 20 MS/s sample rate For Pro 34, Pro 44: 2.5 MHz with 5 MS/s sample rate For Pro 50, Pro 60: 100 MHz with 200 MS/s sample rate
• Data Display, Plot:	1000 points spectral magnitude only.
• Disk:	Real/Imaginary in .WFF format.
• I/O:	Access to magnitude only.
• Execution Time:	2.5 seconds
b. Summation Averaging:	High speed summation averaging of all active input channels with selectable Artifact Reject.
• Record Length:	101 - 19,000 (64 k/channel), 101 - 85,000 (256 k/channel)
• Max. Averaging Speed	1 channel, 1000 points record: 69 sweeps/second 4 channel, 1000 points record: 45 sweeps/second 1 channel, 10,000 points record: 31 sweeps/second 4 channel, 10,000 points record: 11 sweeps/second
• Maximum number of swps/average:	65,535 (any sweep length)

All performance measurements comply with IEEE Standard for Digitizing Waveform Recorders.

THE PRO SERIES

General Specifications

continued

DISK RECORDER

- a. Disk Recorder Type: 3-1/2" double sided, double density/high density, soft sectored micro floppy
- b. Storage Capacity: 720 K-bytes or 1.44 M-bytes
- c. Record Identification: On screen.
- d. Write Protection: Automatic, manual unprotect.
- e. Autocycle: Automatic, consecutive capture-and-store of records with the number of records dependent on record length.

PLOT:

- a. Output to digital plotters: HPGL plotters via IEEE-488 or RS-232 interface, or Centronix interface.
- b. Output to dot matrix printer: Epson-compatible or ThinkJet-compatible graphics printers via Centronix or RS-232 interface.
- c. Output to Laser Printers: Laser printers which support HPGL commands.

DIGITAL I/O

- a. Interfaces: GPIB, RS-232, Centronix, SCSI
- b. GPIB speed: Over 100 K-bytes/Sec continuous

AUTO-SETUP:

Minimum Frequency of 10 Hz. Selects voltage range, time-per-point, and trigger level of repetitive signals.

POWER

- a. Line Voltage: 90-132 VAC or 180-264 VAC, 1 phase
- b. Power: 450 W
- c. Frequency: 50 - 60 Hz $\pm 5\%$
- d. Current (max): 5A at 120 V, 2.5A at 240 V
- e. Fuse: 7A SLO BLO at 120 V, 4A SLO BLO at 240 V

DIMENSIONS (Approximate)

- a. Basic Frame: 17.5" (44.5cm) (W) x 7" (17.8cm) (H) x 23.25" (59.1cm) (D)
- b. With Side Bumpers: Add 0.5" (1.3cm) to Width
- c. With Bottom Bumpers: Add 0.625" (1.6cm) to Height
- d. Front Panel Knobs: Add 0.25" (0.6cm) to Depth
- e. Rack Mount option: Add 1.75" to height (total 8.75", 5 rack units)

WEIGHTS (Approximate)

- a. Pro 10: 40 pounds (18.2 kg)
- b. Pro 20: 45 pounds (20.5 kg)
- c. Pro 30: 40 pounds (18.2 kg)
- d. Pro 32: 40 pounds (18.2 kg)
- e. Pro 34: 40 pounds (18.2 kg)
- f. Pro 40: 45 pounds (20.5 kg)
- g. Pro 42: 45 pounds (20.5 kg)
- h. Pro 50: 40 pounds (18.2 kg)
- i. Pro 60: 45 pounds (20.5 kg)
- j. Pro 90: 45 pounds (20.5 kg)
- k. Pro 92: 45 pounds (20.5 kg)

All performance measurements comply with IEEE Standard for Digitizing Waveform Recorders.

PRO DISK OPTION

General Specifications

SCSI bus driven, multiple disk drive peripheral accessory box.

A maximum of three disk drives can be installed in a single Pro Disk.

All disks are MS-DOS format.

Floppy disk drives (Maximum of two)

- | | |
|--|---|
| a. 5.25 inch, double-sided, high density, soft sectored: | 1.2 Megabyte formatted, 500 K-bits/sec |
| b. 3.5 inch, double-sided, high density, soft sectored: | 1.44 Megabyte formatted, 500 K-bits/sec |

Fixed hard disk (Maximum of one)

- | |
|---|
| 3.5 inch, 40 M-byte formatted, SCSI interface |
| 3.5 inch, 80 M-byte formatted, SCSI interface |

Removable-media disk drive (Maximum of one)

- | | |
|---------------------------|--|
| a. IOMEGA Beta 44: | 5.25 inch, 44 M-byte formatted, SCSI interface |
| b. Magneto-optical drive: | 3.5 inch, 128 M-byte formatted, SCSI interface |

Dimensions (Approximate)

- | | |
|-------------------------|---|
| a. Basic Frame: | 17.5" (44.5cm)(W) x 2.75" (6.99cm)(H) x 18" (45.7cm)(D) |
| b. With Bottom Bumpers: | Add 0.25"(0.6cm) to height (H) |
| c. Rack Mount option: | Add 0.75" to height (total 3.5", 2 rack units) |

Weight (Approximate)

- | | |
|-------------------------------------|-----------------------|
| a. Pro Disk (Frame with no drives): | 13 pounds (5.9 kg) |
| b. 3.5" Floppy Disk Drive: | Add 1 pound (0.5 kg) |
| c. 5.25" Floppy Disk Drive: | Add 2.2 pounds (1 kg) |
| d. Fixed Hard Disk Drive: | Add 2 pounds (0.9 kg) |
| e. Removable Hard Disk Drive: | Add 4 pounds (1.8 kg) |

Power

- | | |
|-------------------|--|
| a. Line Voltage: | 90V - 132V or 180V - 264V, 1 phase |
| b. Power: | 100 volt-amperes (approximate) |
| c. Frequency: | 50 - 60 Hz \pm 5% |
| d. Current (max): | 0.6A at 120 V, 0.3A at 240 V |
| e. Fuse: | 2A SLO BLO at 120 V, 1A SLO BLO at 240 V |

All performance measurements comply with IEEE Standard for Digitizing Waveform Recorders.

PRO 10 (Two Channel)

PRO 20 (Four Channel)

With 12 bits, 1 MegaSamples per Second Digitizers

INPUTS:	Differential
a. Coupling:	AC, DC, GND (AC -3dB = 1.5 Hz \pm 10%)
b. Ranges (Full Scale):	30 mV to 120 V, 12 steps
c. Impedance:	1 Megohm \pm 2%, 50 pF
d. Zero Position Range:	0 to 100% Full Scale
SAFE OVERLOAD (all ranges):	240 VRMS and 360 V _{peak} (up to 500 Hz)
WARM-UP TIME:	One hour.
VERTICAL RESOLUTION:	12-bits (0.025%)
TIME BASE ACCURACY:	\pm 0.01%
EXTERNAL CLOCK:	500 kHz (max)
DIGITIZING RATE:	
a. Maximum	1 MegaSamples per second (1 μ S per point)
b. Minimum	0.1 Sample per second (10 seconds per point)
RECORD LENGTH:	256K Samples per channel (64K Optional)
DC GAIN ERROR:	\pm 0.15%
OFFSET ERROR	
a. 300 mV to 120 V:	\pm 0.2% Full Scale
b. 30 mV to 120 mV:	\pm 2% Full Scale
STATIC INTEGRAL LINEARITY ERROR:	\pm 0.05% Full Scale
MAXIMUM STATIC ERROR	\pm 0.25% Full Scale
TEMPERATURE RANGE	
a. Storage:	0 to 50 °C
b. Operating:	15 to 35 °C (within which specifications hold)
BANDWIDTH (All ranges):	500 kHz (minimum)
RISE TIME (All ranges):	500 ns

All performance measurements comply with IEEE Standard for Digitizing Waveform Recorders.

PRO 10 (Two Channel)**PRO 20** (Four Channel)**With 12 bits, 1 MegaSamples per Second Digitizers**

RMS NOISE (open inputs)	
a. 30 mV to 120 mV:	±0.10% Full Scale
b. 300 mV to 120 V:	±0.025% Full Scale
COMMON MODE REJECTION	
a. DC:	-72 dB
b. 1 kHz:	-60 dB
c. 1 MHz:	-40 dB
COMMON MODE VOLTAGE RANGE (DC + Peak AC)	
a. 30 mV to 1.2 V:	±5 Volts
b. 3 V to 12 V:	±50 Volts
c. 30 V to 120 V:	±100 Volts
FILTER (Switchable):	100 kHz ±10%
DIGITAL INTERNAL TRIGGER RANGE:	Trigger Range = Input Range
INTERNAL TRIGGER SENSITIVITY:	12 bit Digital Trigger Sensitivity = $(1/4096) \times$ (input range)
INTERNAL TRIGGER ACCURACY:	Same as input measurement accuracy
INTERNAL TRIGGER BANDWIDTH:	Equal to input bandwidth
EXTERNAL TRIGGER RANGE:	12 Volts Full Scale
EXTERNAL TRIGGER SENSITIVITY:	200 mVp-p to 12 V Full Scale
EXTERNAL TRIGGER FREQUENCY (Max) External input (50% F. S.):	100 MHz
TRIGGER DELAY (Max)	
a. Pre-trigger:	99% of Screen
b. Post-trigger:	$10^9 \times$ Selected Time Per Point
EXTERNAL TRIGGER LEVEL ACCURACY:	±2%
TRIGGER SPECS:	
a. n Event:	All times are minimum values. Maximum value is 40 seconds. (Not applicable for Adv Triggering modes)
b. Hold Off:	2 to 1 million events
c. Glitch:	External = 20 ns, Channel = 2 μs
d. Dropout (without Rearm):	External = 20 ns, Channel = 3 μs External = 60 ns, Channel = 3 μs

All performance measurements comply with IEEE Standard for Digitizing Waveform Recorders.

PRO 30 (Two Channel) PRO 40 (Four Channel)

With 12 bits, 10 MegaSamples per Second Digitizers

INPUTS:	Differential
a. Coupling:	AC, DC, GND (AC -3dB = 1.5 Hz \pm 10%)
b. Ranges (Full Scale):	30 mV to 120 V, 12 steps
c. Impedance:	1 Megohm \pm 2%, 50 pF
d. Zero Position Range:	0 to 100% Full Scale
SAFE OVERLOAD (all ranges):	240 VRMS and 360 Vpeak (up to 500 Hz)
WARM-UP TIME:	One hour.
VERTICAL RESOLUTION:	12-bits (0.025%)
TIME BASE ACCURACY:	\pm 0.01%
EXTERNAL CLOCK:	2 MHz (max)
DIGITIZING RATE:	
a. Maximum	10 MegaSamples per second (100 nS per point)
b. Minimum	0.1 Sample per second (10 seconds per point)
RECORD LENGTH:	256K Samples per channel (1M Optional)
DC GAIN ERROR:	\pm 0.15%
OFFSET ERROR	
a. 300 mV to 120 V:	\pm 0.2% Full Scale
b. 30 mV to 120 mV:	\pm 2% Full Scale
STATIC INTEGRAL LINEARITY ERROR:	\pm 0.05% Full Scale
MAXIMUM STATIC ERROR	\pm 0.25% Full Scale
TEMPERATURE RANGE	
a. Storage:	0 to 50 °C
b. Operating:	15 to 35 °C (within which specifications hold)
BANDWIDTH	
a. 30 mV to 120 mV:	500 kHz (minimum)
b. 300 mV to 120 V:	5 MHz (minimum)
RISE TIME	
a. 30 mV to 120 mV:	500 ns
b. 300 mV to 120 V:	100 ns

All performance measurements comply with IEEE Standard for Digitizing Waveform Recorders.

PRO 30 (Two Channel)**PRO 40 (Four Channel)****With 12 bits, 10 MegaSamples per Second Digitizers****RMS NOISE (open inputs)**

a. 30 mV to 120 mV:	±0.15% Full Scale
b. 300 mV to 120 V:	±0.03% Full Scale

COMMON MODE REJECTION

a. DC:	-72 dB
b. 1 kHz:	-60 dB
c. 1 MHz:	-40 dB

COMMON MODE VOLTAGE RANGE

a. 30 mV to 1.2 V:	(DC + Peak AC) ±5 Volts
b. 3 V to 12 V:	±50 Volts
c. 30 V to 120 V:	±100 Volts

FILTER (Switchable):

100 kHz ±10%

DIGITAL INTERNAL TRIGGER RANGE:

Trigger Range = Input Range

INTERNAL TRIGGER SENSITIVITY:12 bit Digital Trigger Sensitivity adjustable from
($1/4096$) x (input range) to full scale**INTERNAL TRIGGER ACCURACY:**

Same as input measurement accuracy

INTERNAL TRIGGER BANDWIDTH:

Equal to input bandwidth

EXTERNAL TRIGGER RANGE:

12 Volts Full Scale

EXTERNAL TRIGGER SENSITIVITY:

200 mVp-p to 12 V Full Scale

EXTERNAL TRIGGER FREQUENCY (Max)

External input (50% F. S.):

100 MHz

TRIGGER DELAY (Max)

- a. Pre-trigger:
- b. Post-trigger:

99% of Screen
 10^9 x Selected Time Per Point

EXTERNAL TRIGGER LEVEL ACCURACY:

±2%

TRIGGER SPECS:

- a. n Event:
- b. Hold Off:
- c. Glitch:
- d. Dropout (without Rearm):

All times are minimum values. Maximum value is 40 seconds.
 (Not applicable for Adv Triggering modes)
 2 to 1 million events
 External = 20 ns, Channel = 300 ns
 External = 20 ns, Channel = 300 ns
 External = 60 ns, Channel = 300 ns

All performance measurements comply with IEEE Standard for Digitizing Waveform Recorders.

PRO 30 (Two Channel)

PRO 40 (Four Channel)

With 12 bits, 10 MegaSamples per Second Digitizers

INPUTS:	Differential
a. Coupling:	AC, DC, GND (AC -3dB = 1.5 Hz \pm 10%)
b. Ranges (Full Scale):	30 mV to 120 V, 12 steps
c. Impedance:	1 Megohm \pm 2%, 50 pF
d. Zero Position Range:	0 to 100% Full Scale
SAFE OVERLOAD (all ranges):	240 VRMS and 360 V _{peak} (up to 500 Hz)
WARM-UP TIME:	One hour.
VERTICAL RESOLUTION:	12-bits (0.025%)
TIME BASE ACCURACY:	\pm 0.01%
EXTERNAL CLOCK:	2 MHz (max)
DIGITIZING RATE:	
a. Maximum	10 MegaSamples per second (100 nS per point)
b. Minimum	0.1 Sample per second (10 seconds per point)
RECORD LENGTH:	64K Samples per channel (256K Optional)
DC GAIN ERROR:	\pm 0.15%
OFFSET ERROR	
a. 300 mV to 120 V:	\pm 0.2% Full Scale
b. 30 mV to 120 mV:	\pm 2% Full Scale
STATIC INTEGRAL LINEARITY ERROR:	\pm 0.05% Full Scale
MAXIMUM STATIC ERROR	\pm 0.25% Full Scale
TEMPERATURE RANGE	
a. Storage:	0 to 50 °C
b. Operating:	15 to 35 °C (within which specifications hold)
BANDWIDTH	
a. 30 mV to 120 mV:	500 kHz (minimum)
b. 300 mV to 120 V:	5 MHz (minimum)
RISE TIME	
a. 30 mV to 120 mV:	500 ns
b. 300 mV to 120 V:	100 ns

All performance measurements comply with IEEE Standard for Digitizing Waveform Recorders.

PRO 30 (Two Channel)**PRO 40** (Four Channel)**With 12 bits, 10 MegaSamples per Second Digitizers**

RMS NOISE (open inputs)	
a. 30 mV to 120 mV:	±0.15% Full Scale
b. 300 mV to 120 V:	±0.03% Full Scale
COMMON MODE REJECTION	
a. DC:	-72 dB
b. 1 kHz:	-60 dB
c. 1 MHz:	-40 dB
COMMON MODE VOLTAGE RANGE (DC + Peak AC)	
a. 30 mV to 1.2 V:	±5 Volts
b. 3 V to 12 V:	±50 Volts
c. 30 V to 120 V:	±100 Volts
FILTER (Switchable):	100 kHz ±10%
DIGITAL INTERNAL TRIGGER RANGE:	Trigger Range = Input Range
INTERNAL TRIGGER SENSITIVITY:	12 bit Digital Trigger Sensitivity adjustable from $(1/4096) \times$ (input range) to full scale
INTERNAL TRIGGER ACCURACY:	Same as input measurement accuracy
INTERNAL TRIGGER BANDWIDTH:	Equal to input bandwidth
EXTERNAL TRIGGER RANGE:	12 Volts Full Scale
EXTERNAL TRIGGER SENSITIVITY:	200 mVp-p to 12 V Full Scale
EXTERNAL TRIGGER FREQUENCY (Max) External input (50% F. S.):	100 MHz
TRIGGER DELAY (Max)	
a. Pre-trigger:	99% of Screen
b. Post-trigger:	$10^9 \times$ Selected Time Per Point
EXTERNAL TRIGGER LEVEL ACCURACY:	±2%
TRIGGER SPECS:	
a. n Event:	All times are minimum values. Maximum value is 40 seconds. (Not applicable for Adv Triggering modes)
b. Hold Off:	2 to 1 million events
c. Glitch:	External = 20 ns, Channel = 300 ns
d. Dropout (without Rearm):	External = 20 ns, Channel = 300 ns External = 60 ns, Channel = 300 ns

All performance measurements comply with IEEE Standard for Digitizing Waveform Recorders.

PRO 32 (Two Channel)

PRO 42 (Four Channel)

With 12 bits, 20 MegaSamples per Second Digitizers

INPUTS:	Differential
a. Coupling:	AC, DC, GND (AC -3dB = 1.5 Hz \pm 10%)
b. Ranges (Full Scale):	30 mV to 120 V, 12 steps
c. Impedance:	1 Megohm \pm 2%, 50 pF
d. Zero Position Range:	0 to 100% Full Scale
SAFE OVERLOAD (all ranges):	240 VRMS and 360 Vpeak (up to 500 Hz)
WARM-UP TIME:	One hour.
VERTICAL RESOLUTION:	12-bits (0.025%)
TIME BASE ACCURACY:	\pm 0.01%
EXTERNAL CLOCK:	2 MHz (max)
DIGITIZING RATE:	
a. Maximum	20 MegaSamples per second (50 nS per point)
b. Minimum	0.1 Sample per second (10 seconds per point)
RECORD LENGTH:	1M Samples
DC GAIN ERROR:	\pm 0.15%
OFFSET ERROR	
a. 300 mV to 120 V:	\pm 0.2% Full Scale
b. 30 mV to 120 mV:	\pm 2% Full Scale
STATIC INTEGRAL LINEARITY ERROR:	\pm 0.05% Full Scale
MAXIMUM STATIC ERROR	\pm 0.25% Full Scale
TEMPERATURE RANGE	
a. Storage:	0 to 50 °C
b. Operating:	15 to 35 °C (within which specifications hold)
BANDWIDTH	
a. 30 mV to 120 mV:	500 kHz (minimum)
b. 300 mV to 120 V:	10 MHz (minimum)
RISE TIME	
a. 30 mV to 120 mV:	500 ns
b. 300 mV to 120 V:	50 ns

All performance measurements comply with IEEE Standard for Digitizing Waveform Recorders.

PRO 32 (Two Channel)**PRO 42** (Four Channel)**With 12 bits, 20 MegaSamples per Second Digitizers**

RMS NOISE (open inputs)	
a. 30 mV to 120 mV:	±0.15% Full Scale
b. 300 mV to 120 V:	±0.035% Full Scale
COMMON MODE REJECTION	
a. DC:	-72 dB
b. 1 kHz:	-60 dB
c. 1 MHz:	-40 dB
COMMON MODE VOLTAGE RANGE (DC + Peak AC)	
a. 30 mV to 1.2 V:	±5 Volts
b. 3 V to 12 V:	±50 Volts
c. 30 V to 120 V:	±100 Volts
FILTER (Switchable):	100 kHz ±10%
DIGITAL INTERNAL TRIGGER RANGE:	Trigger Range = Input Range
INTERNAL TRIGGER SENSITIVITY:	12 bit Digital Trigger Sensitivity adjustable from $(1/4096) \times$ (input range) to full scale
INTERNAL TRIGGER ACCURACY:	Same as input measurement accuracy
INTERNAL TRIGGER BANDWIDTH:	Equal to input bandwidth
EXTERNAL TRIGGER RANGE:	12 Volts Full Scale
EXTERNAL TRIGGER SENSITIVITY:	200 mVp-p to 12 V Full Scale
EXTERNAL TRIGGER FREQUENCY (Max) External input (50% F. S.):	100 MHz
TRIGGER DELAY (Max)	
a. Pre-trigger:	99% of Screen
b. Post-trigger:	$10^9 \times$ Selected Time Per Point
EXTERNAL TRIGGER LEVEL ACCURACY:	±2%
TRIGGER SPECS:	
a. n Event:	All times are minimum values. Maximum value is 40 seconds. (Not applicable for Adv Triggering modes) 2 to 1 million events
b. Hold Off:	External = 20 ns, Channel = 100 ns
c. Glitch:	External = 20 ns, Channel = 200 ns
d. Drop out (without Rearm):	External = 60 ns, Channel = 200 ns

All performance measurements comply with IEEE Standard for Digitizing Waveform Recorders.

PRO 34 (Two Channel)

PRO 44 (Four Channel)

With 14 bits, 5 MegaSamples per Second Digitizers

INPUTS:	Differential
a. Coupling:	AC, DC, GND (AC -3dB = 1.5 Hz \pm 10%)
b. Ranges (Full Scale):	30 mV to 120 V, 12 steps
c. Impedance:	1 Megohm \pm 2%, 50 pF
d. Zero Position Range:	0 to 100% Full Scale
SAFE OVERLOAD (all ranges):	240 VRMS and 360 V _{peak} (up to 500 Hz)
WARM-UP TIME:	One hour.
VERTICAL RESOLUTION:	14-bits (0.006%)
TIME BASE ACCURACY:	\pm 0.01%
EXTERNAL CLOCK:	2 MHz (max)
DIGITIZING RATE:	
a. Maximum	5 MegaSamples per second (200 nS per point)
b. Minimum	0.1 Sample per second (10 seconds per point)
RECORD LENGTH:	1M Samples
DC GAIN ERROR:	\pm 0.15%
OFFSET ERROR	
a. 300 mV to 120 V:	\pm 0.2% Full Scale
b. 30 mV to 120 mV:	\pm 2% Full Scale
STATIC INTEGRAL LINEARITY ERROR:	\pm 0.05% Full Scale
MAXIMUM STATIC ERROR	\pm 0.25% Full Scale
TEMPERATURE RANGE	
a. Storage:	0 to 50 °C
b. Operating:	15 to 35 °C (within which specifications hold)
BANDWIDTH	
a. 30 mV to 120 mV:	500 kHz (minimum)
b. 300 mV to 120 V:	2.5 MHz (minimum)
RISE TIME	
a. 30 mV to 120 mV:	500 ns
b. 300 mV to 120 V:	200 ns

All performance measurements comply with IEEE Standard for Digitizing Waveform Recorders.

PRO 34 (Two Channel)**PRO 44** (Four Channel)**With 14 bits, 5 MegaSamples per Second Digitizers**

RMS NOISE (open inputs)	
a. 30 mV to 120 mV:	±0.1% Full Scale
b. 300 mV to 120 V:	±0.025% Full Scale
COMMON MODE REJECTION	
a. DC:	-72 dB
b. 1 kHz:	-60 dB
c. 1 MHz:	-40 dB
COMMON MODE VOLTAGE RANGE (DC + Peak AC)	
a. 30 mV to 1.2 V:	±5 Volts
b. 3 V to 12 V:	±50 Volts
c. 30 V to 120 V:	±100 Volts
FILTER (Switchable):	100 kHz ±10%
DIGITAL INTERNAL TRIGGER RANGE:	Trigger Range = Input Range
INTERNAL TRIGGER SENSITIVITY:	12 bit Digital Trigger Sensitivity adjustable from $(1/4096) \times$ (input range) to full scale
INTERNAL TRIGGER ACCURACY:	Same as input measurement accuracy
INTERNAL TRIGGER BANDWIDTH:	Equal to input bandwidth
EXTERNAL TRIGGER RANGE:	12 Volts Full Scale
EXTERNAL TRIGGER SENSITIVITY:	200 mVp-p to 12 V Full Scale
EXTERNAL TRIGGER FREQUENCY (Max) External input (50% F. S.):	100 MHz
TRIGGER DELAY (Max)	
a. Pre-trigger:	99% of Screen
b. Post-trigger:	10 ⁹ x Selected Time Per Point
EXTERNAL TRIGGER LEVEL ACCURACY:	±2%
TRIGGER SPECS:	
a. n Event:	All times are minimum values. Maximum value is 40 seconds. (Not applicable for Adv Triggering modes)
b. Hold Off:	2 to 1 million events
c. Glitch:	External = 20 ns, Channel = 600 ns
d. Dropout (without Rearm):	External = 20 ns, Channel = 1 us External = 60 ns, Channel = 600 ns

All performance measurements comply with IEEE Standard for Digitizing Waveform Recorders.

PRO 50 (Two Channel)

PRO 60 (Four Channel)

With 8 bits, 200 MegaSamples per Second Digitizers

INPUTS:	Single-ended
a. Coupling:	AC, DC, GND (low freq. AC rolloff -3dB, 1.6 Hz)
b. Ranges (Full Scale):	60mV to 30V, 8 steps
c. Impedance:	1 Megohm $\pm 1\%$, 52 pF $\pm 10\%$
d. Zero Position Range:	0 to 100% Full Scale
SAFE OVERLOAD (all ranges):	240 VRMS and 360 V _{peak} (up to 500 Hz)
WARM-UP TIME:	One hour
VERTICAL RESOLUTION:	8-bits (0.4%)
TIME BASE ACCURACY:	$\pm 0.01\%$
EXTERNAL CLOCK:	20 MHz (max)
DIGITIZING RATE:	
a. Maximum	200 MegaSamples per second (5 ns per point)
b. Minimum	500 Samples per second (2 ms per point)
RECORD LENGTH:	64K Samples per channel (256K Optional)
DC GAIN ERROR:	$\pm 1.0\%$
OFFSET ERROR	$\pm 1.0\%$ Full Scale
STATIC INTEGRAL LINEARITY ERROR:	$\pm 0.6\%$ Full Scale
MAXIMUM STATIC ERROR	$\pm 1.5\%$ Full Scale
TEMPERATURE RANGE	
a. Storage:	0 to 50 °C
b. Operating:	15 to 35 °C (within which specifications hold)
BANDWIDTH (all ranges):	100 MHz (-3dB)
RISE TIME (all ranges):	3.5 nS

All performance measurements comply with IEEE Standard for Digitizing Waveform Recorders.

PRO 50 (Two Channel)

PRO 60 (Four Channel)

With 8 bits, 200 MegaSamples per Second Digitizers

RMS NOISE (open inputs)	
a. 5 ns:	1.0% Full Scale
b. 10 ns or slower:	0.6% Full Scale
FILTER (Switchable):	20 MHz (-3dB)
DIGITAL INTERNAL TRIGGER RANGE:	Trigger Range = Input Range
INTERNAL TRIGGER SENSITIVITY:	8 bit Digital Trigger Sensitivity adjustable from $(1/256) \times$ (input range) to full scale
INTERNAL TRIGGER ACCURACY:	Same as input measurement accuracy
INTERNAL TRIGGER BANDWIDTH:	Equal to input bandwidth
EXTERNAL TRIGGER RANGE:	12 Volts
EXTERNAL TRIGGER SENSITIVITY:	200 mVp-p to 12 V Full Scale
EXTERNAL TRIGGER FREQUENCY (Max)	
a. External input (50% F. S.):	100 MHz
TRIGGER DELAY (Max)	
a. Pre-trigger:	99% of Screen
b. Post-trigger:	$10^9 \times$ Selected Time Per Point
EXTERNAL TRIGGER LEVEL ACCURACY:	$\pm 2\%$
TRIGGER SPECS:	All times are minimum values. Maximum value is 40 seconds. (Not applicable for Adv Triggering modes)
a. n Event:	2 to 1 million events
b. Hold Off:	20 ns
c. Glitch:	20 ns
d. Dropout (without Rearm):	60 ns

All performance measurements comply with IEEE Standard for Digitizing Waveform Recorders.

PRO 90 (Four Channel)

With two 8 bits, 200 MegaSamples per Second Digitizers and two 12 bits, 10 MegaSamples per Second Digitizers

Pro 90 DIGITIZER SPECIFICATIONS

The Pro 90 model uses the same digitizers as the Pro 30/Pro 40 and Pro 50/Pro 60 models, thus allowing dual sampling rates to capture both slow and fast events simultaneously.

See pages 29-7 and 29-8 for the 12 bits, 10 MS/s digitizer specifications.

See pages 29-9 and 29-10 for the 8 bits, 200 MS/s digitizer specifications.

TRIGGER SPECS:	All times are minimum values. Maximum value is 40 seconds. (Not applicable for Adv Triggering modes)
a. n Event:	2 to 1 million events
b. Hold Off:	External = 20 ns, 8-Bit Channel = 20 ns 12-Bit Channel = 300 ns
c. Glitch:	External = 20 ns, 8-Bit Channel = 20 ns 12-Bit Channel = 300 ns
d. Dropout (without Rearm):	External = 60 ns, 8-Bit Channel = 60 ns 12-Bit Channel = 300 ns

All performance measurements comply with IEEE Standard for Digitizing Waveform Recorders.

PRO 92 (Four Channel)

**With two 8 bits, 200 MegaSamples per Second Digitizers
and two 12 bits, 20 MegaSamples per Second Digitizers**

Pro 92 DIGITIZER SPECIFICATIONS

The Pro 92 model uses the same digitizers as the Pro 32/Pro 42 and Pro 50/Pro 60 models, thus allowing dual sampling rates to capture both slow and fast events simultaneously.

See pages 29-9 and 29-10 for the 12 bits, 20 MS/s digitizer specifications.

See pages 29-11 and 29-12 for the 8 bits, 200 MS/s digitizer specifications.

RECORD LENGTH:	256K Samples Per Channel
TRIGGER SPECS:	All times are minimum values. Maximum value is 40 seconds. (Not applicable for Adv Triggering modes)
a. n Event:	2 to 1 million events
b. Hold Off:	External = 20 ns, 8-Bit Channel = 20 ns 12-Bit Channel = 300 ns
c. Glitch:	External = 20 ns, 8-Bit Channel = 20 ns 12-Bit Channel = 300 ns
d. Dropout (without Rearm):	External = 60 ns, 8-Bit Channel = 60 ns 12-Bit Channel = 300 ns

Chapter 29

SPECIFICATIONS

General Pro Series Specifications	29-2
Pro Disk Specifications	29-4
Pro 10 (Two 1 MS/s, 12-bit digitizers)	29-5
Pro 20 (Four 1 MS/s, 12-bit digitizers)	29-5
Pro 30 (Two 10 MS/s, 12-bit digitizers)	29-7
Pro 40 (Four 10 MS/s, 12-bit digitizers)	29-7
Pro 50 (Two 200 MS/s, 8-bit digitizers)	29-9
Pro 60 (Four 200 MS/s, 8-bit digitizers)	29-9
Pro 90 (Comprised of two pairs of the following digitizers)	
• Description and Trigger Specs	29-11
• With two 10 MS/s, 12-bit digitizers	29-7
• With two 200 MS/s, 8-bit digitizers	29-9

This chapter contains your instrument's specifications.

Note: The four channel Pro 90 is configured with two 12-bit, 10 MS/s digitizers and two 8-bit, 200 MS/s digitizers. Therefore, since these are the same digitizers used with the Pro 30/Pro 40 and Pro 50/Pro 60 models, use the specifications on pages 29-7 through 29-10 for the Pro 90 model. See page 29-11 for the Pro 90 Trigger Specs when using the n Event, Hold Off, Glitch or Dropout triggering modes.

All performance measurements comply with IEEE Standard for Digitizing Waveform Recorders.

THE PRO SERIES

General Specifications

DISPLAY:	7-inch, high definition.
EXPANSION	
a. Horizontal:	Up to X5000, depends on record length
b. Vertical:	Up to X512
ARITHMETIC FUNCTIONS:	FFT and Summation Averaging. All other math functions are downloaded from 3.5" diskettes.
NUMERICS	
a. YT Display Mode:	Time and voltage plus channel identifier
b. XY Display Mode:	X-volts and Y-volts plus channel identifier
NUMERIC DISPLAYS (XY/YT)	
a. Normal:	Absolute numerics, time and voltage or user-defined units.
b. Reset Numerics:	Relative numerics.
c. Grid:	Numeric scale per grid mark.
AUTOCENTER	
a. Unexpanded Display:	Automatic lock of cursor to waveform.
b. Expanded Display:	Automatic waveform centering.
PROGRAMS	
a. FFT Snapshot	
• Record Length:	1000 points fixed
• Bandwidth:	For Pro 10, Pro 20: 500 kHz with 1 MS/s sample rate For Pro 30, Pro 40: 5 MHz with 10 MS/s sample rate For Pro 50, Pro 60: 100 MHz with 200 MS/s sample rate
• Data	
Display, Plot:	1000 points spectral magnitude only.
Disk:	Real/Imaginary in .WFF format.
I/O:	Access to magnitude only.
Execution Time:	2.5 seconds
b. Summation Averaging:	High speed summation averaging of all active input channels with selectable Artifact Reject.
• Record Length:	101 - 19,000 (64 k/channel), 101 - 85,000 (256 k/channel)
• Max. Averaging Speed	1 channel, 1000 points record: 147 sweeps/second 4 channel, 1000 points record: 77 sweeps/second 1 channel, 10,000 points record: 42 sweeps/second 4 channel, 10,000 points record: 13 sweeps/second
◦ Maximum number of swps/average:	65,535 (any sweep length)

All performance measurements comply with IEEE Standard for Digitizing Waveform Recorders.

THE PRO SERIES

General Specifications

continued

DISK RECORDER

- a. Disk Recorder Type: 3-1/2" double sided, double density/high density, soft sectored micro floppy
- b. Storage Capacity: 720 K-bytes or 1.44 M-bytes
- c. Record Identification: On screen.
- d. Write Protection: Automatic, manual unprotect.
- e. Autocycle: Automatic, consecutive capture-and-store of records with the number of records dependent on record length.

PLOT:

- a. Output to digital plotters: HPGL plotters via IEEE-488 or RS-232 interface, or Centronix interface.
- b. Output to dot matrix printer: Epson-compatible graphics printers via Centronix interface.

DIGITAL I/O

- a. Interfaces: GPIB, RS-232, Centronix, SCSI
- b. GPIB speed: Over 100 K-bytes/Sec continuous

AUTO-SETUP:

Minimum Frequency of 10 Hz. Selects voltage range, time-per-point, and trigger level of repetitive signals.

POWER

- a. Line Voltage: 90-132 VAC or 180-264 VAC, 1 phase
- b. Power: 450 W
- c. Frequency: 50 - 60 Hz $\pm 5\%$
- d. Current (max): 5A at 120 V, 2.5A at 240 V
- e. Fuse: 7A SLO BLO at 120 V, 4A SLO BLO at 240 V

DIMENSIONS (Approximate)

- a. Basic Frame: 17.5" (44.5cm) (W) x 7" (17.8cm) (H) x 23.25" (59.1cm) (D)
- b. With Side Bumpers: Add 0.5" (1.3cm) to Width
- c. With Bottom Bumpers: Add 0.625" (1.6cm) to Height
- d. Front Panel Knobs: Add 0.25" (0.6cm) to Depth

WEIGHTS (Approximate)

- a. Pro 10: 40 pounds (18.2 kg)
- b. Pro 20: 45 pounds (20.5 kg)
- c. Pro 30: 40 pounds (18.2 kg)
- d. Pro 40: 45 pounds (20.5 kg)
- e. Pro 50: 40 pounds (18.2 kg)
- f. Pro 60: 45 pounds (20.5 kg)
- g. Pro 90: 45 pounds (20.5 kg)

All performance measurements comply with IEEE Standard for Digitizing Waveform Recorders.

PRO DISK OPTION

General Specifications

SCSI bus driven, multiple disk drive peripheral accessory box.

A maximum of three disk drives can be installed in a single Pro Disk.

All disks are MS-DOS format.

Floppy disk drives (Maximum of two)

- | | |
|--|---|
| a. 5.25 inch, double-sided, high density, soft sectored: | 1.2 Megabyte formatted, 500 K-bits/sec |
| b. 3.5 inch, double-sided, high density, soft sectored: | 1.44 Megabyte formatted, 500 K-bits/sec |

Fixed hard disk (Maximum of one)

3.5 inch, 40 M-byte formatted, SCSI interface

Removable-media disk drive (Maximum of two)

- | | |
|--------------------|--|
| a. IOMEGA Beta 44: | 5.25 inch, 44 M-byte formatted, SCSI interface |
|--------------------|--|

Dimensions (Approximate)

- | | |
|-------------------------|---|
| a. Basic Frame: | 17.5" (44.5cm)(W) x 2.75" (6.99cm)(H) x 18" (45.7cm)(D) |
| b. With Bottom Bumpers: | Add 0.25"(0.6cm) to height (H) |

Weight (Approximate)

- | | |
|-------------------------------------|-----------------------|
| a. Pro Disk (Frame with no drives): | 13 pounds (5.9 kg) |
| b. 3.5" Floppy Disk Drive: | Add 1 pound (0.5 kg) |
| c. 5.25" Floppy Disk Drive: | Add 2.2 pounds (1 kg) |
| d. Fixed Hard Disk Drive: | Add 2 pounds (0.9 kg) |
| e. Removable Hard Disk Drive: | Add 4 pounds (1.8 kg) |

Power

- | | |
|-------------------|--|
| a. Line Voltage: | 90V - 132V or 180V - 264V, 1 phase |
| b. Power: | 100 volt-amperes (approximate) |
| c. Frequency: | 50 - 60 Hz \pm 5% |
| d. Current (max): | 0.6A at 120 V, 0.3A at 240 V |
| e. Fuse: | 2A SLO BLO at 120 V, 1A SLO BLO at 240 V |

All performance measurements comply with IEEE Standard for Digitizing Waveform Recorders.

PRO 10 (Two Channel)

PRO 20 (Four Channel)

With 12 bits, 1 MegaSamples per Second Digitizers

INPUTS:	Differential
a. Coupling:	AC, DC, GND (AC -3dB = 1.5 Hz \pm 10%)
b. Ranges (Full Scale):	30 mV to 120 V, 12 steps
c. Impedance:	1 Megohm \pm 2%, 50 pF
d. Zero Position Range:	0 to 100% Full Scale
SAFE OVERLOAD (all ranges):	240 VRMS and 360 Vpeak (up to 500 Hz)
WARM-UP TIME:	One hour.
VERTICAL RESOLUTION:	12-bits (0.025%)
TIME BASE ACCURACY:	\pm 0.01%
EXTERNAL CLOCK:	500 kHz (max)
DIGITIZING RATE:	
a. Maximum	1 MegaSamples per second (1 μ S per point)
b. Minimum	0.1 Sample per second (10 seconds per point)
RECORD LENGTH:	64K Samples per channel (256K Optional)
DC GAIN ERROR:	\pm 0.15%
OFFSET ERROR	
a. 300 mV to 120 V:	\pm 0.2% Full Scale
b. 30 mV to 120 mV:	\pm 2% Full Scale
STATIC INTEGRAL LINEARITY ERROR:	\pm 0.05% Full Scale
MAXIMUM STATIC ERROR	\pm 0.25% Full Scale
TEMPERATURE RANGE	
a. Storage:	0 to 50 $^{\circ}$ C
b. Operating:	15 to 35 $^{\circ}$ C (within which specifications hold)
BANDWIDTH (All ranges):	500 kHz (minimum)
RISE TIME (All ranges):	500 ns

All performance measurements comply with IEEE Standard for Digitizing Waveform Recorders.

PRO 10 (Two Channel)**PRO 20** (Four Channel)**With 12 bits, 1 MegaSamples per Second Digitizers**

RMS NOISE (open inputs)	
a. 30 mV to 120 mV:	±0.10% Full Scale
b. 300 mV to 120 V:	±0.025% Full Scale
COMMON MODE REJECTION	
a. DC:	-72 dB
b. 1 kHz:	-60 dB
c. 1 MHz:	-40 dB
COMMON MODE VOLTAGE RANGE	(DC + Peak AC)
a. 30 mV to 1.2 V:	±5 Volts
b. 3 V to 12 V:	±50 Volts
c. 30 V to 120 V:	±100 Volts
FILTER (Switchable):	100 kHz ±10%
DIGITAL INTERNAL TRIGGER RANGE:	Trigger Range = Input Range
INTERNAL TRIGGER SENSITIVITY:	12 bit Digital Trigger Sensitivity = $(1/4096) \times$ (input range)
INTERNAL TRIGGER ACCURACY:	Same as input measurement accuracy
INTERNAL TRIGGER BANDWIDTH:	Equal to input bandwidth
EXTERNAL TRIGGER RANGE:	12 Volts Full Scale
EXTERNAL TRIGGER SENSITIVITY:	200 mVp-p to 12 V Full Scale
EXTERNAL TRIGGER FREQUENCY (Max)	
External input (50% F. S.):	100 MHz
TRIGGER DELAY (Max)	
a. Pre-trigger:	99% of Screen
b. Post-trigger:	10 ⁹ x Selected Time Per Point
EXTERNAL TRIGGER LEVEL ACCURACY:	±2%
TRIGGER SPECS:	All times are minimum values. Maximum value is 40 seconds. (Not applicable for Adv Triggering modes)
a. n Event:	2 to 1 million events
b. Hold Off:	External = 20 ns, Channel = 2 μs
c. Glitch:	External = 20 ns, Channel = 3 μs
d. Dropout (without Rearm):	External = 60 ns, Channel = 3 μs

All performance measurements comply with IEEE Standard for Digitizing Waveform Recorders.

PRO 30 (Two Channel) PRO 40 (Four Channel)

With 12 bits, 10 MegaSamples per Second Digitizers

INPUTS:	Differential
a. Coupling:	AC, DC, GND (AC -3dB = 1.5 Hz \pm 10%)
b. Ranges (Full Scale):	30 mV to 120 V, 12 steps
c. Impedance:	1 Megohm \pm 2%, 50 pF
d. Zero Position Range:	0 to 100% Full Scale
SAFE OVERLOAD (all ranges):	240 VRMS and 360 Vpeak (up to 500 Hz)
WARM-UP TIME:	One hour.
VERTICAL RESOLUTION:	12-bits (0.025%)
TIME BASE ACCURACY:	\pm 0.01%
EXTERNAL CLOCK:	2 MHz (max)
DIGITIZING RATE:	
a. Maximum	10 MegaSamples per second (100 nS per point)
b. Minimum	0.1 Sample per second (10 seconds per point)
RECORD LENGTH:	64K Samples per channel (256K Optional)
DC GAIN ERROR:	\pm 0.15%
OFFSET ERROR	
a. 300 mV to 120 V:	\pm 0.2% Full Scale
b. 30 mV to 120 mV:	\pm 2% Full Scale
STATIC INTEGRAL LINEARITY ERROR:	\pm 0.05% Full Scale
MAXIMUM STATIC ERROR	\pm 0.25% Full Scale
TEMPERATURE RANGE	
a. Storage:	0 to 50 °C
b. Operating:	15 to 35 °C (within which specifications hold)
BANDWIDTH	
a. 30 mV to 120 mV:	500 kHz (minimum)
b. 300 mV to 120 V:	5 MHz (minimum)
RISE TIME	
a. 30 mV to 120 mV:	500 ns
b. 300 mV to 120 V:	100 ns

All performance measurements comply with IEEE Standard for Digitizing Waveform Recorders.

PRO 30 (Two Channel)**PRO 40** (Four Channel)**With 12 bits, 10 MegaSamples per Second Digitizers**

RMS NOISE (open inputs)	
a. 30 mV to 120 mV:	±0.15% Full Scale
b. 300 mV to 120 V:	±0.03% Full Scale
COMMON MODE REJECTION	
a. DC:	-72 dB
b. 1 kHz:	-60 dB
c. 1 MHz:	-40 dB
COMMON MODE VOLTAGE RANGE	(DC + Peak AC)
a. 30 mV to 1.2 V:	±5 Volts
b. 3 V to 12 V:	±50 Volts
c. 30 V to 120 V:	±100 Volts
FILTER (Switchable):	100 kHz ±10%
DIGITAL INTERNAL TRIGGER RANGE:	Trigger Range = Input Range
INTERNAL TRIGGER SENSITIVITY:	12 bit Digital Trigger Sensitivity adjustable from $(\frac{1}{4096}) \times (\text{input range})$ to full scale
INTERNAL TRIGGER ACCURACY:	Same as input measurement accuracy
INTERNAL TRIGGER BANDWIDTH:	Equal to input bandwidth
EXTERNAL TRIGGER RANGE:	12 Volts Full Scale
EXTERNAL TRIGGER SENSITIVITY:	200 mVp-p to 12 V Full Scale
EXTERNAL TRIGGER FREQUENCY (Max) External input (50% F. S.):	100 MHz
TRIGGER DELAY (Max)	
a. Pre-trigger:	99% of Screen
b. Post-trigger:	$10^9 \times$ Selected Time Per Point
EXTERNAL TRIGGER LEVEL ACCURACY:	±2%
TRIGGER SPECS:	All times are minimum values. Maximum value is 40 seconds. (Not applicable for Adv Triggering modes)
a. n Event:	2 to 1 million events
b. Hold Off:	External = 20 ns, Channel = 300 ns
c. Glitch:	External = 20 ns, Channel = 300 ns
d. Dropout (without Rearm):	External = 60 ns, Channel = 300 ns

All performance measurements comply with IEEE Standard for Digitizing Waveform Recorders.

PRO 50 (Two Channel)**PRO 60** (Four Channel)**With 8 bits, 200 MegaSamples per Second Digitizers**

INPUTS:	Single-ended
a. Coupling:	AC, DC, GND (low freq. AC rolloff -3dB, 1.6 Hz)
b. Ranges (Full Scale):	60mV to 30V, 8 steps
c. Impedance:	1 Megohm $\pm 1\%$, 52 pF $\pm 10\%$
d. Zero Position Range:	0 to 100% Full Scale
SAFE OVERLOAD (all ranges):	240 VRMS and 360 Vpeak (up to 500 Hz)
WARM-UP TIME:	One hour
VERTICAL RESOLUTION:	8-bits (0.4%)
TIME BASE ACCURACY:	$\pm 0.01\%$
EXTERNAL CLOCK:	20 MHz (max)
DIGITIZING RATE:	
a. Maximum	200 MegaSamples per second (5 ns per point)
b. Minimum	500 Samples per second (2 ms per point)
RECORD LENGTH:	64K Samples per channel (256K Optional)
DC GAIN ERROR:	$\pm 1.0\%$
OFFSET ERROR	$\pm 1.0\%$ Full Scale
STATIC INTEGRAL LINEARITY ERROR:	$\pm 0.6\%$ Full Scale
MAXIMUM STATIC ERROR	$\pm 1.5\%$ Full Scale
TEMPERATURE RANGE	
a. Storage:	0 to 50 °C
b. Operating:	15 to 35 °C (within which specifications hold)
BANDWIDTH (all ranges):	100 MHz (-3dB)
RISE TIME (all ranges):	3.5 nS

All performance measurements comply with IEEE Standard for Digitizing Waveform Recorders.

PRO 50 (Two Channel)**PRO 60** (Four Channel)**With 8 bits, 200 MegaSamples per Second Digitizers**

RMS NOISE (open inputs)	
a. 5 ns:	1.0% Full Scale
b. 10 ns or slower:	0.6% Full Scale
FILTER (Switchable):	20 MHz (-3dB)
DIGITAL INTERNAL TRIGGER RANGE:	Trigger Range = Input Range
INTERNAL TRIGGER SENSITIVITY:	8 bit Digital Trigger Sensitivity adjustable from $(\frac{1}{256}) \times$ (input range) to full scale
INTERNAL TRIGGER ACCURACY:	Same as input measurement accuracy
INTERNAL TRIGGER BANDWIDTH:	Equal to input bandwidth
EXTERNAL TRIGGER RANGE:	12 Volts
EXTERNAL TRIGGER SENSITIVITY:	200 mVp-p to 12 V Full Scale
EXTERNAL TRIGGER FREQUENCY (Max)	
a. External input (50% F. S.):	100 MHz
TRIGGER DELAY (Max)	
a. Pre-trigger:	99% of Screen
b. Post-trigger:	$10^9 \times$ Selected Time Per Point
EXTERNAL TRIGGER LEVEL ACCURACY:	$\pm 2\%$
TRIGGER SPECS:	All times are minimum values. Maximum value is 40 seconds. (Not applicable for Adv Triggering modes)
a. n Event:	2 to 1 million events
b. Hold Off:	20 ns
c. Glitch:	20 ns
d. Dropout (without Rearm):	60 ns

All performance measurements comply with IEEE Standard for Digitizing Waveform Recorders.

Specifications are subject to change without notice.

09-19-91
09-23-91

PRO 90 (Four Channel)

With two 8 bits, 200 MegaSamples per Second Digitizers and two 12 bits, 10 MegaSamples per Second Digitizers

Pro 90 DIGITIZER SPECIFICATIONS

The Pro 90 model uses the same digitizers as the Pro 30/Pro 40 and Pro 50/Pro 60 models, thus allowing dual sampling rates to capture both slow and fast events simultaneously.

See *pages 29-7 and 29-8* for the 12 bits, 10 MS/s digitizer specifications.

See *pages 29-9 and 29-10* for the 8 bits, 200 MS/s digitizer specifications.

TRIGGER SPECS:	All times are minimum values. Maximum value is 40 seconds. (Not applicable for Adv Triggering modes)
a. n Event:	2 to 1 million events
b. Hold Off:	External = 20 ns, 8-Bit Channel = 20 ns 12-Bit Channel = 300 ns
c. Glitch:	External = 20 ns, 8-Bit Channel = 20 ns 12-Bit Channel = 300 ns
d. Dropout (without Rearm):	External = 60 ns, 8-Bit Channel = 60 ns 12-Bit Channel = 300 ns

All performance measurements comply with IEEE Standard for Digitizing Waveform Recorders.

Chapter 30

INDEX

Symbols

1.44 megabyte diskette 23-3
720 kilobyte diskette 23-3
 $\Delta T/\Delta V$
 Button 9-17
 Default 9-17
 Marker 9-17
 Numerics 9-17
 Turned Off 7-2
 Turned On 7-2

A

Abort Mode 4-1
Aborting
 a Batch 16-4
 a Long Sweep 8-6
 a Plot 24-4
 the Recall Mode 23-12
 the Store Mode 23-7
About 21-8
AC Coupling 13-4
Accessing the Menus 14-2
Acquire 4-1
ACQUISITION MENU 17-1
Actual Data 26-3
Address 4-1
Adv Triggering 18-15
Advanced Trigger 13-32
 Markers 7-8
 ARM Marker 7-9
 TRG Marker 7-9
Aliasing 15-4
Amplifier Input BNCs 12-3
Amplitude Requirements 13-5
APPENDIX 28-1
Arm LED 13-32
ARM Marker 7-9
ASCII 4-1
ATN 25-5
Auto
 Set-Up Button 13-5
 Trigger Mode 13-4
Auto/Norm Button 13-4
Autocenter
 Button 9-14
 Marker 7-7, 8
Autocycle To Disk 17-5

B

Backup Battery 5-3
Batch File Requirements 16-6
Batches and the PC 16-6
Battery 5-3
Baud 4-1
Beeper 21-6
Bernoulli Cartridge 23-15
Bit 4-1
Bit Serial 4-1
BNC 4-1
Bus 4-1
Bypassing a Default File 23-8
Byte 4-1

C

Calculating the Sweep Time 10-9
Carriage Return 4-1
Cartridge Load/Unload LED 23-14
Cartridge Read/Write LED 23-14
CAUTIONS 3-1
CD 25-4
Change Plot Parameters Screen 24-6
Changing the Sweep Length 17-3
Changing Voltage Selector 5-1, 2
CHANNEL CONTROLS 12-1
Channel
 Identifier 7-4, 9-16
 Input BNCs 17-4
 On/Off Button 12-3
 Title 19-6
Character 4-1
Clear All Programs 15-6
Compensation Point 13-32
Continuous Cursor Movement 9-6
Controller 4-1
Controlling the Horizontal Cursor 9-3
Copy File 20-5
Coupling Buttons 12-4
Crosshair 7-3
CTS 25-4
Cursor
 Mode 19-2
 Time Lock 18-19
 Time Lock Marker 7-7
Cursor/Grid Options 19-2

D

- Data
 - Points 4-1
 - Set 4-1
 - Trigger Marker 7-4
 - Trigger Marker 13-18
 - Type 26-3
- DAV 25-5
- DC Coupling 13-4
- Default File 23-8
- Defining the Axes 11-5
- Delayed
 - Sweep 13-17
 - Sweep Marker 7-6
 - Sweep Mode 13-25
- Delete File 20-6
- Delimiter 4-1
- Deriving Triggers from a Single Source 13-29
- *DEVICE CLEAR* message 1-4
- Differential Amplifier Mode 12-3
- Digital Plot
 - Features 24-1
 - Options Screen 24-7
- Digitizer 4-1
- Digitizers 1-2
- DIP 4-1
- Directories 23-4
- Directory 20-8
- DISK DRIVES 23-1**
- DISK MENU 20-1**
- Disk Read/Write LED 23-14
- Diskette Format 23-3
- DISPLAY CONTROLS 9-1**
- DISPLAY MENU 19-1**
- DISPLAY SCREEN 7-1**
- Dot Join 19-3
- Dot-Join Marker 7-7, 8
- Drive
 - Designations 23-1, 23-12, 13
 - Specifier 23-4
- Drop Out Triggering 18-6
- Drop Out Triggering Marker 7-8
- DSR 25-4
- DTR 25-4
- Dual Sample Rates 17-10, 27-3
- Dual Slope 13-6
- Dual Slope Triggers 13-9

E

- End Of File (EOF) 4-1
- Entering New Trigger Parameters for Next Sweep 13-30
- EOI 25-5
- Execute Batch 16-4
- Executing
 - a Plot 24-5
 - a Point Label Plot 24-9
 - the Recall 23-12
- Exiting
 - the Menu Mode 14-2
 - the X/Y Display Mode 11-4
 - $\Delta T/\Delta V$ 9-17
- Expanding
 - a Full XY Waveform 11-7
 - an XY Segment 11-8
- Expansion
 - Brackets 9-9
 - Defaults 9-13
 - Marker 7-4, 9-9
- External
 - Clock 10-10
 - Input BNC 13-29
 - Input BNC 17-4
 - Trigger Coupling Button 13-4
 - Trigger Input BNC 13-4

F

- Feature Highlights 1-3
- FFT Snapshot 15-2
- File Header 26-3
- Fixed Hard Disk 23-14
- Floppy Disk 23-14
- Format Disk 20-7
- Formatting New Diskettes 23-6
- Frequency
 - Domain File 26-1
 - Domain Waveform Data Fields 26-7
- Front Panel Test 22-2
- Full Duplex 4-1
- Fuses 5-1, 2

G

Glitch Triggering 18-3
Glitch Triggering Marker 7-8
GLOSSARY OF TERMS 4-1
GPIB 4-1
Grid Mode 19-2
Guarding Data Stored in Memory 8-6

H

Half Duplex 4-1
Handshaking 4-2
High Res Auto Set-Up 21-7
Hold Last
 Button 8-4
 Mode 4-2, 8-4
Hold Mode 4-2, 8-6
Hold Next
 Button 8-5
 Mode 4-2, Mode 8-5
Hold Off
 Triggering 18-9
 Triggering Marker 7-8
Horiz Trigger Position Button 13-17
Horizontal & Vertical
 Expansion 9-7
 Expansion Combined 9-8
Horizontal
 Cursor 7-3
 Expansion 9-7
 Expansion Factors 9-11
 Expansion Only 9-8
 Expansion Turned OFF Before the XY Mod 11-6
Horizontally Expanding the Captured Waveform 10-6
HPIB 4-1

I

I/O 4-2
I/O Parameters 21-3
Identifying the Digitizers 1-2
IEEE-488 4-2
 (GPIB)Connector 25-5
 Plotter Interface 24-4
IFC 25-5
Independent Delays 18-21
Initialize MSO 20-4
Initiating the
 Recall Mode 23-12
 Store Mode 23-7
Input
 BNCs 12-3
Filters 17-4
Inspecting
 Expanded Waveforms 9-10
Y/T Displays 11-3
Inspection 2-2
Interface 4-2
Interfacing the
 Pro Disk and the Pro Series 23-13
 Scope 24-3, 4
 System 24-3
Intervals 18-2
INTRODUCTION 1-1
Introduction to Display Expansion 9-7

L

- LEARN MENU 16-1**
- LED 4-2
- Left/Right Cursor Buttons 9-4
- Level 13-3
- Level Control 13-7
- Level/Sens Lock 18-23
- Line Feed 4-2
- Line Fuses 5-2
- Live
 - Button 8-3
 - Mode 4-2, 8-3
- Loading the
 - Cartridge 23-14
 - Diskette 23-6, 14
- Locating the Zero Volts Reference 9-3
- Locating Zero Time 9-4
- LSB 4-2

M

- Making Menu Selections 14-3
- Master/Slave 18-24
- Max/Min 19-8
- Measuring $\Delta T/\Delta V$ Values 9-17
- Memory 4-2
- Mid Signal
 - Trigger 13-17
 - Trigger Sweep Mode 13-21
- Mixing Trigger Times and/or Trigger Modes 13-29
- Modem 4-2
- Mounting the Pro Disk to the Pro Series 23-17
- Moving the Vertical Cursor 9-4
- MSB 4-2
- Multiple
 - Storage Option (MSO) 23-13
 - Waveform Displays 11-3, 23-9

N

- n Event Triggering 18-12
- n Event Triggering Marker 7-8
- NDAC 25-5
- Negative
 - Logic 4-2
 - Slope 13-6
 - Slope Triggers 13-9
- Noise 4-2
- Normal
 - Setup Mode 13-19
 - Sweep 13-17
 - Trigger 13-32
 - Trigger Mode 13-4
- NRFD 25-5
- Numerics 4-2

O

- OPERATING THE PRO 90 27-1**
- Optical Drive and Cartridge 23-16
- 'OR' Triggering 18-22
- Overwriting an Existing File 23-8

P

Parallel Printer Cable 25-6
Parity Bit 4-2
Pathname 23-4
Pathname Definitions 23-4
Plot From Disk 20-9
Plotter Requirements 24-1
PLOTTING WAVEFORMS 24-1
Point Labeling Waveforms 24-9
Position Control 12-8
Positive
 Logic 4-2
 Slope 13-6
 Slope Triggers 13-9
POWER REQUIREMENTS 5-1
Power Interface 5-4
Print
 Batch 16-7
 Screen 19-7
Printer Output 21-4
PRO 90 & 92 27-1
Pro Models Information 1-1, 2; 10-3; 12-6; 27-1; 29-1
PROGRAMS MENU 15-1
Protecting Data on Diskette 23-6
Protective ground 25-4
Pulse Width < n 18-3
Pulse Widths 18-2

Q

Qualifying Successive Trigger 13-10

R

Rackmount Instructions 28-3
RDATA 25-4
Read 4-2
Reading
 Delayed Sweep Displays 13-25
 Diskettes in an IBM- PC 23-3
 Normal Sweep Displays 13-19
 Pre-trigger Sweep Displays 13-21
 Time on Delayed Sweeps with $\Delta T/\Delta V$ 13-26
 Time on Mid Signal Triggers with $\Delta T/\Delta V$ 13-22
 Time on Normal Sweeps with $\Delta T/\Delta V$ 13-20
 Triggering Parameters from the Last Sweep 13-30
REAR PANEL CONTROLS 25-1
Rear Panel Controls Summaries 25-3
Recall
 Batch 16-5
 Mode 23-12
 Procedure 23-12
 Program 15-5
 Setup 20-3
Recalling
 Front Panel Settings from RAM 21-2
 Waveforms for Display 23-11
Receiving 2-2
Recommended Cables 25-6
Record Separator 4-2
REN 25-5
Replacing the Fuses 5-2
Resetting the Instrument 1-4
RESIDENT MENUS 14-1
Resolution 4-2
Returning Cursors to the Slow Rate of Movement 9-6
Root Directory 23-5
RS-232 4-2
RS-232 Connector 25-4
RS232 Plotter Interface 24-3
RTS 25-4

S

- Sampling the Signal 10-3
- Save Ref Button 12-4
- SCSI 25-6
- SCSI Cables 28-5
- Select Button 9-16
- Selecting
 - a different waveform for inspection 9-16
 - a File for Recall 23-12
 - Cursor Speed 9-6
 - Delayed Sweep Displays in the Hold Mode 13-27
 - Delayed Sweep Displays in the Live Mode 13-28
 - Destination Channel 23-11
 - Input Coupling 12-4
 - Mid Signal Trigger Displays in the Hold 13-23
 - Mid Signal Trigger Displays in the Live 13-24
 - New Origins 9-17
 - Next Peak 9-3, 4
 - Next Valley 9-3, 4
 - Point Labels 24-9
 - Volts Full Scale Range 12-6
- Sensitivity Window 13-3
- Serial Data 4-3
- Set Date/Time 21-5
- Setting
 - Expansion Defaults 9-7
 - Sweep Length 10-8
 - Time 10-9
 - $\Delta T/\Delta V$ Default 9-17
 - Up the Plotter 24-3, 4
- Setup From RAM 21-2
- Setup To RAM 21-2
- Setup Trigger Marker 7-4, 13-18
 - Rate of Movement 13-18
- Signal Ground 25-4
- Single Waveform Displays 23-9
- Single-Ended Amplifier Mode 12-3
- Slope 13-3
- Slope, Level and Sensitivity Summaries 13-9
- Source 13-3
- Source Button 13-5
- SPECIFICATIONS 29-1**
- SRQ 25-5
- Stabilizing Recurrent Signal Displays 13-12
- Start
 - Bit 4-3
 - Learning 16-2
- Status
 - Button 13-30
 - Line 8-6
- Stepping the Cursors 9-6
- Stop
 - Bit 4-3
 - Learning 16-4
- STORAGE CONTROLS 8-1**
- Store
 - Batch 16-5
 - Mode 23-7
 - Procedure 23-10
 - Setup 20-2
- Storing
 - Front Panel Settings to RAM 21-2
 - Waveforms 23-7
- Subdirectories 23-5
- Successive Triggers 13-10
- Summation Average 17-9
- Sweep 4-3
 - Length 10-8, 17-2
 - Line 9-9
 - Review Memory 8-7
 - Review Mode 8-7
- SYSTEM MENU 21-1**

T

t=0 Trigger Default 13-18
TDATA 25-4
Test Probes 12-5
TESTS MENU 22-1
TIME CONTROL 10-1
Time Domain
 File 26-1
 Waveform Data Fields 26-4
To Cursor= 7-6
Tracing the Waveform with the Crosshair 9-4
Training Video 1-2
TRG Marker 7-9
Trgd LED 13-4, 13-32
TRIGGER CONTROLS 13-1
TRIGGER MENU 18-1
Trigger 4-3
 Default 13-18
 Level Marker 7-5
 Markers 13-18
 OR Marker 7-7
 Rate 18-2
 Sensitivity Marker 7-6
 Setup for (+/-) Slope Triggers 13-14
 Slope Button 13-6
 Slope Marker 7-5
Triggering Via
 Channel Input BNC 13-29
 External Input BNC 13-29
Troubleshooting Trigger Problems 13-16
Turnaround Delay 4-3
TUTORIAL 6-1

U

Unloading the
 Cartridge 23-14
 Diskette 23-14
Up/Down Cursor Buttons 9-3
User Units 19-4

V

Varying the
 Sweep Length 10-5
 Time Per Point 10-4
Vertical Cursor 7-3
Vertical Expansion 9-7
 Button 9-12
 Factors 9-12
 Only 9-8
View 7-6
View Button 13-5
Voltage Selector 5-1, 2
Volts
 Button 12-5
 Full Scale Range 12-6
 Readout 12-5
Volts-Per-Division 12-6
Volts-Per-Level 12-6

W**WARNINGS & CAUTIONS 3-1**

Warranty 2-1

WARRANTY, RECEIVING and INSPECTION 2-1**WAVEFORM FILE SPECIFICATIONS 26-1**

Waveform 7-3

File Names 23-5

Files 23-4

.WFF 26-1

.WFT 26-1

Wrapping-Around Cursors 9-6

X**XY**

Display Mode 11-4

Definition Screen 11-4

Expansion Factors 11-7, 8

Segment 11-8

XY/YT BUTTON 11-1**Y**

Y/T Display 11-3

Z**Zoom**

Factor 15-3

Factor and Aliasing 15-4

Installation of 3.5" R/W Optical

1. Copy the file ASPI4DOS.SYS to C:\.
2. Add the line DEVICE=C:\ASPI4DOS.SYS /D to the CONFIG.SYS file.
3. Reboot the system.
4. Insert the DOS Utilities disk and type A:\INSTALL. Follow instructions to install R/W Optical Software.
5. Reboot system and start Windows.

To format blank media double click on CFORMAT.EXE in the CORELDRV sub-directory or at the C:\> prompt type C:\CORELDRV\CFORMAT.EXE.

NOTE: Change the IRQ on the Adaptec SCSI host adapter to 15 when using it with the National Instrument 488 Board. Switches on host adapter should be set 1-4 open, and 4-8 closed.

ATTN:

Post-it® Fax Note	7671	Date	7/26	# of pages	▶ 1
To	Richard Harrison	From	Bart Morrisk		
Co./Dept.	Aberdeen Proving	Co.	Nicolet		
Phone #	410 278-4881	Phone #	608 276-5600		
Fax #	410 278-8517	Fax #			

TITLE <p style="text-align: center;">ProDisk Options</p>	PART NO. 267-0385 REV 03 PAGE 9 of 12
---	---

845-031900 - 128 Meg Optical Drive Option

1. This drive will always be installed in the right bay.

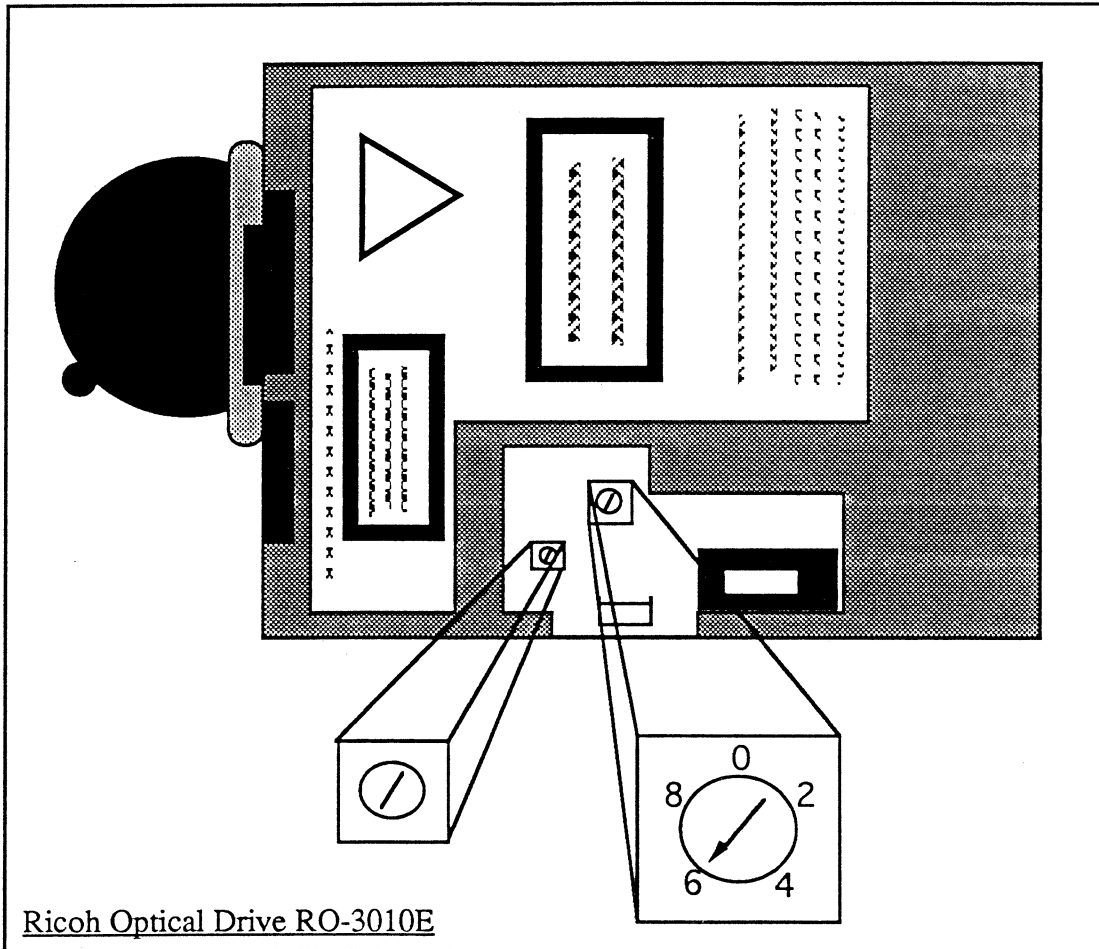

2. With a tweaker or small screw driver, set the two rotary switches as shown above if it is a Ricoh drive.
3. Install the two jumpers on the jumper block on the back of the unit as shown below if it is a Sony drive.

PRINTS TO	3090	SCPR				
DRAWN BY	Oftedahl	This document contains confidential or proprietary information of Nicolet Instrument Technologies. Neither this document nor the information therein is to be reproduced, distributed, used or disclosed, either in whole or in part, except as specifically authorized by Nicolet Instrument Technologies.				
DATE	3-25-93					

<p>TITLE</p> <p style="text-align: center;">ProDisk Options</p>	<p>PART NO. 267-0385</p> <p>PAGE 10 of 12</p>	<p>REV 03</p>
---	---	---------------

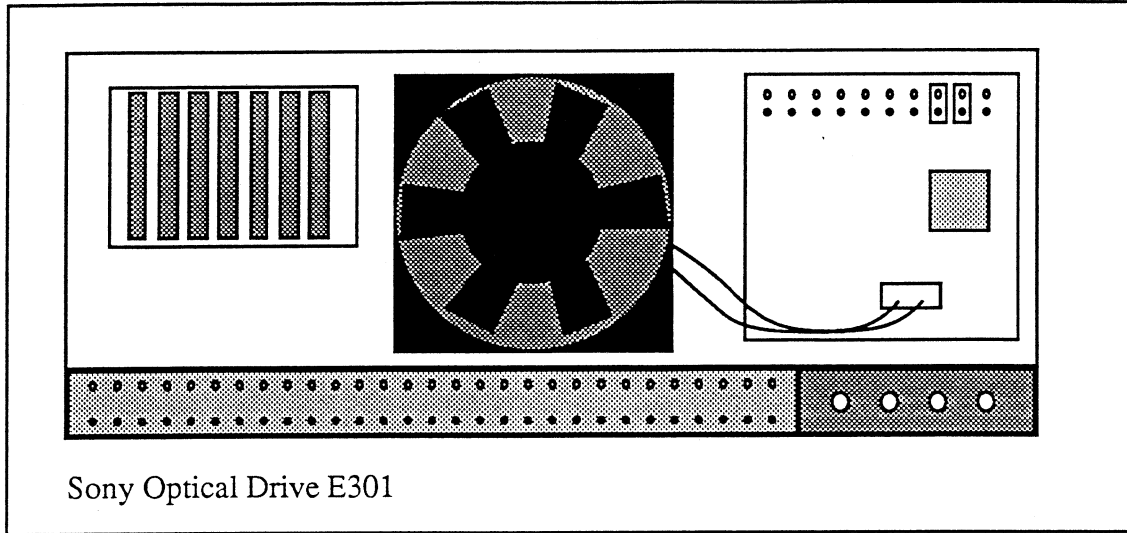

4. Slide the optical drive into the adapter, 268-756800, from the back. There is only one way the drive will fit so that the holes line up. Fasten with four 225-M0300050 screws.
5. Slide the drive into the frame through the front and attach to the frame using four ~~232-M30800~~ screws with four 242-080000 washers.

222-0632050

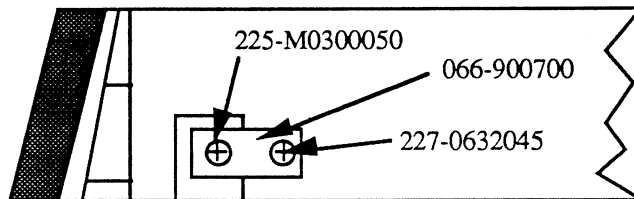

6. Attach the ground strap 066-900700 using one 227-0632045 screw and one 225-M0300050 as shown above.
7. Attach the drive cable, 085-936101, and the power cable, 405-017300, to the drive. Pull a 128 Meg cartridge, 277-001500, and keep it with the ProDisk assembly.
8. Check the work order for any other drive options and proceed to the appropriate section, otherwise go to the section on finishing.

PRINTS TO	3090	SCPR				
DRAWN BY	Oftedahl	<p>This document contains confidential or proprietary information of Nicolet Instrument Technologies. Neither this document nor the information therein is to be reproduced, distributed, used or disclosed, either in whole or in part, except as specifically authorized by Nicolet Instrument Technologies.</p>				
DATE	3-25-93					