

JESUS,
KING ARTHUR,
AND THE
JOURNEY OF THE GRAIL

THE SECRETS
OF THE
SUN KINGS



Maurice Cotterell

The
CELTIC
CHRONICLES

The True Story of the Holy Grail



MAURICE COTTERELL

Bestselling author of The Tutankhamon Prophecies & The Last Tomb of Viracocha

JESUS,
KING ARTHUR,
AND THE
JOURNEY OF THE GRAIL

THE SECRETS
OF THE
SUN KINGS



Maurice Cotterell
Bestselling author of *The Tutankhamun Prophecies*

The
CELTIC
CHRONICLES

The True Story of the Holy Grail



MAURICE COTTERELL

Bestselling author of *The Tutankhamun Prophecies* & *The Lost Tomb of Viracocha*

Jesus,
King Arthur,
and the
Journey of the Grail

Little is known about the Celts—the *Keltoi*—the blonde-haired blue-eyed *secret* people of Europe.

For hundreds of years scholars, baffled by strange carvings and Celtic treasures of gold, silver, precious glass and holy books, have tried to make sense of one of the world's most enigmatic people. Some see their legacy as the 'works of Angels'. Others, entranced, claim their achievements imply access to technologies that surpass our own of today.

Now, Maurice Cotterell breaks the codes of the Celts as he tracks and trails them from their first appearance in the Taklamakan desert of China, across Europe, to Ireland, and lifts the veil of mystery.

He shows that the Celts, like the Mayas, Peruvians, Egyptians, and Chinese, understood the super-science of the Sun and the higher orders of spirituality and encoded their knowledge into their treasures for re-discovery in a future incarnation, should they fail to make it to Heaven this time around.

Secrets from the Temple of Inscriptions in Mexico and the Gateway of the Sun at Tiahuanaco, help the Author to identify and locate the Holy Grail, the cup used by Jesus and his Disciples at the Last Supper. He discovers that the Grail actually radiates light, proving that the so-called Arthurian legends are, after all, based on fact.

Finally, the secrets of the Grail are revealed—secrets that affect the destiny of us all.

Other books by Maurice Cotterell

Astrogenetics
The Amazing Lid of Palenque, Vol. 1
The Amazing Lid of Palenque, Vol. 2
The Mayan Prophecies
The Mural of Bonampak
The Mosaic Mask of Palenque
The Supergods
The Tutankhamun Prophecies
The Lost Tomb of Viracocha
The Terracotta Warriors

Jesus, King Arthur, and the Journey of the Grail

THE SECRETS OF THE SUN KINGS

MAURICE COTTERELL



Bear & Company
Rochester, Vermont

THE CELTIC CHRONICLES

Other books by Maurice Cotterell

- Astrogenetics
- The Amazing Lid of Palenque, Vol. 1
- The Amazing Lid of Palenque, Vol. 2
- The Mayan Prophecies
- The Mural of Bonampak
- The Mosaic Mask of Palenque
- The Supergods
- The Tutankhamun Prophecies
- The Lost Tomb of Viracocha
- The Terracotta Warriors

Jesus, King Arthur, and the Journey of the Grail

THE SECRETS OF THE SUN KINGS

MAURICE COTTERELL



Bear & Company
Rochester, Vermont

Other books by the Author

- Astrogenetics
- The Amazing Lid of Palenque Vol. 1
- The Amazing Lid of Palenque Vol. 2
- The Mayan Prophecies
- The Mural of Bonampak
- The Mosaic Mask of Palenque
- The Supergods
- The Tutankhamun Prophecies
- The Lost Tomb of Viracocha
- The Terracotta Warriors

The Celtic Chronicles

The True Story of the Holy Grail



CELTIC
PRESS

Bear & Company
One Park Street
Rochester, Vermont 05767
www.BearandCompanyBooks.com

Bear & Company is a division of Inner Traditions International

Copyright © 2006 by Maurice Cotterell

Originally published in 2006 in Ireland by Celtic Press as *The Celtic Chronicles: The True Story of the Holy Grail*

All rights reserved. No part of this book may be reproduced or utilized in any form or by any means, electronic or mechanical, including photocopying, recording, or by any information storage and retrieval system, without permission in writing from the publisher.

Library of Congress Cataloging-in-Publication Data

Cotterell, Maurice.
Jesus, King Arthur, and the journey of the Grail: the secrets of the sun kings / Maurice Cotterell.

p. cm.
Includes bibliographical references (p.) and index.
ISBN 1-59143-053-4 (pbk.)
1. Grail—Legends—History and criticism. 2. Ireland—Religion. 3. Jesus Christ. 4. Arthur, King. I. Title.

BF1442.G73C68 2006
001.94—dc22

2006007734

Printed and bound in the United States by Lake Book Manufacturing

10 9 8 7 6 5 4 3 2 1

This book was typeset in Palatino

To send correspondence to the author of this book, mail a first-class letter to the author c/o Inner Traditions • Bear & Company, One Park Street, Rochester, VT 05767, and we will forward the communication.

Contents

Acknowledgements	viii
Illustration Credits	ix
1 The Celts	
The Mystery of the Blonde-haired Mummies	1
The Euro-Celtic Heartland	1
The Mystery of the Hallstatt Swastikas	7
The Spiritual Secrets of Venus	11
The Tomb of the King of Hochdorf	14
Celtic Trade	18
Clauberg	29
La Tène	31
The Gundestrup Cauldron	35
The March of the Romans	39
The Druids	46
2 Who Wrote the Bible?	48
The Old Testament	54
The New Testament	54
The Lost Meaning of the Celtic Spiral	66
After the Crucifixion	80
The Appearance of St. Paul	84
Collation of the New Testament	86
Collapse of Roman Rule	87
St. Patrick	91
	92

Copyright © 2006 Maurice Cotterell
www.MauriceCotterell.com

The right of Maurice Cotterell to be identified as the Author of the Work has been asserted by him in accordance with the Copyright, Designs and Patents Act 1988.

First published in 2006
by CELTIC PRESS

10 9 8 7 6 5 4 3 2 1

All rights reserved. No part of this publication may be reproduced, stored in a retrieval system, or transmitted in any form or by any means, without the prior written permission of the publisher, nor be otherwise circulated in any form of binding or cover other than that in which it is published and without a similar condition being imposed on the subsequent purchaser.

Cataloguing in Publication Data is available from the British Library
ISBN 0 9513195 9 0 (Hardback)

Printed and bound in Great Britain by Mackays of Chatham PLC, Chatham, Kent, England

CELTIC PRESS, Timoleague, West Cork, Ireland

Published in the USA and Canada by:
Bear & Company, a Division of Inner Traditions International
1 Park Street, Rochester, Vermont 05767, USA

under the title of:
Jesus, King Arthur, and the Journey of the Grail, the secrets of the Sun Kings

3 The Monasteries	94
Havens of Refuge	94
The Works of Angels	98
Decoding the Celtic Designs—Continuous-line Drawing	104
Decoding the Celtic Knot-work Patterns	106
4 A Land Without a King	114
The Arthurian Legends	114
The Pre-Raphaelites	122
The Secrets of the Tara Brooch	128
The Ardagh Hoard	136
5 The Holy Grail	139
The Ardagh Chalice	139
Construction of the Grail	140
General Description	142
The Secrets of the Foot-Cone	144
The Secrets of the Mesh-mat Panels	148
The Secrets of the Bowl and the Bowl Girdle	152
The Meaning of the Missing Stud	152
The Mystery of the Script	153
The Mystery of the Names	153
The Mystery of the Grammar	153
The Secrets of the Carving	154
The Secrets of the Dragons	158
The Secrets of the Maze-like Pattern	159
Decoding the Maze-like Pattern	160
The Secrets of the Quartz Crystal	163
The Secrets of the Swastika Panels	165
The Secrets of the Yellow Rim and the Nails	168
The Secrets of the Handle Escutcheon Plates	169
The Derrynaflan Hoard	172
The Copycat Monks	177
Conclusion	181
6 The Secret of the Grail	181
The First Picture of God	181
Whom Does the Grail Serve?	185
Appendix One: Decoding the Viracocha Transformer	187
The Secrets of Tiahuanaco	190

Appendix Two: Secrets of the Ancients	202
Why and How They Encoded Their Secrets into Their Treasures	202
Encoding Information Using Pictures	203
Encoding Information Using Numbers	203
How the Soul Gets to Heaven	209
The Mechanism of Soul Transmigration	210
Appendix Three: The Sun as the Feathered Snake	214
Appendix Four: Calculation of the Sunspot Cycle Using Sacred Geometry	219
Notes	224
Bibliography	229
Index	233

CONTENTS

Contents

Acknowledgements	viii
Credits	ix
Introduction	xi
Chapter One: The Celts	1
The Mystery of the Blonde-haired Mummies	1
The Euro-Celtic Heartland	7
The Mystery of the Hallstatt Swastikas	11
The Spiritual Secrets of Venus	14
The Tomb of the King of Hochdorf	18
Celtic Trade	28
Glauberg	30
La Tène	32
The Gundestrup Cauldron	38
The March of the Romans	45
The Druids	47
Chapter Two: Who Wrote the Bible?	56
The Old Testament	56
The New Testament	68
The Lost Meaning of the Celtic Spiral	81
After the Crucifixion	84
The Appearance of St Paul	88
Collation of the New Testament	89
Collapse of Roman Rule	93
St Patrick	94

Acknowledgements

With sincere thanks, as always, to G, and VH; to my wife Ann for her continuing support; to Eduardo Velasquez for German-English translation; to the team at Inner Traditions USA and to the staff of the National Museum of Ireland, Dublin.

viii

Credits

Sources of illustrations and quotations

All illustrations, drawings, artwork and photographs by Maurice Cotterell, except those specified below:

Text Figures

3b, (55) American Museum of Natural History; 18a, 18b, 19, 21a AKG Images; 23a, 23b, 29 National Museum of Ireland; A27 (mask) after Vautier de Nanxe; 34, 35, 37, 38 (part), 62 (part); 52b, 53a Victoria & Albert Museum; 53b, after Augustus Villagra.

Colour Plates

Plate 1a, 1b, 1d Jeffrey Newbury/*Discover Magazine*, vol. 15, no. 4 (April 1994); 1c Prof. He Dexiu; 14a, 14b, 14c Werner Forman Archive; 15 Christies Images Ltd.; 17,18,19 AKG Images; 20a (20c and 21, detail), 20b, 24a, 24b National Museum of Ireland; 21g Wm. MacQuitty Collection.

Quotations

The Chinese Classics vols. I-V, James Legge, University of Hong Kong Press (1960); *Sacred Books of the East* vol. X, Max Muller (trans.) Oxford (1881); *The Popol Vuh*, University of Oklahoma Press (1947); *Holy Bible* (Special Command), Eyre & Spottiswode (1897). *The Geeta*, Swami Shri Purohit, Faber and Faber (1935). *The Annals of Inisfallen*, Dublin Institute for Advanced Studies, Ms Rawlinson B.503, ed. Seán Mac Airt (1988). *Treasures of the National Museum of Ireland*, ed. Wallace & Ragnall Ó

ix

THE CELTIC CHRONICLES

Chapter Three: The Monasteries	96
Havens of Refuge	96
The Works of Angels	100
Decoding the Celtic Designs—Continuous-line drawing	108
Chapter Four: A Land Without A King	116
The Arthurian Legends	116
The Pre-Raphaelites	124
The Secrets of the Tara Brooch	130
The Ardagh Hoard	137
Chapter Five: The Holy Grail	141
The Ardagh Chalice	141
Construction of the Grail	142
General Description	144
The Secrets of the Foot-Cone	147
The Secrets of the mesh-mat Panels	147
The Secrets of the Bowl and Bowl Girdle	149
The Meaning of the missing Stud	153
The Mystery of the Script	153
The Mystery of the Names	155
The Mystery of the Grammer	155
The Secrets of the Carving	155
The Secrets of the Dragons	156
The Secrets of the maze-like pattern	161
Decoding the maze-like pattern	163
The Secrets of the Quartz Crystal	163
The Secrets of the Swastika Panels	165
The Secrets of the Yellow Rim and the Nails	169
The Secrets of the Handle Escutcheon Plates	171
The Derrynaflan Hoard	173
The Copycat Monks	173
Conclusion	178
Chapter Six: The Secret of the Grail	182
The first picture of God	182
Whom does the Grail Serve?	186
Appendix 1: Decoding the Viracocha Transformer	188
The Secrets of Tiahuanaco	191
Appendix 2: Secrets of the Ancients	203
Why and How they Encoded their Secrets	203
into their Treasures	203

CONTENTS

Encoding Information using Pictures	205
Encoding Information using Numbers	205
How the Soul Gets to Heaven	207
The Mechanism of Soul Transmigration	211
Appendix 3: The Sun as the Feathered Snake	215
Appendix 4: Calculation of the Sunspot cycle using Sacred Geometry	220
Bibliography	225
Index	229

vii

Floinn, Gill & Macmillan (2002). *The Treasures of Ireland*, Royal Irish Academy (1983). *Application of Science in Examination of Works of Art*, ed. William J. Young (1970). *Celtic Art*, George Bain, Dover Books (1973). *Hidden Wisdom in the Holy Bible*, vol. 1, G. Hodson, Wheaton, Ill., Theosophical Publishing House. *Bede's Ecclesiastical History of the English People*, ed. B. Colgrave and R. A. S. Mynors (Oxford 1969) IV.4. Letter from Aluin to Einewald, *The Annals of Ulster*, 793.

CHAPTER ONE

The Celts

The Mystery of the Blonde-haired Mummies

When Victor Mair, Professor of Chinese studies at the University of Pennsylvania, and archaeologist J. P. Mallory returned from China, they told their colleagues of what they had seen: perfectly preserved 4,000-year-old mummies, desiccated by dry desert sands. Tall white women with blonde hair, pigtails and tattoos; tall white men with brown beards; tiny white babies with blue eyes; woven fabrics of tartan and bonnets made of soft dyed wool. Everyone laughed. Mallory and Mair must have been mistaken, everyone agreed. Perhaps what they had seen were simply aberrations of the eye from wandering too long in the desert sun.

But a week later when the photographs appeared (plate 1), the laughing stopped and the questions began. What were Caucasians doing in the wastelands of China 4,000 years ago? How did they get there? Where did they get their knowledge of spinning and weaving? What process had preserved the bodies so perfectly? And why had it taken so long for modern man to discover them?

And the speculation began: Could these be the survivors of the legendary Atlantis that Plato says sank to the bottom of the sea 9,000 years before Solon? If so, how did they get from the eastern Mediterranean, the likeliest location of the fabled island, to the Taklamakan Desert of China? And why would they wish to settle there at all? Could the mummies be related to the mysterious tall, blonde, blue-eyed Philistines who came seemingly from nowhere in around

Acknowledgements

With sincere thanks, as always, to G. and VH; to my wife Ann for her continuing support; to Eduardo Velazquez for German-English translation and to the staff of the National Museum of Ireland, Dublin.

Credits

Sources of illustrations and quotations

All illustrations, drawings, art work and photographs by Maurice Cosarek, except those specified below:

Text Figures

Figure 36 (and plate 3b, detail) American Museum of Natural History; 19a, 19b, 20 (22, detail), 21a AKG Images; 23a, 23b, 29 National Museum of Ireland; A27 (mask, and plate 24a, miniatures) after Vautier de Nanxoe; 14, 20, 37, 38 (part) 62 (part) George Bain *Celtic Art—the methods of construction*; 52b, 53a Victoria & Albert Museum; 54b after Augustus Villagra.

Colour Plates

Plate 1a, 1b, 1d Jeffrey Newbury/Discover Magazine, Vol. 15, no. 4 (April 1991); 1c Prof. He Dezu; 14a, 14b, 14c Werner Forman Archive; 16, 17, 19 AKG Images; 19 Christies Images Ltd.; 20a (20c and 21, detail), 20b, 23a, 23b National Museum of Ireland; 21g Wm. MacQuitty Collection.

Citations: *The Chinese Classics* Vols. I-V, James Legge, University of Hong Kong Press (1960); *Sacred Books of the East* Vol. X, Max Muller (trans.) Oxford (1881); *The Popul Vuh*, University of Oklahoma Press (1947); *Holy and Special Commands* Eyra & Spontinwode (1887); *The Certu, Shri Purohit*

1000 BC to attack the Hebrews in Canaan, modern-day Israel? Could they have been the precursors of the legendary Aryans, the blonde-haired, blue-eyed, fair-skinned master race thought to be the genetic precursors of the Germans? Or were they the kin of the Celts,³ the blonde-haired, blue-eyed, tartan-clad seminomadic herders who spread from Germany from around 1000 BC throughout Europe? Or could all of these—thorns as they are in the side of history—owe their lineage to the mummies of Taklamakan?

Little is known of any of these peoples. The Celts, who feature most prominently and whose ancestors survive today, are difficult to define adequately. Attempts have been made to classify them by the language they spoke, but the picture is complex⁴ with insufficient evidence to suggest that continental Celtic derives from a common source.

Attempts have been made to classify them biologically, as a race; a study carried out in 2001 by Professor Bryan Sykes of the Oxford Genetic Atlas Project compared the DNA⁵ of a sample of Celtic Welsh people to an ancient central European Celtic bone sample and showed that Celts in the west of Britain share the same genetic lineage as those in Ireland, whereas the DNA of samples from the east of Britain is more closely related to the DNA of the later Anglo-Saxons⁶ and the Vikings and Normans who came later.

Most historians do not believe that there was just one single influx of Celtic people that invaded the western parts of the British Isles. The consensus seems to be that the modern-day Irish, who describe themselves as Celtic, most likely evolved from several European incursions into the British Isles, the first in around 3113 BC, another in around 1500 BC, and others, later, all from Europe.

It seems that in around 3113 BC a single group of European-main-land migrants split into two, one settling in Wales and England—the builders of Stonehenge, in around 3113 BC—and a second that settled on the east coast of Ireland, the builders of megalithic Newgrange (close to the Neolithic barrows and ring ditches of Tara, northwest of today's Dublin).

'The Irish World Chronicles', a section in *The Annals of Inisfallen* that covers the historical period from the creation of the world to AD 432, says that the Tuatha Dé [Danann] were the mythical masters of

Ireland in around 1500 BC, before the arrival of 'the sons of Míl'.⁷ The Chronicles then follow the flight of Míl from Scythia at some time between 1498 BC and 1029 BC.⁸

Entry No. 35 says that [following a failed attempt to secure the throne for himself] Míl killed Refóir, the son of Némim, and fled into exile taking four ships each of which carried fifteen married couples and a mercenary soldier. The ships make landfall at an island called Taprobane where the exiles rest for three months before embarking on a ninety-day sea voyage that takes them to Egypt. In the eighth year of their stay Míl marries Princess Scotta, the Pharaoh's daughter. The Pharaoh subsequently drowned in the Red Sea.

When Míl and his people found out [that the Pharaoh had died] they set out by sea with the same number as before and with Scotta the Pharaoh's daughter. They landed [again] in Taprobane Island and stayed for a month. After that they voyaged around Scythia near the entrance to the Caspian Sea. Then they anchored in the Caspian Sea for 27 days . . . until Caicher the Druid delivered them. After that they rowed past the promontory of the Rhiphaen Mountain, coming from the north, until they landed at Dacia where they stayed for a month. Caicher the Druid said to them 'until we reach Ireland we shall not halt'. They then rowed . . . and landed in Spain. They found it uninhabited on their arrival and dwelled there for 30 years and it was from it that 'Míl of Spain' was named; and there the two sons of Míl, Eremón and Ír, were born. And they are the two youngest . . .

The 60 married couples and 4 mercenaries set out after that with the sons of Míl and Scotta, Pharaoh's daughter, over sea to Ireland. . . . A great storm arose and parted the ship in which Donn⁹ . . . was separated from the others. He and the crew of his ship were drowned in the sand dunes in the western sea . . . The sons of Míl divided Ireland between them after that, as the historians relate. (*The Annals of Inisfallen*, Trs. Ms Rawlinson B.503, ed. Seán Mac Airt, Dublin Institute for Advanced Studies, 1988)¹⁰

Later incursions into Ireland carried the tall blue-eyed blondes from France and Germany firstly to England and then on to Ireland c. 800 BC. If this is indeed what happened, then it at least explains away the

THE CELTIC CHRONICLES

Swami, Faber and Faber (1935). *The Annals of Inisfallen*, Dublin Institute for Advanced Studies, Ms. Rawlinson B.503, Ed. Seán Mac Airt, (1988). *Treasures of the National Museum of Ireland*, Ed. Wallace & Ragnall Ó Floinn, Gill & Macmillan (2002). *The Treasures of Ireland*, Royal Irish Academy (1983). *Application of Science in Examination of Works of Art*, Ed. William J. Young, (1970). *Celtic Art*, George Bain, Dover Books (1973). *Hidden Wisdom in the Holy Bible*, vol.1, G. Hodson, Wheaton Ill., Theosophical Publishing House. *Bede's Ecclesiastical History of the English People*, Ed. B. Colgrave and R.A.B. Mynors (Oxford 1969) IV. 4. Letter from Aluin to Ethewald, *The Annals of Ulster*, 793.

ubiquitous presence of the blue-eyed ginger-blondes that live along side the shorter black-haired types in Ireland today.

The orthodox view, augmented by the discoveries in the Taklamakan Desert, provides a simplified scheme (figure 1a) suggesting that the blonde-haired tartan-clad Celts first appeared in Chinese Turkestan in around 2000 BC. Commentators agree that they probably migrated north as the Tarim basin fell slowly to desertification. Tombs at the site of Qawrighul, near Loulan, where the 'Beauty of Loulan' (plate 1a) was found, are marked by semi-submerged log posts buried deep into the ground, arranged like massive circular henges in concentric circles with radiating arms, emulating the Sun and its rays—proving on the one hand that trees must have once grown in the region before it became desert and, on the other, that the people of Taklamakan revered the Sun and its rays, as did the Celts, who adopted the solar cross as their symbol (figures 2b and 2d). The surviving seminomads of the Tarim basin could then have migrated to central Europe, moving their cattle and sheep to ever-more fertile pastures northwards and westwards through the grassland steppes of Eurasia. At the same time, another splinter group may have moved westwards (figure 1b) through Sumeria to Turkey, explaining away the Philistine and Aryan enigmas. Having reached central Europe in around 1200 BC, some may have carried the Celtic language southeastwards to Turkey.

The fact is that no one knows for certain who the Celts were or where they came from. And, yet, we all seem to know to whom we are referring when we speak of them.

Later we discover that, colloquially, the Celts shared a common art form; their Druidic priests understood the super-science of the Sun—how it controls behaviour (astrology) and regulates fertility as it spins on its axis every twenty-eight days; they understood how the Sun brings periodic catastrophic destruction to Earth—erasing each civilization in turn from the annals of history; they believed in an after-life and they worshipped the bat god as the god of death and the stag as the god of fertility. They believed in a 'Son of God' who was born through an Immaculate Conception, performed miracles and who—when he died—became Venus, the morning and the evening star, the brightest and purest source of light in the heavens. And like the ancient sun-worshipping Maya of Mexico, and the ancient Peruvians:

The Celtic Highway

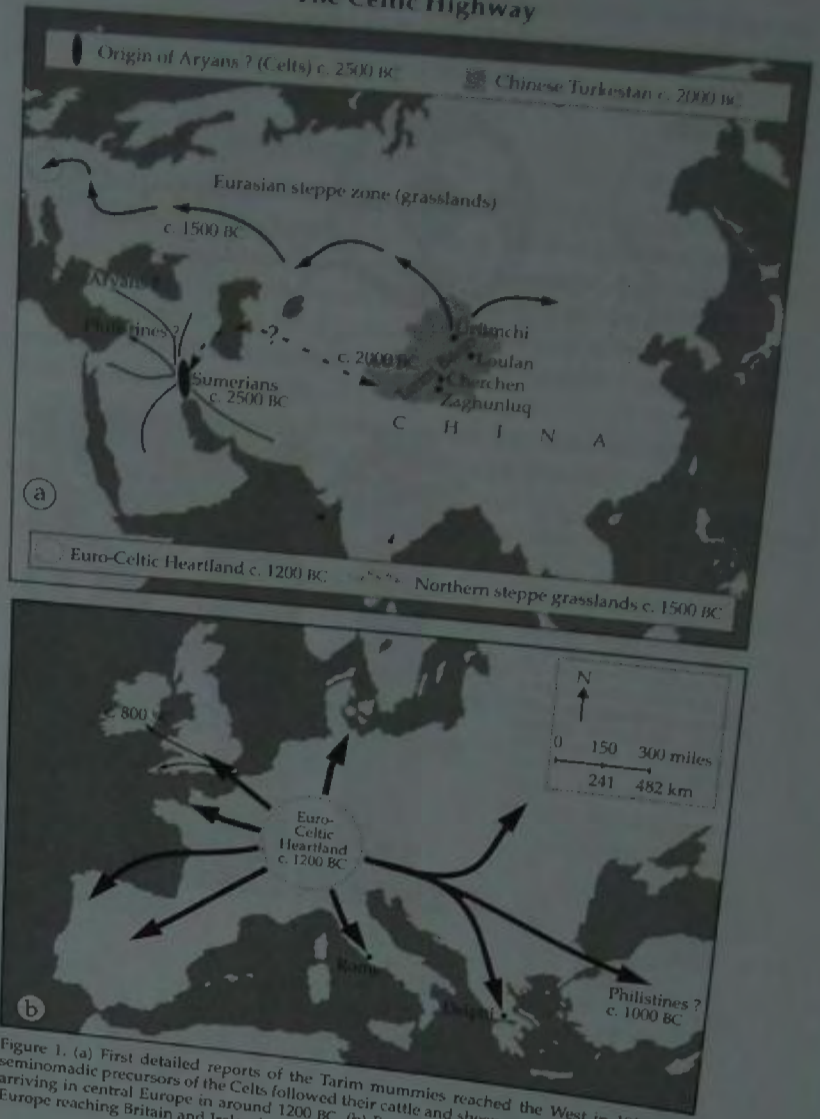

Figure 1. (a) First detailed reports of the Tarim mummies reached the West in 1994. The seminomadic precursors of the Celts followed their cattle and sheep across the fertile steppes arriving in central Europe in around 1200 BC. (b) From around 1000 BC they moved across Europe reaching Britain and Ireland by c. 800 BC.

Introduction

This book is about the Celtic people and the Holy Grail—the Holy cup they treasured, that is now kept safely in the National Museum of Ireland in Dublin alongside Excalibur, the sword of King Arthur.

The Sun, the Cross and the Celts

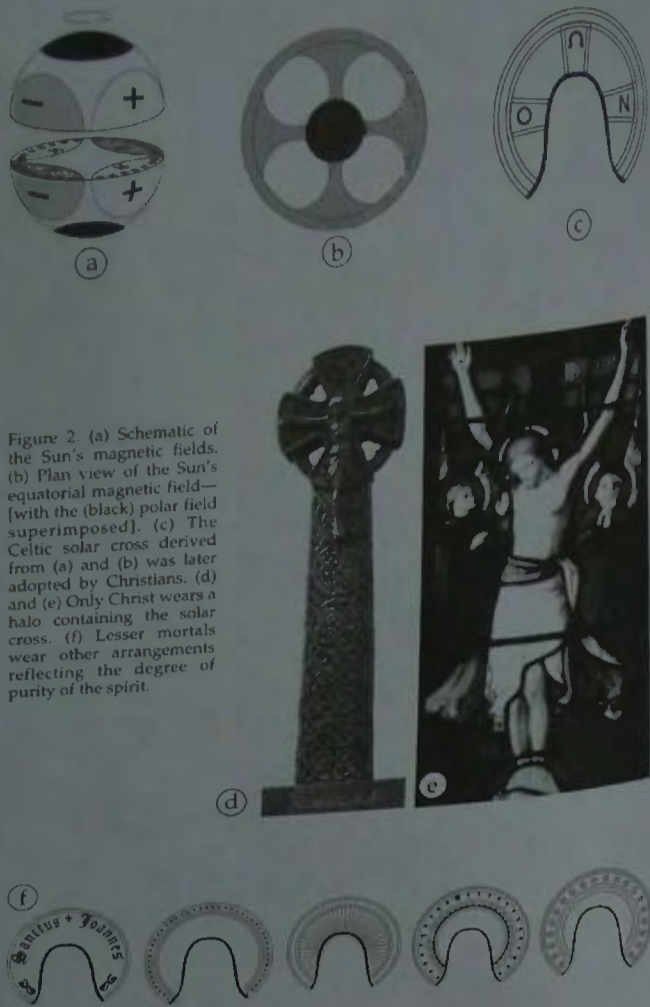

Figure 2. (a) Schematic of the Sun's magnetic fields. (b) Plan view of the Sun's equatorial magnetic field—[with the (black) polar field superimposed]. (c) The Celtic solar cross derived from (a) and (b) was later adopted by Christians. (d) and (e) Only Christ wears a halo containing the solar cross. (f) Lesser mortals wear other arrangements reflecting the degree of purity of the spirit.

Egyptians and Chinese, they encoded their secrets into their treasures for themselves to rediscover in a future incarnation—just in case they failed to make it to Heaven this time around.

The Euro-Celtic Heartland

By around 1000 bc the Celts had settled at the pre-historic salt-mining site of Hallstatt in the Austrian foothills at Salzburg (figure 3).¹¹ The rock salt, sediment of an ancient sea, was important to the Alpine Celts as a source of iodine—used in the prevention of cretinism and goitre in mountain regions; as a meat preservative; and as a flavour enhancer, making it a valuable commodity that could be traded for luxury goods with other landlocked areas.

Mining first began by digging tunnels into the sloping hillsides and then continued deeper into the mountains. The 4,000 metres or so of disused mine shafts today contain a legacy of Celtic industrial activity, including the salt-preserved bodies of dead miners, fragments of woven clothing, leather boots, backpacks and tools.

In 1846 the archaeologist Johann Georg Ramsauer discovered a

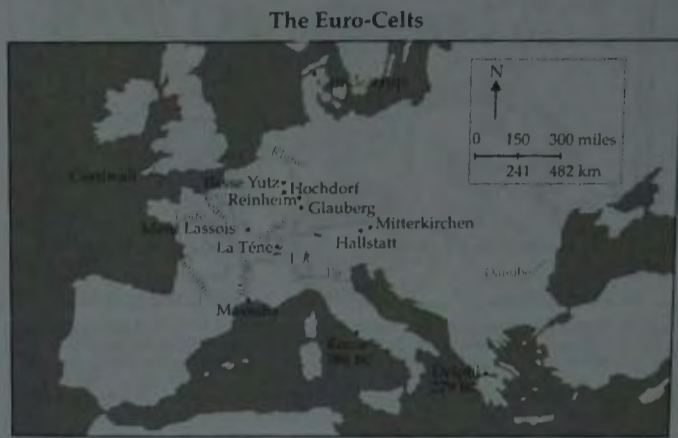

Figure 3.

CHAPTER ONE

The Celts

The Mystery of the Blonde-haired Mum...

Zestril

When Victor Mair, Professor of Chinese studies at the University of Pennsylvania, and archaeologist J. P. Mallory returned from China, they told their colleagues of what they had seen; perfectly preserved 4,000-year-old mummies, desiccated by dry desert sands. Tall white women with blonde hair, pigtailed and tattoos; tall white men with brown beards, tiny white babies with blue eyes; woven fabrics of tartan and bonnets made of soft dyed wool. Everyone laughed. Mallory and Mair must have been mistaken, everyone agreed. Perhaps what they had seen were simply aberrations of the eye from wandering too long in the desert sun.

But a week later when the photographs appeared (plate 1) the laughing stopped and the questions began. What were Caucasians doing in the wastelands of China 4,000 years ago? How did they get there? Where did they get their knowledge of spinning and weaving? What process had preserved the bodies so perfectly? And why had it taken so long for modern man to discover them?

And the speculation began: Could these be the survivors of the legendary Atlantis that Plato says 'sank to the bottom of the sea 9,000 years before Solon'. If so, how did they get from the eastern Mediterranean, the likeliest location of the fabled island, to the Taklamakan desert of China? And why would they wish to settle there at all? Could the mum-

The Sun, the Cross and the Celts

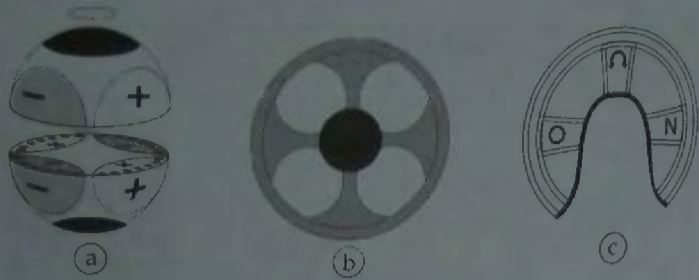
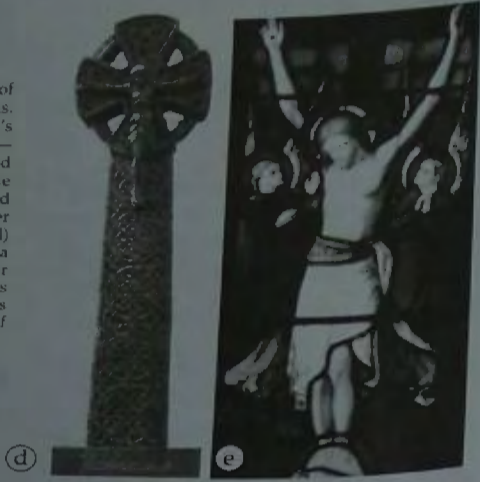

Figure 2. (a) Schematic of the Sun's magnetic fields. (b) Plan view of the Sun's equatorial magnetic field—[with the (black) polar field superimposed]. (c) The Celtic solar cross derived from (a) and (b) was later adopted by Christians. (d) and (e) Only Christ wears a halo containing the solar cross. (f) Lesser mortals wear other arrangements reflecting the degree of purity of the spirit.



Egyptians and Chinese, they encoded their secrets into their treasures for themselves to rediscover in a future incarnation—just in case they failed to make it to Heaven this time around.

The Euro-Celtic Heartland

By around 1000 BC the Celts had settled at the pre-historic salt-mining site of Hallstatt in the Austrian foothills at Salzburg (figure 3).¹¹ The rock salt, sediment of an ancient sea, was important to the Alpine Celts as a source of iodine—used in the prevention of cretinism and goitre in mountain regions; as a meat preservative; and as a flavour enhancer, making it a valuable commodity that could be traded for luxury goods with other landlocked areas.

Mining first began by digging tunnels into the sloping hillsides and then continued deeper into the mountains. The 4,000 metres or so of disused mine shafts today contain a legacy of Celtic industrial activity, including the salt-preserved bodies of dead miners, fragments of woven clothing, leather boots, backpacks and tools.

In 1846 the archaeologist Johann Georg Ramsauer discovered a

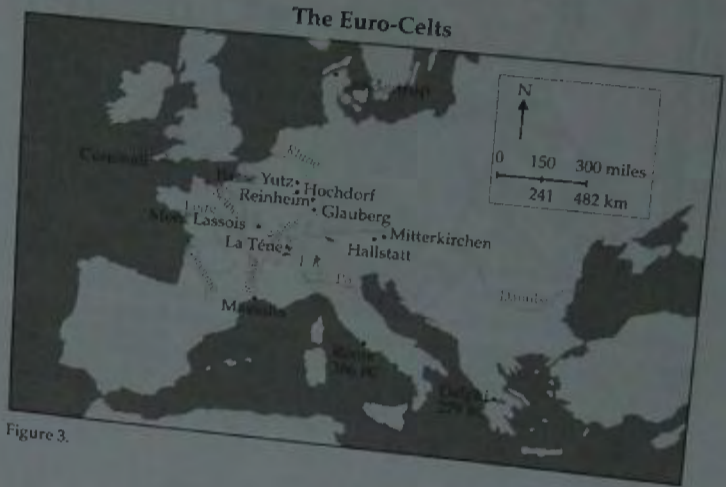

Figure 3.

CHAPTER ONE

The Celts

Zestril

The Mystery of the Blonde-haired Mummies

When Victor Mair, Professor of Chinese studies at the University of Pennsylvania, and archaeologist J. P. Mallory returned from China, they told their colleagues of what they had seen: perfectly preserved 4,000-year-old mummies, desiccated by dry desert sands. Tall white women with blonde hair, pigtailed and tattoos; tall white men with brown beards, tiny white babies with blue eyes; woven fabrics of tartan and bonnets made of soft dyed wool. Everyone laughed. Mallory and Mair must have been mistaken, everyone agreed. Perhaps what they had seen were simply aberrations of the eye from wandering too long in the desert sun.

But a week later when the photographs appeared (plate 1) the laughing stopped and the questions began. What were Caucasians doing in the wastelands of China 4,000 years ago? How did they get there? Where did they get their knowledge of spinning and weaving? What process had preserved the bodies so perfectly? And why had it taken so long for modern man to discover them?

And the speculation began: Could these be the survivors of the legendary Atlantis that Plato says sank to the bottom of the sea 9,000 years before Solon? If so, how did they get from the eastern Mediterranean, the likeliest location of the fabled island, to the Taklamakan desert of China? And why would they wish to settle there at all? Could the mum-

burial ground near the mines containing the bodies of 1,045 of the Hallstatt elite. Excavators unearthed a wealth of Celtic treasures including bronze urns decorated with spoked-wheel discs and birds [both of which are known Celtic solar symbols], bronze daggers and swords.

The style and decoration of artefacts found in the cemetery is distinctive, and similar-style artefacts have been found scattered across Europe.

This initial appearance of Euro-Celtic culture is named the Hallstatt period. Archaeologists later began to notice the emergence of differences in the style and content of grave goods and divided the period into four phases: Hallstatt A (c. 1200–1000 BC); B (c. 1000–750 BC); C (c. 750–600 BC) and D (c. 600–480 BC). For example, early Hallstatt C discoveries include bronze and iron swords, whereas in the later period, D, daggers were more plentiful.

One sword scabbard from the Hallstatt cemetery is engraved with ostensible battle scenes showing warriors, some marching in formation, some on horseback carrying spears and other scenes that are duplicated—as though to emphasise their importance—showing two soldiers holding a wheel (figure 4).

The scene tells us a lot about the Hallsatt Celts. The central circle represents the Sun. The star inside the circle shows that the Celts were acutely aware that our Sun is, in the scientific sense, a star. Two circles, one above and one below the Sun symbol, represent the twin-star (planet) Venus in its various manifestations as the 'morning star' and the 'evening star' (figure 5) which for 292 days (viewed from the moving Earth) can only be seen in the dark morning sky, before the Sun rises. During the next 292 days Venus can only be seen after sunset, in

The Carving on the Hallstatt Scabbard



Figure 4. Detail of the engraving on the scabbard [from tomb number 994 in the Hallstatt cemetery c. 600 BC]. The centre circle represents the Sun. The top and bottom circles represent the planet Venus, as the morning star and the evening star. The characters either side represent the twins, a metaphor used by all of the sun-worshipping civilizations to represent the twin-star (planet) Venus (figure 5). The borders contain an interlaced vertical reverse-swastika pattern. The maze-like pattern that circumscribes the centre circle contains encoded secret information.

The Twin-star (planet) Venus

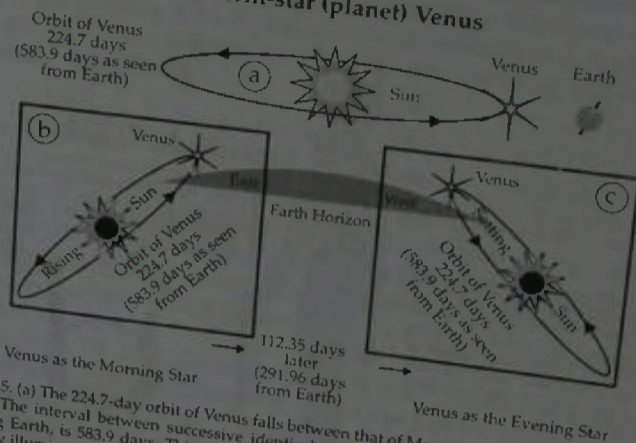

Figure 5. (a) The 224.7-day orbit of Venus falls between that of Mercury (not shown here) and Earth. The interval between successive identical appearances of Venus, as seen from the moving Earth, is 583.9 days. This means that Venus, in the position shown in (b), appears brightly illuminated in the dark morning sky. In position (c) the Sun sets before Venus which shines brightly in the darkening evening sky. Because of this, and because Venus is the brightest heavenly body, she is referred to as the morning star and the evening star, the twin-star.

mies be related to the mysterious tall, blonde, blue-eyed Philistines who came seemingly from nowhere in around 1000 BC to attack the Hebrews in Canaan, modern-day Israel? Could they have been the precursors of the legendary Aryans, the blonde-haired, blue-eyed, fair-skinned master race thought to be the genetic precursors of the Germans? Or were they the kin of the Celts², the blonde-haired blue-eyed tartan clad seminomadic herders who spread from Germany from around 1000 BC throughout Europe? Or, could all of these—thorns as they are in the side of history—owe their lineage to the mummies of Taklamakan?

Little is known of any of these peoples. The Celts, who feature most prominently and whose ancestors survive today, are difficult to define adequately. Attempts have been made to classify them by the language they spoke, but the picture is complex³ with insufficient evidence to suggest that Continental Celtic derives from a common source.

Attempts have been made to classify them biologically, as a race: a study carried out in 2001 by Professor Bryan Sykes of the Oxford Genetic Atlas Project compared the DNA⁴ of a sample of Celtic Welsh people to an ancient central European Celtic bone sample and showed that Celts in the west of Britain share the same genetic lineage as those in Ireland, whereas the DNA of samples from the east of Britain is more closely related to the DNA of the later Anglo-Saxons⁵ and the Vikings and Normans who came later.

Most historians do not believe that there was just one single influx of Celtic people that invaded the western parts of the British Isles. The consensus seems to be that the modern-day Irish, who describe themselves as Celtic, most likely evolved from several European incursions into the British Isles, the first in around 3113 BC another, in around 1500 BC, and others, later, all from Europe.

It seems that in around 3113 BC a single group of European-mainland migrants split into two, one settling in Wales and England—the builders of Stonehenge, in around 3113 BC—and a second that settled on the east coast of Ireland, the builders of megalithic Newgrange (close to the Neolithic barrows and ring ditches of Tara, north-west of today's Dublin).

'The Irish World Chronicles', a section in *The Annals of Inisfallen*⁶ that covers the historical period from the creation of the world to AD 432.

says that the Tuatha Dé [Danann] were the mythical masters of Ireland in around 1500 BC, before the arrival of 'the sons of Mil'. The Chronicles then follow the flight of Mil from Scythia⁸ at some time between 1498 BC to 1029 BC.

Entry No. 35 says that [following a failed attempt to secure the throne for himself] Mil killed Reflóir, the son of Némim and fled into exile taking four ships each of which carried 15 married couples and a mercenary soldier. The ships make landfall at an island called Taprobane where the exiles rest for three months before embarking on a 90-day sea voyage that takes them to Egypt. In the eighth year of their stay Mil married Princess Scotta, the Pharaoh's daughter. The Pharaoh subsequently drowned in the Red Sea:

When Mil and his people found out [that the Pharaoh had died] they set out by sea with the same number as before and with Scotta the Pharaoh's daughter. They landed [again] in Taprobane Island and stayed for a month. After that they voyaged around Scythia near the entrance to the Caspian Sea. Then they anchored in the Caspian Sea for 27 days...until Caicher the Druid delivered them. After that they rowed past the promontory of the Ríphaen Mountain, coming from the north, until they landed at Dacia where they stayed for a month. Caicher the Druid said to them 'until we reach Ireland we shall not halt'. They then rowed...and landed in Spain. They found it uninhabited on their arrival and dwelled there for 30 years and it was from it that 'Mil of Spain' was named; and there the two sons of Mil, Éremon and Ír, were born. And they are the two youngest...

The 60 married couples and four mercenaries set out after that with the sons of Mil and Scotta, Pharaoh's daughter, over sea to Ireland... A great storm arose and parted the ship in which Donn⁹... was separated from the others. He and the crew of his ship were drowned in the sand dunes in the western sea... The sons of Mil divided Ireland between them after that, as the historians relate' (*The Annals of Inisfallen*, Trs. Ms Rawlinson B 503, Ed. Sean Mac Airt, Dublin Institute for Advanced Studies, 1988)¹⁰.

Later incursions into Ireland carried the tall blue-eyed blondes from

the dark evening sky. Because it is the brightest and purest source of light in the sky, it was associated with love and purity of spirit by sun-worshipping civilizations. In the carving the two soldiers, positioned either side of the Sun, represent 'the twins', not only as the twin-star but also as a mirror image of each other. Whenever the ancients referred to the mirror image, they were referring to the soul, the mirror image of the body (figure 6).

The borders of the scabbard carving contain a vertical string of interlaced swastikas, a shape which is known to have been used by ancient civilizations as a solar symbol because it is derived from the pattern of the radiating solar wind (figure 7). This means that the Celts of Hallstatt must have known, as early as 600 BC, that the Sun spins on its axis and showers positively charged particles [the nucleus of the hydrogen atom] and negatively charged particles [electrons] towards the Earth. And they must have known about the 'sectored structure' of the radiating solar wind—how it changes alternately from positive to negative every seven days, in concordance with the underlying

The Body, the Soul and the Sun

Figure 6. The ancient sun-worshipping Egyptians also believed that the soul was the mirror image of the body (that the left is the mirror image of the right) and that the Sun (God) separates the body from the soul.

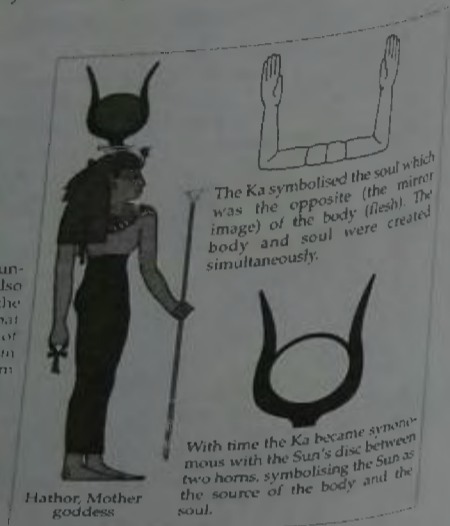

magnetic structure of the Sun—facts only recently revealed to modern man, in 1962, by data received from the Mariner II spacecraft.

The swastika from ancient times evolved as a stylised squared-off version of the solar wind radiation pattern, rather than a facsimile of itself, because the 'square' was the mark of the educated and virtuous man. *The Book of Great Learning*, one of the great Chinese Classics from the school of the philosopher Confucius [d. 479 BC], explains the golden rule (referred to as the measuring square): 'a ruler should treat others as he would have others treat himself'. This sets out the ground rules for a relationship between two parties, as a measuring square sets into stone the relationship between two sides, bearing a close relationship to the Christian ethos that appeared much later.

The astute reader may have noticed that the swastikas in the Hallstatt scabbard carving borders are in fact reversed swastikas, rotating clockwise instead of, more correctly, counterclockwise, like the solar wind water-sprinkler pattern detected by Mariner II (figure 7b). Which means, surely (to the sceptic), that the Celts who carved the picture on the scabbard in fact knew nothing of the solar wind, nothing of the meaning of the square and nothing of astronomy. But these people were much cleverer than that—as were the Maya, Egyptians, Peruvians and Chinese.

The Mystery of the Hallstatt Swastikas

As the Sun spins on its axis every twenty-eight days, the showering positive and negative electrical particles collide with the Van Allen belts (figure 8b), the protective magnetic fields that encircle the Earth. Caught in the belts, the particles spiral between north pole and south pole every second, causing the Earth's magnetic field to vary at ground level.

In 1989, Dr. Ross Aidez, the White House chief medical advisor under the Reagan administration, discovered that the brains of rats, pigeons and guinea-pigs produce varying amounts of the timing hormone melatonin when bombarded by varying amounts of modulated magnetic fields. Melatonin stimulates the pituitary gland in the human brain, which in turn affects the production of the luteinizing hormone and the follicle-stimulating hormone. These in turn regulate

The Celtic Highway

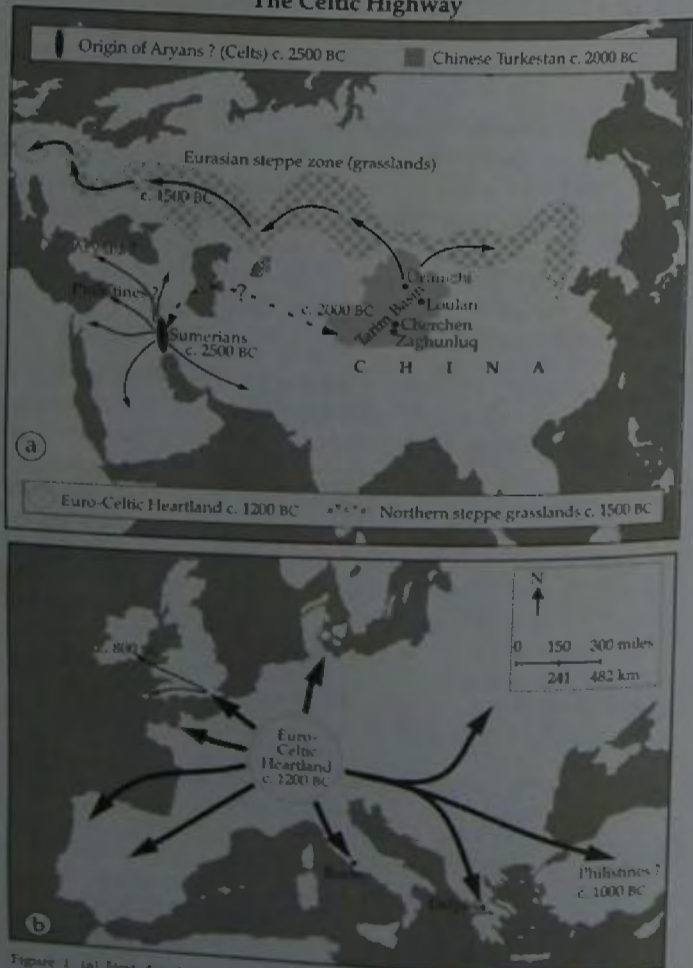

Figure 1. (a) First detailed reports of the tarim mummies reached the West in 1994. The seminomadic precursors of the Celts followed their cattle and sheep across the fertile steppes arriving in central Europe in around 1200 BC. (b) From around 1000 BC they moved across Europe reaching Britain and Ireland by c. 800 BC.

France and Germany firstly to England and then on to Ireland c. 800 BC. If this is indeed what happened then it at least explains-away the ubiquitous presence of the blue-eyed ginger-blondes that live alongside the shorter black-haired types in Ireland today.

The orthodox view, augmented by the discoveries in the Taklamakan desert, provides a simplified scheme (figure 1a) suggesting that the blonde-haired tartan-clad Celts first appeared in Chinese Turkestan in around 2000 BC. Commentators agree that they probably migrated north as the Tarim basin fell slowly to desertification. Tombs at the site of Qawrighul, near Loulan, where the beauty of Loulan (plate 1a) was found, are marked by semi-submerged log posts buried deep into the ground, arranged like massive circular henges in concentric circles with radiating arms, emulating the Sun and its rays—proving on the one hand that trees must have once grown in the region before it became desert and, on the other, that the people of Taklamakan revered the Sun and its rays, as did the Celts who adopted the solar cross as their symbol (figures 2b and 2d). The surviving seminomads of the Tarim Basin could then have migrated to central Europe, moving their cattle and sheep to ever more fertile pastures northwards and westwards through the grassland steppes of Eurasia. At the same time, another splinter group may have moved westwards (Figure 1b) through Sumeria to Turkey, explaining-away the Phillistine and Aryan enigmas. Having reached central Europe in around 1200 BC some may have carried the Celtic language south-eastwards to Turkey.

The fact is that no one knows for certain who the Celts were or where they came from. And, yet, we all seem to know to whom we are referring when we speak of them.

Later we discover that, colloquially, the Celts shared a common art form, their Druidic priests understood the super-science of the Sun—how it controls behaviour (astrology) and regulates fertility as it spins on its axis every 28 days; they understood how the Sun brings periodic catastrophic destruction to Earth—erasing each civilization in turn from the annals of history; they believed in an afterlife and they worshipped the Bad God, as the God of Death and the stag, as the God of Fertility. They believed in a 'Son of God' who was born through an Immaculate Conception, performed miracles and who—when he died—became Venus.

the dark evening sky. Because it is the brightest and purest source of light in the sky, it was associated with love and purity of spirit by sun-worshipping civilizations. In the carving the two soldiers, positioned either side of the Sun, represent 'the twins', not only as the twin-star but also as a mirror image of each other. Whenever the ancients referred to the mirror image, they were referring to the soul, the mirror image of the body (figure 6).

The borders of the scabbard carving contain a vertical string of interlaced swastikas, a shape which is known to have been used by ancient civilizations as a solar symbol because it is derived from the pattern of the radiating solar wind (figure 7). This means that the Celts of Hallstatt must have known, as early as 600 BC, that the Sun spins on its axis and showers positively charged particles [the nucleus of the hydrogen atom] and negatively charged particles [electrons] towards the Earth. And they must have known about the 'sectored structure' of the radiating solar wind—how it changes alternately from positive to negative every seven days, in concordance with the underlying

The Body, the Soul and the Sun

Figure 6. The ancient sun-worshipping Egyptians also believed that the soul was the mirror image of the body [that the left is the mirror image of the right] and that the Sun (God) separates the body from the soul.

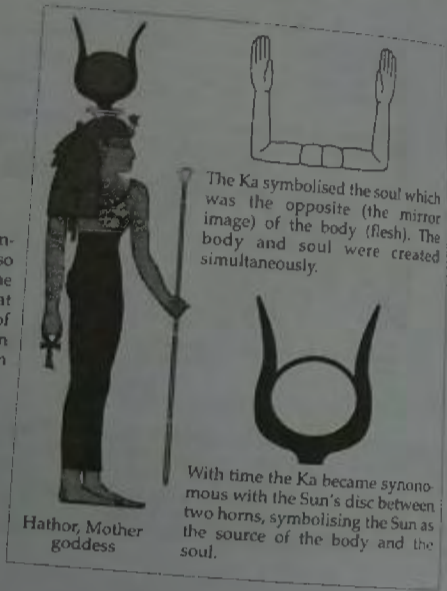

magnetic structure of the Sun—facts only recently revealed to modern man, in 1962, by data received from the Mariner II spacecraft.

The swastika from ancient times evolved as a stylised squared-off version of the solar wind radiation pattern, rather than a facsimile of itself, because the 'square' was the mark of the educated and virtuous man. *The Book of Great Learning*, one of the great Chinese Classics from the school of the philosopher Confucius [d. 479 BC], explains the golden rule (referred to as the measuring square): 'a ruler should treat others as he would have others treat himself'. This sets out the ground rules for a relationship between two parties, as a measuring square sets into stone the relationship between two sides, bearing a close relationship to the Christian ethos that appeared much later.

The astute reader may have noticed that the swastikas in the Hallstatt scabbard carving borders are in fact reversed swastikas, rotating clockwise instead of, more correctly, counterclockwise, like the solar wind water-sprinkler pattern detected by Mariner II (figure 7b). Which means, surely (to the sceptic), that the Celts who carved the picture on the scabbard in fact knew nothing of the solar wind, nothing of the meaning of the square and nothing of astronomy. But these people were much cleverer than that—as were the Maya, Egyptians, Peruvians and Chinese.

The Mystery of the Hallstatt Swastikas

As the Sun spins on its axis every twenty-eight days, the showering positive and negative electrical particles collide with the Van Allen belts (figure 8b), the protective magnetic fields that encircle the Earth. Caught in the belts, the particles spiral between north pole and south pole every second, causing the Earth's magnetic field to vary at ground level.

In 1989, Dr. Ross Aidey, the White House chief medical advisor under the Reagan administration, discovered that the brains of rats, pigeons and guinea-pigs produce varying amounts of the timing hormone melatonin when bombarded by varying amounts of modulated magnetic fields. Melatonin stimulates the pituitary gland in the human brain, which in turn affects the production of the luteinizing hormone and the follicle-stimulating hormone. These in turn regulate

The Celtic Highway

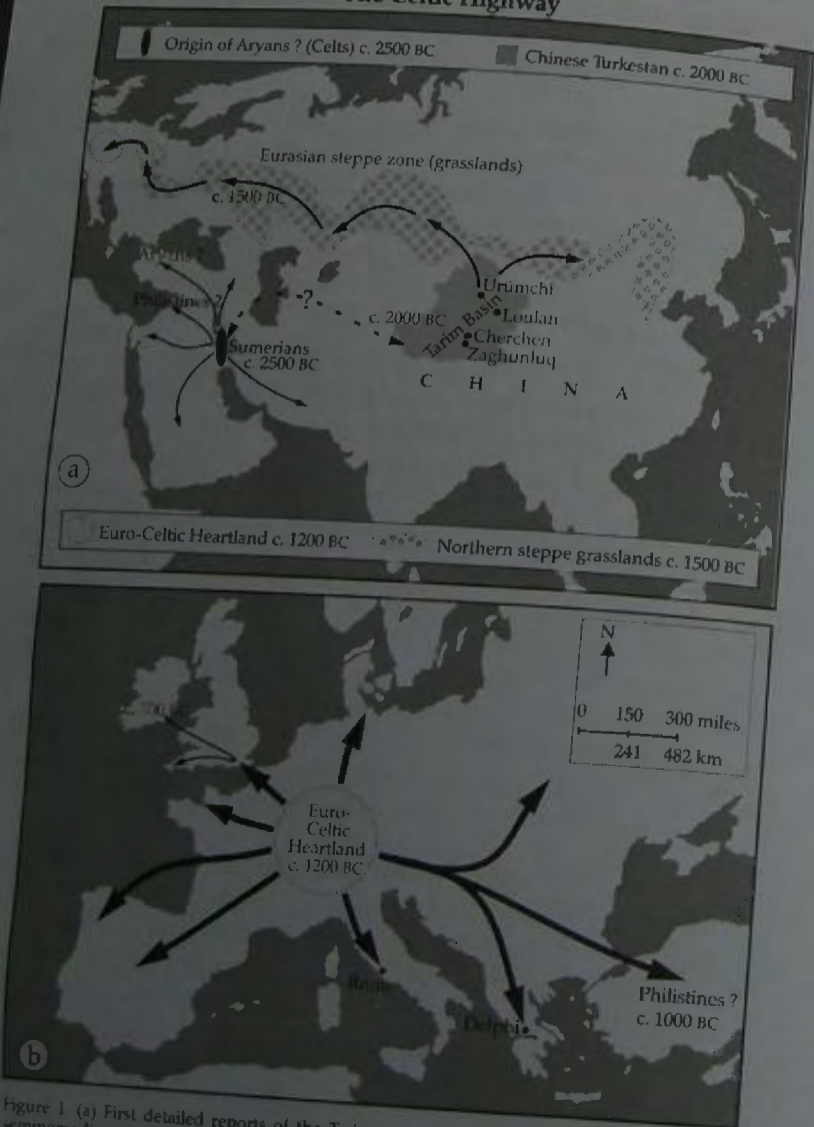

Figure 1. (a) First detailed reports of the Tarim mummies reached the West in 1994. The seminomadic precursors of the Celts followed their cattle and sheep across the fertile steppes arriving in central Europe in around 1200 BC. (b) From around 1000 BC they moved across Europe reaching Britain and Ireland by c. 800 BC.

France and Germany firstly to England and then on to Ireland c. 800 BC. If this is indeed what happened then it at least explains-away the ubiquitous presence of the blue-eyed ginger-blondes that live alongside the shorter black-haired types in Ireland today.

The orthodox view, augmented by the discoveries in the Taklamakan desert, provides a simplified scheme (figure 1a) suggesting that the blonde-haired tartan-clad Celts first appeared in Chinese Turkestan in around 2000 BC. Commentators agree that they probably migrated north as the Tarim basin fell slowly to desertification. Tombs at the site of Qawrighul, near Loulan, where the beauty of Loulan (plate 1a) was found, are marked by semi-submerged log posts buried deep into the ground, arranged like massive circular henges in concentric circles with radiating arms, emulating the Sun and its rays—proving on the one hand that trees must have once grown in the region before it became desert and, on the other, that the people of Taklamakan revered the Sun and its rays, as did the Celts who adopted the solar cross as their symbol (figures 2b and 2d). The surviving seminomads of the Tarim Basin could then have migrated to central Europe, moving their cattle and sheep to ever-more fertile pastures northwards and westwards through the grassland steppes of Eurasia. At the same time, another splinter group may have moved westwards (Figure 1b) through Sumeria to Turkey, explaining-away the Philistine and Aryan enigmas. Having reached central Europe in around 1200 BC some may have carried the Celtic language south-eastwards to Turkey.

The fact is that no one knows for certain who the Celts were or where they came from. And, yet, we all seem to know to whom we are referring when we speak of them.

Later we discover that, colloquially, the Celts shared a common art form: their Druidic priests understood the super-science of the Sun—how it controls behaviour (astrology) and regulates fertility as it spins on its axis every 28 days; they understood how the Sun brings periodic catastrophic destruction to Earth—erasing each civilization in turn from the annals of history; they believed in an afterlife and they worshipped the Bat God, as the God of Death and the stag, as the God of Fertility. They believed in a 'Son of God' who was born through an Immaculate Conception, performed miracles and who—when he died—became Venus,

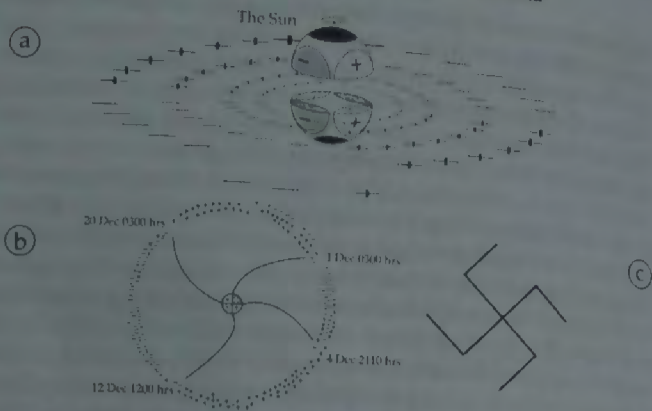

Figure 7. (a) The Sun radiates charged particles (the solar wind) and showers them towards Earth, like a water sprinkler. (b) The sectorized structure of the solar wind was first detected by the Mariner II spacecraft in 1962 and plotted by IMP1 (Interplanetary spacecraft I) in 1963. (c) The swastika represents a schematic of the solar wind pattern and was worshipped by many ancient sun-worshipping civilizations.

How the 28-day Spinning Sun Regulates Menstruation in Females

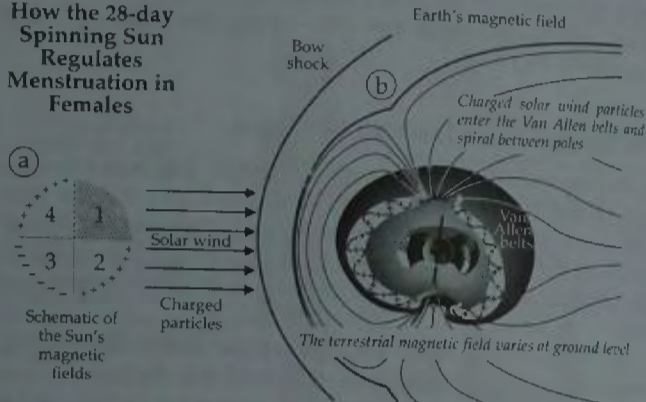

Figure 8. (a) The Sun spins on its axis and radiates charged particles to Earth. (b) The resulting varying magnetic field (at ground level) affects the manufacture of DNA in humans at conception, causing four types of genetic mutations, three times every year, resulting in twelve different types of personality (sun-sign Astrology). It later affects the human brain, causing variations in the production of the timing hormone melatonin every twenty-eight days causing variations in the production of the fertility hormones oestrogen and progesterone every twenty-eight days.

the production of the fertility hormones oestrogen and progesterone in females.¹² So as the Sun spins every twenty-eight days, it showers charged particles to the Earth which regulate the menstrual function in females every twenty-eight days, which explains why the ancient sun-worshipping civilizations worshipped the Sun as the god of fertility.

The spinning Sun also gives rise to magnetic cycles on the Sun's surface, causing the Sun's magnetic field to shift from a northeasterly direction to a southeasterly direction every few thousand years [the calculations are complex and non-periodic]. This magnetic twist has the effect of flipping the planets in our solar system upside down in their orbits. Clearly those nearest to the Sun will be affected most; the stronger the magnetic shift the stronger the effect will reach out into space and the more planets will be affected. Examination of historical solar magnetic activity reveals that a magnetic shift occurred in 3113 BC causing Venus to flip upside down on its axis.¹³

The 1950s writer, historian and scientist Immanuel Velikovsky believed that this 'birth of Venus' had been recorded the world over. In *Worlds in Collision* he wrote:

In Greece, the goddess who suddenly appeared in the sky was Pallas Athene. She sprang from the head of Zeus-Jupiter. To the Chinese, Venus spanned the heavens, rivalling the Sun in brightness. 'The brilliant light of Venus', noted one ancient rabbinical record 'blazes from [one] end of the cosmos to the other'. (Immanuel Velikovsky, *Worlds in Collision*, Book Club Associates, 1973)

Clearly, the Earth, which is farther from the Sun than Venus, and less susceptible to topple on its axis for a given magnetic field strength, did not topple in 3113 BC.

Orthodox archaeologists have always been perplexed as to why Mayan calendrical inscriptions all refer back to a starting date in 3113 BC, because the Maya, civilisation did not appear in Mexico prior to the Teotihuacan period of around AD 100.

The Maya were master astronomers and knew—as we now know—that the Sun's radiation affects fertility on Earth, which is why they worshipped the Sun as the god of fertility. Because they knew just how important the Sun's radiation was to life on Earth, they monitored the Sun's radiation patterns, knowing that the Sun would fail their

The Sun, the Cross and the Celts

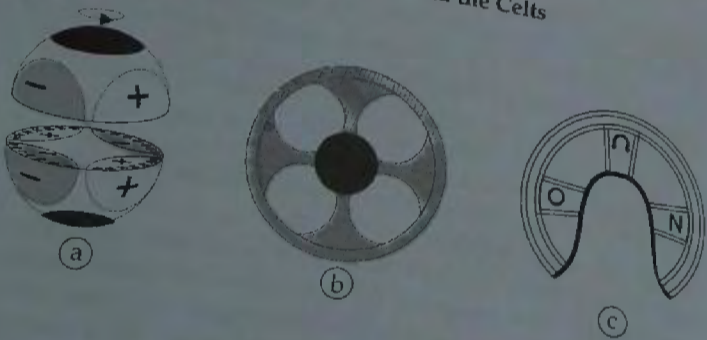
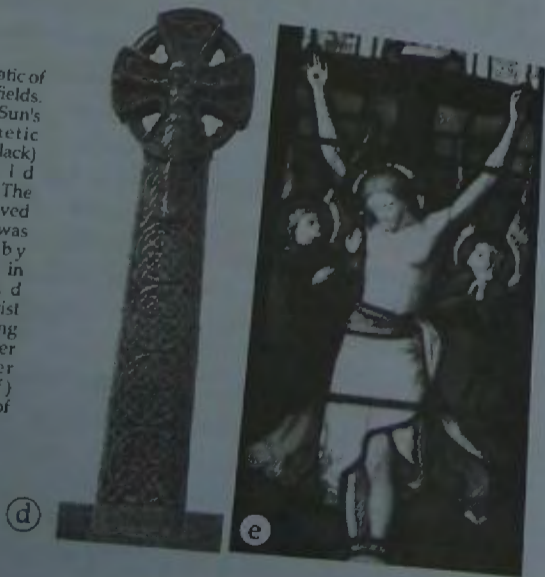

Figure 2. (a) Schematic of the Sun's magnetic fields. (b) Plan view of the Sun's equatorial magnetic field—with the (black) polar field superimposed. (c) The Celtic solar-cross derived from (a) and (b) and was later adopted by Christians and used in the halo of Christ (c, d and e). Only Christ wears a halo containing the solar-cross, lesser mortals wear other arrangements (f) reflecting the degree of purity of the spirit.



the morning and the evening star, the brightest and purest source of light in the heavens. And like the ancient sun worshipping Maya of Mexico, the ancient Peruvians, Egyptians and Chinese, they encoded their secrets into their treasures for themselves to rediscover in a future incarnation—just in case they failed to make it to Heaven, this time around.

The Euro-Celtic Heartland

By around 1000 BC the Celts had settled at the pre-historic salt-mining site of Hallstatt¹¹ in the Austrian foothills at Salzburg (figure 3). The rock salt, sediment of an ancient sea, was important to the Alpine Celts as a source of iodine—used in the prevention of cretinism and goitre in mountain regions; as a meat preservative, and as a flavour enhancer, making it a valuable commodity that could be traded for luxury goods with other land-locked areas.

Mining first began by digging tunnels into the sloping hillsides and then continued deeper into the mountains. The 4,000 metres or so of disused mine-shafts today contain a legacy of Celtic industrial activity, including the salt-preserved bodies of dead miners, fragments of woven clothing, leather boots, backpacks and tools.

In 1846 the archaeologist Johann Georg Ramsauer discovered a burial ground near the mines containing the bodies of 1,045 of the Hallstatt elite. Excavators unearthed a wealth of Celtic treasures including bronze urns decorated with spoked-wheel discs and birds [both of which are known Celtic solar symbols], bronze daggers and swords.

The style and decoration of artefacts found in the cemetery is distinctive and similar style artefacts have been found scattered across Europe.

This initial appearance of Euro-Celtic culture is named the Hallstatt period. Archaeologists later began to notice the emergence of differences in the style and content of grave goods and divided the period into four phases; Hallstatt A (c. 1200–1000 BC); B (c. 1000–750 BC); C (c. 750–600 BC) and D (c. 600–480 BC). For example, early Hallstatt C discoveries include bronze and iron swords whereas in the later period, D, daggers were more plentiful.

One sword scabbard from the Hallstatt cemetery is engraved with ostensible battle scenes showing warriors, some marching in formation.

fertility needs 1,366,040 days after the solar magnetic flip that occurred on the 10th August 3113 BC. In AD 627, 1,366,040 days after the start of their calendar, the Maya began to die, just as they had predicted. For the next 187 years the Sun failed their fertility needs: fewer babies were born; at the same time an increase in solar X-rays, which affected equatorial regions more than other areas,¹⁴ caused an increase in spontaneous foetal abortion and miscarriage throughout Mexico. These events coincided with a solar-inspired mini ice age. Less rain fell globally, but equatorial regions that were less able to cope suffered disproportionately to their neighbours in the north and south from drought, crop failure and famine. It was the end for the Maya.

The Maya encoded the important time interval of 1,366,040 days into one of their treasures, the sun shield of Monte Alban (plate 2a). They also, enigmatically, worshipped a number very close to this, the number 1,366,560, which they referred to as the 'Birth of Venus'. The Dresden Codex, one of the ancient Mayan bark books, records that the end of the world, for them, would come after 2,340 revolutions of Venus [2,340 x 584], 1,366,560 days after their calendar began in 3113 BC, meaning that they expected Venus to tilt upside down again in around AD 627.

This means that the swastikas on the Hallstatt scabbard are not drawn incorrectly. The carving is, more than anything, concerned with the planet Venus, which was flipped upside down in 3113 BC by a solar magnetic twist. So Venus now spins on its axis in the opposite direction to the axial rotation of all of the other planets in our system. From Venus, the Sun spins on its axis, clockwise, not anticlockwise. The stylised swastika on the Hallsatt scabbard explicitly recognises this by using a reversed (clockwise) swastika, rather than a regular one. Thus the Celts were not so careless after all. But why were the Celts, like the Maya, constantly drawing our attention to Venus?

The Spiritual Secrets of Venus

In 1989, while working at Cranfield University, I calculated the duration of magnetic reversals on the Sun. Using the university's massive computer I determined the figure of 1,366,040 days—the same as the number on the sun shield of Monte Alban, slightly less than the Mayan

Birth of Venus number of 1,366,560 days. So why did the Maya, who were aware of the true figure, go to such lengths to refer to the incorrect figure of 1,366,560 days as the Birth of Venus? Was it simply to enable them to track the cycle, knowing that Venus would flip again during the 2,340th Venus revolution as I had initially conjectured?

In 1997 (in *The Supergods*) I showed that many of the world's religious leaders shared much in common;¹⁵ legend says that when Krishna (whose name means 'the anointed one' in Greek) was born, a bright star was seen in the sky.¹⁶ When Buddha was born he was said to have been a 'bright star' in his mother's womb and when Jesus was born a bright star was seen in the sky.

When Lord Pacal died they say he went to Venus.¹⁷ The last page of Revelation, in the Bible, says that when Jesus died he too became Venus: '... I Jesus ... am the bright and morning star', meaning that the Bible explicitly states that Jesus was Venus.¹⁸ In Peru, a statue of Viracocha appears alongside the 'two children' of Viracocha, the twins, suggesting that he likewise became Venus when he died. A picture in the tomb of Tutankhamun shows the dead king as twins, greeting Osiris, the god of resurrection in the constellation of Orion, meaning that Tutankhamun likewise became Venus when he died.

It becomes clear that Venus, as the brightest star (planet) in the heavens, is associated with spiritual leadership.

The sun shield of Monte Alban is also a Mayan transformer, a picture that transforms into many others when the decoding process is used.

Plate 2b shows a decoded picture of the Gateway of the Sun that today stands at Tiahuanaco in Bolivia on the shores of Lake Titicaca. The reflection (the mirror image) of the gateway can be seen clearly in the water. Closer inspection shows that the Star of David, the geometric symbol of Judaism, is also encoded into the design. When traced it becomes clear that the lower tip of the star ends in the mouth of a bas-relief carving of Viracocha on the lintel of the reflected gateway [appendix 1 explains the significance of the Viracocha bas-relief carving which also turns out to be another Mayan transformer].

Continued analysis of the sun shield reveals another picture showing another representation of Viracocha (plate 3a), similar to one found on the Viracocha vase of Tiahuanaco (plate 3b).

The Euro-Celts

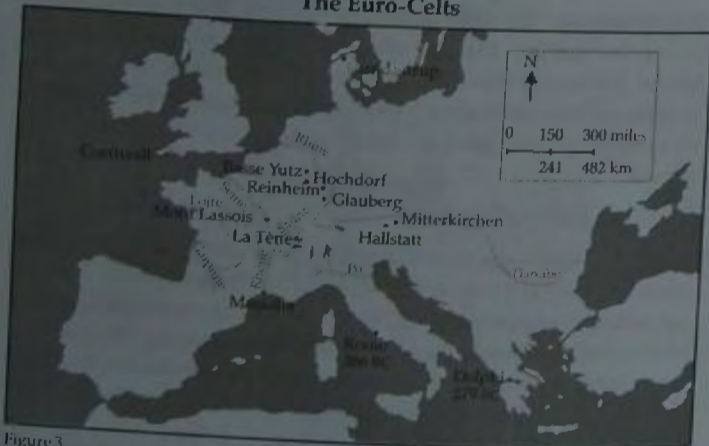

Figure 3

The Carving on the Hallstatt Scabbard

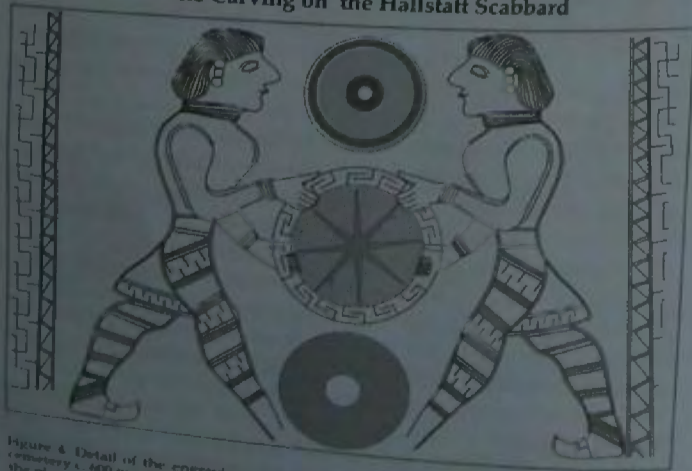

Figure 4 Detail of the engraving on the scabbard (from tomb number 994 in the Hallstatt cemetery c. 400 BC). The centre circle represents the Sun. The top and bottom circles represent the planet Venus, as the morning star and the evening star. The characters either side represent the twins, a metaphor used by all of the sun worshipping civilizations to represent the twin-star (planet) Venus (figure 5). The borders contain an interlaced vertical reverse swastika pattern. The maze-like pattern that circumscribes the centre circle contains encoded secret information.

some on horseback carrying spears and other scenes that are duplicated—as though to emphasise their importance—showing two soldiers holding a wheel (figure 4).

The scene tells us a lot about the Hallsatt Celts; the central circle represents the Sun. The star, inside the circle, shows that the Celts were acutely aware that our Sun is, in the scientific sense, a star. Two circles, one above and one below the Sun symbol represent the twin-star (planet) Venus in its various manifestations as the 'morning star' and the 'evening star' (figure 5) which for 292 days (viewed from the moving Earth) can only be seen in the dark morning sky, before the Sun rises. During the next 292 days Venus can only be seen after sunset, in the dark evening sky. Because it is the brightest and purest source of light in the sky it was associated with love and purity of spirit by sun worshipping civilizations. In the carving the two soldiers, positioned either side of the Sun, represent 'the twins', not only as the twin-star but also as a mirror image of each other. Whenever the ancients referred to the mirror image they were referring to the soul, the mirror image of the body (figure 6).

The borders of the scabbard carving contain a vertical string of interlaced swastikas, a shape which is known to have been used by ancient civilizations as a solar symbol because it is derived from the pattern of the radiating solar wind (figure 7). This means that the Celts of Hallstatt must have known, as early as 600 BC, that the Sun spins on its axis and showers positively charged particles [the nucleus of the hydrogen atom] and negatively charged particles [electrons] towards the Earth. And they must have known about the 'sectored structure' of the radiating solar wind—how it changes alternately from positive to negative every 7 days, in concordance with the underlying magnetic structure of the Sun—facts only recently revealed to modern man in 1962 by data received from Mariner II spacecraft.

The swastika from ancient times evolved as a stylised squared-off version of the solar wind radiation pattern, rather than a facsimile of itself, because the 'square' was the mark of the educated and virtuous man. *The Book of Great Learning*, one of the great Chinese Classics from the school of the philosopher Confucius [d. 479 BC] explains the golden rule (referred to as the measuring square): 'a ruler should treat others as he would have others treat himself'. This sets out the ground rules for a

fertility needs 1,366,040 days after the solar magnetic flip that occurred on the 10th August 3113 BC. In AD 627, 1,366,040 days after the start of their calendar, the Maya began to die, just as they had predicted. For the next 187 years the Sun failed their fertility needs: fewer babies were born; at the same time an increase in solar X-rays, which affected equatorial regions more than other areas,¹⁴ caused an increase in spontaneous foetal abortion and miscarriage throughout Mexico. These events coincided with a solar-inspired mini ice age. Less rain fell globally, but equatorial regions that were less able to cope suffered disproportionately to their neighbours in the north and south from drought, crop failure and famine. It was the end for the Maya.

The Maya encoded the important time interval of 1,366,040 days into one of their treasures, the sun shield of Monte Alban (plate 2a). They also, enigmatically, worshipped a number very close to this, the number 1,366,560, which they referred to as the 'Birth of Venus'. The *Dresden Codex*, one of the ancient Mayan bark books, records that the end of the world, for them, would come after 2,340 revolutions of Venus [2,340 x 584], 1,366,560 days after their calendar began in 3113 BC, meaning that they expected Venus to tilt upside down again in around AD 627.

This means that the swastikas on the Hallstatt scabbard are not drawn incorrectly. The carving is, more than anything, concerned with the planet Venus, which was flipped upside down in 3113 BC by a solar magnetic twist. So Venus now spins on its axis in the opposite direction to the axial rotation of all of the other planets in our solar system. From Venus, the Sun spins on its axis, clockwise, not anticlockwise. The stylised swastika on the Hallstatt scabbard explicitly recognises this by using a reversed (clockwise) swastika, rather than a regular one. Thus the Celts were not so careless after all. But why were the Celts, like the Maya, constantly drawing our attention to Venus?

The Spiritual Secrets of Venus

In 1989, while working at Cranfield University, I calculated the duration of magnetic reversals on the Sun. Using the university's massive computer I determined the figure of 1,366,040 days—the same as the number on the sun shield of Monte Alban, slightly less than the Mayan

14

THE CELTIC CHRONICLES

The Euro-Celts

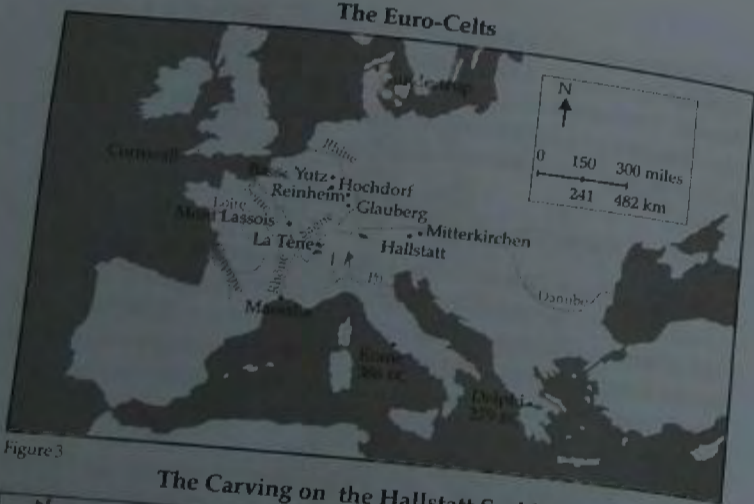

Figure 3

The Carving on the Hallstatt Scabbard



Figure 4. Detail of the engraving on the scabbard (from tomb number 994 in the Hallstatt cemetery c. 600 BC). The centre circle represents the Sun. The top and bottom circles represent the planet Venus, as the morning star and the evening star. The characters either side represent the twins, a metaphor used by all of the sun worshipping civilizations to represent the twin-star (planet) Venus (figure 5). The borders contain an interlaced vertical reverse-swastika pattern. The maze-like pattern that circumscribes the centre circle contains encoded secret information.

8

Birth of Venus number of 1,366,560 days. So why did the Maya, who were aware of the true figure, go to such lengths to refer to the incorrect figure of 1,366,040 days as the Birth of Venus? Was it simply to enable them to track the cycle, knowing that Venus would flip again during the 2,340th Venus revolution as I had initially conjectured?

In 1997 (in *The Supergods*) I showed that many of the world's religious leaders shared much in common;¹⁵ legend says that when Krishna (whose name means 'the anointed one' in Greek) was born, a bright star was seen in the sky.¹⁶ When Buddha was born he was said to have been a 'bright star' in his mother's womb and when Jesus was born a bright star was seen in the sky.

When Lord Pacal died they say he went to Venus.¹⁷ The last page of Revelation, in the Bible, says that when Jesus died he too became Venus: '... I Jesus ... am the bright and morning star', meaning that the Bible explicitly states that Jesus was Venus.¹⁸ In Peru, a statue of Viracocha appears alongside the 'two children' of Viracocha, the twins, suggesting that he likewise became Venus when he died. A picture in the tomb of Tutankhamun shows the dead king as twins, greeting Osiris, the god of resurrection in the constellation of Orion, meaning that Tutankhamun likewise became Venus when he died.

It becomes clear that Venus, as the brightest star (planet) in the heavens, is associated with spiritual leadership.

The sun shield of Monte Alban is also a Mayan transformer, a picture that transforms into many others when the decoding process is used.

Plate 2b shows a decoded picture of the Gateway of the Sun that today stands at Tiahuanaco in Bolivia on the shores of Lake Titicaca. The reflection (the mirror image) of the gateway can be seen clearly in the water. Closer inspection shows that the Star of David, the geometric symbol of Judaism, is also encoded into the design. When traced it becomes clear that the lower tip of the star ends in the mouth of a bas-relief carving of Viracocha on the lintel of the reflected gateway [appendix 1 explains the significance of the Viracocha bas-relief carving which also turns out to be another Mayan transformer].

Continued analysis of the sun shield reveals another picture showing another representation of Viracocha (plate 3a), similar to one found on the Viracocha vase of Tiahuanaco (plate 3b).

15

THE CELTS

some on horseback carrying spears and other scenes that are duplicated—as though to emphasise their importance—showing two soldiers holding a wheel (figure 4).

The scene tells us a lot about the Hallstatt Celts; the central circle represents the Sun. The star, inside the circle, shows that the Celts were acutely aware that our Sun is, in the scientific sense, a star. Two circles, one above and one below the Sun symbol represent the twin-star (planet) Venus in its various manifestations as the 'morning star' and the 'evening star' (figure 5) which for 292 days (viewed from the moving Earth) can only be seen in the dark morning sky, before the Sun rises. During the next 292 days Venus can only be seen after sunset, in the dark evening sky. Because it is the brightest and purest source of light in the sky it was associated with love and purity of spirit by sun worshipping civilizations. In the carving the two soldiers, positioned either side of the Sun, represent 'the twins', not only as the twin-star but also as a mirror image of each other. Whenever the ancients referred to the mirror image they were referring to the soul, the mirror image of the body (figure 6).

The borders of the scabbard carving contain a vertical string of interlaced swastikas, a shape which is known to have been used by ancient civilizations as a solar symbol because it is derived from the pattern of the radiating solar wind (figure 7). This means that the Celts of Hallstatt must have known, as early as 600 BC, that the Sun spins on its axis and showers positively charged particles [the nucleus of the hydrogen atom] and negatively charged particles [electrons] towards the Earth. And they must have known about the 'sectored structure' of the radiating solar wind—how it changes alternately from positive to negative every 7 days, in concordance with the underlying magnetic structure of the Sun—facts only recently revealed to modern man in 1962 by data received from Mariner II spacecraft.

The swastika from ancient times evolved as a stylised squared-off version of the solar wind radiation pattern, rather than a facsimile of itself, because the 'square' was the mark of the educated and virtuous man. *The Book of Great Learning*, one of the great Chinese Classics from the school of the philosopher Confucius [d. 479 BC] explains the golden rule (referred to as the measuring square): 'a ruler should treat others as he would have others treat himself'. This sets out the ground rules for a

9

Further analysis reveals the picture of the distinctive head and face of Lord Pacal, the priest-king leader of the Maya in around AD 750, regurgitating a pearl from his mouth (plate 3c). The pearl is an ancient symbol used by many sun-worshipping civilizations to represent rebirth, or reincarnation. In the tomb of Lord Pacal at the Pyramid of Inscriptions, Palenque, a pearl was found in a seashell filled with cinnabar (the powdered form of liquid mercury) at the bottom of the stairs suggesting that Lord Pacal was reborn as the white planet Venus in Heaven [so inferred because the atomic number of the element cinnabar is 80. The pearl, in the cinnabar, thus becomes object number 81, 81 is composed of nine 9s, and 9 is the number of the soul, God or a Supergod].

The picture of Lord Pacal, in plate 3c, is contained within a vesica pisces, the geometric symbol of Christianity which is derived from two overlapping circles (plate 3d) representing the various manifestations of Venus. The series of decoded pictures (figure 9) suggests that Judaism (represented by the Star of David), Viracocha of Tiahuanaco and Lord Pacal are all associated with Christianity (the vesica pisces). Plate 5 shows archaeological evidence from Central America to support the hypothesis. Moreover, the picture of Lord Pacal regurgitating a pearl (plate 3c) further suggests reincarnation and 'rebirth as Venus'.

We have already seen that Lord Pacal was Venus. Viracocha was Venus and Jesus was Venus. The inference must be that Jesus was born again as Viracocha and again as Lord Pacal. So here again we have 'the birth of Venus', just as we do with the Mayan number 1,366,560.

By using the two similar figures, the true scientific figure of 1,366,040 to describe magnetic reversals that cause infertility cycles and cause Venus to flip upside down on its axis [that is, cause Venus to be reborn]—and another very close figure of 1,366,560—referred to as the 'birth of Venus' (because it amounts to 2,340 revolutions of Venus)—they were attempting to convey the fact that 'Venus is reborn'. They were trying to tell us that Jesus, who was the Sun on Earth (light), was reborn as Lord Pacal, he was 'the rebirth of Venus', the rebirth of Jesus. Mayan transformers were just one of the living miracles that he left behind. Again, that this is the case is supported by more incredible composite pictures from the sun shield of Monte Alban, featured in plates 6-13, that show Lord Pacal as a stag, the birth of the baby Jesus,

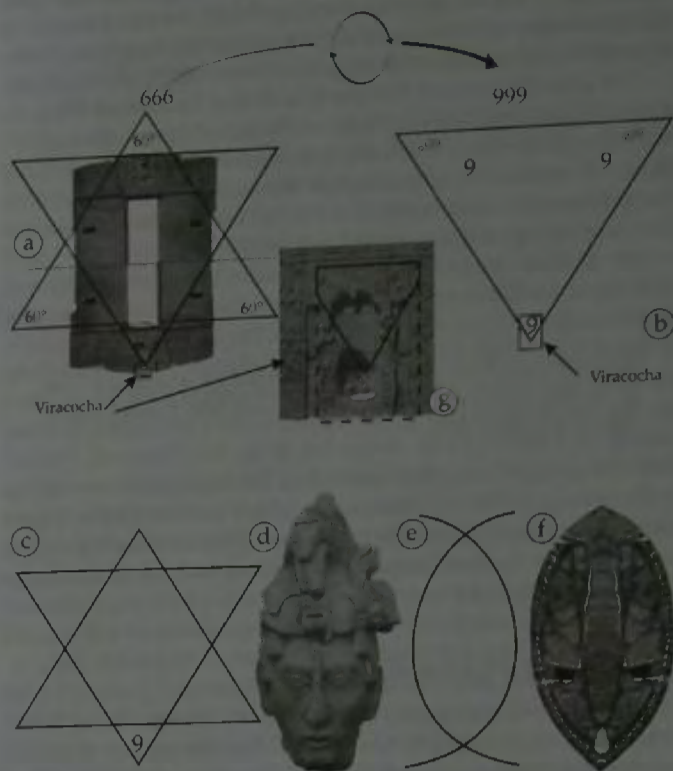

Figure 9. (a) Above and plate 2c show the decoded picture of a Star of David [the geometric symbol of Judaism] together with the Gateway of the Sun from Tiahuanaco, Bolivia. Note that the bas-relief carving of Viracocha on the gateway is positioned in the lower point of the star (b) corresponding to the number 9; meaning that Viracocha's number is 9, the number of a Supergod. (c) Plate 3c shows the decoded picture of a vesica pisces [the geometric symbol of Christianity] around the head and face of Lord Pacal. This reveals that Lord Pacal of Mexico (c. AD 750) and Viracocha (c. AD 500) were the same man as Jesus the Jew (c. AD 26)—different incarnations of Jesus on Earth. All three appear in decoded pictures from the sun shield, meaning that all three come from the Sun—all three were light, or God; proving that the sun shield of Monte Alban is a living miracle which shows the first pictures of Jesus. (f) In plate 3c Lord Pacal regurgitates a pearl. Regurgitation of a pearl (see main text) is a metaphor for the reincarnation of Venus (a Supergod) on Earth. Note the 66 pearls around the perimeter of Lord Pacal's head in (f). (g) The reason why the tip of the star forms the tongue of Viracocha is explained in appendix 1.

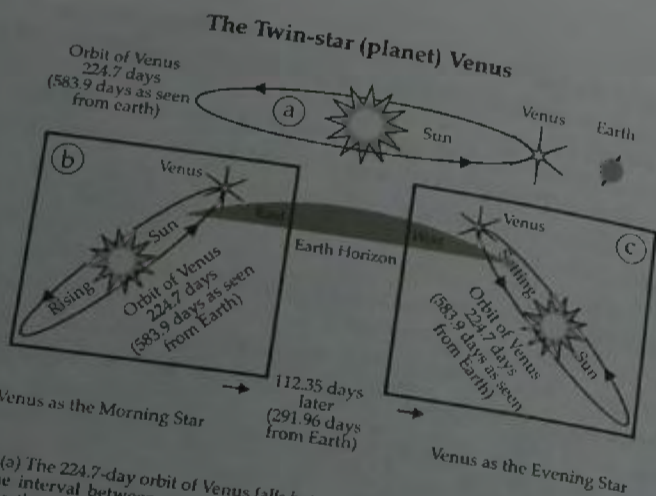
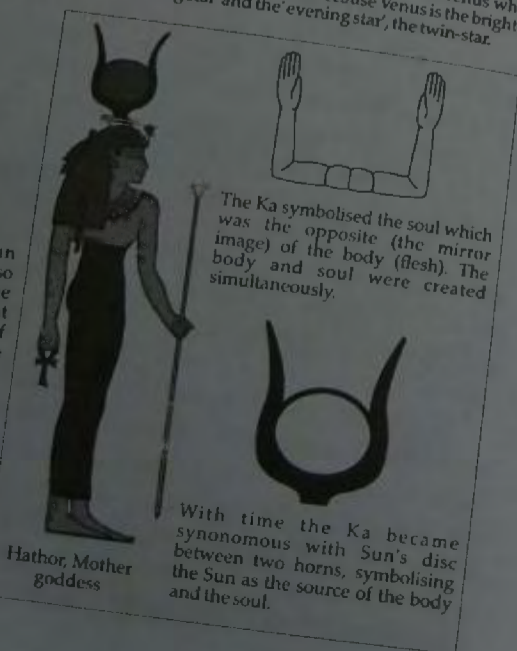

Figure 5. (a) The 224.7-day orbit of Venus falls between that of Mercury (not shown here) and Earth. The interval between successive identical appearances of Venus, as seen from the moving Earth, is 583.9 days. This means that Venus, in the position shown in (b), appears brightly illuminated in the dark morning sky. In position (c) the Sun sets before Venus which shines brightly in the darkening evening sky. Because of this, and because Venus is the brightest heavenly body, she is referred to as the 'morning star' and the 'evening star', the twin-star.

The Body, the Soul and the Sun

Figure 6. The ancient sun worshipping Egyptians also believed that the soul was the mirror image of the body [that the left is the mirror image of the right] and that the Sun (God) separates the body from the soul.



Hathor, Mother goddess

With time the Ka became synonymous with Sun's disc between two horns, symbolising the Sun as the source of the body and the soul.

relationship between two parties, as a measuring square sets into stone the relationship between two sides; bearing a close relationship to the Christian ethos that appeared much later.

The astute reader may have noticed that the swastikas in the Hallstatt scabbard carving borders are in fact reversed-swastikas, rotating clockwise instead of, more correctly, counter-clockwise, like the solar wind water-sprinkler pattern detected by Mariner II (figure 7b). Which means, surely (to the sceptic), that the Celts who carved the picture on the scabbard in fact knew nothing of the solar wind, nothing of the meaning of the square and nothing of astronomy? But these people were much cleverer than that—as were the Mayas, Egyptians, Peruvians and Chinese.

The Mystery of the Hallstatt Swastikas

As the Sun spins on its axis every 28 days the showering positive and negative electrical particles collide with the Van Allen belts (figure 8b), the protective magnetic fields that encircle the Earth. Caught in the belts, the particles spiral between North Pole and Soul Pole every second causing the Earth's magnetic field to vary at ground level.

In 1989, Dr Ross Aidez, the White House chief medical advisor under the Regan administration, discovered that the brains of rats, pigeons and guinea-pigs produce varying amounts of the timing hormone melatonin when bombarded by varying amounts of modulated magnetic fields. Melatonin stimulates the pituitary gland in the human brain that in turn affects the production of the luteinizing hormone and follicle-stimulating hormone. These in turn regulate the production of the fertility hormones oestrogen and progesterone in females¹². So as the Sun spins every 28 days it showers charged particles to the Earth which regulate the menstrual function in females every 28 days, which explains why the ancient sun worshipping civilizations worshipped the Sun as the God of Fertility.

The spinning Sun also gives rise to magnetic cycles on the Sun's surface causing the Sun's magnetic field to shift from a north-easterly direction to a south-easterly direction every few thousand years [the calculations are complex and non-periodic]. This magnetic twist has the effect of flipping the planets in our solar system upside down in their orbits. Clearly those nearest to the Sun will be affected most, the stronger the

the adult life of Jesus, Jesus carrying the cross and Jesus dying on the cross. Plate 12 reveals the mechanism by which the Amazing Lid of Palenque can be decoded, and plate 13 suggests that those who live by the body find only death whereas those of the 144,000 find eternal life.

The ancients believed that the Son of God has visited Earth on many occasions, as Krishna in India c. 1700 BC, as Tutankhamun c. 1353 BC; as Buddha c. 450 BC; as Ch'in Shi Huangdi c. 220 BC; as Jesus, as the legendary white Gods Viracocha Pachacamac [God of the World] c. AD 300 and Viracocha [foam of the sea] c. AD 500, who walked the lands of Peru performing miracles; and as Lord Pacal of the Maya, c. AD 750.

As Krishna says, during his discourse with the prodigy soldier Arjuna, in the Bhagavad Gita, part of the epic Indian poem the Mahabharata:

Whenever spirituality decays and materialism is rampant, then,
O Arjuna! I reincarnate myself'. (*The Gita*, Shri Purohit Swami,
Faber and Faber, 1982)

The Hallstatt Celts not only understood the super-science of the Sun but by featuring Venus so prominently in their carvings declared a pre-occupation with, and a knowledge of, each of the world's religions past and present and in so doing reveal that they understood the higher orders of spirituality.

The Tomb of the King of Hochdorf

Renate Liebfried, the deputy for Monument Preservation in Baden-Wuerttemberg, in Germany, was often called out to examine stones and timber ploughed up on the ancient earth-covered barrow at Hochdorf. Eventually it became clear that a circular ring of logs, spaced at around 3-metre intervals, had been buried vertically all around the 188-metre- (617-foot-) perimeter of the tumulus creating a henge along the lines of Stonehenge-1 in England. In 1978, archaeologist Dr. Joel Biel decided to excavate before any more of the tumulus was damaged from agricultural activity. The 6-metre- (19-foot 8 inch-) high mound was surrounded by a wide trench.

About a year after excavations began a central rubble-filled shaft, measuring 4.7 metres (15 feet 5 inches) square, began to emerge, run-

ning down through the centre of the mound. Digging continued down to around ground level when they hit what appeared to be a timber platform. Unsure as to what they might find, they pressed on cautiously. Lifting the timbers, all they could see were fabrics draped on the walls and floor of a shallow chamber.

Entering the chamber they could only guess at what might lie below. Could this be the tomb of a 'Celtic Princess', like the one excavated in 1953 at the foot of the Celtic hill-fort at Mont Lassois, near Châtillon-sur-Seine in France, about 200 miles (322 km) west-southwest of where they were now digging? She was aged around thirty-five and estimated to be around 1.72 metres (5 feet 7 inches) tall. They found her laid out on a four-wheeled wooden wagon surrounded by all kinds of treasures, many of Greek origin including a massive 1.65-metre- (5-foot 5-inch-) high bronze urn that could hold 500 litres (132 gallons) of honey mead, three stone bracelets, a bronze bracelet with amber beads (on each wrist), two bronze anklets, amber and stone beads, bronze fibulae¹⁹ decorated with coral and amber, and iron and gold fibulae together with a magnificent gold torc weighing 0.5 kg (1.1 lb.). The word *torc* derives from the Latin *torque*, referring to a twisted piece of flattened metal that the early decorative collars resembled. They became more popular throughout Europe after the Hallstatt period and developed from a simple twisted strip of gold wrapped around the neck like an open hoop to more ornate arrangements.

Their flashlights beamed into the dust-filled void below picking out a chamber 2.5 metres (8 feet 2 inches) deep and 7.4 metres (24 feet 3 inches) by 7.5 metres (23 feet 7 inches) wide, just below ground level. All they could see were woven and embroidered textiles and sheets draped around the walls and others, perhaps in bundles, on the floor.

Moments later the roof collapsed, crashing down into the space below, taking them with it. Soon it became clear, through the debris, that the chamber was constructed entirely of timbers (figure 10). The deck comprised sixteen short timbers and one longer end-timber, laid side by side. The walls were made of a stack of six longer-length timbers each carved with a mortise cavity to accommodate the tenon-like transverse interlocking beams. The arrangement of beams seemed over-elaborate. Why would anyone go to so much trouble to build such a sophisticated structure?

The Sun, the Solar Wind and the Swastika

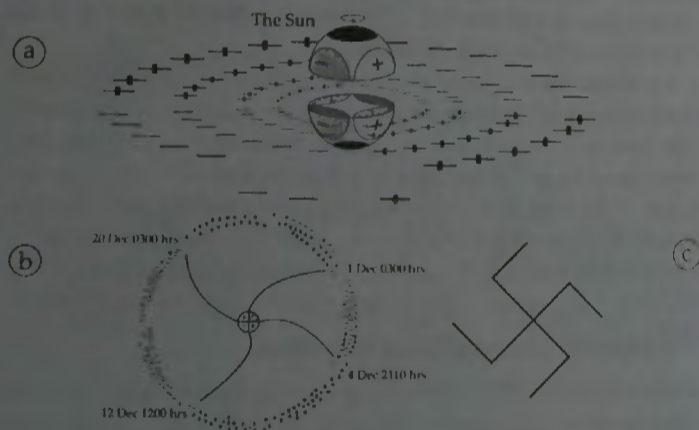

Figure 7 (a) The Sun radiates charged particles (the solar wind) and showers them towards Earth, like a water sprinkler. (b) The sectored-structure of the solar wind was first detected by Mariner II spacecraft in 1962, and plotted by IMP I (Interplanetary spacecraft I) in 1963. (c) The swastika represents a schematic of the solar wind pattern and was worshipped by many ancient sun worshipping civilizations.

How the 28-day Spinning Sun Regulates Menstruation in Females

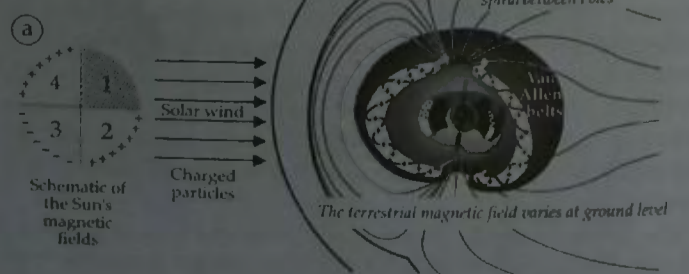

Figure 8 (a) The Sun spins on its axis and radiates charged particles to Earth. (b) The resulting varying magnetic field (at ground level) affects the manufacture of DNA in humans at conception, causing four types of genetic mutations, three times every year, resulting in 12 different types of personality (sun-sign Astrology). It later affects the human brain, causing variations in the production of the timing hormone melatonin every 28 days causing variations in the production of the fertility hormones oestrogen and progesterone every 28 days.

magnetic shift the stronger the effect will reach out into space and the more planets will be affected. Examination of historical solar magnetic activity reveals that a magnetic shift occurred in 3113 BC causing Venus to flip upside down on its axis¹³.

The 1950s writer, historian and scientist Immanuel Velikovsky, believed that this 'birth of Venus' had been recorded the world over. In *Worlds in Collision* he wrote:

In Greece, the goddess who suddenly appeared in the sky was Pallas Athene. She sprang from the head of Zeus-Jupiter. To the Chinese, Venus spanned the heavens, rivalling the Sun in brightness. 'The brilliant light of Venus', noted one ancient rabbinical record 'blazes from end of the cosmos to the other'. (Immanuel Velikovsky, *Worlds in Collision*, Book Club Associates, 1973).

Clearly, the Earth, which is further from the Sun than Venus, and less susceptible to topple on its axis for a given magnetic field strength, did not topple in 3113 BC.

Orthodox Archaeologists have always been perplexed as to why Maya calendrical inscriptions all refer back to a starting date in 3113 BC, because the Maya civilization did not appear in Mexico prior to the Teotihuacan period of around AD 100.

The Maya were master astronomers and knew—as we now know—that the Sun's radiation affects fertility on Earth, which is why they worshipped the Sun as the God of Fertility. Because they knew just how important the Sun's radiation was to life on Earth they monitored the Sun's radiation patterns, knowing that the Sun would fail their fertility needs 1,366,040 days after the solar magnetic flip that occurred on the 10th August 3113 BC. In AD 627, 1,366,040 days after the start of their calendar, the Maya began to die, just as they had predicted. For the next 187 years the Sun failed their fertility needs; fewer babies were born; at the same time an increase in solar X-rays, which affected equatorial regions more than other areas¹⁴, caused an increase in spontaneous foetal abortion and miscarriage throughout Mexico. These events coincided with a solar-inspired mini ice age. Less rain fell globally, but equatorial regions that were less able to cope suffered disproportionately to their neighbours in the North and South from drought, crop failure and famine. It was the end for the Maya.

The Tomb of the King of Hochdorf

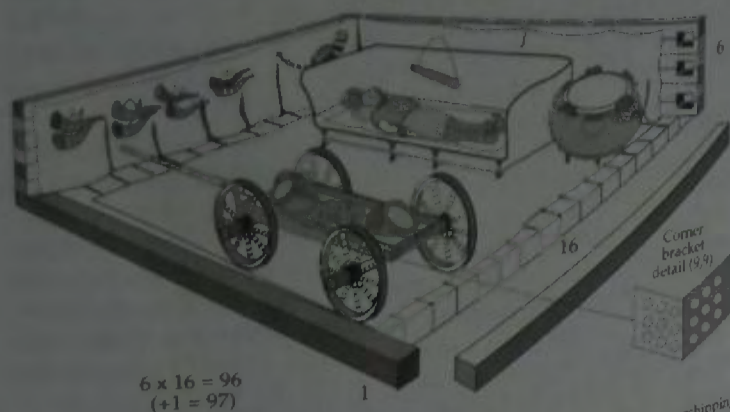

Figure 10. The Hochdorf tomb shares much in common with the tombs of other sun-worshipping kings. The Celts, like the Maya, Peruvians, Egyptians and the ancient Chinese, encoded the super-science of the Sun and the higher orders of spirituality into their treasures.

The enigma of the elaborate timbers concealed the true purpose of the tomb and its contents: the numbers and lengths of beams crucially convey the numbers 96 and 97. Appendix 2 explains how and why the ancients preferred to use numbers to encode esoteric information into their treasures. Figure 11 shows the numbers and explains why they chose them. Here again, this time at Hochdorf, we begin to see the emergence of an ancient practice that uses the same numbers used by other sun-worshipping civilisations in an attempt to convey the long lost knowledge of the Sun and the higher orders of spirituality.

The early Chinese were among the first to notice the periodic appearance of small black spots on the Sun's surface that manifest approximately every 11.5 years (figure 23b). Sixteen sunspot cycles subsist within every 187-year period. The same information was carved into a tablet by the Maya at their ceremonial site of Palenque, c. AD 750 (figure A12), encoded into the tomb design of Tutankhamun, c. AD 1353 (figure A13), and encoded into the tomb timbers of Viracocha Pachacamac in Peru, c. AD 300 (figures 12 and A14). These revelations, together with

Encoding Information Using Numbers

1,1 2,2 3,3
4,4 5,5 6,6
7,7 8,8 9,9 Numerical matrix often found in ancient tomb treasures to draw attention to the practice of encoding using numbers. Appendix 2 (figure A17) shows one example from the Pyramid of Inscriptions, Mexico.

Numbers used to encode esoteric spiritual knowledge

- 666 The Earth is carbon based. The Carbon atom consists of 6 negative charges (electrons), 6 positive charges (protons) and 6 non-charged particles (neutrons). The number appears in the Bible; 'here is wisdom, let him that hath understanding count the number of the beast; for it is the number of a man; and his number is 666 ...' (Revelation XIII, 18)
- 999 9 is the highest number that can be reached before becoming one with God (as in 10). 999 thus represents Heaven above, God, the soul or a Supergod—a spiritual teacher. 666 represents the Earth below, Hell or the Devil. The purpose of life is to convert the body, 666, into Godly energy, 999.
- 144,000 Biblical number, refers to those destined for Heaven... 'I saw four angels standing on the four corners of the Earth holding the four winds of the Earth, that the wind should not blow on the Earth, nor on the sea nor on any tree. And I saw another angel ascending from the east having the seal of the living God: And he cried with a loud voice to the four angels, to whom it was given to hurt the Earth, and the sea, saying "Hurt not the Earth, neither the sea, nor the trees, till we have sealed the servants of our God in their foreheads". And I heard the number of them which were sealed; and there were sealed an hundred and forty-four thousand [144,000] of all the tribes of the children of Israel'. (Revelation VII, 14)

Numbers used to encode scientific knowledge—the super-science of the Sun

- 26 The time it takes, in days, for the Sun's equator to spin once on its axis.
- 28 The time it takes, in days, for the Sun's equator to spin once on its axis, viewed from the moving Earth.
- 37 The time it takes, in days, for the Sun's magnetic polar cap to spin once on its axis.
- 41 The time it takes, in days, for the Sun's magnetic polar cap to spin once on its axis, viewed from the moving Earth.
- 96 The number of solar magnetic cycles that subsist on the Sun every 187 years (made up of 16 observable 11.5-year (approximately) sunspot cycles (figure A11)).
- 97 The number of solar magnetic cycles that need to be recognised when calculating the longer magnetic cycle of 18,139 years (figure A11).
- 20 The number of 187-year magnetic cycles that occur during 1 solar neutral sheet magnetic reversal of 3,740 years (1,366,040 days as calculated by computer).
- 1,366,040 The interval, in days, between solar magnetic reversals that cause Venus to physically flip on its axis (encoded into the sun shield of Monte Alban by the Maya (plate 2)).
- 1,366,560 The Maya tracked the 1,366,040 interval using Venus; 2,340 revolutions of Venus (2,340 x 584) take 1,366,560 days, measured from the start date of their calendar in 3113 BC. They called the number 'the birth of Venus' but, importantly, only as a metaphor to describe the spiritual rebirth of Venus—Lord Pacal was the 'rebirth of Venus' (Jesus).

Figure 11.

The Maya encoded the important time interval of 1,366,040 days into one of their treasures, the sun shield of Monte-Alban (plate 2a). They also, enigmatically, worshipped a number very close to this, the number 1,366,560, which they referred to as the 'Birth of Venus'. The Dresden Codex, one of the ancient Maya bark books, records that the end of the world, for them, would come after 2,340 revolutions of Venus [2,340 x 584], 1,366,560 days after their Calendar began in 3113 BC, meaning that they expected Venus to tilt upside down again in around AD 627.

This means that the swastikas on the Hallstatt scabbard are not drawn incorrectly. The carving is, more than anything, concerned with the planet Venus, which was flipped upside down in 3113 BC by a solar magnetic twist. So Venus now spins on its axis in the opposite direction to the axial rotation of all of the other planets in our solar system. From Venus, the Sun spins on its axis, clockwise, not anticlockwise. The stylised swastika on the Hallstatt scabbard explicitly recognises this by using a reversed (clockwise) swastika, rather than a regular one. So the Celts were not so careless after all. But why were the Celts, like the Mayas, constantly drawing our attention to Venus?

The Spiritual Secrets of Venus

In 1989, while working at Cranfield University, I calculated the duration of magnetic reversals on the Sun. Using the University's massive computer I determined the figure of 1,366,040 days—the same as the number on the sun shield of Monte Alban—slightly less than the Maya Birth of Venus number of 1,366,560 days. So why did the Maya, who were aware of the true figure, go to such lengths to refer to the incorrect figure of 1,366,560 days as the Birth of Venus, was it simply to enable them to track the cycle, knowing that Venus would flip again during the 2,340th Venus revolutions as I had initially conjectured?

In 1997 (in *The Supergods*) I showed that many of the World's religious leaders shared much in common¹⁵; legend says that when Krishna¹⁶ (whose name means 'the anointed one' in Greek) was born, a bright star was seen in the sky. When Buddha was born he was said to have been a 'bright star' in his mothers womb and when Jesus was born a bright star was seen in the sky.

When Lord Pacal died they say he went to Venus¹⁷. The last page of Revelation, in the Bible, says that when Jesus died he too became Venus:

'...I Jesus...am the bright and morning star', meaning that the Bible explicitly states that Jesus was Venus¹⁸. In Peru, a statue of Viracocha appears alongside the 'two children' of Viracocha, the twins, suggesting that he likewise became Venus when he died. A picture in the tomb of Tutankhamun shows the dead king as twins, greeting Osiris, the God of Resurrection in the constellation of Orion, meaning that Tutankhamun likewise became Venus when he died.

It becomes clear that Venus, as the brightest star (planet) in the heavens, is associated with spiritual leadership.

The sun shield of Monte Alban is also a Maya Transformer, a picture that transforms into many others when the decoding process is used.

Plate 2b shows a decoded picture of the Gateway of the Sun that today stands at Tiawanaco in Bolivia on the shores of Lake Titicaca (plate 2c). The reflection (the mirror image) of the Gateway can be seen clearly in the water. Closer inspection shows that the Star of David, the geometric symbol of Judaism, is also encoded into the design. When traced it becomes clear that the lower tip of the star ends in the mouth of a bas-relief carving of Viracocha on the lintel of the reflected gateway (Appendix 1 explains the significance of the Viracocha bas relief carving which also turns out to be another Maya Transformer).

Continued analysis of the sun shield reveals another picture showing another representation of Viracocha (plate 3a); similar to one found on the Viracocha Vase of Tiawanaco (plate 3b).

Further analysis reveals the picture of the distinctive head and face of Lord Pacal, the priest-king leader of the Maya in around AD 750, regurgitating a pearl from his mouth (plate 3c). The pearl is an ancient symbol used by many sun worshipping civilisations to represent re-birth, or re-incarnation. In the tomb of Lord Pacal at the Pyramid of Inscriptions, Palenque, a pearl was found in a seashell filled with cinnabar (the powdered form of liquid mercury) at the bottom of the stairs suggesting that Lord Pacal was reborn as the white planet Venus in Heaven [so inferred because the atomic number of the element Cinnabar (the powdered form of the liquid metal mercury) is 80]. The pearl, in the Cinnabar, thus becomes object number 81. 81 is comprised of nine 9s, and 9 is the number of the soul, God or a Supergod].

The picture of Lord Pacal, in Plate 3c, is contained within a vesica pisces,

The Tomb Timbers of Viracocha Pachacamac

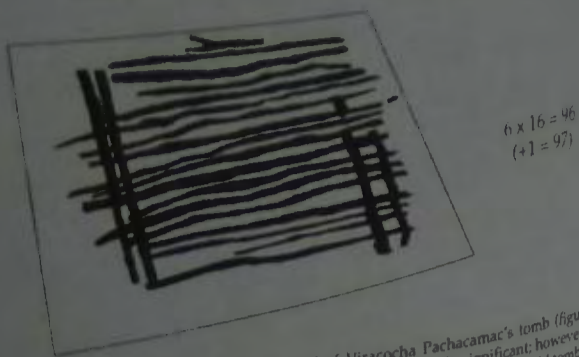

Figure 12. 16 wooden beams supported the roof of Viracocha Pachacamac's tomb (figure A8). 5 Y-shaped wooden beams supported these. 5 x 16 is not astronomically significant; however we note that one Y-shaped beam was found on top of the roof (top centre, above). Why would tomb-builders place one of six supports on top of the roof? The message here is that 6 is important: 6 x 16 = 96, the number of magnetic cycles in one sunspot cycle (figures A11, A12 and A13). One more transverse beam (figure A14) was embedded in the bricks (making a total of 97) but this did not support the roof.

the fact that the central shaft running down through the tumulus was exactly square [4.7 metres (15 feet 5 inches)], announce that the tomb designer was both aware of the sunspot cycle (the super-science of the Sun) and was also 'on the square', a virtuous man who was aware of the higher orders of spirituality. This had to be the tomb of a long-lost Supergod.

Removal of the sheeting used to wrap much of the contents of the tomb revealed what archaeologists described as the remains of an ancient 'Celtic Prince'. His bones were those of a Caucasian 1.87 metres (6 feet 1 inch) tall who was aged about forty-five years old when he died in around 550 BC.

He was wrapped in several woven blankets that were decorated with reverse-swastika patterns, identifying him with the planet Venus. At one end of the chamber, eight organic drinking horns hung from the wall in pairs alongside another larger, more decorative nine-section iron horn. That one appears to have a mouthpiece, plugged by a detachable stopper, and could therefore have been used as a

sounding-horn. The ornate stopper consists of a slim tapering tube. A solar-style convex disc sits on the end, like an open umbrella, and a tiny white bead, fastened to the centre of the disc, terminates the end of the horn. What appear to be two identical tiny cast characters kneel either side of the tube with their arms raised as though worshipping the sun disc at the end.

The King lay on his back on a 3-metre- (9-foot-) long bronze funerary couch, made of six riveted bronze sheets, supported by eight caryatids (figure 13) adopting the raised-arm stance of the two sun worshippers found on the end of the iron horn [and similar characters found in the tombs of Lord Pacal and the Viracochas (plates 5b and 5c)]. Whether the figures are truly [female] caryatids, or male, is not clear. In any event, the dead man, above, was the ninth (9th) occupant of the couch, just as Viracocha Pachacamac was the ninth occupant of his tomb (figure A14).

Each of the caryatids stands, astride, on the axle of a bronze wheel decorated with red coral disc incrustations, emulating sunspots, suggesting that the dead man was preoccupied with the spinning Sun on its axis. The chest of each caryatid is pierced with a square stud, meaning that the man they carried, above, had a square heart, a pure heart, just like Lord Pacal and Viracocha Pachacamac.

A longbow lay beside the body and a quiver for arrows containing bronze and iron arrowheads—all that was left of the arrows—hung from the backrest of the couch. This did not necessarily mean that he was a hunter but more likely referred to the fact that as a spiritual teacher, like Tutankhamun who is portrayed in his tomb paintings firing arrows and like the terracotta archers from the mausoleum of Ch'in Shi Huangdi, he 'aimed at the heart'; he came to purify the hearts of others. His birchbark conical cap rested on the end of the couch behind his head, making a halo fit for a king.

He was adorned with jewellery: a gold neckband, a gold bracelet and a 33-cm- (13-inch-) long, 8.5-cm (3-inch-) wide belt cover made from a band of sheet gold. A 42-cm (16-inch) bronze scabbard with a bronze cast wheel shape at the sharp end rested on the belt around his waist. The under-side of the scabbard was dulled with patina but the surface, covered in gold foil, shone brightly in the flashlights of the excavators. The scabbard sheath concealed an iron dagger topped

The Secrets of the Sun Shield of Monte Alban

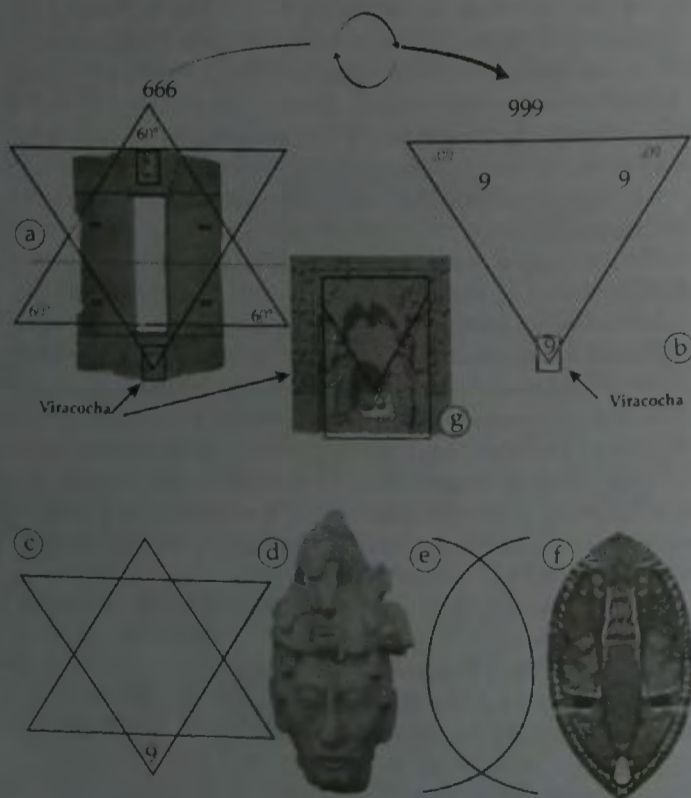

Figure 9. (a) Above and plate 2b show the decoded picture of a Star of David [the geometric symbol of Judaism] together with the Gateway of the Sun from Tiahuanaco, Bolivia. Note that the bas-relief carving of Viracocha on the Gateway is positioned in the lower point of the star (b) corresponding to the number 9, meaning that Viracocha's number is 9, the number of a Supergod. (c) Plate 3c shows the decoded picture of a vesica pisces [the geometric symbol of Christianity] around the head and face of Lord Pacal. This reveals that Lord Pacal or Venero (c. AD 750) and Viracocha (c. AD 500) were the same man as Jesus the Jew (c. AD 26)—different incarnations of Jesus on Earth. All three appear in decoded pictures from the sun shield, meaning that all three come from the Sun—all three were light, or God; proving that the sun shield of Monte Alban is a living miracle which shows the first pictures of Jesus. (f) In plate 3c Lord Pacal regurgitates a pearl. Regurgitation of a pearl (see main text) is a metaphor for the reincarnation of Venus (a Supergod) on Earth. Note the 66 pearls around the perimeter of Lord Pacal's head in (f). (g) The reason why the tip of the star forms the tongue of Viracocha is explained in Appendix 1.

the geometric symbol of Christianity which is derived from two overlapping circles (plate 3d) representing the various manifestations of Venus. The series of decoded pictures (figure 9) suggests that Judaism (represented by the star of David), Viracocha of Tiahuanaco and Lord Pacal, are all associated with Christianity (the vesica pisces). Plate 5 shows archaeological evidence from Central America to support the hypothesis. Moreover, the picture of Lord Pacal regurgitating a pearl (plate 3c) further suggests reincarnation and 'rebirth as Venus'.

We have already seen that Lord Pacal was Venus, Viracocha was Venus and Jesus was Venus. The inference must be that Jesus was born again as Viracocha and again as Lord Pacal. So here again we have 'the birth of Venus', just as we do with the Maya number 1,366,560.

By using the two similar figures, the true scientific figure of 1,366,040 to describe magnetic reversals that cause infertility cycles and cause Venus to flip upside down on its axis [that is, cause Venus to be reborn]—and another very close figure of 1,366,560—referred to as the 'birth of Venus' (because it amounts to 2,340 revolutions of Venus)—they were attempting to convey the fact that 'Venus is reborn'. They were trying to tell us that Jesus, who was the Sun on Earth (light) was reborn as Lord Pacal, he was 'the rebirth of Venus', the rebirth of Jesus. Maya transformers were just one of the living miracles that he left behind. Again, that this is the case is supported by more incredible composite pictures from the sun-shield of Monte Alban featured in plates 6-13 that show Lord Pacal as a stag, the birth of the baby Jesus, the adult life of Jesus, Jesus carrying the cross and Jesus dying on the cross. Plate 12 reveals the mechanism by which the Amazing Lid of Palenque can be decoded and plate 13 suggests that those who live by the body find only death whereas those of the 144,000 find eternal life.

The ancients believed that the Son of God has visited Earth on many occasions, as Krishna in India c. 1700 BC, as Tutankhamun c. 1353 BC; as Buddha c. 450 BC; as Ch'in Shi Huangdi c. 220 BC; as Jesus, as the legendary white Gods Viracocha Pachacamac [God of the World] c. AD 300 and Viracocha [foam of the sea] c. AD 500, who walked the lands of Peru performing miracles; and as Lord Pacal of the Maya, c. AD 750.

As Krishna says, during his discourse with the prodigy soldier Arjuna,

The Tomb Timbers of Viracocha Pachacamac

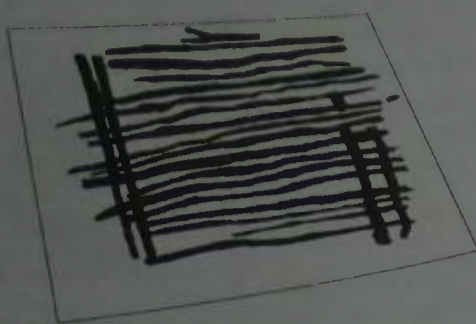

$$6 \times 16 = 96$$

$$(+1 = 97)$$

Figure 12. 16 wooden beams supported the roof of Viracocha Pachacamac's tomb (figure A8). 5 Y-shaped wooden beams supported these. 5×16 is not astronomically significant; however we note that one Y-shaped beam was found on top of the roof (top centre, above). Why would tomb-builders place one of six supports on top of the roof? The message here is that 6 is important: $6 \times 16 = 96$, the number of magnetic cycles in one sunspot cycle (figures A11, A12 and A13). One more transverse beam (figure A14) was embedded in the bricks (making a total of 97) but this did not support the roof.

the fact that the central shaft running down through the tumulus was exactly square [4.7 metres (15 feet 5 inches)], announce that the tomb designer was both aware of the sunspot cycle (the super-science of the Sun) and was also 'on the square', a virtuous man who was aware of the higher orders of spirituality. This had to be the tomb of a long-lost Supergod.

Removal of the sheeting used to wrap much of the contents of the tomb revealed what archaeologists described as the remains of an ancient 'Celtic Prince'. His bones were those of a Caucasian 1.87 metres (6 feet 1 inch) tall who was aged about forty-five years old when he died in around 550 BC.

He was wrapped in several woven blankets that were decorated with reverse-swastika patterns, identifying him with the planet Venus. At one end of the chamber, eight organic drinking horns hung from the wall in pairs alongside another larger, more decorative nine-section iron horn. That one appears to have a mouthpiece, plugged by a detachable stopper, and could therefore have been used as a

sounding-horn. The ornate stopper consists of a slim tapering tube. A solar-style convex disc sits on the end, like an open umbrella, and a tiny white bead, fastened to the centre of the disc, terminates the end of the horn. What appear to be two identical tiny cast characters kneel either side of the tube with their arms raised as though worshipping the sun disc at the end.

The King lay on his back on a 3-metre- (9-foot-) long bronze funerary couch, made of six riveted bronze sheets, supported by eight caryatids (figure 13) adopting the raised-arm stance of the two sun worshippers found on the end of the iron horn [and similar characters found in the tombs of Lord Pacal and the Viracochas (plates 5b and 5c)]. Whether the figures are truly [female] caryatids, or male, is not clear. In any event, the dead man, above, was the ninth (9th) occupant of the couch, just as Viracocha Pachacamac was the ninth occupant of his tomb (figure A14).

Each of the caryatids stands, astride, on the axle of a bronze wheel decorated with red coral disc incrustations, emulating sunspots, suggesting that the dead man was preoccupied with the spinning Sun on its axis. The chest of each caryatid is pierced with a square stud, meaning that the man they carried, above, had a square heart, a pure heart, just like Lord Pacal and Viracocha Pachacamac.

A longbow lay beside the body and a quiver for arrows containing bronze and iron arrowheads—all that was left of the arrows—hung from the backrest of the couch. This did not necessarily mean that he was a hunter but more likely referred to the fact that as a spiritual teacher, like Tutankhamun who is portrayed in his tomb paintings firing arrows and like the terracotta archers from the mausoleum of Ch'in Shi Huangdi, he 'aimed at the heart'; he came to purify the hearts of others. His birchbark conical cap rested on the end of the couch behind his head, making a halo fit for a king.

He was adorned with jewellery: a gold neckband, a gold bracelet and a 33-cm- (13-inch-) long, 8.5-cm (3-inch-) wide belt cover made from a band of sheet gold. A 42-cm (16-inch) bronze scabbard with a bronze cast wheel shape at the sharp end rested on the belt around his waist. The under-side of the scabbard was dulled with patina but the surface, covered in gold foil, shone brightly in the flashlights of the excavators. The scabbard sheath concealed an iron dagger topped

The Secrets of the Sun Shield of Monte Alban

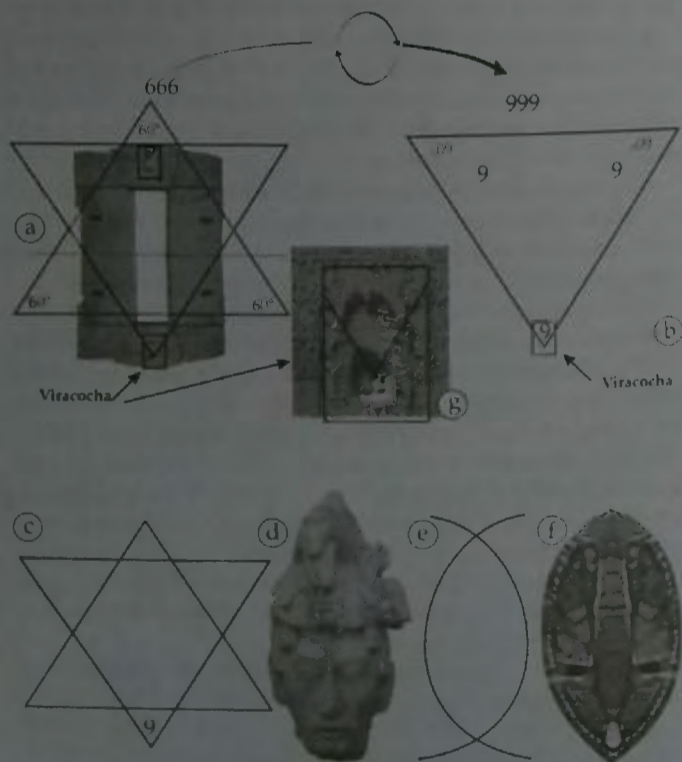

Figure 9. (a) Above and plate 2b show the decoded picture of a Star of David [the geometric symbol of Judaism] together with the Gateway of the Sun from Tiahuanaco, Bolivia. Note that the bas relief carving of Viracocha on the Gateway is positioned in the lower point of the star (b) corresponding to the number 9, meaning that Viracocha's number is 9, the number of a Supergod. (c) Plate 3c shows the decoded picture of a vesica pisces [the geometric symbol of Christianity] around the head and face of Lord Pacal. This reveals that Lord Pacal of Mexico (c. AD 750) and Viracocha (c. AD 500) were the same man as Jesus the Jew (c. AD 28)—different incarnations of Jesus on Earth. All three appear in decoded pictures from the sun shield of Monte Alban in a living miracle which shows the first pictures of Jesus. (d) In plate 5, Lord Pacal regurgitates a pearl. Regurgitation of a pearl (see main text) is a metaphor for the reincarnation of Venus (a Supergod) on Earth. Note the 66 pearls around the perimeter of Lord Pacal's head in (f). (g) The reason why the tip of the star forms the tongue of Viracocha is explained in Appendix 1.

the geometric symbol of Christianity which is derived from two overlapping circles (plate 3d) representing the various manifestations of Venus. The series of decoded pictures (figure 9) suggests that Judaism (represented by the star of David), Viracocha of Tiahuanaco and Lord Pacal, are all associated with Christianity (the vesica pisces). Plate 5 shows archaeological evidence from Central America to support the hypothesis. Moreover, the picture of Lord Pacal regurgitating a pearl (plate 3c) further suggests reincarnation and 'rebirth as Venus'.

We have already seen that Lord Pacal was Venus, Viracocha was Venus and Jesus was Venus. The inference must be that Jesus was born again as Viracocha and again as Lord Pacal. So here again we have 'the birth of Venus', just as we do with the Maya number 1,366,560.

By using the two similar figures, the true scientific figure of 1,366,040 to describe magnetic reversals that cause infertility cycles and cause Venus to flip upside down on its axis [that is, cause Venus to be reborn]—and another very close figure of 1,366,560—referred to as the 'birth of Venus' (because it amounts to 2,340 revolutions of Venus)—they were attempting to convey the fact that 'Venus is reborn'. They were trying to tell us that Jesus, who was the Sun on Earth (light) was reborn as Lord Pacal, he was 'the rebirth of Venus', the rebirth of Jesus. Maya transformers were just one of the living miracles that he left behind. Again, that this is the case is supported by more incredible composite pictures from the sun-shield of Monte Alban featured in plates 6–13 that show Lord Pacal as a stag, the birth of the baby Jesus, the adult life of Jesus, Jesus carrying the cross and Jesus dying on the cross. Plate 12 reveals the mechanism by which the Amazing Lid of Palenque can be decoded and plate 13 suggests that those who live by the body find only death whereas those of the 144,000 find eternal life.

The ancients believed that the Son of God has visited Earth on many occasions, as Krishna in India c. 1700 BC, as Tutankhamun c. 1353 BC; as Buddha c. 450 BC; as Ch'in Shi Huangdi c. 220 BC; as Jesus, as the legendary white Gods Viracocha Pachacamac [God of the World] c. AD 300 and Viracocha [foam of the sea] c. AD 500, who walked the lands of Peru performing miracles; and as Lord Pacal of the Maya, c. AD 750.

As Krishna says, during his discourse with the prodigy soldier Arjuna,

The Secrets of the Couch Caryatids



Figure 13. One of eight caryatids that support the bronze funeral couch of the King of Hochdorf. The raised arm stance resembles that of the small man who appears on the obelisk of Land Paol of Mexico, and the Viracochas of Peru (plates 5b and 5c). Like them, this man carries the mark of a pure heart on the chest, this time in the form of a square, a metaphor suggesting that the man being carried had a virtuous (pure) heart. He stands on the axle of the wheel that represents the Sun, that spins within him.

with a trident-shaped handle. [An iron dagger and a golden dagger were also found tucked into the waistband of Tutankhamun. There, the items explained that iron was more precious than gold because iron was magnetic and therefore enabled the owner to travel to far-off places and return again—using the magnetic compass—thus indicating spiritual leadership. The Tutankhamun iron dagger was the first appearance of iron known to man on Earth and thought to be of meteoric origin. The iron dagger in the gold-covered scabbard likely conveys the same principle.]

In the Hochdorf burial virtually every piece of gold, bronze, iron or fabric that could be decorated was adorned with solar circles, squares or reverse-swastika patterns.

What remained of his perished leather shoes was also embellished with gold foil, itself embossed with patterns of squares upon squares. It seemed that the foil pieces had been incorrectly fixed to the shoes, the right fixed in the position where the left should be and the left where the right should be, a metaphor suggesting that the next time the man would walk again would be in the spirit, as a soul (the mirror image of the body) in Heaven.

Next to the couch a sheet covered a large circular bronze cauldron trimmed with three bronze handles distributed around the rim. The three handles were interspersed with three cast bronze reclining lions or, more correctly, two reclining lions and one (seemingly poor) attempt at a lion casting. As though in error, it looks more like a sea-lion. The head and mane of the lion, from ancient times, referred to the face and rays of the Sun. Positioned around the rim of the cauldron it suggests that the spherical cauldron itself is also meant to represent the Sun. As though to emphasise the point a 13.4-cm- (5-inch-) diameter semi-spherical golden bowl embossed with patterns of circular sun-like discs was balanced between one defective lion, on the rim of the cauldron, and a good one. It is not clear why one lion was different from the other two or why the golden bowl was positioned as it was.

A magnificently ornate wooden four-wheeled carriage platform, decorated in iron sheeting, stood alongside the couch.²⁰ The corners of the carriage were held together by plates fixed with nine nails on either side (99, 99, 99, 99) like the coffin of Viracocha Pachacamac (figure A15). Onboard there were nine bronze plates, three bronze bowls,

THE CELTIC CHRONICLES

in the Bhagavad Gita, part of the epic Indian poem the Mahabharata:

Whenever spirituality decays and materialism is rampant, then, O Arjuna! I reincarnate myself'. (*The Gita*, Purohit Swami, Faber and Faber, 1982).

The Hallstatt Celts not only understood the super-science of the Sun but by featuring Venus so prominently in their carvings declared a preoccupation with, and a knowledge of, each of the world's religions past and present and in so doing reveal that they understood the higher orders of spirituality.

The Tomb of the King of Hochdorf

Renate Liebfried, the deputy for Monument Preservation in Baden-Wuerttemberg, in Germany was often called out to examine stones and timber ploughed-up on the ancient earth-covered barrow at Hochdorf. Eventually it became clear that a circular ring of logs, spaced at around three-metre intervals, had been buried vertically all around the 188-metre- (617-foot-) perimeter of the tumulus creating a hedge along the lines of Stonehenge-1 in England. In 1978, archaeologist Dr Joel Biel decided to excavate before any more of the tumulus was damaged from agricultural activity. The 6-metre- (19-foot 8 inches-) high mound was surrounded by a wide trench.

About a year after excavations began a central rubble-filled shaft, measuring 4.7 metres (15 feet 5 inches) square, began to emerge, running down through the centre of the mound. Digging continued down to around ground level when they hit what appeared to be a timber platform. Unsure as to what they might find they pressed on cautiously. Lifting the timbers, all they could see were fabrics draped on the walls and floor of a shallow chamber.

Entering the chamber they could only guess at what might lie below. Could this be the tomb of a 'Celtic Princess', like the one excavated in 1853 at the foot of the Celtic hill-fort at Mont Lassois, near Châtillon-sur-Seine in France, about 200 miles (322 km) west-south-west of where they were now digging? She was aged around 35 and estimated to be around 1.72 metres (5 feet 7 inches) tall. They found her laid out on a four-wheeled wooden wagon surrounded by all kinds of treasures, many

THE CELTS

The Tomb of the King of Hochdorf

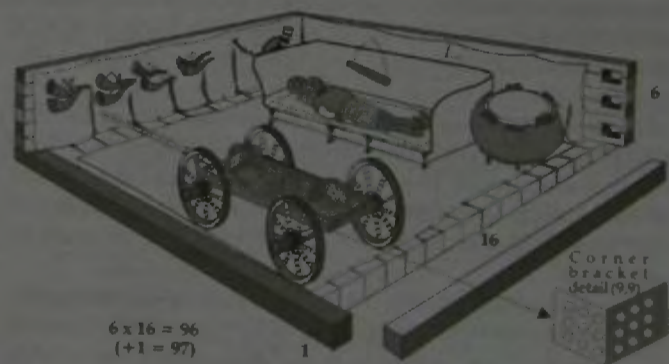

Figure 10. The Hochdorf tomb shares much in common with the tombs of other sun-worshipping kings. The Celts, like the Mayas, Peruvians, Egyptians and the ancient Chinese encoded the super-science of the Sun and the higher orders of spirituality into their treasures.

The Tomb Timbers of Viracocha Pachacamac

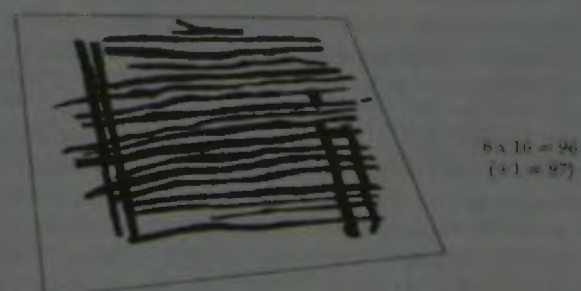

Figure 11. In wooden beams supported the roof of Viracocha Pachacamac's tomb. 5 T-shaped wooden beams supported these 3 x 3s not astronomically significant; however we note that one T-shaped beam was fixed on top of the roof (top centre, above). Why would tomb-builders place one of six supports on top of the roof? The message here is that how important, 6 x 16 = 96, the number of magnetic cycles in one sunspot cycle (figures A11, A12 and A13). One more transverse beam (figure A24) was embedded in the back, making a total of 97 but this did not appear to be intentional.

the remains of a wooden yoke, decorated with miniature bronze horse-shaped clips—to brace the horses—and a star-shaped bronze bridle arrangement made of six radiating chains (figure 14) held together by a central ring. Four of the chains consisted of seven circular rings (7, 7, 7, 7) whereas the other two contained only six circular rings (6, 6). Together these numerically refer to the rotation rates of the Sun's magnetic fields, 28 days and 41 days when measured from the moving Earth. The central larger ring carries a conical centre cap topped with a tiny sphere. The centre cone, capped with the Sun, clearly represents the polar magnetic cap of the Sun and with equal importance reveals that the conical birchbark hat worn by the dead man was a metaphor for the Sun confirming that he was, beneath the cap, the Sun itself and that his head was surrounded by light—a halo.

It took archaeologists two years to reconstruct the [approximately] 1,500 pieces of the carriage that was flattened under the weight of the crushing roof timbers. The engineering employed during its construction was of the highest order; two axles each carry two ten-spoked wooden wheels. The spokes of the wheels were mortised into oak hubs that turned on wooden roller bearings and each wheel is fitted with lath (wooden) tyres that are pinned to the individual wheels.

Many more golden discs, forming other parts of the equine head-gear, were piled on top of the carriage platform.

The inside of the backrest of the couch is carved with scenes of a man standing on a four-wheeled carriage. He holds a longbow, and a whip to control the two carriage horses—giving an idea of what the burial party wanted to convey to grave robbers unfamiliar with how the ancients preserved and encoded their secrets.

Many other smaller items were found in the tomb including five circular carved amber rings, ranging in size from around 2.5 cm (1 inch) to 1.2 cm (0.5 inch) in diameter, all positioned beside the neck of the dead man.

Amber, found prolifically in the Baltic where it is often washed ashore by the sea, is the fossilised resin from coniferous trees from the middle tertiary [65–1.65 million years ago] period. It was treasured and used in jewellery from as early as 35,000 BC because of its special ability to generate static electricity—a negative electrical charge—when rubbed with a cloth; hence the name *elektron*, the Greek word for amber.

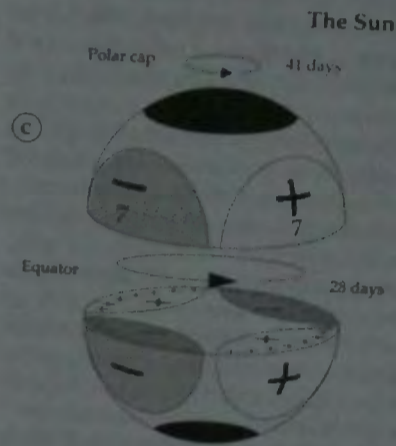
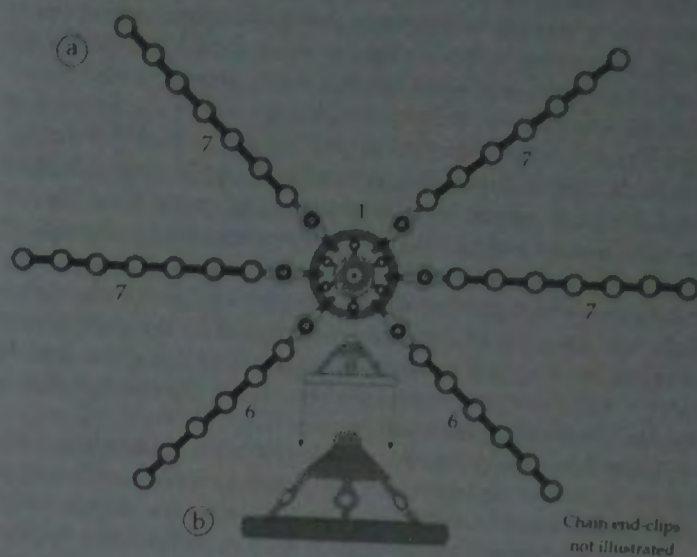

Figure 14 (a) The bridle arrangement is made of six chains; four chains of seven circular rings and two chains of six, all retained by one central larger ring that carries a cone-tier cone (b) which is capped by a tiny sphere. $4 \times 7 = 28$, the number of days for the Sun's equator to rotate once with respect to the moving Earth. (c) The magnetic polar cap of the Sun rotates more slowly; every 41 days $(4 \times 7) + (2 \times 6) + 1$ with respect to the moving Earth. The conical cap (b), illustrated here, is itself topped with a tiny sphere, suggesting that the cone represents the cap of the Sun. The conical cap shown here is the same shape as the birchbark hat (cap) worn by the man in the tomb, suggesting that the King of Hochdorf was the Sun (beneath the cap).

of Greek origin including a massive 1.65-metre- (5 feet 5 inches-) high bronze urn that could hold 500 litres (132 gallons) of honey-mead, 3 stone bracelets, a bronze bracelet with amber beads (on each wrist), 2 bronze anklets, amber and stone beads, bronze fibulae¹⁹ decorated with coral and amber, and iron and gold fibulae together with a magnificent gold torc weighing 0.5kg (1.1lb.). The word torc derives from the Latin torque, referring to a twisted piece of flattened metal that the early decorative collars resembled. They became more popular throughout Europe after the Hallstatt period and developed from a simple twisted strip of gold wrapped around the neck like an open hoop, to more ornate arrangements.

Their flashlights beamed into the dust-filled void below picking out a chamber 2.5 metres (8 feet 2 inches) deep and 7.4 metres (24 feet 3 inches) by 7.5 metres (23 feet 7 inches) wide, just below ground level. All they could see were woven and embroidered textiles and sheets draped around the walls and others, perhaps in bundles, on the floor.

Moments later the roof collapsed, crashing down into the space below, taking them with it. Soon it became clear, through the debris, that the chamber was constructed entirely of timbers (figure 10). The deck comprised of 16 short timbers and 1 longer end-timber, laid side by side. The walls were made of a stack of 6 longer-length timbers each carved with a mortise cavity to accommodate the tenon like transverse interlocking beams. The arrangement of beams seemed over-elaborate. Why would anyone go to so much trouble to build such a sophisticated structure?

The enigma of the elaborate timbers concealed the true purpose of the tomb and its contents; the numbers and lengths of beams crucially convey the numbers 96 and 97. Appendix 2 explains how and why the ancients preferred to use numbers to encode esoteric information into their treasures. Figure 12 shows the numbers and explains why they chose them. Here again, this time at Hochdorf, we begin to see the emergence of an ancient practice that uses the same numbers used by other sun worshipping civilizations in an attempt to convey the long lost knowledge of the Sun and the higher orders of spirituality.

The early Chinese were among the first to notice the periodic appearance of small black spots on the Sun's surface that manifest approximately

Encoding Information Using Numbers

1, 1 2, 2 3, 3
4, 4 5, 5 6, 6
7, 7 8, 8 9, 9

Numerical matrix often found in ancient tomb treasures to draw attention to the practice of encoding using numbers. Appendix 2 (figure A17) shows one example from the Pyramid of Inscriptions, Mexico.

Numbers used to encode esoteric spiritual knowledge

666 The Earth is carbon based. The Carbon atom comprises of 6 negative charges (electrons), 6 positive charges (protons) and 6 non charged particles (neutrons). The number appears in the Bible; here is wisdom, let him that hath understanding count the number of the beast; for it is the number of a man; and his name is sixes. (Revelation XIII, 18)

999 9 is the highest number that can be reached before becoming one with God (as in 10). 999 thus represents Heaven above God, the soul or a Supergod—a spiritual teacher. 666 represents the Earth being, Hell or the Devil. The purpose of life is to convert the body, 666, into Godly energy, 999.

144,000 Biblical number; refers to those destined for Heaven. 'I saw four angels standing on the four corners of the Earth holding the four winds of the Earth, that the wind should not blow on the Earth, nor on the sea, nor on any tree. And I saw another angel ascending from the east having the seal of the living God. And he cried with a loud voice to the four angels, to whom it was given to hurt the Earth, and the sea, saying 'Hurt not the Earth, neither the sea, nor the trees, till we have sealed the servants of our God in their foreheads. And I heard the number of them which were sealed; and there were sealed an hundred and forty-four thousand [144,000] of all the tribes of the children of Israel (Revelation VII, 14).

Numbers used to encode scientific knowledge—the super-science of the Sun

- 26 The time it takes, in days, for the Sun's equator to spin once on its axis.
- 28 The time it takes, in days, for the Sun's equator to spin once on its axis, viewed from the moving Earth.
- 37 The time it takes, in days, for the Sun's magnetic polar cap to spin once on its axis.
- 41 The time it takes, in days, for the Sun's magnetic polar cap to spin once on its axis, viewed from the moving Earth.
- 96 The number of solar magnetic cycles that subsist on the Sun every 187 years (made up of 16 observable 11.5-year (approximate) sunspot cycles (figure A11).
- 97 The number of solar magnetic cycles that need to be recognised when calculating the longer magnetic cycle of 18,139 years (figure A11).
- 20 The number of 187-year magnetic cycles that occur during 1 solar (total) sheet magnetic reversal of 3,740 years (1,366,040 days as calculated by computer).
- 1,366,040 The interval, in days, between solar magnetic reversals that cause Venus to physically flip on its axis (encoded into the sun shield of Monte Albán by the Maya (plate 2).
- 1,366,560 The Maya tracked the 1,366,040 interval using Venus; 3,340 revolutions of Venus (2,340 x 584) take 1,366,560 days, measured from the start date of their calendar in 3113 BC. They called the number 'the birth of Venus' but importantly, only as a metaphor to describe the spiritual rebirth of Venus—Lord Pacal was the rebirth of Venus (Jesus).

Figure 12

It is as though the five amber rings found next to the neck were placed out of position deliberately, rather than more appropriately alongside the bones of the five fingers—even though they are far too thick to have been used as ornamental finger rings. A similar conundrum was found in the tomb of Tutankhamun, where a cache of actual finger rings had been found out of position, on the floor of the tomb, as though discarded, threaded around a tubular piece of old cloth. There, the items amounted to an invitation to 'count' using the fingers. The anachronistic formation of amber rings next to the King of Hochdorf's neck might likewise be intended to convey the same information, an instruction to the observer to count the numerical attributes of the treasures in the tomb—the 6s, the 9s and so on—or, perhaps it amounted to a request to carefully *measure* the items in the tomb [a piece of thread wrapped around the base of the index finger five times stretches around the neck once].

Other small items recovered include gold snake-like fibulae around 6.5 cm (2.5 inches) long, some of which were used as hooks to hang fabrics from the walls together with three iron fishhooks, an iron fishing weight, a small quantity of fishing line and a small iron knife. Another iron knife was found in a wooden sheath. There was also a leather bag clasp with bronze pins and leather and bronze straps—that fitted to the horse yoke—sewing needles, bronze pins and nails, brooch parts and pendants, bone beads and slides, iron chains, an iron axe, a spear, a cleaver and horse bit (snaffle), a section of a deer antler and large quantities of woven fabrics.

This Hochdorf burial differed from other Celtic wagon tombs. The one at Mont Lassois containing the Celtic princess was less lavish and when analysed numerically contains none of the astronomical or spiritual numbers relating to esoteric tenets, unlike the tomb at Hochdorf or the tombs of other Supergods.

Moreover, the wheels of the funeral carriage at Hochdorf are the only four-wheeled ones that have been found attached to a wagon—as against others, like the wheels of the one at Mont Lassois that were found detached, resting against the tomb wall—and those of another wagon burial, at Mitterkirchen in upper Austria (northeast of Hallstatt) that likewise failed to yield any numerically significant information.

The evidence from the tomb at Hochdorf suggests that the occu-

every 11.5 years (figure 23b). 16 sunspot cycles subsist within every 187-year period. The same information was carved into a tablet by the Maya at their ceremonial site of Palenque, c. AD 750 (figure A12), encoded into the tomb design of Tutankhamun, c. AD 1353 (figure A13), and encoded into the tomb timbers of Viracocha Pachacamac in Peru, c. AD 300 (figures 11 and A14). These revelations, together with the fact that the central shaft running down through the tumulus was exactly square (4.7 metres (15 feet 5 inches)), announce that the tomb designer was both aware of the sunspot cycle (the super-science of the Sun) and was also 'on the square', a virtuous man who was aware of the higher orders of spirituality. This had to be the tomb of a long-lost Supergod.

Removal of the sheeting used to wrap much of the contents of the tomb revealed what archaeologists described as the remains of an ancient 'Celtic Prince'. His bones were those of a Caucasian 1.87 metres (6 feet 1-inch-) tall who was aged about 45 years old when he died in around 550 BC.

He was wrapped in several woven blankets that were decorated with reverse-swastika patterns, identifying him with the planet Venus. At one end of the chamber 8 organic drinking-horns hung from the wall in pairs alongside another larger more decorative 9-section iron horn. That one appears to have a mouthpiece, plugged by a detachable stopper, and could therefore have been used as a sounding-horn. The ornate stopper consists of a slim tapering tube. A solar-style convex disc sits on the end, like an open umbrella, and a tiny white bead, fastened to the centre of the disc, terminates the end of the horn. What appear to be two identical tiny cast characters kneel either side of the tube with their arms raised as though worshipping the sun-disc at the end.

The King lay on his back on a 3-metre (9 foot-) long bronze funerary couch, made of 6 riveted bronze sheets, supported by eight caryatids (figure 13) adopting the raised-arm stance of the two sun worshippers found on the end of the iron horn (and similar characters found in the tombs of Lord Pacal and the Viracochas' (plates 5b and 5c)). Whether the figures are truly (female) caryatids, or male, is not clear. In any event, the figure on the right was the ninth (9th) occupant of the couch, just as Viracocha Pachacamac was the 9th occupant of his tomb (figure A14). Each of the caryatids stand *entirely* on the axle of a bronze wheel

pant was, like Tutankhamun, Ch'in Shi Huangdi, the Viracochas and Lord Pacal, a Supergod leader of the Celts who lived in Hochdorf in around 550 BC.

Celtic Trade

In Europe, the Bronze Age subsisted from around 2000 to 800 BC.²¹ Bronze is an alloy of copper (typically 75%) and tin (25%). The addition of tin makes the resulting alloy much harder than copper, corrosion resistant and ideal for casting. Thus it became the preferred metal for weapons, tools, vessels and artworks until the more plentiful iron was first smelted in Europe during the early Hallstatt period where swords, scabbards and daggers and other items made of iron were found in grave sites.

In around 600 BC the Greeks, who controlled the Mediterranean, enjoyed a plentiful supply of tin from mines in Cornwall, England, to facilitate the manufacture of bronze and bronze goods throughout the Greek Empire. Tin shipments crossed the Bay of Biscay southwards, through the Straits of Gibraltar and onwards to Greece.

Gaulish [French] Celts imported their own supplies from across the Channel up the River Seine into the Celtic heartland of Europe (figure 15) establishing hill-forts at Mont Lassois, at the end of the River Seine, and farther south at Camp de Chassey, to provide a safe and secure environment for the transfer of cargoes and to accommodate the movement of gold and goods bartered for payment. In turn, wealthy Celtic merchants used the gold to purchase goods from Greek markets in the south of France. As a result, a boom in trade occurred and as a consequence the Greeks developed the trading port of Massalia, modern-day Marseilles, in the south of France. Greek goods were shipped north from Massalia to the Celts in France and Germany and also to sites in Austria and Switzerland to compete with Etruscan goods arriving from established trade routes from Italy through the Alpine passes. They were also transhipped overland between hill-forts to the Seine and across the English Channel to Cornwall. The hill-forts became the crossroads of inter-European trade.

In turn the Greeks traded ivory from Africa; wine from the vineyards in the south; ceramics and dyes (used in fabrics) that the Celts

The Secrets of the Couch Caryatids



Figure 13 One of eight caryatids that support the bronze funerary couch of the King of Hochdorf. The raised arm stance resembles that of the small man who appears in the tombs of Lord Pacal, of Mexico, and the Viracochas' of Peru (plate 5b and 5c). Like them, this one carries the mark of a pure heart on the chest, this time in the form of a square, a metaphor suggesting that the man being carried had a virtuous (pure) heart. He stands on the axle of the wheel that represents the Sun, that spins within him.

Euro-Celtic Hill Forts c. 580-480 BC

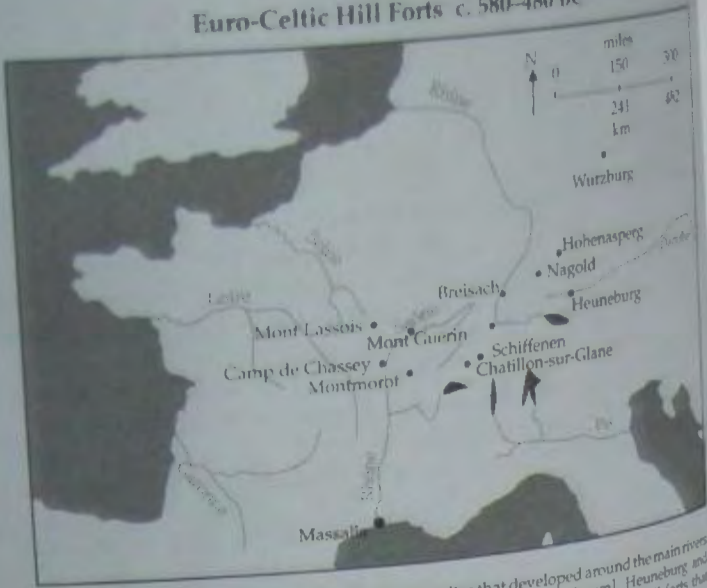

Figure 15. Map showing the principal Celtic trading sites that developed around the main rivers of Europe between c. 580 and 480 BC (not all rivers and sites are shown). Heuneburg and Hohenasperg in Germany and Mont Lassois in France were the largest of the hill-forts that accommodated the transshipment of goods from Europe to the Mediterranean.

exchanged for woven textiles, gold, silver and iron. The large Greek bronze cauldron found in the tomb at Hochdorf and the massive Greek bronze cauldron and drinking vessels found in the tomb at Mont Lassois testify to the trade at the time.

Excavated hill-fort sites frequently contain workshops of bronze-, silver- and goldsmiths suggesting that they were indeed secure trading posts established to accommodate the safe transshipment of goods from the time they appeared in around 580 BC to the time they were simultaneously abandoned in around 480 BC.

Although the Euro-Celts began to drift westwards into Britain and Ireland as early as 800 BC, it is likely that the period between 580 and 480 BC, coinciding with the boom in Euro trade, witnessed the heaviest migrations. Copies of French Celtic hill-forts began to appear in Britain from around 580 BC; the remains of one, the Ivinghoe Beacon,

excavated in 2002 in Buckinghamshire, England, is believed to have been constructed in a similar way to the one at Mont Lassois.

The reason for the collapse of the Celtic hill-forts on the European mainland in around 480 BC is not clear and remains a matter of speculation. It could be that the Celts eventually gained a monopoly in tin, forcing the price upwards, which in turn accelerated the introduction and use of iron. Or perhaps the appearance of iron reduced the demand for bronze and hence tin, not only by the Celts but also by the Greeks. Whatever the reason, it marked the end of the Hallstatt D period sites at: Mont Lassois, Camp de Chassey, Mont Guerin and Montmorot in France; Breisach, Nagold and Hohenasperg in Germany; and Schiffenen and Chatillon-sur-Glane in Switzerland, and the beginning of the La Tène period of Celtic archaeology.

Glauberg

Of all of the Euro-Celtic archaeological sites, one located just south of Hochdorf dating to around the same period (c. 500 BC) deserves a mention here. The Glauberg site, 32 km (19.9 miles) northeast of Frankfurt, was located from the air in 1987. Excavation of the 50-metre- (164-foot-) diameter tumulus (figure 16a) surrounded by a 70-metre- (230-foot-) diameter trench began in 1996. A chamber located in the centre of the mound was found empty. Two burials excavated between 1998 and 2001 were found either side of the central chamber. Grave number 1 revealed a 2.25 m x 1.07 m x 1-metre-high (7 feet 5 inches x 3 feet 6 inches x 3 feet 3 inches) timber coffin containing cremated human remains together with burial goods typical of the period, including a bronze jar-like flagon, two groups of bronze buttons, a bronze brooch, a belt (with a bronze belt hook, fastening clasp, hole rings, small chain and ornamental rivets), an iron sword with a bronze and iron sheath, iron spearheads and iron arrowheads.

Grave 2 contained the remains of human bones, three wooden spears with iron spearheads, a leather quiver with three iron-headed arrows, a longbow, a wooden shield—with an iron frame—two gold earrings, a 21.5-cm- (8-inch-) long gold necklace, a belt (with a bronze belt hook, small chain, hole rings and ornamental rivets), two bronze rings, one golden bracelet, one gold finger ring, an iron sword with

decorated with red coral disc incrustations, emulating sunspots, suggesting that the dead man was preoccupied with the spinning Sun on its axis. The chest of each caryatid is pierced with a square stud, meaning that the man they carried, above, had a square heart, a pure heart, just like Lord Pacal and Viracocha Pachacamac.

A long-bow lay beside the body and a quiver for arrows containing bronze and iron arrow heads—all that was left of the arrows—hung from the backrest of the couch. This did not necessarily mean that he was a hunter but more likely referred to the fact that as a spiritual teacher, like Tutankhamun who is portrayed in his tomb paintings firing arrows and like the *tepetzotla* archers from the mausoleum of Ch'in Shi Huangdi, he 'aimed at the heart', he came to purify the hearts of others. His birch bark conical hat rested on the end of the couch behind his head, making a vain fit for a king.

He was adorned with jewellery: a gold neckband, a gold bracelet and a 33cm- (13-inch-) long, 0.5cm (3/16-inch-) wide belt cover made from a band of sheet gold. A 4cm- (1 1/2-inch-) bronze scabbard with a bronze cast wheel shape at the sharp end rested on the belt around his waist. The underside of the scabbard was drilled with patina but the surface, covered in gold foil, shone brightly in the flashlights of the excavators. The scabbard sheath concealed an iron dagger topped with a trident shaped handle. An iron dagger and a golden dagger were also found tucked into the waistband of Tutankhamun. Thus, the items explained that iron was more precious than gold because iron was magnetic and therefore enabled the owner to travel to far-off places and return again—using the magnetic compass—thus indicating spiritual leadership. The Tutankhamun iron dagger was the first appearance of iron known to man on Earth and thought to be of meteoric origin. The iron dagger in the gold-covered scabbard likely conveys the same principle.

In the Hochdorf burial virtually every piece of gold, bronze, iron or silver that could be decorated was adorned with solar circles, squares of *reversé-wawilka* patterns.

What remained of his perished leather shoes was also embellished with gold foil, itself embossed with patterns of squares upon squares. It seemed that the last pieces had been meticulously fixed to the shoes, the right fixed in the position where the left should be and the left where the

right should be; a metaphor suggesting that the next time the man would walk again would be in the spirit, as a soul (the mirror image of the body) in Heaven.

Next to the couch a sheet covered a large circular bronze cauldron trimmed with three bronze handles distributed around the rim. The three handles were interspersed with three cast bronze reclining lions or, more correctly, two reclining lions and one (seemingly poor) attempt at a lion casting. As though in error, it looks more like a sea-lion. The head and mane of the lion, from ancient times, referred to the face and rays of the Sun. Positioned around the rim of the cauldron it suggests that the spherical cauldron itself is also meant to represent the Sun. As though to emphasise the point a 13.4cm- (5-inch-) diameter semispherical golden bowl embossed with patterns of circular sun-like discs, was balanced between one defective lion, on the rim of the cauldron, and a good one. It is not clear why one lion was different to the other two or why the golden bowl was positioned as it was.

A magnificently ornate wooden four-wheeled platform-carriage, decorated in iron sheeting, stood²⁰ alongside the couch. The corners of the carriage were held together by plates fixed with 9 nails on either side (99, 99, 99, 99) like the coffin of Viracocha Pachacamac (figure A15). Onboard there were 9 bronze plates, three bronze bowls, the remains of a wooden yoke, decorated with miniature bronze horse-shaped clips—to brace the horses, and a star-shaped bronze bridle arrangement made of 6 radiating chains (figure 14) held together by a central ring. Four of the chains comprised of 7 circular rings (7, 7, 7, 7) whereas the other two contained only 6 circular rings (6, 6). Together these numerically refer to the rotation rates of the Sun's magnetic fields, 28 days and 41 days when measured from the moving Earth. The central larger ring carries a conical centre cap topped with a tiny sphere. The centre-cone, capped with the Sun, clearly represents the Polar magnetic Cap of the Sun and with equal importance reveals that the conical birch bark hat worn by the dead man was a metaphor for the Sun confirming that he was, beneath the cap, the Sun itself and that his head was surrounded by light—a halo.

It took archaeologists two years to reconstruct the [approximately] 1,500 pieces of the carriage that was flattened under the weight of the crush-

One of the most amazing books I have ever read... affect the future of us all... Colin Wilson, bestselling author of *The Cosmic*... (see photograph by M. J. ...)

the remains of a wooden yoke, decorated with miniature bronze horse-shaped clips—to brace the horses—and a star-shaped bronze bridle arrangement made of six radiating chains (figure 14) held together by a central ring. Four of the chains consisted of seven circular rings (6, 6, 7, 7, 7) whereas the other two contained only six circular rings (6, 6). Together these numerically refer to the rotation rates of the Sun's magnetic fields, 28 days and 41 days when measured from the moving Earth. The central larger ring carries a conical centre cap topped with a tiny sphere. The centre cone, capped with the Sun, clearly represents the polar magnetic cap of the Sun and with equal importance reveals for the Sun confirming that he was, beneath the cap, the Sun itself and that his head was surrounded by light—a halo.

It took archaeologists two years to reconstruct the [approximately] 1,500 pieces of the carriage that was flattened under the weight of the crushing roof timbers. The engineering employed during its construction was of the highest order; two axles each carry two ten-spoked wooden wheels. The spokes of the wheels were mortised into oak hubs that turned on wooden roller bearings and each wheel is fitted with lath (wooden) tyres that are pinned to the individual wheels.

Many more golden discs, forming other parts of the equine headgear, were piled on top of the carriage platform. The inside of the backrest of the couch is carved with scenes of a man standing on a four-wheeled carriage. He holds a longbow, and a whip to control the two carriage horses—giving an idea of what the burial party wanted to convey to grave robbers unfamiliar with how the ancients preserved and encoded their secrets.

Many other smaller items were found in the tomb including five circular carved amber rings, ranging in size from around 2.5 cm (1 inch) to 1.2 cm (0.5 inch) in diameter, all positioned beside the neck of the dead man.

Amber, found prolifically in the Baltic where it is often washed ashore by the sea, is the fossilised resin from coniferous trees from the middle tertiary [65–1.65 million years ago] period. It was treasured and used in jewellery from as early as 35,000 BC because of its special ability to generate static electricity—a negative electrical charge—when rubbed with a cloth; hence the name *elektron*, the Greek word for amber.

The Secrets of the Bridle

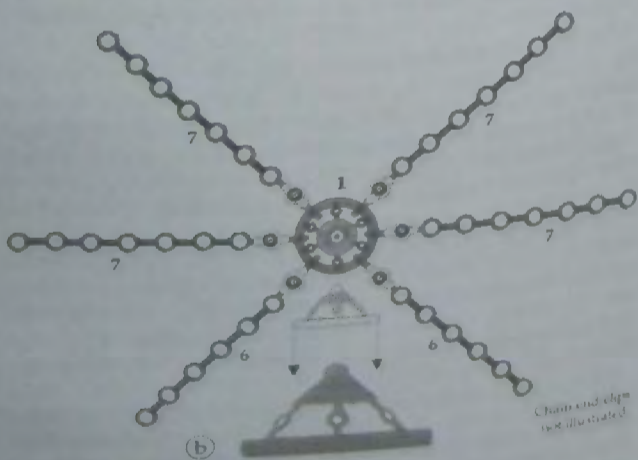

The Sun

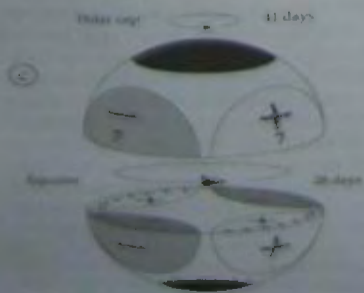

Figure 14. (a) The bridle arrangement is made of six chains, four chains of 7 circular rings and two chains of 6, all retained by one central larger ring that carries a nine-tier cone topped with a tiny sphere. (b) The number of days for the Sun's equator to rotate once is 28, the number of days for the Sun's polar cap to rotate once is 41. The magnetic polar cap of the Sun rotates more slowly, every $(2 \times 6) + 1$ with respect to the moving Earth. The conical cap shown here is the same shape as the birchbark hat (cap) worn by the man in the tomb, suggesting that the King of Hochdorf was the Sun (beneath the cap).

The Secrets of the Bridle

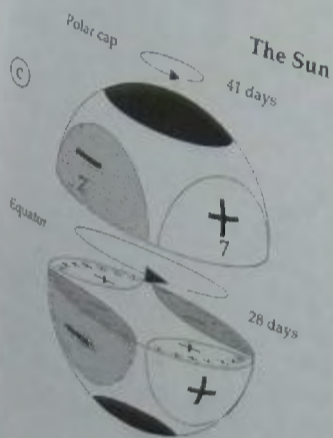
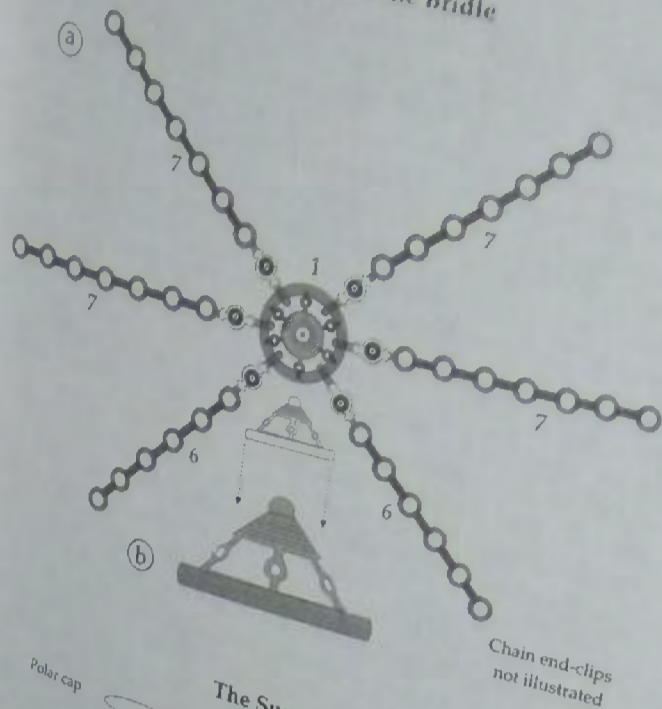
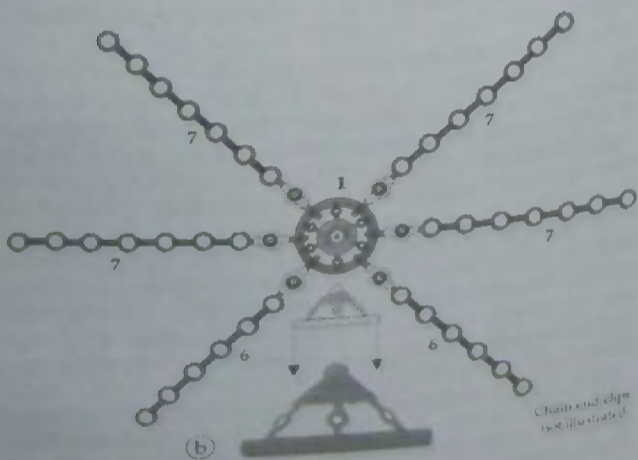

Figure 14. (a) The bridle arrangement is made of six chains, four chains of 7 circular rings and two chains of 6, all retained by one central larger ring that carries a nine-tier cone topped with a tiny sphere. (b) The number of days for the Sun's equator to rotate once with respect to the moving Earth. (c) The magnetic polar cap of the Sun rotates more slowly, every 41 days $((4 \times 7) + 1)$ with respect to the moving Earth. The conical cap shown here is the same shape as the birchbark hat (cap) worn by the man in the tomb, suggesting that the King of Hochdorf was the Sun (beneath the cap).

The Secrets of the Bridle



The Sun

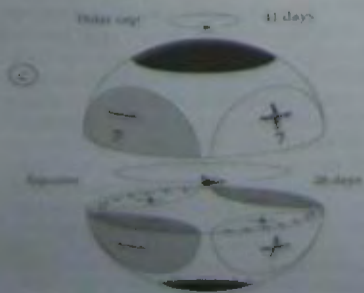

Figure 14. (a) The bridle arrangement is made of six chains, four chains of 7 circular rings and two chains of 6, all retained by one central larger ring that carries a nine-tier cone topped with a tiny sphere. (b) The number of days for the Sun's equator to rotate once is 28, the number of days for the Sun's polar cap to rotate once is 41. The magnetic polar cap of the Sun rotates more slowly, every $(2 \times 6) + 1$ with respect to the moving Earth. The conical cap shown here is the same shape as the birchbark hat (cap) worn by the man in the tomb, suggesting that the King of Hochdorf was the Sun (beneath the cap).

ing roof timbers. The... of the highest order; two axles... The spokes of the wheels were mortised... wooden roller bearings and each wheel is fitted with... that are pinned to the individual wheels. Many more golden discs, forming other parts of the equine headgear, were piled on top of the carriage platform.

The inside of the backrest of the couch is carved with scenes of a man standing on a four-wheeled carriage. He holds a longbow, and a whip to control the two carriage horses—giving an idea of what the burial party wanted to convey to grave robbers unfamiliar with how the ancients preserved and encoded their secrets.

Many other smaller items were found in the tomb including five circular carved amber rings, ranging in size from around (2.5cm) 1-inch to 1.2cm (0.5-inch) in diameter, all positioned beside the neck of the dead man.

Amber, found prolifically in the Baltic where it is often washed ashore by the sea, is the fossilised resin from coniferous trees from the middle tertiary [65–1.65 million years ago] period. It was treasured and used in jewellery from as early as 35,000 BC because of its special ability to generate static electricity—a negative electrical charge—when rubbed with a cloth; hence the name *elektron*, the Greek word for amber.

It is as though the five amber rings found next to the neck were placed out of position deliberately, rather than more appropriately alongside the bones of the five fingers—even though they are far too thick to have been used as ornamental finger-rings. A similar conundrum was found in the tomb of Tutankhamun where a cache of actual finger-rings had been found out of position, on the floor of the tomb, as though discarded, threaded around a tubular piece of old cloth. There, the items amounted to an invitation to 'count' using the fingers. The anachronistic formation of amber rings next to the King of Hochdorf's neck might likewise be intended to convey the same information, an instruction to the observer to count the numerical attributes of the treasures in the tomb—the five, the five and to on—or, perhaps it amounted to a request to carefully measure the items in the tomb [a piece of thread wrapped around the base of the index finger 5 times stretches around the neck once].

The Glauberg Tumulus

Figure 16. (a) The tumulus at Glauberg was discovered in 1987 and has been under excavation since 1996. Two graves were found together with burial treasures and a magnificent sandstone statue that was given the name 'the Celtic Prince' (b).

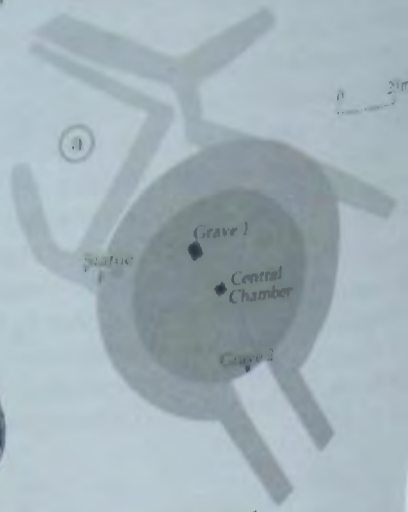

The Bat God



(b) Sketch of 1.82-metre (6-foot), 227-kg (500-lb) statue c. 500 BC, excavated at Glauberg in 1996. Appendage and markings on the forehead, triple neck pendants and massive ears suggest that the statue represents the Bat God. (c) The bat god represented death in many cultures. This from the Olmec, in Central America, onwards. This twenty-five-piece jade figure, found in a tomb at Monte Alban, Mexico, dates from around AD 700.

a bronze scabbard, six small wooden rods with iron spouts, a bronze brooch, fragments of bronze rings, three small iron rivets, two bronze bird-headed brooches and a 52.2-cm- (20-inch-) tall highly decorated bronze flagon.

These followed on from the 1996 discovery of a 1.86-metre- (6-foot 1-inch-) tall sandstone statue found in a wide trench west of the tomb (figure 16b). The excavators, unsure how to describe the highly unusual sculpture, labelled it 'a Celtic Prince'. But such an unusual-looking prince would be hard to find; his unique appearance with his more closely as a representation of the Bat God, worshipped throughout Central America as the god of death. This is not the first time the Bat God has been found in Hallstatt period excavations; the head of another so-called Celtic Prince, identical to this one, was found in Heidelberg, which is an interesting and unusual discovery, because it means that the sun-worshipping Celts shared the same mythological beliefs of the Maya. That this is the case is further supported by the appearance of stag and snake carvings found prolifically on the swords, scabbards, flagons and jewellery in the two graves at Glauberg.

The stag is a solar symbol known to have been worshipped by other sun-worshipping civilizations; it sheds its antlers at yearly intervals—and the Earth orbits the Sun at yearly intervals. It is also closely associated with fertility—because the Sun's radiation regulates fertility on Earth. And because grass contains high amounts of cellulose, making it difficult to digest, it is a ruminator (it regurgitates food already swallowed, to chew again [up to four times]), associating the stag with the notion of regurgitation [as in the case of regurgitation of a pearl in plate 3c] and reincarnation of the human soul on Earth.

- God is light, therefore God is the Sun and Jesus (as the Son of God) is therefore the Sun incarnate on Earth. This is to say that Jesus is the Sun and the stag is the Sun, so Jesus is the stag (figures 17 and 18).
- Jesus is also known to have healed the sick with his bare hands, which is why pharmacies in France and Germany often carry the picture of a stag above the door. One example is the Pharmacy

THE CELTIC CHRONICLES

Other small items recovered include gold snake-like fibulae around 6.5cm (2.5 inches) long, some of which were used as hooks to hang fabrics from the walls together with three iron fish hooks, an iron fishing weight, a small quantity of fishing line and a small iron knife. Another iron knife was found in a wooden sheath. There was also a leather bag clasp with bronze pins and leather and bronze straps—that fitted to the horse yoke—sewing needles, bronze pins and nails, brooch parts and pendants, bone beads and slides, iron chains, an iron axe, a spear, a cleaver and horse bit (snaffle), a section of a deer antler and large quantities of woven fabrics.

This Hochdorf burial differed from other Celtic wagon tombs. The one at Mont Lassois containing the Celtic princess was less lavish and when analysed numerically, contains none of the astronomical or spiritual numbers relating to esoteric tenets, unlike the tomb at Hochdorf or the tombs of other Supergods.

Moreover, the wheels of the funeral carriage at Hochdorf are the only four-wheeled ones that have been found attached to a wagon—as against others, like the wheels of the one at Mount Lassois that were found detached, resting against the tomb wall—and those of another wagon burial, at Mitterkirchen in upper Austria (north-east of Hallstatt) that likewise failed to yield any numerically significant information.

The evidence from the tomb at Hochdorf suggests that the occupant was, like Tutankhamun, Ch'in Shi Huangdi, the Viracochas and Lord Pacal, a Supergod leader of the Celts who lived in Hochdorf in around 550 BC.

Celtic Trade

In Europe, the Bronze Age²¹ subsisted from around 2000–800 BC. Bronze is an alloy of Copper (typically 75%) and Tin (25%). The addition of tin makes the resulting alloy much harder than copper, corrosion resistant and ideal for casting. Thus it became the preferred metal for weapons, tools, vessels and artworks until the more plentiful iron was first smelted in Europe during the early Hallstatt period where swords, scabbards and daggers and other items made of iron were found in grave sites.

In around 600 BC, the Greeks, who controlled the Mediterranean, enjoyed a plentiful supply of tin from mines in Cornwall, England, to facilitate

THE CELTS

Euro-Celtic Hill-forts c. 580–480 BC

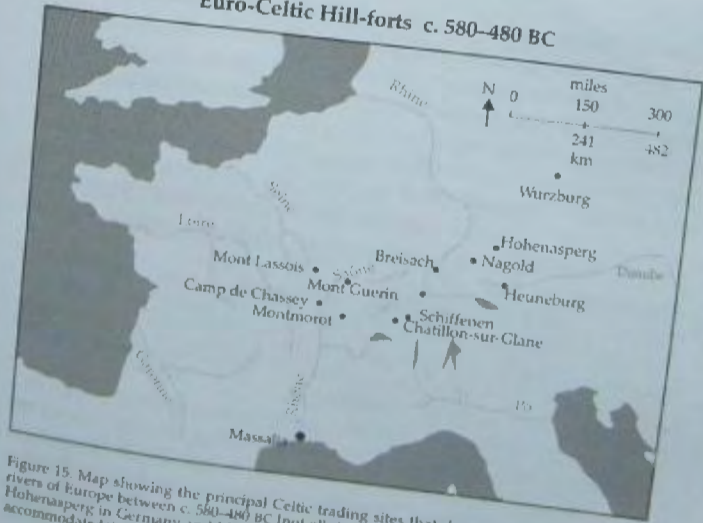
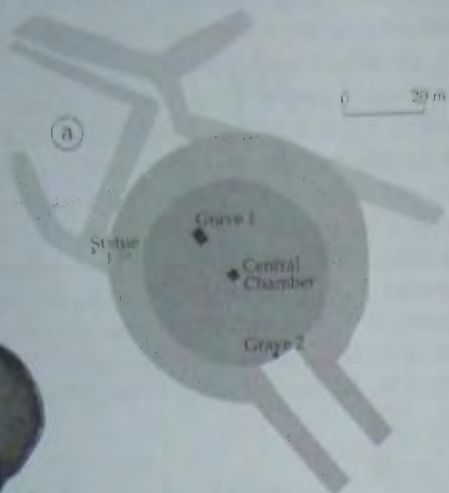

Figure 15. Map showing the principal Celtic trading sites that developed around the main rivers of Europe between c. 580–480 BC (not all rivers and sites are shown). Heuneburg and Hohenasperg in Germany and Mont Lassois in France were the largest of the hill-forts that accommodated the transshipment of goods from Europe to the Mediterranean.

tate the manufacture of bronze and bronze goods throughout the Greek Empire. Tin shipments crossed the Bay of Biscay southwards, through the Straits of Gibraltar and onwards to Greece. Gaulish [French] Celts imported their own supplies from across the Channel up the River Seine into the Celtic heartland of Europe (figure 15) establishing hill-forts at Mont Lassois, at the end of the River Seine, and further south at Camp de Chassey, to provide a safe and secure environment for the transfer of cargoes and to accommodate the movement of gold and goods bartered for payment. In turn, wealthy Celtic merchants used the Gold to purchase goods from Greek markets in the south of France. As a result a boom in trade occurred and as a consequence the Greeks developed the trading port of Massalia, modern-day Marseilles, in the south of France. Greek goods were shipped north from Massalia to the Celts in France and Germany and also to sites in Austria and Switzer-

The Glauberg Tumulus

Figure 16 (a) The tumulus at Glauberg was discovered in 1987 and has been under excavation since 1996. Two graves were found together with burial treasures and a magnificent sandstone statue that was given the name 'The Celtic Prince' (b).



The Bat God



(b) Sketch of 1.82-metre (6-foot), 227-kg (500-lb) statue c. 500 BC, excavated at Glauberg in 1996. Appendage markings on the forehead, triple neck pendants and massive ears suggest that the statue represents the Bat God. (c) The bat god represented death in many cultures from the Olmec, in Central America, onwards. This twenty-five-piece jade figure, found in a tomb at Monte Alban, Mexico, dates from around AD 700.

a bronze scabbard, six small wooden rods with iron spouts, a bronze brooch, fragments of bronze rings, three small iron rivets, two bronze bird-headed brooches and a 52.2-cm- (20-inch-) tall highly decorated bronze flagon.

These followed on from the 1996 discovery of a 1.86-metre- (6-foot 1-inch-) tall sandstone statue found in a wide trench west of the tomb (figure 16b). The excavators, unsure how to describe the highly unusual sculpture, labelled it 'a Celtic Prince'. But such an unusual-looking prince would be hard to find; his unique appearance with his massive ears, forehead appendage and triple neck-drops identify him more closely as a representation of the Bat God, worshipped throughout Central America as the god of death. This is not the first time the Bat God has been found in Hallstatt period excavations; the head of another so-called Celtic Prince, identical to this one, was found in Heidelberg, which is an interesting and unusual discovery, because it means that the sun-worshipping Celts shared the same mythological beliefs of the Maya. That this is the case is further supported by the appearance of stag and snake carvings found prolifically on the swords, scabbards, flagons and jewellery in the two graves at Glauberg.

The stag is a solar symbol known to have been worshipped by other sun-worshipping civilizations; it sheds its antlers at yearly intervals—and the Earth orbits the Sun at yearly intervals. It is also closely associated with fertility—because the Sun's radiation regulates fertility on Earth. And because grass contains high amounts of cellulose, making it difficult to digest, it is a ruminator (it regurgitates food already swallowed, to chew again [up to four times]), associating the stag with the notion of regurgitation [as in the case of regurgitation of a pearl in plate 3c] and reincarnation of the human soul on Earth.

And, stag-like associations do not end there:

- God is light, therefore God is the Sun and Jesus (as the Son of God) is therefore the Sun incarnate on Earth. This is to say that Jesus is the Sun and the stag is the Sun, so Jesus is the stag (figures 17 and 18).
- Jesus is also known to have healed the sick with his bare hands, which is why pharmacies in France and Germany often carry the picture of a stag above the door. One example is the Pharmacy

33

THE CELTIC CHRONICLES

Other small items recovered include gold snake-like fibulae around 6.5cm (2.5 inches) long, some of which were used as hooks to hang fabrics from the walls together with three iron fish hooks, an iron fishing weight, a small quantity of fishing line and a small iron knife. Another iron knife was found in a wooden sheath. There was also a leather bag clasp with bronze pins and leather and bronze straps—that fitted to the horse yoke—sewing needles, bronze pins and nails, brooch parts and pendants, bone beads and slides, iron chains, an iron axe, a spear, a cleaver and horse bit (snaffle), a section of a deer antler and large quantities of woven fabrics.

This Hochdorf burial differed from other Celtic wagon tombs. The one at Mont Lassois containing the Celtic princess was less lavish and when analysed numerically, contains none of the astronomical or spiritual numbers relating to esoteric tenets, unlike the tomb at Hochdorf or the tombs of other Supergods.

Moreover, the wheels of the funeral carriage at Hochdorf are the only four-wheeled ones that have been found attached to a wagon—as against others, like the wheels of the one at Mount Lassois that were found detached, resting against the tomb wall—and those of another wagon burial, at Mitterkirchen in upper Austria (north-east of Hallstatt) that likewise failed to yield any numerically significant information.

The evidence from the tomb at Hochdorf suggests that the occupant was, like Tutankhamun, Ch'in Shi Huangdi, the Viracochas and Lord Parac, a Supergod leader of the Celts who lived in Hochdorf in around 550 BC.

Celtic Trade

In Europe, the Bronze Age²¹ subsisted from around 2000–800 BC. Bronze is an alloy of Copper (typically 75%) and Tin (25%). The addition of tin makes the resulting alloy much harder than copper, corrosion resistant and ideal for casting. Thus it became the preferred metal for weapons, tools, vessels and artworks until the more plentiful iron was first smelted in Europe during the early Hallstatt period where swords, scabbards and daggers and other items made of iron were found in grave sites.

In around 600 BC the Greeks, who controlled the Mediterranean, enjoyed a plentiful supply of tin from mines in Cornwall, England, to facili-

THE CELTS

Euro-Celtic Hill-forts c. 580–480 BC

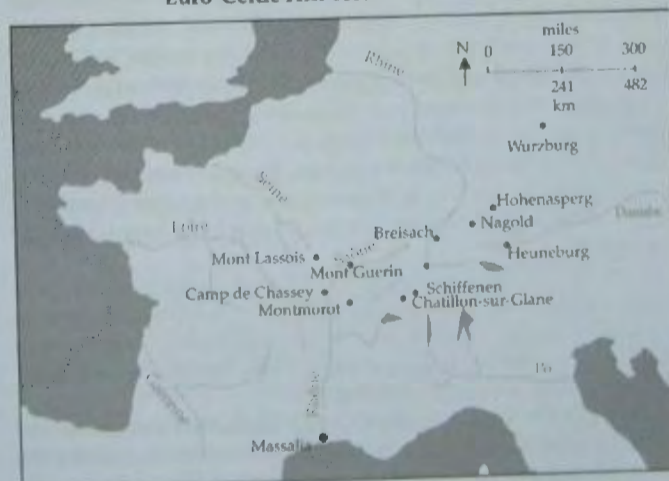

Figure 15. Map showing the principal Celtic trading sites that developed around the main rivers of Europe between c. 580–480 BC [not all rivers and sites are shown]. Heuneburg and Hohenasperg in Germany and Mont Lassois in France were the largest of the hill-forts that accommodated the transshipment of goods from Europe to the Mediterranean.

tate the manufacture of bronze and bronze goods throughout the Greek Empire. Tin shipments crossed the Bay of Biscay southwards, through the Straits of Gibraltar and onwards to Greece.

Gaulish [French] Celts imported their own supplies from across the Channel up the River Seine into the Celtic heartland of Europe (figure 15) establishing hill-forts at Mont Lassois, at the end of the River Seine, and further south at Camp de Chassey, to provide a safe and secure environment for the transfer of cargoes and to accommodate the movement of gold and goods bartered for payment. In turn, wealthy Celtic merchants used the Gold to purchase goods from Greek markets in the south of France. As a result a boom in trade occurred and as a consequence the Greeks developed the trading port of Massalia, modern-day Marseilles, in the south of France. Greek goods were shipped north from Massalia to the Celts in France and Germany and also to sites in Austria and Switzer-

The Stag, the Sun and the Cross

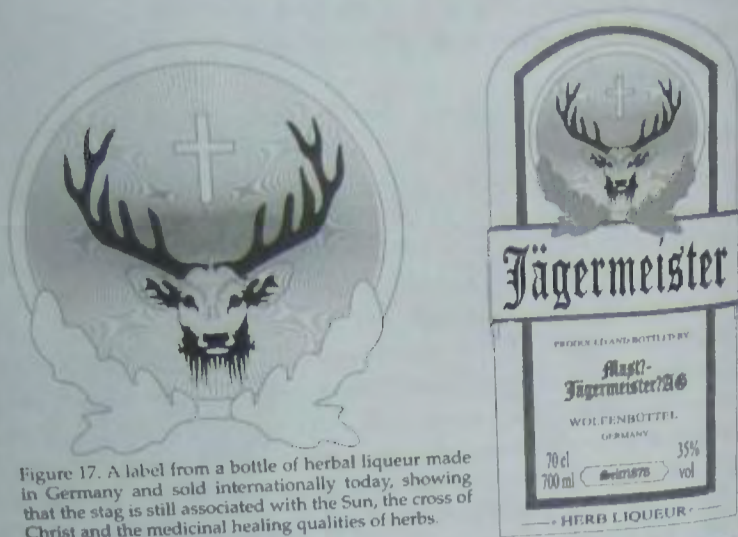

Figure 17. A label from a bottle of herbal liqueur made in Germany and sold internationally today, showing that the stag is still associated with the Sun, the cross of Christ and the medicinal healing qualities of herbs.

The Stag, the Antlers and the Crown of Thorns



Figure 18 (a) Thorn sprigs. (b) Roman soldiers preparing Jesus with a crown of thorns in readiness for execution.



34

THE CELTIC CHRONICLES

land to compete with Etruscan goods arriving from established trade routes from Italy through the Alpine passes. They were also trans-shipped overland between hill-forts to the Seine and across the English Channel to Cornwall. The hill-forts became the crossroads of inter-European trade.

In turn the Greeks traded ivory, from Africa, wine from the vineyards in the south; ceramics and dyes (used in fabrics), that the Celts exchanged for woven textiles, gold, silver and iron. The large Greek bronze cauldron found in the tomb at Hochdorf and the massive Greek bronze cauldron and drinking vessels found in the tomb at Mont Lassois testify to the trade at the time.

Excavated hill-fort sites frequently contained workshops of bronze-, silver- and gold-smiths suggesting that they were indeed secure trading posts established to accommodate the safe transshipment of goods from the time they appeared in around 580 BC to the time they were simultaneously abandoned in around 480 BC.

Although the Euro-Celts began to drift westwards into Britain and Ireland as early as 800 BC, it is likely that the period between 580 and 480 BC, coinciding with the boom in Euro trade, witnessed the heaviest migrations. Copies of French Celtic hill-forts began to appear in Britain from around 580 BC, the remains of one, the Ivinghoe Beacon, excavated in 2002 in Buckinghamshire, England, is believed to have been constructed in a similar way to the one at Mont Lassois.

The reason for the collapse of the Celtic hill-forts on the European mainland in around 480 BC is not clear and remains a matter for speculation. It could be that the Celts eventually gained a monopoly in tin, forcing the price upwards, which in turn accelerated the introduction and use of iron. Or perhaps the appearance of iron reduced the demand for bronze and hence tin, not only by the Celts but also by the Greeks. Whatever the reason, it marked the end of the Hallstatt D period sites at: Mont Lassois, Camp de Chassey, Mont Guerin and Montmorot in France; Breisach, Nagold and Hohenasperg in Germany; and Schiffenen and Chailion-sur Glane in Switzerland, and the beginning of the La Tène period of Celtic archaeology.

Glauberg

Of all of the Euro-Celtic archaeological sites, one located just south of Hochdorf dating to around the same period (c. 500 BC) deserves a men-

30

of the Stag, built in 1268, which survives today on the plaza of Strasbourg cathedral in France.

- Stag antlers can be used to represent thorn sprigs (figure 18a), emulating the crown of thorns worn by Christ at the crucifixion.

The snake was used by sun worshippers to describe the solar neutral sheet that twists and turns, snake-like, as it wraps itself around the Sun (appendix 3).

The stag was also one of the favoured eponyms of Lord Pacal, who often appears in Mayan transformers as the stag Xipe Totec (pron. *Sly-pee toe-tek*), the so-called Lord of the Stags and the Lord of Sacrifice in Mexico during the Mayan period. The Mural of Bonampak, a Mayan transformer, shows pictures of Xipe Totec being born in a stable and performing miracles, before going on to show him in another emanation as a man with a beard carrying a cross made of two pieces of wood.²² Finally, he appears bowing to an audience of two stags (plate 4) who applaud the end of the performance.

La Tène

In 1867, during a heat wave, the waters of Lake Neuchâtel in northwest Switzerland fell to their lowest level in living memory. It was then that an amateur archaeologist, Friedrich Schwab, noticed the ends of timbers sticking out from the bed of the lake. It was clear that the timber piles must have been driven in long ago and he eventually persuaded the authorities to allow him to excavate the area to determine what they might be. His digs in the lake sediment uncovered around forty iron swords and spears. In 1868 the lake was drained completely during civil engineering works intended to regulate inflows. More Celtic pieces were pulled from the mud including another 160 iron swords—slimmer than those found at Hallstatt—iron spearheads, shields, armour, tools and fibulae showing a style and decoration unfamiliar to archaeologists. Since then more than 3,000 pieces have been pulled from the lake, showing that La Tène was an important Celtic centre that flourished from c. 480 to 50 BC. The style and design of the pieces is livelier than the earlier Celtic period drawing upon the influence of classical Greece—with the appearance of swirling acanthus-leaf patterns,

35

THE CELTS

tion here. The Glauberg site, 32km (19.9 miles) north-east of Frankfurt was located from the air in 1987. Excavation of the 50-metre- (164-foot-) diameter tumulus (figure 16a) surrounded by a 70-metre- (230-foot-) diameter trench, began in 1996. A chamber located in the centre of the mound was found empty. Two burials excavated between 1998 and 2001 were found either side of the central chamber; Grave number 1 revealed a 2.25-metre by 1.07-metre by 1-metre-high (7 feet 5 inches by 3 feet 6 inches by 3 feet 3 inches) timber coffin containing cremated human remains together with burial goods typical of the period, including a bronze jar-like flagon, two groups of bronze buttons, a bronze brooch, a belt (with a bronze belt hook, fastening clasp, hole rings, small chain and ornamental rivets), an iron sword with a bronze and iron sheath, iron spearheads and iron arrow heads.

Grave 2 contained, the remains of human bones, three wooden spears with iron spearheads, a leather quiver with three iron-headed arrows, a long-bow, a wooden shield—with an iron frame—two gold earrings, a 21.5-cm- (8-inch-) long gold necklace, a belt (with a bronze belt hook, small chain, hole rings and ornamental rivets) two bronze rings, one golden bracelet, one gold finger-ring, an iron sword with a bronze scabbard, six small wooden rods with iron spouts, a bronze brooch, fragments of bronze rings, three small iron rivets, two bronze bird-headed brooches and a 52.2cm- (20-inch-) tall highly decorated bronze flagon.

These followed on from the 1996 discovery of a 1.86-metre- (6-foot 1-inch-) tall sandstone statue found in a wide trench west of the tomb (figure 16b). The excavators, unsure how to describe the highly unusual sculpture, labelled it 'a Celtic Prince'. But such an unusual looking prince would be hard to find; his unique appearance with his massive ears, forehead appendage and triple neck-drops identify him more closely as a representation of the Bat God, worshipped throughout Central America as the God of Death. This is not the first time the Bat God has been found in Hallstatt period excavations, the head of another so-called Celtic Prince, identical to this one, was found in Heidelberg—an interesting and unusual discovery, because it means that the sun worshipping Celts shared the same mythological beliefs of the Maya. That this is the case is further supported by the appearance of stag and snake carvings found prolifically on the swords, scabbards, flagons and jewellery in the two

31

corresponding with the appearance, design and style of four identifiable styles of weaponry—the appearance, design and length of swords, scabbards and spears; battle dress—shields and helmets; jewellery—brooches, necklets and torcs, bracelets, anklets and fibulae; pottery—vases, jugs, urns, cauldrons, buckets, jars, plates, drinking vessels and, most importantly in the colloquial sense, decorative Celtic art.

The early style of La Tène A was first observed in grave finds at the sites of Reinheim (figure 3) and Kleinaspergle in Germany and Basse Yutz in France. The Katzenbuckel group of tumuli, near Reinheim, just north of the German/French border on the River Blies, were completely flattened in antiquity and only rediscovered when quarrying activities in the area exposed the remains of a tomb, part of which was destroyed in the process. In 1954 excavations showed the burial to be that of another Celtic 'princess' from the early La Tène period, although the tomb was not as lavishly furnished as the earlier ones found at Hochdorf or Mont Lassois. Indeed, it is uncertain whether or not the tomb contained the remains of a male or female, the bones having long since perished in the acidic soil.

The treasures included a large twisted gold torc, two lignite bracelets, gold finger rings, bronze and gold fibulae, one resembling a rooster and inlaid with coral—used to tie clothing, almost none of which remained—a large quantity of amber and glass beads, a large bronze mirror with an anthropomorphic handle—found smashed despite being wrapped in fabric for protection—two bronze basins and a bronze flagon over 1 metre (3 feet 4 inches) in height. Two cylindrical gold bands were all that remained of an organic drinking horn. These last three items are together described as a 'banqueting set'. The absence of weapons and the quantity of jewellery are the only reasons to suggest that the occupant of the tomb was female.

In 1879 another tumulus was excavated, at Kleinaspergle, just 1,000 metres (3,280 feet) south of the Hohenasperg (figure 15) hill-fort in

contact. Only a few items were retrieved: a gold brooch and bracelet, three bronze plates, a large bronze bowl, a bronze Etruscan *stamnos* (a kind of cauldron), two gold drinking horn ends and four other drinking horn bands and discs. Two shallow drinking cups (*kylikes*) of a type made in Athens in around 450 BC had been embellished locally with gold foil without regard for the underlying Greek decoration. A large bronze flagon was found, typical of the period in style but not in decoration; the handle at the base end was attached to the body with the cast of a tiny human head and at the rim with an anthropomorphic face. Again, the absence of weapons persuaded archaeologists that the remains must be those of a female.

In 1927 at Basse Yutz, in France, a pair of bronze flagons of a similar style (plate 14) was found, during construction of a new road, together with two *stamnoi*. In 1929 the British Museum raised £5,000 to purchase the flagons which are now kept in its collection in London.

The 39.6-cm- (15.6-inch-) and 40.6-cm- (16-inch-) high flagons date from c. 400 BC and are particularly beautiful and of the highest quality craftsmanship. Each has a lid that can be removed and stored on a safety chain that is gripped in the mouth of a dog-like bronze head, on the handle, and the rim and the base are circumscribed with coral inlay. The lid contains a beautiful semi-spherical bronze stud patterned with tracery of bronze wire in-filled with coloured enamel (molten glass), the earliest known appearance of the *champlevé* technique.²³ The second of the La Tène phases is characterised with finds of a burial at Waldalgesheim on the junction of the Rivers Rhein and Nahe at Bingen near Mainz in Germany. In 1868 a farmer ploughing his land crashed into what was left of a tomb now described as that of another Celtic 'princess'. Only the metal fittings from what was once the yoke of a team of horses and parts of iron wagon wheels remain to suggest that the burial may indeed have been a wagon burial. No skeletal remains or clothing were found. The occupant wore a large ornately cast gold torc, three gold bracelets and two gold anklets. A large bronze flagon, found with a bronze jar, was incised with delicate compass-rendered

THE CELTIC CHRONICLES

graves at Glauberg.

The stag is a solar symbol known to have been worshipped by other sun worshipping civilizations; it sheds its antlers at yearly intervals—and the Earth orbits the Sun at yearly intervals. It is also closely associated with fertility—because the Sun's radiation regulates fertility on Earth. And because grass contains high amounts of cellulose, making it difficult to digest, it is a ruminator (it regurgitates food already swallowed, to chew again. [up to four times]), associating the stag with the notion of regurgitation [as in the case of regurgitation of a pearl in plate 3c] and reincarnation of the human soul on Earth.

And, stag-like associations do not end there:

God is light therefore God is the Sun and Jesus (as the Son of God) is therefore the Sun incarnate on Earth. This is to say that Jesus is the Sun and the stag is the Sun, so Jesus is the stag (figure 17 and 18).

Jesus is also known to have healed the sick with his bare hands, which is why pharmacies in France and Germany often carry the picture of a stag above the door. One example is the Pharmacy of the Stag, built in 1268, which survives today on the plaza of Strasbourg Cathedral in France.

Stag antlers can be used to represent (thorn sprigs (figure 18a) emanating the crown of thorns worn by Christ at the Crucifixion.

The snake was used by sun worshippers to describe the solar neutral sheet that twists and turns, snake-like, as it wraps itself around the Sun (Appendix 3).

The stag was also one of the favoured eponyms of Lord Pacal who often appears in Maya transformers as the stag Xipe Totec (pron. Shy-poe toe-tek), the so-called Lord of the Stags and the Lord of Sacrifice in Mexico during the Maya period. The Mural of Bonampak, a Maya transformer, shows pictures of Xipe Totec being born in a stable and performing miracles, before going on to show him in another emanation as a man with a beard carrying a cross made of two pieces of wood. Finally, he appears bowing to an audience of two stags (plate 4) who applaud the end of the performance. Plate 6 also shows Lord Pacal as a stag.

La Tène

In 1867, during a heat wave, the waters of Lake Neudatal in north-west

THE CELTS

The Glauberg Tumulus

Figure 16. (a) The tumulus at Glauberg was discovered in 1987 and has been under excavation since 1996. Two graves were found together with burial treasures and a magnificent sandstone statue that was given the name of 'the Celtic Prince' (b).

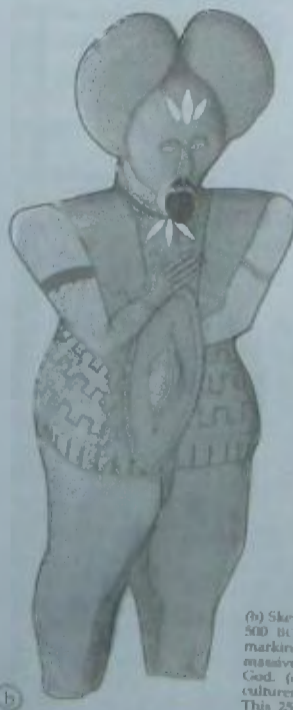
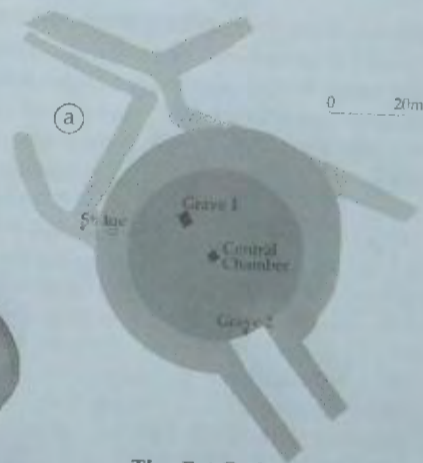

The Bat God



(b) Sketch of 6-foot (1.82 metre), 227kg (500 lb) statue c. 500 BC, excavated at Glauberg in 1996. Appendage markings on the forehead, triple neck pendants and massive ears suggest that the statue represents the Bat God. (c) The Bat God represented death by many cultures from the Olmecs, in Central America, onwards. This 25-piece jade figure, found in a tomb at Monte Albán, Mexico, dates from around AD700.

HAT SHOOK THE FREEMASONS

Ordinary discovery Express

An astute detective, Maurice Cottrell, and examines the life, times and tomb of a key from the pyramids of Mexico, which have kept the secrets of the world for more than 3,000 years.

As remarkable as they are sensational, the chamber was only part of the riddle that not have been Tutankhamun's father, the sun into his treasures, as a message to future generations.

ion in the Bible, the decoded treasures of those of Lord Pacal all tell the same story. It is known and thrives today, concealed and shared by the Church and the higher clergy. For the first time ever, Maurice Cottrell reveals the reasons for the secrecy, reasons which affect the future of us all.

Amazing books I have ever read in my life! bestselling author of The Outsider



loops, and anthropomorphic representations of stags, snakes, birds and unfamiliar creatures [perhaps mythical] all fused together with oriental and Hallstatt influence.

The La Tène period is divided into four phases: La Tène A (c. 480–400 BC); B (c. 400–250 BC); C (c. 250–120 BC) and D (c. 120–50 BC) corresponding with the appearance, design and style of four identifiable styles of weaponry—the appearance, design and length of swords, scabbards and spears; battle dress—shields and helmets; jewellery—brooches, necklets and torcs, bracelets, anklets and fibulae; pottery—vases, jugs, urns, cauldrons, buckets, jars, plates, drinking vessels and, most importantly in the colloquial sense, decorative Celtic art.

The early style of La Tène A was first observed in grave finds at the sites of Reinheim (figure 3) and Kleinaspergle in Germany and Basse Yutz in France. The Katzenbuckel group of tumuli, near Reinheim, just north of the German/French border on the River Blies, were completely flattened in antiquity and only rediscovered when quarrying activities in the area exposed the remains of a tomb, part of which was destroyed in the process. In 1954 excavations showed the burial to be that of another Celtic 'princess' from the early La Tène period, although the tomb was not as lavishly furnished as the earlier ones found at Hochdorf or Mont Lassois. Indeed, it is uncertain whether or not the tomb contained the remains of a male or female, the bones having long since perished in the acidic soil.

The treasures included a large twisted gold torc, two lignite bracelets, gold finger rings, bronze and gold fibulae, one resembling a rooster and inlaid with coral—used to tie clothing, almost none of which remained—a large quantity of amber and glass beads, a large bronze mirror with an anthropomorphic handle—found smashed despite being wrapped in fabric for protection—two bronze basins and a bronze flagon over 1 metre (3 feet 4 inches) in height. Two cylindrical gold bands were all that remained of an organic drinking horn. These last three items are together described as a 'banqueting set'. The absence of weapons and the quantity of jewellery are the only reasons to suggest that the occupant of the tomb was female.

In 1879 another tumulus was excavated, at Kleinaspergle, just 1,000 metres (3,280 feet) south of the Hohenasperg (figure 15) hill-fort in

Germany. This one stood at around 7.6 metres (25 feet) high and measured 60 metres (197 feet) in diameter. The central timber-clad chamber was empty and thought to have been robbed but a second chamber 2 metres (6 feet 6 inches) by 3 metres (9 feet 9 inches), to the west, was found intact. Only a few items were retrieved: a gold brooch and bracelets (a kind of cauldron), two gold drinking horn ends and four other drinking horn bands and discs. Two shallow drinking cups (*kylikes*) of a type made in Athens in around 450 BC had been embellished locally with gold foil without regard for the underlying Greek decoration. A large bronze flagon was found, typical of the period in style but not in decoration; the handle at the base end was attached to the body with the cast of a tiny human head and at the rim with an anthropomorphic face. Again, the absence of weapons persuaded archaeologists that the remains must be those of a female.

In 1927 at Basse Yutz, in France, a pair of bronze flagons of a similar style (plate 14) was found, during construction of a new road, together with two stamnoi. In 1929 the British Museum raised £5,000 to purchase the flagons which are now kept in its collection in London.

The 39.6-cm- (15.6-inch-) and 40.6-cm- (16-inch-) high flagons date from c. 400 BC and are particularly beautiful and of the highest quality craftsmanship. Each has a lid that can be removed and stored on a safety chain that is gripped in the mouth of a dog-like bronze head, on the handle, and the rim and the base are circumscribed with coral inlay. The lid contains a beautiful semi-spherical bronze stud patterned with tracery of bronze wire in-filled with coloured enamel (moiten glass), the earliest known appearance of the *champlevé* technique.²³ The second of the La Tène phases is characterised with finds of a burial at Waldalgesheim on the junction of the Rivers Rhein and Nahe at Bingen near Mainz in Germany. In 1868 a farmer ploughing his land crashed into what was left of a tomb now described as that of another Celtic 'princess'. Only the metal fittings from what was once the yoke of a team of horses and parts of iron wagon wheels remain to suggest that the burial may indeed have been a wagon burial. No skeletal remains or clothing were found. The occupant wore a large ornately cast gold torc, three gold bracelets and two gold anklets. A large bronze flagon, found with a bronze jar, was incised with delicate compass-rendered

graves at Glauberg.

The stag is a solar symbol known to have been worshipped by other sun worshipping civilizations; it sheds its antlers at yearly intervals—and the Earth orbits the Sun at yearly intervals. It is also closely associated with fertility—because the Sun's radiation regulates fertility on Earth. And because grass contains high amounts of cellulose, making it difficult to digest, it is a ruminator (it regurgitates food already swallowed, to chew again, [up to four times]), associating the stag with the notion of regurgitation [as in the case of regurgitation of a pearl in plate 3c] and reincarnation of the human soul on Earth.

And, stag-like associations do not end there:

God is light therefore God is the Sun and Jesus (as the Son of God) is therefore the Sun incarnate on Earth. This is to say that Jesus is the Sun and the stag is the Sun, so Jesus is the stag (figure 17 and 18).

Jesus is also known to have healed the sick with his bare hands, which is why pharmacies in France and Germany often carry the picture of a stag above the door. One example is the Pharmacy of the Stag, built in 1268, which survives today on the plaza of Strasbourg Cathedral in France.

Stag antlers can be used to represent thorn sprigs (figure 18a) emulating the crown of thorns worn by Christ at the Crucifixion. The snake was used by sun worshippers to describe the solar neutral about that twists and turns, snake-like, as it wraps itself around the Sun (Appendix 3).

The stag was also one of the favoured eponyms of Lord Pacal who often appears in Maya transformers as the stag Xipe Totec (pron. Shy'pee too-tek), the so-called Lord of the Stags and the Lord of Sacrifice in Mexico during the Maya period. The Mural of Bonampak, a Maya transformer, shows pictures²⁴ of Xipe Totec being born in a stable and performing miracles, before going on to show him in another emanation as a man with a beard carrying a cross made of two pieces of wood. Finally, he appears bowing to an audience of two stags (plate 4) who applaud the end of the performance. Plate 6 also shows Lord Pacal as a stag.

In 1867, during a heat wave, the waters of Lake Neuchâtel in north-west

The Glauberg Tumulus

Figure 16. (a) The tumulus at Glauberg was discovered in 1987 and has been under excavation since 1996. Two graves were found together with burial treasures and a magnificent sandstone statue that was given the name of the Celtic Prince (b).

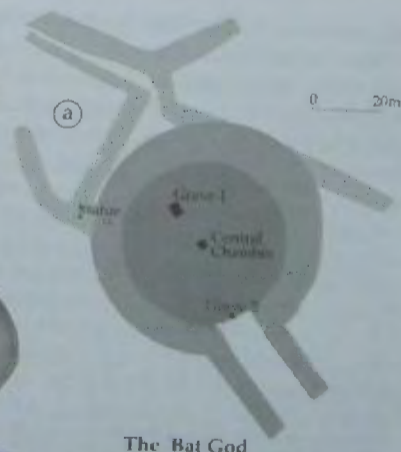

(b) Sketch of statue (1.82 metres, 227kg, 500 BC) statue c. 500 BC, excavated at Glauberg in 1996. Appendage markings on the forehead, triple neck pendants and massive ears suggest that the statue represents the Bat God. (c) The Bat God represented death by many cultures from the Olmecs, to Central America, onwards. The Zapotec jade figure, found in a tomb at Monte Alban, Mexico, dates from around 400 BC.

floral geometric carving in the form of winding tendrils and leaves, representing the first appearance of the style which more than anything typifies the art style of the Celts as we know it today. The same style is found on a gold helmet from the same period at Amfreville-sous-les-Monts.

Metalsmiths of the day covered surfaces of pots, swords, scabbards, helmets and jewellery with patterns interspersed with animal and human heads. It is still not known how the gold filigree work, with its arabesques, arches and curves that twist and turn, encompassing human faces with goggle-eyes, full-blown cheeks, bulbous noses and twisting mouths, could have been carried out on such a seemingly microscopic scale so successfully and all, ostensibly, without magnification to aid the production process.

The La Tène A period is thus characterised by the presence of tumulus tombs—some of which contained bodily remains and others cremated remains; Hallstatt-style swords—where the longer and slimmer blade is counterbalanced by either a trident head or an antenna-like handle termination; and developments in the Hallstatt style of fibulae—but with turned-up ends.

The La Tène B period is characterised by tumulus burials and surface graves, swords, some with a curved scabbard mouth and miniature circular openwork (for example, a Celtic cross with open [see-through] segments) termination at the sharp end. The phase began with the appearance of decorative coral incrustation and enamelled glasswork beading set in mounts, as with the Basse Yutz flagons.

During the third period of La Tène the beautiful rococo decorative artwork developed further and even more delicately. Coral incrustation became more prolific. Enamel glasswork became more commonplace and swords became even longer, without the openwork on the scabbard.

During the final La Tène phase the tips of swords became blunt and rounded, scabbards straight-mouthed, fibulae cast and enamelled beads more sophisticated and ambitious with the introduction of different colours to the glass enamel inlay. But the closing of the third phase of the La Tène period had one last thing to reveal, probably the most famous Celtic treasure of all: a curious silver bowl.

The Gundestrup Cauldron

In 1891 a 35-cm- (14 inch-) high, 71-cm- (28 inch-) diameter highly decorated blackened and battered silver cauldron (figure 19a) weighing 9.1 kg (20 lbs) was discovered in a peat bog at Raevemose, Gundestrup, North Jutland, Denmark. It shows, say archaeologists, scenes of Celtic life on each of thirteen tiny embossed gold plated silver panels, or platelets, clipped to the main silver bowl. One of five platelets, hanging from the inside wall, features the Celtic so-called god of hunting Cernunnos (figure 20) who sits semi-cross-legged surrounded by nine creatures. In his right hand he holds high a torc and wears another around his neck.

Those aware of the true nature and purpose of Celtic mythology will see more in this scene. On his forehead Cernunnos wears the horns of a stag, associating the wearer with the Sun, light, God, and healing. As we noted earlier, the stag is also associated with Jesus. The ellipse-shaped torc in the right hand of Cernunnos depicts the path of the Sun, proclaiming reverence for the Sun. The ends of the torc terminate with two spheres, representing the various manifestations of Venus as the morning star and the evening star. His body, within a second torc [around his neck], thus becomes the body between the morning star and the evening star—the Sun, light, or God. Cernunnos is hence explicitly portrayed as Jesus on the Gundestrup Cauldron, as he is in the Bible, which surely means that the Gundestrup Cauldron tells, at least in part, the story of Jesus. But in c. 100 BC, the time the cauldron was manufactured, Jesus had not yet appeared on Earth, which can only mean that the appearance of the Celtic God Cernunnos refers, like the Old Testament of the Bible, to the future coming of Christ (if the dating of the cauldron is correct).

This interpretation is also supported by the appearance of another character nearby Cernunnos, a small child riding on the back of a dolphin. The Greek and Roman sun god was Apollo, the twin child (together with his sister Artemis) of the creator god Zeus. Legend says that Apollo was carried on the back of a dolphin from his birthplace, the island of Delos, to Mount Parnassus, where he seized control of the oracle from the Earth Mother. His chief oracular shrine was in Delphi which he won by killing the oracle's serpent protector, Python. We

The Stag, The Sun and the Cross



Figure 12. A label from a bottle of herbal liquor made in Germany and sold in Ireland today, showing that the stag's antlers associated with the Sun, the cross of Christ and the medicinal/healing qualities of herbs.



The Stag, The Antlers and the Crown of Thorns



Figure 13. The 'Crown of Thorns'—the stag's antlers associated with the Sun, the cross of Christ and the medicinal/healing qualities of herbs.



Switzerland fell to their lowest level in living memory. It was then that an amateur archaeologist Freiderich Schwab noticed the ends of timbers sticking out from the bed of the lake. It was clear that the timber piles must have been driven-in long ago and he eventually persuaded the authorities to allow him to excavate the area to determine what they might be. His digs in the lake sediment uncovered around 40 iron swords and spears. In 1868 the lake was drained completely during civil engineering works intended to regulate inflows. More Celtic pieces were pulled from the mud including another 160 iron swords—slimmer than those found at Hallstatt—iron spearheads, shields, armour, tools and fibulae showing a style and decoration unfamiliar to archaeologists. Since then more than 3,000 pieces have been pulled from the lake showing that La Tène was an important Celtic centre that flourished from c. 480-50 BC. The style and design of the pieces is livelier than the earlier Celtic period drawing upon the influence of classical Greece—with the appearance of swirling acanthus-leaf patterns, loops, and anthropomorphic representations of stags, snakes, birds and unfamiliar creatures [perhaps mythical] all fused together with oriental and Hallstatt influence.

The La Tène period is divided into four phases; La Tène A (c. 480-400 BC); B (c. 400-250 BC); C (c. 250-120 BC) and D (c. 120-50 BC) corresponding with the appearance, design and style of four identifiable styles of weaponry—the appearance, design and length of swords, scabbards and spears; battle-dress—shields and helmets; jewellery—brooches, necklets and torcs, bracelets, anklets and fibulae; pottery—vases, jugs, urns, cauldrons, buckets, jars, plates, drinking vessels and, most importantly in the colloquial sense, decorative Celtic art.

The early style of La Tène A, was first observed in grave finds at the sites of Reinheim (figure 3) and Kleinaspergle in Germany and Basse Yutz in France. The Katzenbuckel group of Tumuli, near Rheinheim, just north of the German/French border on the river Blies, were completely flattened in antiquity and only rediscovered when quarrying activities in the area exposed the remains of a tomb, part of which was destroyed in the process. In 1954 excavations showed the burial to be that of another Celtic 'princess' from the early La Tène period, although the tomb was not as lavishly furnished as the earlier ones found at Hochdorf or Mont Lassois. Indeed, it is uncertain whether or not the tomb contained the remains of a male or female, the bones having long since perished in

SONS
all the
footsteps
amb of
exico,
of the

floral geometric carving in the form of winding tendrils and leaves, representing the first appearance of the style which more than anything typifies the art style of the Celts as we know it today. The same style is found on a gold helmet from the same period at Amfreville-sous-les-Monts.

Metalsmiths of the day covered surfaces of pots, swords, scabbards, helmets and jewellery with patterns interspersed with animal and human heads. It is still not known how the gold filigree work, with its arabesques, arches and curves that twist and turn, encompassing human faces with goggle-eyes, full-blown cheeks, bulbous noses and twisting mouths, could have been carried out on such a seemingly microscopic scale so successfully and all, ostensibly, without magnification to aid the production process.

The La Tène A period is thus characterised by the presence of tumulus tombs—some of which contained bodily remains and others cremated remains; Hallstatt-style swords—where the longer and slimmer blade is counterbalanced by either a trident head or an antenna-like handle termination; and developments in the Hallstatt style of fibulae—but with turned-up ends.

The La Tène B period is characterised by tumulus burials and surface graves, swords, some with a curved scabbard mouth and miniature circular openwork (for example, a Celtic cross with open [see-through] segments) termination at the sharp end. The phase began with the appearance of decorative coral incrustation and enamelled glasswork beading set in mounts, as with the Basse Yutz flagons.

During the third period of La Tène the beautiful rococo decorative artwork developed further and even more delicately. Coral incrustation became more prolific. Enamel glasswork became more commonplace and swords became even longer, without the openwork on the scabbard.

During the final La Tène phase the tips of swords became blunt and rounded, scabbards straight-mouthed, fibulae cast and enamelled beads more sophisticated and ambitious with the introduction of different colours to the glass enamel inlay. But the closing of the third phase of the La Tène period had one last thing to reveal, probably the most famous Celtic treasure of all: a curious silver bowl.

The Gundestrup Cauldron

In 1891 a 35-cm- (14 inch-) high, 71-cm- (28 inch-) diameter highly decorated blackened and battered silver cauldron (figure 19a) weighing 9.1 kg (20 lbs) was discovered in a peat bog at Raevemose, Gundestrup, North Jutland, Denmark. It shows, say archaeologists, scenes of Celtic life on each of thirteen tiny embossed gold plated silver panels, or platelets, clipped to the main silver bowl. One of five platelets, hanging from the inside wall, features the Celtic so-called god of hunting Cernunnos (figure 20) who sits semi-cross-legged surrounded by nine creatures. In his right hand he holds high a torc and wears another around his neck.

Those aware of the true nature and purpose of Celtic mythology will see more in this scene. On his forehead Cernunnos wears the horns of a stag, associating the wearer with the Sun, light, God, and healing. As we noted earlier, the stag is also associated with Jesus. The ellipse-shaped torc in the right hand of Cernunnos depicts the path of the Sun, proclaiming reverence for the Sun. The ends of the torc terminate with two spheres, representing the various manifestations of Venus as the morning star and the evening star. His body, within a second torc [around his neck], thus becomes the body between the morning star and the evening star—the Sun, light, or God. Cernunnos is hence explicitly portrayed as Jesus on the Gundestrup Cauldron, as he is in the Bible, which surely means that the Gundestrup Cauldron tells, at least in part, the story of Jesus. But in c. 100 BC, the time the cauldron was manufactured, Jesus had not yet appeared on Earth, which can only mean that the appearance of the Celtic God Cernunnos refers, like the Old Testament of the Bible, to the future coming of Christ (if the dating of the cauldron is correct).

This interpretation is also supported by the appearance of another character nearby Cernunnos, a small child riding on the back of a dolphin. The Greek and Roman sun god was Apollo, the twin child (together with his sister Artemis) of the creator god Zeus. Legend says that Apollo was carried on the back of a dolphin from his birthplace, the island of Delos, to Mount Parnassus, where he seized control of the oracle from the Earth Mother. His chief oracular shrine was in Delphi which he won by killing the oracle's serpent protector, Python. We

THE CELTIC CHRONICLES

The Stag, The Sun and the Cross



Figure 17. A label from a bottle of herbal liquor made in Germany and sold in Ireland today, showing that the stag is still associated with the Sun, the cross of Christ and the medicinal healing qualities of herbs.

The Stag, The Antlers and the Crown of Thorns

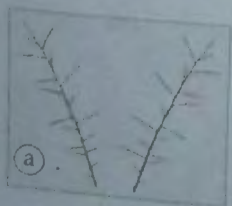

Figure 18. (a) Thorny branches. (b) Roman soldiers preparing Jesus with a crown of thorns to mock his crucifixion.



Switzerland fell to their lowest level in living memory. It was then that an amateur archaeologist Freiderich Schwab noticed the ends of timbers sticking out from the bed of the lake. It was clear that the timber piles must have been driven in long ago and he eventually persuaded the authorities to allow him to excavate the area to determine what they might be. His digs in the lake sediment uncovered around 40 iron swords and spears. In 1868 the lake was drained completely during civil engineering works intended to regulate inflows. More Celtic pieces were pulled from the mud including another 160 iron swords—slimmer than those found at Hallstatt—iron spearheads, shields, armour, tools and fibulae showing a style and decoration unfamiliar to archaeologists. Since then more than 3,000 pieces have been pulled from the lake showing that La Tène was an important Celtic centre that flourished from c. 480–50 BC. The style and design of the pieces is livelier than the earlier Celtic period drawing upon the influence of classical Greece—with the appearance of swirling acanthus-leaf patterns, loops, and anthropomorphic representations of stags, snakes, birds and unfamiliar creatures [perhaps mythical] all fused together with oriental and Hallstatt influence.

The La Tène period is divided into four phases; La Tène A (c. 480–400 BC); B (c. 400–250 BC); C (c. 250–120 BC) and D (c. 120–50 BC) corresponding with the appearance, design and style of four identifiable styles of weaponry—the appearance, design and length of swords, scabbards and spears; battle-dress—shields and helmets; jewellery—brooches, necklets and torcs, bracelets, anklets and fibulae; pottery—vases, jugs, urns, cauldrons, buckets, jars, plates, drinking vessels and, most importantly in the colloquial sense, decorative Celtic art.

The early style of La Tène A, was first observed in grave finds at the sites of Reinheim (figure 3) and Kleinaspergle in Germany and Basse Yutz in France. The Katzenbuckel group of Tumuli, near Rheinheim, just north of the German/French border on the river Blies, were completely flattened in antiquity and only rediscovered when quarrying activities in the area exposed the remains of a tomb, part of which was destroyed in the process. In 1954 excavations showed the burial to be that of another Celtic 'princess' from the early La Tène period, although the tomb was not as lavishly furnished as the earlier ones found at Hochdorf or Mont Lassols. Indeed, it is uncertain whether or not the tomb contained the remains of a male or female, the bones having long since perished in

The Gundestrup Cauldron



Figure 19. (a) The Gundestrup Cauldron, c. 100 BC, found at the Raevemose peat bog in Jutland, Denmark, in 1891. (b) Slaughtered bull (inside base).

40

THE CELTIC CHRONICLES

the acidic soil.

The treasures included a large twisted gold torc, two lignite bracelets, gold finger-rings, bronze and gold fibulae, one resembling a rooster and inlaid with coral—used to tie clothing, almost none of which remained—a large quantity of amber and glass beads, a large bronze mirror with an anthropomorphic handle—found smashed despite being wrapped in fabric for protection, two bronze basins and a bronze flagon—over 1-metre (3 feet 4 inches) in height. Two cylindrical gold bands were all that remained of an organic drinking horn. These last three items are together described as a 'banqueting set'. The absence of weapons and the quantity of jewellery are the only reasons to suggest that the occupant of the tomb was female.

In 1879 another tumulus was excavated, at Kleinaspergle, just 1000 metres (3,280 feet) south of the Hohenasperg (figure 15) hill-fort in Germany. This one stood at around 7.6 metres- (25 feet-) high and measured 60 metres (197 feet) in diameter. The central timber-clad chamber was empty and thought to have been robbed but a second chamber 2 metres (6 feet 6 inches) by 3 metres (9 feet 9 inches), to the west, was found intact. Only a few items were retrieved; a gold brooch and bracelet, three bronze plates, a large bronze bowl, a bronze Etruscan stamnos (a kind of cauldron), two gold drinking horn ends and four other drinking horn bands and discs. Two shallow drinking cups (kylikes) of a type made in Athens in around 450 BC had been embellished locally with gold foil without regard for the underlying Greek decoration. A large bronze flagon was found, typical of the period in style but not in decoration; the handle at the base end was attached to the body with the cast of a tiny human head and at the rim with an anthropomorphic face. Again, the absence of weapons persuaded archaeologists that the remains must be those of a female.

In 1927 at Basse Yutz, in France, a pair of bronze flagons of a similar style (plate 14) was found, during construction of a new road, together with two stamnoi. In 1929 the British Museum raised £5,000 to purchase the flagons which are now kept in its collection in London.

The 39.6cm (15.6-inch-) and 40.6cm- (16-inch-) high flagons date from c. 400 BC and are particularly beautiful and of the highest quality craftsmanship. Each has a lid that can be removed and stored on a safety chain

Cernunnos



Figure 20. Detail showing Cernunnos, the Celtic God. In his right hand he holds the ellipse-shaped Celtic torc that depicts the path of (and hence) the Sun. The ends of the torc terminate with spheres, representing the various names/stations of the two-star (planets) Venus as the morning star and the evening star. His body, within a second torc (around his neck), thus becomes the body between the morning star and the evening star—the Sun, light and God. Cernunnos is here associated with the Sun. On his head he wears the horns of the stag that sheds its antlers annually associating the stag with a twisted horn around his forehead—representing the crown of thorns worn by Jesus at the Crucifixion. The Gundestrup Cauldron, like the (Old Testament of the Bible, tells of the coming of Christ [for the Celts]).

THE CELTS

that is gripped in the mouth of a dog-like bronze head, on the handle, and the rim and the base are circumscribed with coral inlay. The lid contains a beautiful semispherical bronze stud patterned with tracery of bronze wire in-filled with coloured enamel (molten glass), the earliest known appearance of the *champlevé*²³ technique. The second of the La Tène phases is characterised with finds of a burial at Waldalgesheim on the junction of the Rivers Rhein and Nahe at Bingen near Mainz in Germany. In 1868 a farmer ploughing his land crashed into what was left of a tomb now described as that of another Celtic 'princess'. Only the metal fittings from what was once the yoke of a team of horses and parts of iron wagon wheels remain to suggest that the burial may indeed have been a wagon burial. No skeletal remains or clothing were found. The occupant wore a large ornately cast gold torc, three gold bracelets and two gold anklets. A large bronze flagon, found with a bronze jar, was incised with delicate compass-rendered floral geometric carving in the form of winding tendrils and leaves, representing the first appearance of the style which more than anything typifies the art style of the Celts as we know it today. The same style is found on a gold helmet from the same period at Amfreville-sous-les-Monts.

Metalsmiths of the day covered surfaces of pots, swords, scabbards, helmets and jewellery with patterns interspersed with animal and human heads. It is still not known how the gold filigree-work, with its arabesques, arches and curves, that twist and turn, encompassing human faces with goggle-eyes, full blown cheeks, bulbous noses and twisting mouths, could have been carried out on such a seemingly microscopic scale so successfully and all, ostensibly, without magnification to aid the production process.

The La Tène A period is thus characterised by the presence of tumulus tombs—some of which contained bodily remains and others cremated remains; Hallstatt-style swords—where the longer and slimmer blade is counter balanced by either a trident-head or an antenna-like handle termination; and developments in the Hallstatt style of fibulae—but with turned-up ends.

The La Tène B period is characterised by tumulus burials and surface graves, swords, some with a curved scabbard-mouth and miniature circular openwork (for example a Celtic cross with open [see-through] seg-

The Gundestrup Cauldron



Figure 19. (a) The Gundestrup Cauldron, c. 100 BC, found at the Raevemose peat bog in Jutland, Denmark, in 1891. (b) Slaughtered bull (inside base).

THE CELTIC CHRONICLES

ments) termination at the sharp end. The phase began with the appearance of decorative coral incrustation and enamelled glasswork beading set in mounts, as with the Basse Yutz flagons.

During the third period of La Tène the beautiful rococo decorative artwork developed further and even more delicately. Coral incrustation became more prolific. Enamel glasswork became more commonplace and swords became even longer, without the openwork on the scabbard.

During the final La Tène phase the tips of swords became blunt and rounded, scabbards straight-mouthed, fibulae cast and enamelled beads more sophisticated and ambitious with the introduction of different colours to the glass enamel inlay. But the closing of the third phase of the La Tène period had one last thing to reveal, probably the most famous Celtic treasure of all; a curious silver bowl.

The Gundestrup Cauldron

In 1891 a 35cm- (14 inch-) high, 71cm- (28 inch-) diameter highly decorated blackened and battered silver cauldron (figure 19a) weighing 9.1kg (20lbs), was discovered in a peat bog at Ravemose, Gundestrup, north Jutland, Denmark. It shows, say archaeologists, scenes of Celtic life on each of 13 tiny embossed gold plated silver panels, or platelets, clipped to the main silver bowl. One of five platelets, hanging from the inside wall, features the Celtic so-called God of hunting Cernunnos (figure 20) who sits semi cross-legged surrounded by nine creatures. In his right hand he holds high a torc and wears another around his neck.

Those aware of the true nature and purpose of Celtic mythology will see more in this scene. On his forehead Cernunnos wears the horns of a stag, associating the wearer with the Sun, light, God, and healing. As we noted earlier, the stag is also associated with Jesus. The ellipse-shaped torc in the right hand of Cernunnos depicts the path of the Sun, proclaiming reverence of the Sun. The ends of the torc terminate with two spheres, representing the various manifestations of Venus as the morning star and the evening star. His body, within a second torc [around his neck] thus becomes the body between the morning star and the evening star—the Sun, light, or God. Cernunnos is hence explicitly portrayed as Jesus on the Gundestrup Cauldron, as he is in the Bible. Which surely means that the Gundestrup Cauldron tells, at least in part, the story of

Cernunnos



Figure 20. Detail showing Cernunnos, the Celtic God. In his right hand he holds the ellipse-shaped Celtic torc that depicts the path of (and hence) the Sun. The ends of the torc terminate with spheres, representing the various manifestations of the twin-star (planet) Venus as the morning star and the evening star. His body, within a second torc [around his neck], thus becomes the body between the morning star and the evening star—the Sun, light, or God. Cernunnos is hence associated with the Sun. On his head he wears the horns of a stag that sheds its antlers annually associating the stag with the Sun, light and God. The stag is the eponym of Jesus. The antlers also resemble sprigs of thorns and close examination shows Cernunnos wearing a twisted band around his forehead—representing the crown of thorns worn by Jesus at the Crucifixion. The Gundestrup Cauldron, like the Old Testament of the Bible, tells of the coming of Christ [for the Celts].

THE CELTS

The Gundestrup Cauldron



Figure 19. (a) The Gundestrup Cauldron, c. 100 BC, found at the Raevemose peat bog in Jutland, Denmark in 1891. (b) Slaughtered bull (inside base).

The Gundestrup Cauldron



Figure 19. (a) The Gundestrup Cauldron, c. 100 BC, found at the Raevemose peat bog in Jutland, Denmark, in 1891. (b) Slaughtered bull (inside base).

THE CELTIC CHRONICLES

ments) termination at the sharp end. The phase began with the appearance of decorative coral incrustation and enamelled glasswork beading set in mounts, as with the Basse Yutz flagons.

During the third period of La Tène the beautiful rococo decorative artwork developed further and even more delicately. Coral incrustation became more prolific. Enamel glasswork became more commonplace and swords became even longer, without the openwork on the scabbard.

During the final La Tène phase the tips of swords became blunt and rounded, scabbards straight-mouthed, fibulae cast and enamelled beads more sophisticated and ambitious with the introduction of different colours to the glass enamel inlay. But the closing of the third phase of the La Tène period had one last thing to reveal, probably the most famous Celtic treasure of all; a curious silver bowl.

The Gundestrup Cauldron

In 1891 a 35cm- (14 inch-) high, 71cm- (28 inch-) diameter highly decorated blackened and battered silver cauldron (figure 19a) weighing 9.1kg (20lbs), was discovered in a peat bog at Ravemose, Gundestrup, north Jutland, Denmark. It shows, say archaeologists, scenes of Celtic life on each of 13 tiny embossed gold plated silver panels, or platelets, clipped to the main silver bowl. One of five platelets, hanging from the inside wall, features the Celtic so-called God of hunting Cernunnos (figure 20) who sits semi cross-legged surrounded by nine creatures. In his right hand he holds high a torc and wears another around his neck.

Those aware of the true nature and purpose of Celtic mythology will see more in this scene. On his forehead Cernunnos wears the horns of a stag, associating the wearer with the Sun, light, God, and healing. As we noted earlier, the stag is also associated with Jesus. The ellipse-shaped torc in the right hand of Cernunnos depicts the path of the Sun, proclaiming reverence of the Sun. The ends of the torc terminate with two spheres, representing the various manifestations of Venus as the morning star and the evening star. His body, within a second torc (around his neck) thus becomes the body between the morning star and the evening star—the Sun, light, or God. Cernunnos is hence explicitly portrayed as Jesus on the Gundestrup Cauldron, as he is in the Bible. Which surely means that the Gundestrup Cauldron tells, at least in part, the story of

Cernunnos



Figure 20. Detail showing Cernunnos, the Celtic God. In his right hand he holds the ellipse-shaped Celtic torc that depicts the path of (and hence) the Sun. The ends of the torc terminate with spheres, representing the various manifestations of the twin-star (planet) Venus as the morning star and the evening star. His body, within a second torc (around his neck), thus becomes the body between the morning star and the evening star—the Sun, light, or God. Cernunnos is hence associated with the Sun. On his head he wears the horns of the stag that sheds its antlers annually assuring the stag with the Sun, light, and God. The stag is the eponym of Jesus. The antlers also resemble sprigs of thorns and; thus, examination shows Cernunnos wearing a twisted band around his forehead—representing the crown of thorns worn by Jesus at the Crucifixion. The Gundestrup Cauldron, like the Old Testament of the Bible, tells of the coming of Christ [for the Celts].

THE CELTS

The Gundestrup Cauldron



Figure 19. (a) The Gundestrup Cauldron, c. 100 BC, found at the Raevemose peat bog in Jutland, Denmark in 1891. (b) Slaughtered bull (inside base).



Figure 19. (a) The Gundestrup Cauldron, c. 100 BC, found at the Raevemose peat bog in Jutland, Denmark, in 1891. (b) Slaughtered bull (inside base).



Figure 20. Detail, showing Cernunnos, the Celtic God. In his right hand he holds the ellipse-shaped Celtic torc that depicts the path of (and hence) the Sun. The ends of the torc terminate with spheres, representing the various manifestations of the twin-star (planet) Venus as the morning star and the evening star. His body, within a second torc (around his neck), thus becomes the body between the morning star and the evening star—the Sun, light, God. Cernunnos is hence associated with the Sun. On his head he wears the horns of the stag that sheds its antlers annually, associating the stag with the Sun, light and God. The stag is the eponym of Jesus. The antlers also resemble sprigs of thorns and close examination shows Cernunnos wearing a twisted band around his forehead—representing the crown of thorns worn by Jesus at the Crucifixion. The Gundestrup Cauldron, like the Old Testament of the Bible, tells of the coming of Christ (for the Celts).



Figure 20. Detail showing Cernunnos, the Celtic God. In his right hand he holds the ellipse-shaped Celtic torc that depicts the path of (and hence) the Sun. The ends of the torc terminate with spheres, representing the various manifestations of the twin-star (planet) Venus as the morning star and the evening star. His body, within a second torc (around his neck), thus becomes the body between the morning star and the evening star—the Sun, light, God. Cernunnos is hence associated with the Sun. On his head he wears the horns of the stag that sheds its antlers annually associating the stag with the Sun, light and God. The stag is the eponym of Jesus. The antlers also resemble sprigs of thorns and close examination shows Cernunnos wearing a twisted band around his forehead—representing the crown of thorns worn by Jesus at the Crucifixion. The Gundestrup Cauldron, like the Old Testament of the Bible, tells of the coming of Christ (for the Celts).

Jesus. But in c. 100 BC, the time the cauldron was manufactured, Jesus had not yet appeared on Earth, which can only mean that the appearance of the Celtic God Cernunnos refers, like the Old Testament of the Bible, to the future coming of Christ (if the dating of the cauldron be correct).

This interpretation is also supported by the appearance of another character nearby Cernunnos, a small child riding on the back of a dolphin. The Greek and Roman Sun God was Apollo, the twin child (together with his sister Artemis) of the creator god Zeus. Legend says that Apollo was carried on the back of a dolphin from his birthplace, the island of Delos, to Mount Parnassus, where he seized control of the oracle from the Earth Mother. His chief oracular shrine was in Delphi which he won by killing the oracle's serpent protector, Python. We noted earlier (footnote 15) that Chi Zeus was the name given to Christ in the Bible. On the cauldron Cernunnos is likewise associated with the son of Zeus and he holds what appears to be a serpent, safely behind the jaw (as though in conquest) in his left hand. It is worth mentioning here that Apollo was also known as the archer who, like Jesus, aimed at the heart.

Other scenes on the inside platelets show what can only be described as scenes of Hell, with individuals, hanging upside-down, being submerged into vats of boiling liquid, and soldiers carrying spears, marching alongside cavalry, wearing boot spurs—dating the object to no earlier than around c. 100 BC, when spurs were first identified as part of Celtic armoury.

The centre circle on the base inside the cauldron features a remarkable scene of, what has been described as, 'a dying bull pursued by a hunter and two dogs' (figure 19b). Between 1400 BC and AD 400 Persians, Indians and Greeks worshipped the sky god Mithras, who was also popular with the Romans in the first century BC. Legend says that the Sun God sent his messenger, the raven, to command Mithras to sacrifice a great bull. Mithras reluctantly obeyed and when the bull died a great miracle occurred—the world began. The cloak of Mithras was turned into a celestial globe on which the planets and stars were shining²⁴. Sacrifice of the Bull was the central theme of Mithraism. Another account says that seeing the afflictions suffered to mankind, Mithras came down to Earth, where his birth was witnessed on December 25th by shepherds²⁵.

noted earlier (endnote 15) that Chi Zeus was the name given to Christ in the Bible. On the cauldron Cernunnos is likewise associated with the son of Zeus and he holds what appears to be a serpent, safely behind the jaw (as though in conquest) in his left hand. It is worth mentioning here that Apollo was also known as the archer, who, like Jesus, aimed at the heart.

Other scenes on the inside platelets show what can only be described as scenes of hell, with individuals hanging upside down, being submerged into vats of boiling liquid, and soldiers carrying spears, marching alongside cavalry, wearing boot spurs—dating the object to no earlier than c. 100 BC, when spurs were first identified as part of Celtic armoury.

The centre circle on the base inside the cauldron features a remarkable scene of what has been described as 'a dying bull pursued by a hunter and two dogs' (figure 19b). Between 1400 BC and AD 400 Persians, Indians and Greeks worshipped the sky god Mithras, who was also popular with the Romans in the first century BC. Legend says that the Sun god sent his messenger the raven to command Mithras to sacrifice a great bull. Mithras reluctantly obeyed and when the bull died a great miracle occurred—the world began. The cloak of Mithras was turned into a celestial globe on which the planets and stars were shining.²⁴ Sacrifice of the bull was the central theme of Mithraism. Another account says that seeing the afflictions suffered by mankind, Mithras came down to Earth, where his birth was witnessed on December 25th by shepherds.²⁵

In Ireland the Celtic bull-sacrifice (tarb-feis) was an integral feature of the inauguration of a new king, a ceremony of deep religious significance in Celtic Irish society.

Seven platelets clipped to the outside wall of the cauldron feature a man with raised arms, contemporaneously described as one of the barbarian Teutons that roamed Germany during those times.

The so-called Teutons with raised arms (figure 21a) have more to say: figure 21b shows the man with raised arms that covers the face of Lord Pacal from one of the decoded pictures from the Amazing Lid of Palenque (plate 5b). Figure 21c shows another representation of the same character with raised arms from the tomb of Viracocha in Peru. Both appearances of the small man are characterised and distinguished

The Mystery of the Man with Raised Arms



(a)



(b)



(c)

Figure 21. (a) Scene of a man with raised arms, from the Gundestrup Cauldron, shown with two stags, like Lord Pacal in the Mural of Bonampak (plates 4 and 6). (b) Decoded picture of a man, also with raised arms, from Lord Pacal's Amazing Lid of Palenque (plate 5b). (c) Figure of a man with raised arms from the tomb of Viracocha Pachacamac, Peru.

Cernunnos



Figure 20. Detail, showing Cernunnos, the Celtic God. In his right hand he holds the ellipse-shaped Celtic torc that depicts the path of (and hence) the Sun, star. His body, within a second torc, (around his neck) thus becomes the body between the morning star and the evening star—the Sun, light, God, light and God. The stag is hence associated with the Sun. On his head he wears the horns of the stag that sheds its antlers annually, associating the stag with the Sun, around his forehead—representing the crown of thorns worn by Jesus, at the Crucifixion. The Gundestrup Cauldron, like the Old Testament of the Bible, tells of the coming of Christ (for the Celts)

Jesus. But in c. 100 BC, the time the cauldron was manufactured, Jesus had not yet appeared on Earth, which can only mean that the appearance of the Celtic God Cernunnos refers, like the Old Testament of the Bible, to the future coming of Christ (if the dating of the cauldron be correct).

This interpretation is also supported by the appearance of another character nearby Cernunnos, a small child riding on the back of a dolphin. The Greek and Roman Sun God was Apollo, the twin child (together with his sister Artemis) of the creator god Zeus. Legend says that Apollo was carried on the back of a dolphin from his birthplace, the island of Delos, to Mount Parnassus, where he seized control of the oracle from the Earth Mother. His chief oracular shrine was in Delphi which he won by killing the oracle's serpent protector, Python. We noted earlier (footnote 15) that Chi Zeus was the name given to Christ in the Bible. On the cauldron Cernunnos is likewise associated with the son of Zeus and he holds what appears to be a serpent, safely behind the jaw (as though in conquest) in his left hand. It is worth mentioning here that Apollo was also known as the archer who, like Jesus, aimed at the heart.

Other scenes on the inside platelets show what can only be described as scenes of Hell, with individuals, hanging upside-down, being submerged into vats of boiling liquid, and soldiers carrying spears, marching alongside cavalry, wearing boot spurs—dating the object to no earlier than around c. 100 BC, when spurs were first identified as part of Celtic armoury.

The centre circle on the base inside the cauldron features a remarkable scene of, what has been described as, 'a dying bull pursued by a hunter and two dogs' (figure 19b). Between 1400 BC and AD 400 Persians, Indians and Greeks worshipped the sky god Mithras, who was also popular with the Romans in the first century BC. Legend says that the Sun God sent his messenger, the raven, to command Mithras to sacrifice a great bull. Mithras reluctantly obeyed and when the bull died a great miracle occurred—the world began. The cloak of Mithras was turned into a celestial globe on which the planets and stars were shining²⁴. Sacrifice of the Bull was the central theme of Mithraism. Another account says that seeing the afflictions suffered to mankind, Mithras came down to Earth, where his birth was witnessed on December 25th by shepherds²⁵.

by the fact that each wears a hat with corks dangling from the rim—in Lord Pacal's case his upper front set of teeth in the decoded picture represent the corks. This ostensibly innocuous point is revealing, because it depicts Lord Pacal and Viracocha in the place of flies, on Earth, the place of filth, which is opposite to the place of purity, Heaven. In so doing it depicts each as the Son of God on Earth. How else could this subtle point be conveyed?

Figure 21a shows one of the Teutons adopting the same raised arm stance. And the Teuton carries a stag in each hand, Jesus to the left, Jesus to the right, and Jesus in the middle.

As we have seen, decoded scenes from the sun shield of Monte Alban reveal that Lord Pacal and Viracocha and Christ were all different incarnations of the Son of God on Earth and analysis of the scenes from the Gundestrup Cauldron appear to be telling the same story about Cernunnos.

The scene showing seated Cernunnos contains even more esoteric information; [here is wisdom, let him that hath understanding count the number of the beast; for it is the number of a man', Revelation XIII, 18]. The number of horns on the antlers that Cernunnos wears on his forehead amounts to 7 on each antler, 7, 7 (figure 22a), and we note that the number 144,000 [the number of the pure]—that appears on the forehead of Lord Pacal in the decoded picture of Lord Pacal (plate 5b and detailed in figure A10)—does so only when the transparencies are each positioned at 7° each from the vertical (7° and 7°). That this information was deliberately intended to be conveyed is confirmed by further numerical analysis of the scene: the real stag, standing next to Cernunnos (figure 22a), does not have 7 horns on each antler; he carries 8 on each (8, 8). The grouping of horns can be further analysed as in figure 22b which shows the numbers 3, 3, 3, 3, 4, 4, and 5, 5 (in addition to the sequences of 7, 7, and 8, 8, from above). The numbers 6, 6, 6 [the number of the beast] are missing from the sequence, as they are in the numerical matrix from the tomb of Lord Pacal (figure A17). The snake that Cernunnos carries in his left hand curiously carries what appears to be the beak of a bird, a duck's bill, extending from the head, or else the creature may be meant to represent a dragon, a mythological composite of a bird, a snake and a stag. Either way, Cernunnos is here associated with the feathered snake (the bird and the snake) of Lord

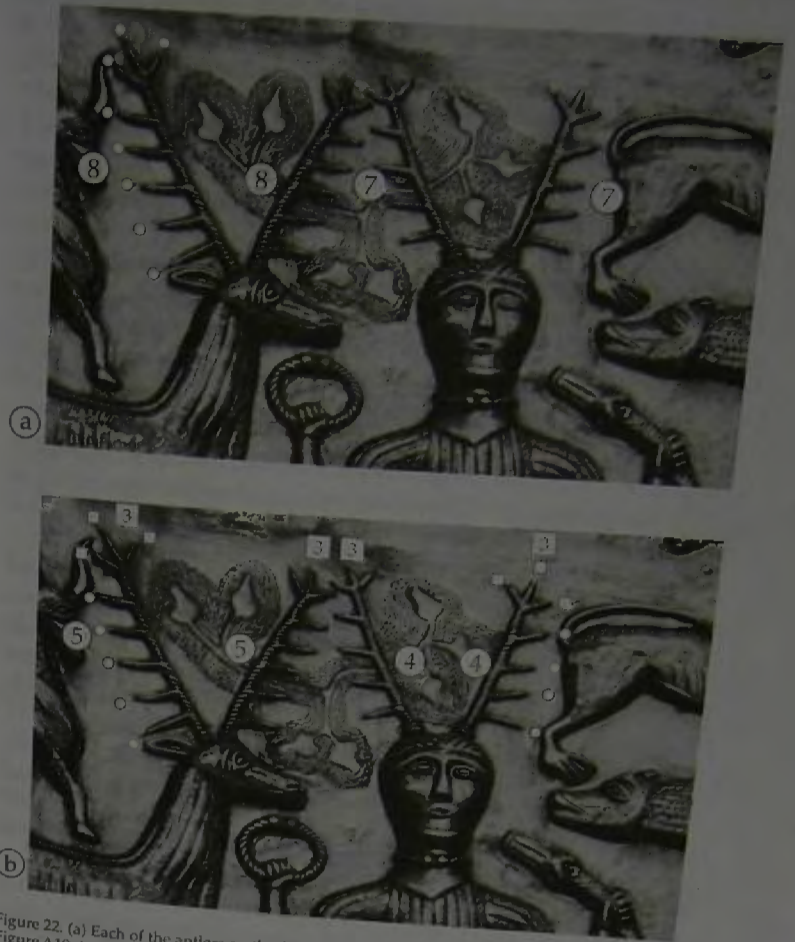

Figure 22. (a) Each of the antlers on the forehead of Cernunnos carries 7 angular horns (7, 7). Figure A10 shows that the number 144,000 [the mark of the pure] only appears on Lord Pacal's forehead when the transparencies are juxtaposed by 7° and 7° (7, 7). Cernunnos hence likewise carries the number 144,000 on his forehead. That this is so is confirmed by further numerical analysis of the numbers in the scene: the real stag, standing next to Cernunnos, does not have 7 horns on each antler, he carries 8 on each (8, 8). The grouping of horns can be further analysed as in (b) which shows the numbers 3, 3, 3, 3, 4, 4 and 5, 5. The numbers 6, 6, 6 [the number of the beast] are missing from the sequence, just as they are in the numerical matrix from the tomb of Lord Pacal (figure A17).

In Ireland the Celtic bull-sacrifice (tarb-feis) was an integral feature of the inauguration of a new king, a ceremony of deep religious significance in Celtic Irish society.

Seven platelets clipped to the outside wall of the cauldron feature a man with raised arms, contemporaneously described as one of the barbarian Teutones that roamed Germany during those times.

The so-called Teutones with raised arms (figure 21a) have more to say: figure 21b shows the man with raised arms that covers the face of Lord Pacal from one of the decoded pictures from the Amazing Lid of Palenque (plate 5b). Figure 21c shows another representation of the same character with raised arms from the tomb of Viracocha in Peru. Both appearances of the small man are characterised and distinguished by the fact that each wears a hat with corks dangling from the rim—in Lord Pacal's case his upper front set of teeth in the decoded picture represent the corks. This ostensibly innocuous point is revealing, because it depicts Lord Pacal and Viracocha in the place of flies, on Earth; the place of filth, which is opposite to the place of purity, Heaven. In so doing it depicts each as the Son of God on Earth. How else could this subtle point be conveyed.

Figure 21a shows one of the Teutones adopting the same raised arm stance. And the Teutone carries a stag in each hand, Jesus to the left, Jesus to the right, and Jesus in the middle.

As we have seen, decoded scenes from the sun shield of Monte Alban reveal that Lord Pacal and Viracocha and Christ were all different incarnations of the Son of God on Earth and analysis of the scenes from the Gundestrup Cauldron appear to be telling the same story about Cernunnos.

The scene showing seated Cernunnos contains even more esoteric information; [here is wisdom, let him that hath understanding count the number of the beast; for it is the number of a man', Revelation XIII, 18]. The number of horns on the antlers that Cernunnos wears on his forehead amount to seven on each antler, 7, 7 (figure 22a) and we note that the number 144,000 [the number of the pure]—that appears on the forehead of Lord Pacal in the decoded picture of Lord Pacal (plate 5b and detailed in figure A10)—does so only when the transparencies are each positioned at 7° each from the vertical (7° and 7°). That this infor-

The Mystery of the Man with Raised Arms



Figure 21. (a) Scene of a man with raised arms, from the Gundestrup Cauldron, shown with two stags, (like Lord Pacal in the Mural of Bonampak, plate 4). (b) Decoded picture of a man, also with raised arms, from Lord Pacal's Amazing Lid of Palenque (plate 5b). (c) Figure of a man with raised arms from the tomb of Viracocha Pachacamac, Peru.

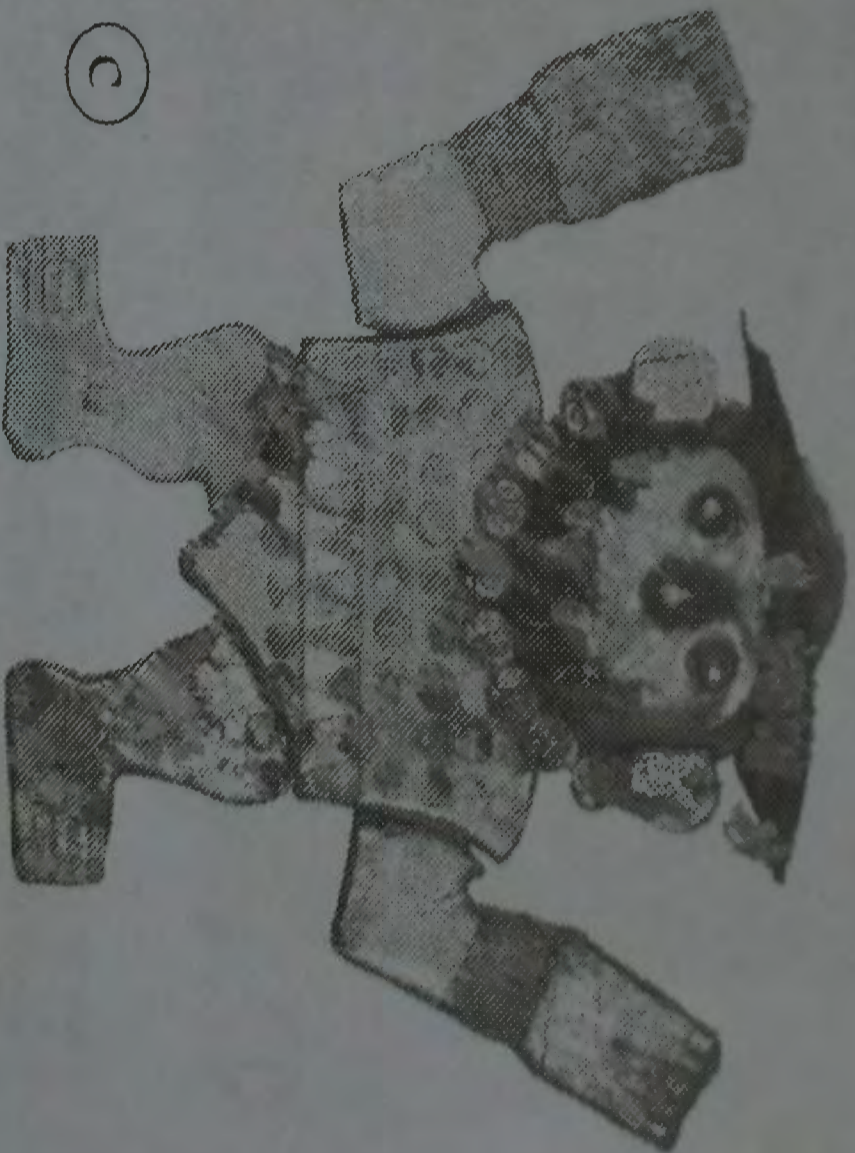
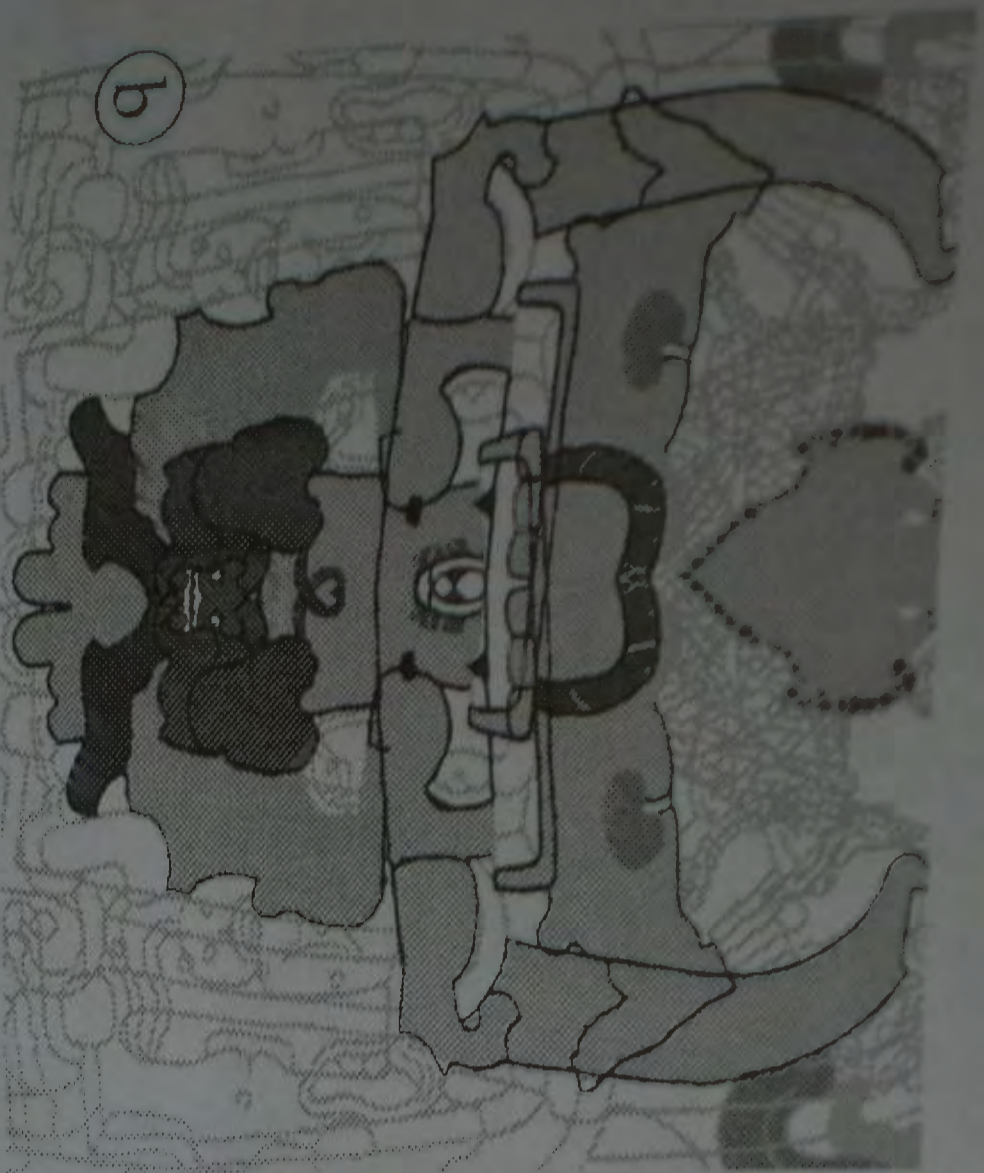

Figure 21. (a) Scene of a man with raised arms, from the Gundestrup Cauldron, shown with two stags, (like Lord Pacal in the Mural of Bonampak, plate 4). (b) Decoded picture of a man, also with raised arms, from Lord Pacal's Amazing Lid of Palenque (plate 5b). (c) Figure of a man with raised arms from the tomb of Viracocha Pachacamac, Peru.

Pacal, Tutankhamun, the Viracochas and Ch'in Shi Huangdi. Hence, on the one hand Cernunnos is the feathered snake (appendix 3) and on the other hand the Sun.

The feathered snake shown in figure A27 appears only when the transparencies of the mosaic jade mask of Lord Pacal, which was found covering his face in his tomb at Palenque, are each rotated by 66.6° and then overlaid. In the same way, Lord Pacal appears as Lord of the Stags in the Mural of Bonampak (plate 4) only when each transparency is rotated by 33.3° each, when they are juxtaposed by 66.6° (in relation to each other) and then overlaid. All of these go to illustrate the importance of the number 666 when encoding information by the ancients into their treasures and the cauldron is no exception.

The March of the Romans

In 486 BC, following the collapse of the hill-forts, the Celtic population spread out from central Europe. As many as 200,000–300,000 crossed the Alps into northern Italy. In 391 BC a group of 30,000 Celts attacked the Etruscan stronghold of Clusium (modern-day Chiusi).

The Etruscan army called upon the support of Rome who responded by sending ambassadors in an effort to mediate. But the ambassadors took sides with the Etruscans forcing Rome to send troops. The coalition fought bravely but were no match for the Celtic 'barbarians' from the north who took the city for themselves and then, gaining in strength and confidence, continued their push southwards into Italy.

In 387 BC the Celts attacked the Roman army on the banks of the River Allia, a tributary of the Tiber, around 16 km (10 miles) north of Rome and, victorious, marched on to sack Rome itself. But this time fate was on the side of Rome; weakened by disease and epidemic, the Celts were persuaded to return north in return for gold. The military defeat shook the Romans who, in response, fortified the capital with a protective wall. The experience, at least for a while, encouraged them to adopt a more conciliatory approach with their neighbours. But it was not to last. Within fifty years the Romans recommenced their aggressive campaigns in pursuit of empire.

By 295 BC they turned the tables on a coalition of Samnite, Etruscan and Italian Celts who they crushed at the battle of Sentenium. The

Celts fled north to consolidate their position. Some shifted southeastwards, into Greece, where they ravaged Delphi in 279 BC and passed to enjoy the spoils of war. But the Greeks, as though in the lap of the gods, helped by earthquakes, thunderstorms and avalanches regained control killing 30,000 Celts. Those that were left dispersed and fled to Turkey. In 225 BC bands of mainland Italian Celts supported by Alpine Celts attacked Rome. But they were no match for the Roman legions who cornered and destroyed them at the battle of Telamon.

The disciplined and organised Roman army grew in strength. By 125 BC it assumed control of Massalia, long since lost to Greek control, giving them a foothold from which they would later advance northwards into France. In 57 BC, under the command of Julius Caesar, the Roman army attacked and slaughtered Celts at Sambre in northeast France, capturing more than 50,000 who were interned into slavery.

In 55 BC Caesar, together with two legions of troops, crossed the English Channel on a mission to ascertain the extent of defences that might oppose a future full-scale invasion. Their presence was quickly detected resulting in skirmishes with local Celts who, subdued with bribes, accepted assurances that the Romans would leave within days, and they did. Two years later Caesar returned, this time with 600 ships carrying 25,000 men. But the Celts, in the meantime, alerted by the first appearance of the Romans, had organised themselves under the leader Cassivellaunus whose troops repelled the Roman invasion and pushed them back to France.

By 52 BC, in response to Roman defeats and subjugation, French Celts had organised themselves into a cohesive fighting force under the Celtic warrior Vercingetorix (d. 46 BC) who launched raids on the Romans in the south. Caesar intercepted, forcing the Celts to retreat to the hill-fort at Alesia (today's Alise-Sainte-Reine in eastern France). There, Caesar's 50,000-strong force besieged the garrison who, half-starved, were unable to breach the Roman lines, even with the help of reinforcements from forty other Celtic tribes that swelled their numbers to over 200,000. Suffering massive casualties, the relief forces withdrew and Vercingetorix surrendered to Caesar. The whole of Gaul was now under the control of Rome. One million Celts were dead and another million were sold as slaves.

The Secrets of Cernunnos

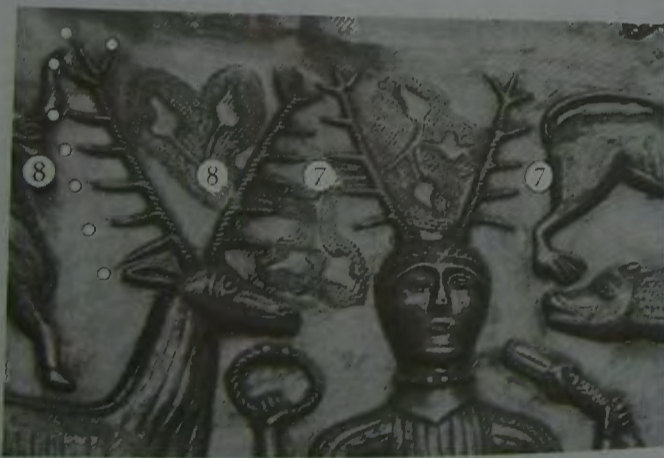

a

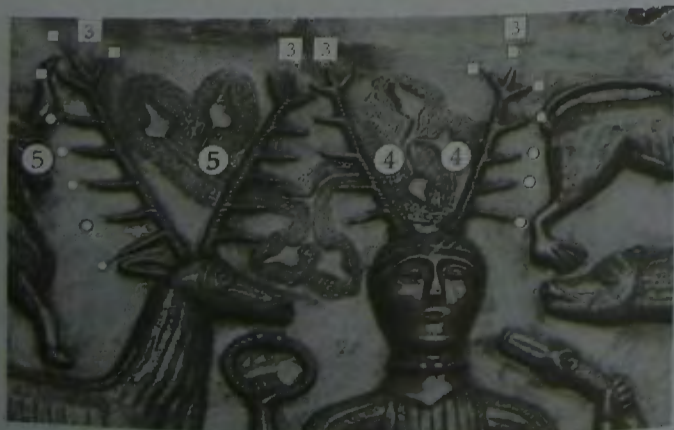

b

Figure 21 (a) (b) The antlers on the forehead of Cernunnos carry seven angular horns (7, 7). The snake's tongue carries the number 144,000 [the mark of the pure] only appears on Lord Pacal's forehead when the transparencies are juxtaposed by 7° and 7° (7, 7). Cernunnos hence likewise carries the number 144,000 on his forehead. That this is so is confirmed by further numerical analysis of the scene; the real stag, standing next to Cernunnos, does not have 7 horns but carries the number 8 on each (8, 8). The grouping of horns can be further analysed under the following sequence, just as they are in the numerical matrix from the tomb of Lord Pacal (figure A20). The sequence, just as they are in the numerical matrix from the tomb of

mation was deliberately intended to be conveyed is confirmed by further numerical analysis of the scene; the real stag, standing next to Cernunnos (figure 21a) does not have 7 horns on each antler, he carries 8 on each (8, 8). The grouping of horns can be further analysed as in figure 22b which shows the numbers 3, 3, 3, 3, 4, 4, and 5, 5 (in addition to the sequences of 7, 7, and 8, 8, from above). The numbers 6, 6, 6 [the number of the beast] are missing from the sequence, as they are in the numerical matrix from the tomb of Lord Pacal (figure A20). The snake that Cernunnos carries in his left hand curiously carries what appears to be the beak of a bird, a duck's bill, extending from the head, or else the creature may be meant to represent a dragon, a mythological composite of a bird, a snake and a stag. Either way, Cernunnos is here associated with the feathered snake (the bird and the snake) of Lord Pacal, Tutankhamun, the Viracochas and Ch'in Shi Huangdi. Hence, on the one hand Cernunnos is the feathered snake (Appendix 3) and on the other hand the Sun.

The feathered snake shown in Figure A27 appears only when the transparencies of the mosaic jade mask of Lord Pacal, which was found covering his face in his tomb at Palenque, are each rotated by 66.6° and then overlaid. In the same way, Lord Pacal appears as Lord of the Stags in the Mural of Bonampak (plate 4) only when each transparency is rotated by 33.3° each, when they are juxtaposed by 66.6° (in relation to each other) and then overlaid. All of these go to illustrate the importance of the number 666 when encoding information by the ancients into their treasures and the cauldron is no exception.

The March of the Romans

In 486 BC, following the collapse of the hill-forts, the Celtic population spread-out from central Europe. As many as 200,000–300,000 crossed the Alps into northern Italy. In 391 BC a group of 30,000 Celts attacked the Etruscan stronghold of Clusium (modern-day Chiusi).

The Etruscan army called upon the support of Rome who responded by sending ambassadors in an effort to mediate. But the ambassadors took sides with the Etruscans forcing Rome to send troops. The coalition fought bravely but were no match for the Celtic 'barbarians' from the north who took the city for themselves and then, gaining in strength and

(a)



(b)

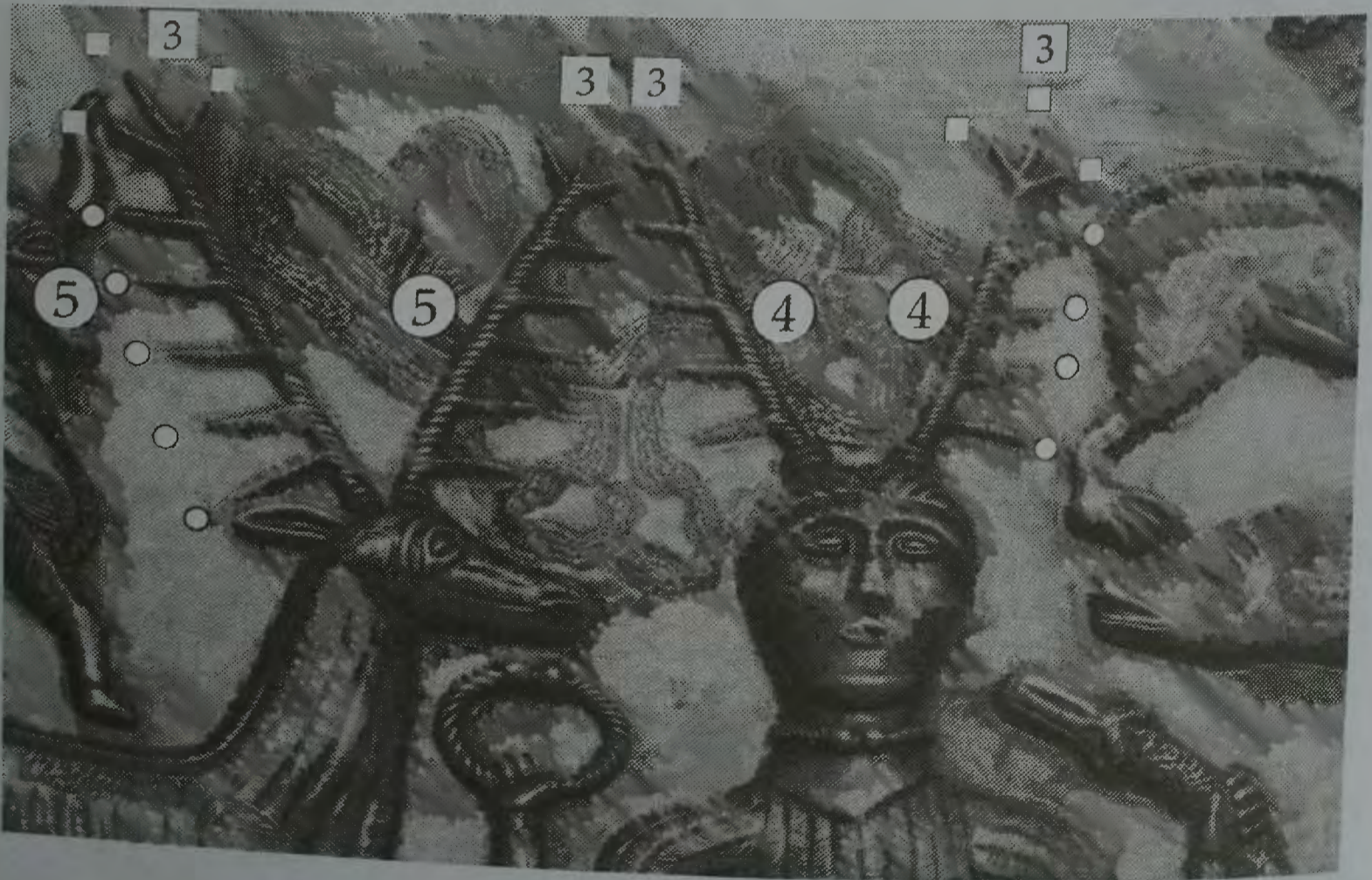

Figure 22. (a) Each of the antlers on the forehead of Cernunnos carry seven angular horns (7, 7). Figure A10 shows that the number 144,000 [the mark of the pure] only appears on Lord Pacal's forehead when the transparencies are juxtaposed by 7^0 and 7^1 (7, 7). Cernunnos hence likewise carries the number 144,000 on his forehead. That this is so is confirmed by further numerical analysis of the numbers in the scene; the real stag, standing next to Cernunnos, does not have 7 horns on each antler, he carries 8 on each (8, 8). The grouping of horns can be further analysed as in (b) which shows the numbers 3, 3, 3, 3, 4, 4 and 5, 5. The numbers 6 6 6 [the number of the beast] are missing from the sequence, just as they are in the numerical matrix from the tomb of Lord Pacal (figure A17).

The Druids

The Roman conquest of Britain began in AD 43 during the reign of Emperor Claudius and lasted for more than forty years. In the latter years (during the reign of Emperor Domitian), the Governor Agricola took the campaign north to Scotland but after several unsuccessful attempts to conquer the country fixed the frontier with a boundary that spanned England between the Rivers Solway and Tyne.²⁶ Roman colonies established themselves at London, York, Chester, St. Albans, Lincoln, Gloucester, Bath, Chester, Manchester and Colchester. It was at Colchester in AD 60 that Celtic troops led by Boudicca (d. AD 61) rallied and revolted against Roman imperialistic rule without success. Eighty thousand Celts were killed. It put paid to Celtic resistance against the Romans throughout Britain, except for die-hard stoical Druids who defended their religious centre at Ynys Môn on the island of Anglesey in Wales until that too was destroyed by the Romans in around AD 70.

Druidism (from the Greek, *drus*, 'oak' tree) was the outlawed religion of the Celts in Roman Gaul, and in Britain where it originated. The oak was so revered because it sustained the parasitic plant mistletoe that bears translucent white berries that epitomise fertility, the soul [the seed within] and Venus—the white planet of love.²⁷

The Druids, like the Maya, Egyptians, Peruvians and Chinese, were sun-worshipping astronomer-priests who believed in the immortality of the soul, reincarnation (transmigration of the soul) and astrology. The Druidic year of only 354 days (twelve lunar months of 29.5 days) referred to auspicious and inauspicious days and could be used to predict the best times for planting and harvesting. In 1897 a bronze example of a Druidic calendar used during the reign of the first Roman emperor, Augustus (63 BC–AD 14), was found at Coligny, near Bourgen-Bresse, France, demonstrating that Druidism was practised at that time. The calendar lists sixty-two months over a five-year period and concerns itself with movements of the Sun and Moon. Good days were described as 'mat' and bad days as 'anm'.

Many Classical writers wrote about Druidic ritual and practice. Strabo (63 BC–AD 21), Athenaeus (c. AD 200), Diodorus (AD 60–30) and Caesar (100–44 BC) base their evidence on the earlier works of Posidonius. Much is learned from Pliny the Elder and in his *Historia Naturalis* (Natural History) of AD 77 he suggests that Druidism origi-

confidence, continued their push southwards into Italy.

In 387 BC the Celts attacked the Roman army on the banks of the River Allia, a tributary of the Tiber, around 16km (10 miles) north of Rome and, victorious, marched on to sack Rome itself. But this time fate was on the side of Rome; weakened by disease and epidemic the Celts were persuaded to return north in return for gold. The military defeat shook the Romans who, in response, fortified the capital with a protective wall. The experience, at least for a while, encouraged them to adopt a more conciliatory approach with their neighbours. But it was not to last. Within 50 years the Romans recommenced their aggressive campaigns in pursuit of empire.

By 295 BC they turned the tables on a coalition of Samnite, Etruscan and Italian Celts who they crushed at the battle of Sentenium. The Celts fled north to consolidate their position. Some shifted south-eastwards, into Greece, where they ravaged Delphi in 279 BC and paused to enjoy the spoils of war. But the Greeks, as though in the lap of the Gods, helped by earthquakes, thunderstorms and avalanches regained control killing 30,000 Celts. Those that were left dispersed and fled to Turkey. In 225 BC bands of mainland Italian Celts supported by Alpine Celts attacked Rome. But they were no match for the Roman legions who cornered and destroyed them at the battle of Telamon.

The disciplined and organised Roman army grew in strength. By 125 BC it assumed control of Massalia, long since lost to Greek control, giving them a foothold from which they would later advance northwards into France. In 57 BC, under the command of Julius Caesar, the Roman Army attacked and slaughtered Celts at Sambre in Northeast France, capturing more than 50,000 who were interned into slavery.

In 55 BC Caesar, together with two legions of troops, crossed the English Channel on a mission to ascertain the extent of defences that might oppose a future full-scale invasion. Their presence was quickly detected resulting in skirmishes with local Celts who, subdued with bribes, accepted assurances that the Romans would leave within days, and they did. Two years later Caesar returned, this time with 600 ships carrying 25,000 men. But the Celts, in the meantime, alerted by the first appearance of the Romans, had organised themselves under the leader Cassivellaunus whose troops repelled the Roman invasion and pushed

nated from the Magi, the wise men of Persia who as priests were aware of the higher orders of magic. Strabo associates them with the shamans of antiquity who appear in cave paintings made during the hunting period of c. 30,000 BC. Shamans, some of whom survive today, believe that every living thing has 'spirit', in the same way that modern science acknowledges that all tangible things are comprised of atoms that are held together by the *strong nuclear force* (that binds the nucleus of the atom together) and the *weak nuclear force* (that holds the outer negative electrons in orbit around the nucleus).

In those days the shaman was able to locate quarry through sense and to leave his body at will, to have an out-of-body experience and visit the soul world—a gift useful to pacify and bless the departing souls of animals and so avoid karmic retribution.²⁸

We can be sure that whenever human sacrifice is mentioned in the context of sun-worshipping civilizations, the reporters are unfamiliar with the real reason for the killing which undoubtedly took place. In Mexico, the Maya believed that this Earth is Hell (figures A18, A19 and A20) and that the only way to escape from Hell was to die either in sacrifice or in duty-inspired death—through battle. The strongest and finest of athletes, invariably soldiers, could compete in the national ball game, which involved hitting a small ball through hoops located high up on either side of the stadium. The hoops represented the twin manifestations of Venus in the sky. As a reward the winners were killed, escaped from Hell (the Earth) and travelled to Paradise. Thus they were made sacred, sacrificed. Others simply died naturally, without purpose, to reincarnate over and over again. In this way sacrifice was rationalised as a sign of love, a means of escape from Hell, and compassion. (Appendix 2 describes what the soul is and how it gets to Heaven).

The Maya were also preoccupied with the fertility-inspiring effects of the Sun, which at that time was failing the fertility needs of the people. They left behind stone carvings showing ostensible bloodletting practices. But there is more to the carvings than a senseless portrayal of masochism; they were attempting to convey the message that the Sun was failing their fertility needs, failing the production of oestrogen and progesterone, failing menstruation (blood). The Aztecs, who came later, misunderstood the message, lost the plot and slaughtered

them back to France.

By 52 BC, in response to Roman defeats and subjugation, French Celts had organised themselves into a cohesive fighting force under the Celtic warrior Vercingetorix (d. 46 BC) who launched raids on the Romans in the south. Caesar intercepted, forcing the Celts to retreat to the hill-fort at Alesia (today's Alise-Sainte Reine in eastern France). There, Caesar's 50,000 strong force besieged the garrison who, half-starved, were unable to breach the Roman lines, even with the help of reinforcements from forty other Celtic tribes that swelled their numbers to over 200,000. Suffering massive casualties the relief forces withdrew and Vercingetorix surrendered to Caesar. The whole of Gaul was now under the control of Rome. One million Celts were dead and another million were sold as slaves.

The Druids

The Roman conquest of Britain began in AD 43 during the reign of Emperor Claudius and lasted for more than 40 years. In the latter years, (during the reign of Emperor Domitian), the Governor Agricola²⁶ took the campaign north to Scotland but after several unsuccessful attempts to conquer the country fixed the frontier with a boundary that spanned England between the Rivers Solway and Tyne. Roman colonies established themselves at London, York, Chester, St Albans, Lincoln, Gloucester, Bath, Chester, Manchester and Colchester. It was at Colchester in AD 60 that Celtic troops led by Boudicca (d. AD 61) rallied and revolted against Roman imperialistic rule without success. 80,000 Celts were killed. It put paid to Celtic resistance against the Romans throughout Britain, except for die-hard stoical Druids who defended their religious centre at Ybys Môn on the Island of Anglesey in Wales until that too was destroyed by the Romans in around AD 70.

Druidism (from the Greek, *drus*, 'oak' tree) was the outlawed religion of the Celts in Roman Gaul, and in Britain where it originated. The oak was so revered because it sustained the parasitic plant mistletoe that bears translucent white berries that epitomise fertility, the soul [the seed within] and Venus—the white planet of love.²⁷

The Druids, like the Mayas, Egyptians, Peruvians and Chinese, were sun-worshipping astronomer-priests who believed in the immortality of

millions needlessly. Accounts from Classical writers and from archaeological remains indeed suggest that human sacrifice took place among the Druids but no evidence remains that might explain why. The real reason no doubt lies somewhere between the accounts of the Maya and Aztecs. It was this belief in transmigration of the soul (reincarnation), a promise of a place in Paradise, that made the Celts such fearless fighters, eager to die in battle, as noted by Julius Casesar who questioned the source of their courage:

They wish to inculcate this as one of their leading tenets; that souls do not become extinct, but pass after death from one body to another, and they think that men by this tenet are in a great degree excited to valour, the fear of death being disregarded. (*Gallic War*, Wm. A. McDevitt [trans.], Book VI, p. 14)

Lucanus adds:

From you [the Druids] we learn that the destination of man's spirit is not the grave nor the Kingdom of the Shades. The same spirit in another world animates a body and if your teaching be true, death is the centre, not the finish of a long life. (*Pharsalia* [c. 48 BC], Loeb, 1962)

The word Maya derives from the ancient Indian Sanskrit word Maya, meaning illusion. The Maya of Central America adopted it because they believed that this physical world could only adequately be described as illusion. These master astronomers and timekeepers believed that time was the key to understanding all physical existence. A beautiful flower, for example, gently cupped between the fingers of the hand, appears to be a flower. It smells like a flower, it feels like a flower, it looks like a flower, and it tastes like a flower, therefore it must be a flower. But therein lies the illusion. In reality the flower is actually a combination of physical elements: atoms, molecules and DNA, bound together with electrical energy. In common with the human body, the flower, as it grows, develops physical systems that in turn generate electrical activity. That electrical energy then attracts electrical energy (with a charge equal and opposite to itself) from outside of itself, meaning that plants, in common with people and all living things, contain an electrical charge acquired from outside of itself, a soul. So the Godly

energy inside the flower is at one moment in time only inside the flower. At another moment in time, perhaps four weeks later, the DNA in the flower will have begun to decompose. The electrical charge will be released and will transmigrate to another collection of DNA which is beginning to live (beginning to attract a soul from outside of itself), perhaps to the DNA of a developing butterfly or worm or dog. The soul therefore is only in disguise at any one moment in time, which means that everything around us is illusion. This is to say that everything around us is a manifestation of God, in either a physical form or an energy form. The flower is not a flower, it only appears to be a flower; it is actually God in disguise.

This way of looking at the world explains away life's imponderables, why we live, why we die and why this has to be. Soul energy that has increased in voltage (figure A20) during its time in the physical world rises up the energy chain, each time transmigrating into a higher-voltage collection of physical cells: from plant, to insect, to animal to man. High-voltage souls return to God when the body dies. In this way God grows, which is seen as good, because 'God is good'. The Universe grows. In this scheme low-voltage souls return to lower-voltage collections of developing physical cells.

The Druids must have acquired the super-science of the Sun and the higher orders of spirituality from a Supergod teacher who lived during the earliest of times, perhaps the King of Hochdorf of c. 550 BC.

But the teachings go back further in time; the timber piles that depict the radiating solar wind, near the tombs in the Taklamakan Desert, and the adoption of the solar cross by the Celts means that the Celts must have been aware of the super-science of the Sun as early as 2000 BC. In Europe the earliest artefacts to surface appeared in around 800 BC, in Ireland. Figure 23a shows a pair of Irish copper plates, from around 800 BC,²⁹ that depict the cross-sectional nature of the Sun's magnetic fields and figure 23b shows in some detail that sunspots, and the effect they have on life on Earth, must have been important to the people of the time. Figure 24 shows a golden Celtic 'necklet', one of more than eighty discovered so far. The necklet takes the shape of a modern-day lunula astronomical calculator. Whether the golden lunulae were actually used as part of a pre-historic navigation regime or purely decorative is not known.

THE CELTIC CHRONICLES

the soul, reincarnation (transmigration of the soul) and astrology. The Druidic year of only 354 days (12 lunar months of 29.5 days) referred to auspicious and inauspicious days and could be used to predict the best times for planting and harvesting. In 1897 a bronze example of a Druidic calendar used during the reign of the first Roman Emperor, Augustus (63 BC-AD 14), was found at Coligny, near Bourg-en-Bresse, France, demonstrating that Druidism was practised at that time. The Calendar lists 62 months over a five-year period and concerns itself with movements of the Sun and Moon. Good days were described as 'mat' and bad days as 'anm'.

Many Classical writers wrote about druidic ritual and practice. Strabo (63 BC-AD 21), Athenaeus (c. AD 200), Diodorus (AD 60-30) and Caesar (100-44 BC) base their evidence on the earlier works of Posidonius. Much is learned from Pliny the Elder and in his *Historia Naturalis*. [Natural History] of AD 77 he suggests that Druidism originated from the Magi, the wise men of Persia who as priests were aware of the higher orders of magic. Strabo associates them with the Shamans of antiquity who appear in cave paintings made during the hunting period of c. 30,000 BC. Shamans, some of whom survive today, believe that every living thing has 'spirit', in the same way that modern science acknowledges that all tangible things comprise of atoms that are held together by the *strong nuclear force* (that binds the nucleus of the atom together) and the *weak nuclear force* (that holds the outer negative electrons in orbit around the nucleus).

In those days the Shaman was able to locate quarry through sense and to leave his body at will, to experience an out-of-body experience and visit the soul world—a gift useful to pacify and bless the departing souls of animals and so avoid karmic²⁸ retribution.

We can be sure that whenever human sacrifice is mentioned in the context of sun worshipping civilizations that the reporters are unfamiliar with the real reason for the killing which undoubtedly took place. In Mexico, the Maya believed that this Earth is Hell (figures A18, A19 and A20) and that the only way to escape from Hell was to die either in sacrifice or in duty-inspired death—through battle. The strongest and finest of athletes, invariably soldiers, could compete in the National ball game, which involved hitting a small ball through hoops located high up

on either side of the stadium. The hoops represented the twin manifestations of Venus in the sky. As a reward the winners were killed, escaped from Hell (the Earth) and travelled to Paradise. Thus they were made sacred, sacrificed. Others simply died naturally, without purpose, to reincarnate over and over again. In this way sacrifice was rationalised as a sign of love, a means of escape from Hell, and compassion. (Appendix 2 describes what the soul is and how it gets to Heaven).

The Maya were also preoccupied with the fertility inspiring effects of the Sun, which at that time was failing the fertility needs of the people. They left behind stone carvings showing ostensible blood letting practices. But there is more to the carvings than a senseless portrayal of masochism; they were attempting to convey the message that the Sun was failing their fertility needs, failing the production of oestrogen and progesterone, failing menstruation (blood). The Aztecs, who came later, misunderstood the message, lost the plot and slaughtered millions needlessly. Accounts from Classical writers and from archaeological remains indeed suggest that human sacrifice took place among the Druids but no evidence remains that might explain why. The real reason no doubt lies somewhere between the accounts of the Maya and Aztecs. It was this belief in transmigration of the soul (reincarnation), a promise of a place in Paradise, that made the Celts such fearless fighters, eager to die in battle, as noted by Julius Casesar who questioned the source of their courage:

They wish to inculcate this as one of their leading tenets; that souls do not become extinct, but pass after death from one body to another, and they think that men by this tenet are in a great degree excited to valour, the fear of death being disregarded (*Gallic War*, Wm. A. McDevitt [trans.] Book VI, p. 14).

Lucanus adds:

From you [the Druids] we learn that the destination of man's spirit is not the grave nor the Kingdom of the Shades. The same spirit in another world animates a body and if your teaching be true, death is the centre, not the finish of a long life (*Pharsalia*, [c. 48 BC], Loeb, 1962).

The word Maya derives from the ancient Indian Sanskrit word of Maya,

Celtic Astronomy (I)
The Sectored Structure of the Solar Wind
and Sunspots

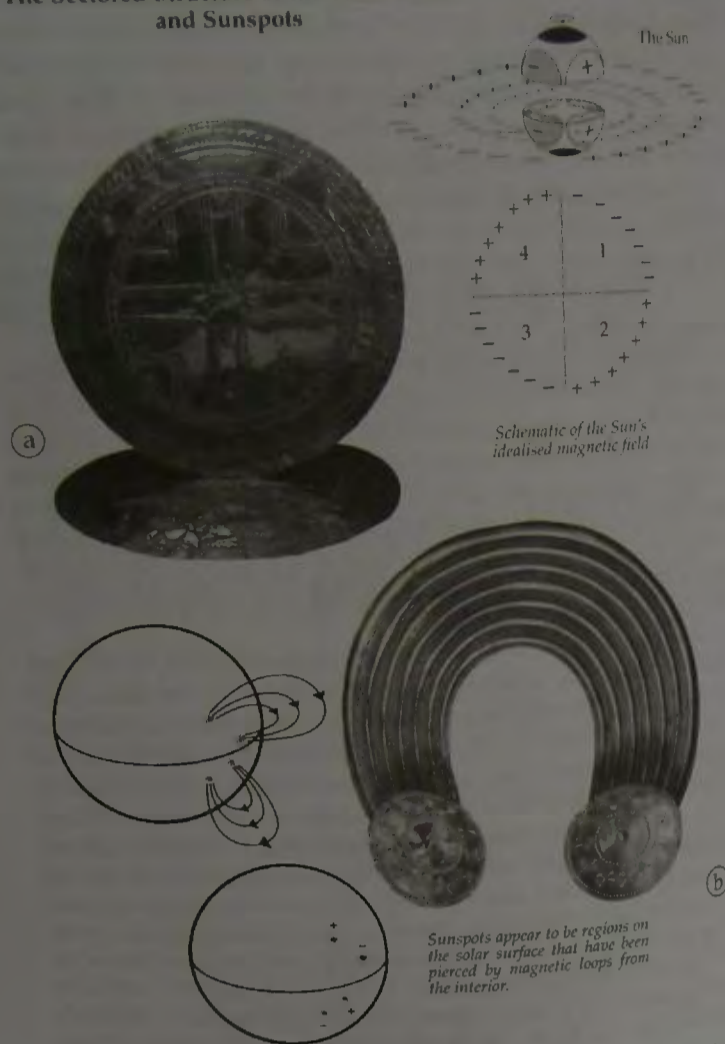

Figure 23. (a) Celtic golden Sun discs depicting the sectored structure of the Sun's magnetic fields (Ireland, west coast, c. 800 BC). (b) The Gleninsheen gorget (Ireland, west coast, c. 800 BC). A Celtic so-called golden neck-collar showing magnetic bursts from sunspots on the Sun's surface. The Celts understood the super-science of the Sun and the higher orders of spirituality.

meaning illusion. The Maya of Central America adopted it because they believed that this physical world could only adequately be described as illusion. These master astronomers and timekeepers believed that time was the key to understanding all physical existence. A beautiful flower, for example, gently cupped between the fingers of the hand, appears to be a flower. It smells like a flower, it feels like a flower, it looks like a flower, and it tastes like a flower, therefore it must be a flower? But therein lies the illusion. In reality the flower is actually a combination of physical elements; atoms, molecules and DNA, bound together with electrical energy. In common with the human body, the flower, as it grows, develops physical systems that in turn generate electrical activity. That electrical energy then attracts electrical energy (with a charge equal and opposite to itself) from outside of itself. Meaning that plants, in common with people and all living things, contain electrical charge acquired from outside of itself, a soul. So the Godly energy inside the flower is at one moment in time only inside the flower. At another moment in time, perhaps 4 weeks later, the DNA in the flower will have begun to decompose and rot. The electrical charge will be released and will transmigrate to another collection of DNA which is beginning to live (beginning to attract a soul from outside of itself), perhaps to the DNA of a developing butterfly or worm or dog. The soul therefore is only in disguise at any one moment in time, which means that everything around us is illusion. This is to say that everything around us is a manifestation of God, either in a physical form or an energy form. The flower is not a flower, it only appears to be a flower, it is actually God in disguise.

This way of looking at the world explains-away life's imponderables, why we live, why we die and why this has to be. Soul energy that has increased in voltage during (figure A20) its time in the physical world rises up the energy chain, each time transmigrating into a higher voltage collection of physical cells; from plant, to insect, to animal to man. High voltage souls return to God when the body dies. In this way God grows, which is seen as good, because 'God is good'. The Universe grows. In this scheme low voltage souls return to lower voltage collections of developing physical cells.

The Druids must have acquired the super-science of the Sun and the higher orders of spirituality from a Supergod teacher who lived during

Celtic Astronomy (II)
Lunula

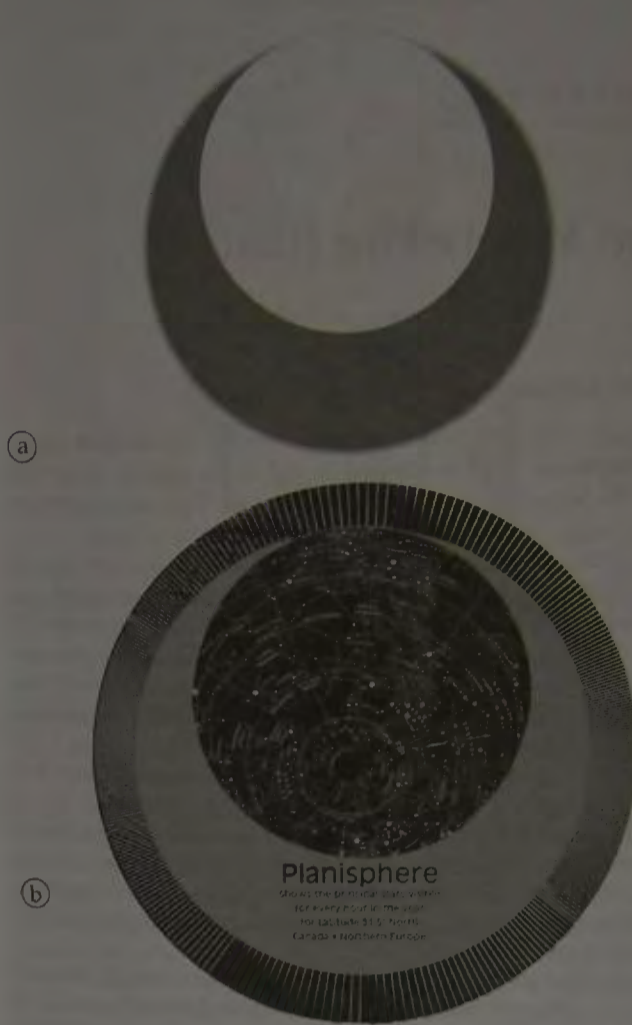

Figure 24. (a) Sketch of Celtic golden 'Ross' Lunula (Ireland, west coast, c. 800 BC), one of more than eighty found in Ireland to date. The piece is so named after the night-time lunar rise and set astronomical calculator (b) used in navigation.

Celtic Astronomy (I)
The Sectored Structure of the Solar Wind
and Sunspots

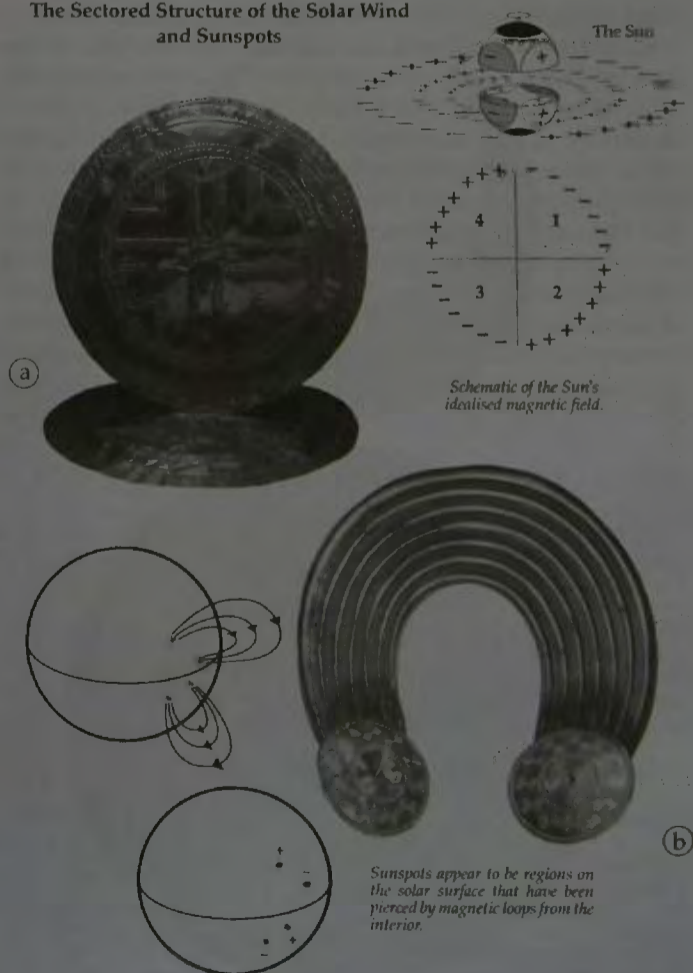

Figure 23. (a) Celtic golden Sun discs depicting the sectored structure of the Sun's magnetic fields (Ireland, west coast c. 800 BC). (b) The Gleninsheen Gorget (Ireland, west coast c. 800 BC). A Celtic so-called golden neck-collar showing magnetic bursts from sunspots on the Sun's surface. The Celts understood the super-science of the Sun and the higher orders of spirituality.

Celtic Astronomy (I)
The Sectorised Structure of the Solar Wind
and Sunspots

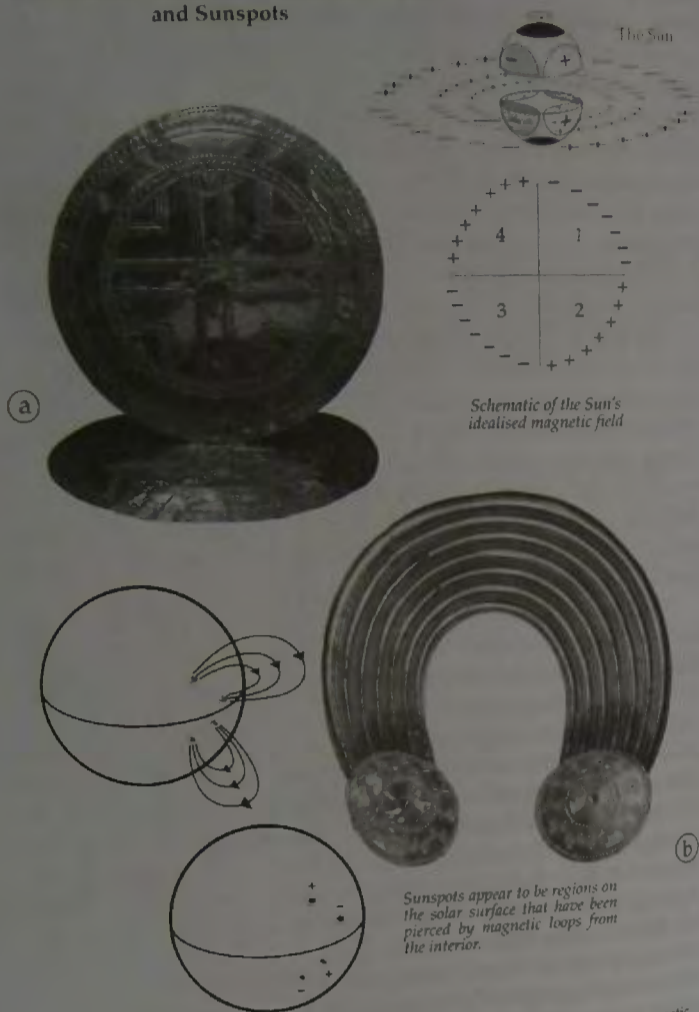

Figure 23. (a) Celtic golden Sun discs depicting the sectorised structure of the Sun's magnetic fields (Ireland, west coast, c. 800 BC). (b) The Gleninsheen gorget (Ireland, west coast, c. 800 BC). A Celtic so-called golden neck-collar showing magnetic bursts from sunspots on the Sun's surface. The Celts understood the super-science of the Sun and the higher orders of spirituality.

Celtic Astronomy (II)
Lunula

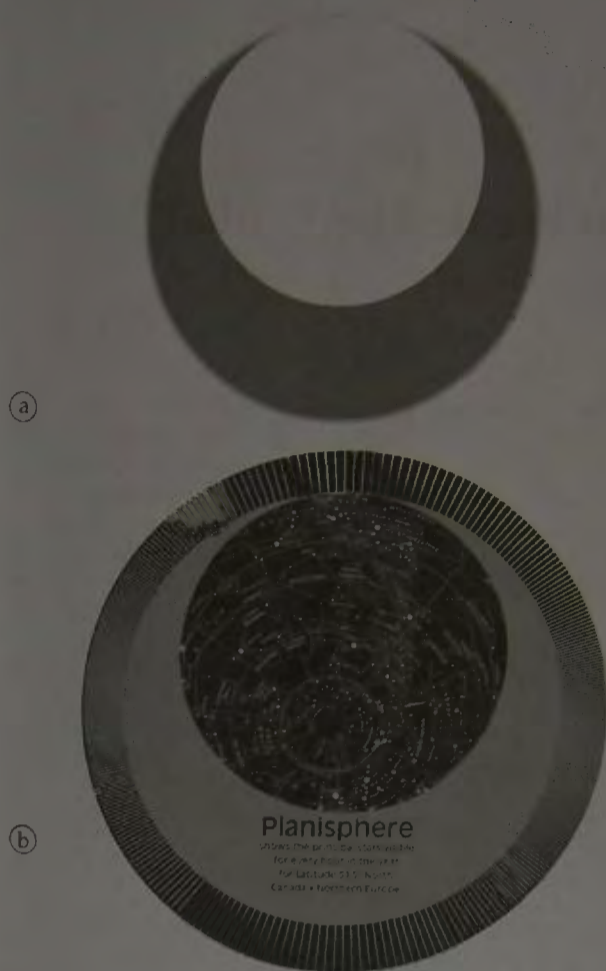

Figure 24. (a) Sketch of Celtic golden 'Ross' Lunula (Ireland, west coast, c. 800 BC, one of more than eighty found in Ireland to date. The piece is so named after the night-time lunar rise and set astronomical calculator (b) used in navigation.

Celtic Astronomy (II)
Lunulae

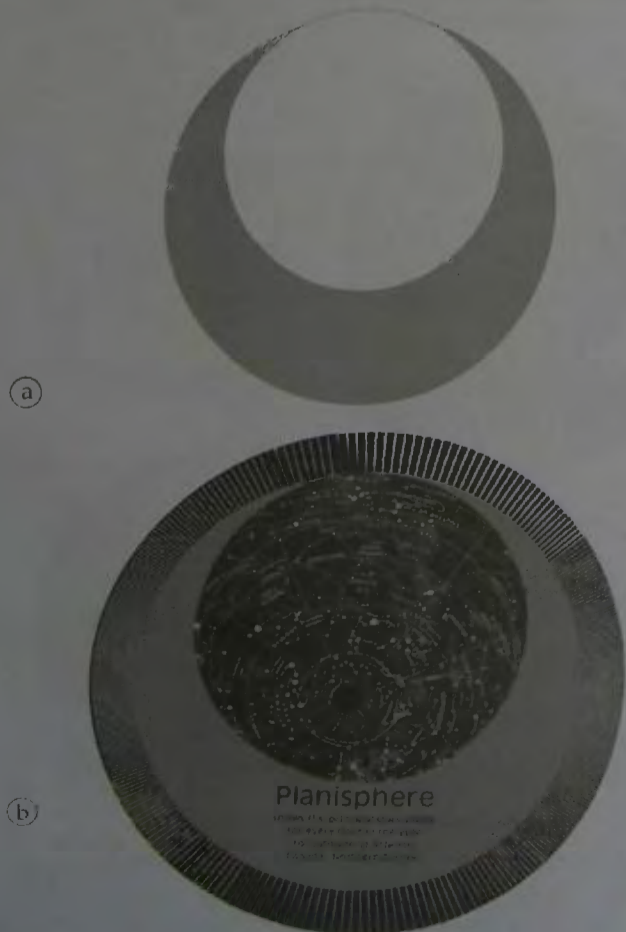

Figure 24. (a) Sketch of Celtic golden 'Ross' Lunula (Ireland, west coast, c. 800 BC, one of more than 80 found in Ireland to date. The piece is so named after the night-time lunar rise and set astronomical calculator (b) used in navigation.

the earliest of times; perhaps the King of Hochdorf of c. 550 BC.

But the teachings go back further in time; the timber piles that depict the radiating solar wind, near the tombs in the Taklamakan desert, and the adoption of the solar-cross by the Celts means that the Celts must have been aware of the super-science of the Sun as early as 2000 BC. In Europe the earliest artefacts to surface appeared in around 800 BC, in Ireland. Figure 23⁹ shows a pair of Irish copper plates, from around 800 BC, that depict the cross-sectional nature of the Sun's magnetic fields and figure 23b shows in some detail that sunspots, and the effect they have on life on Earth, must have been important to the people of the time. Figure 24 shows a golden Celtic 'necklet', one of more than 80 discovered so far. The necklet takes the shape of a modern-day lunula astronomical calculator. Whether the golden lunulae were actually used as part of a pre-historic navigation regime or were purely decorative is not known.

Notes

- 1 In Critias and Timaeus c. 355 BC.
- 2 The Greek statesman c. 638 BC.
- 3 From the Greek word Keltói—the 'secret people'.
- 4 The language derives from four main groups of a branch of Indo-European and is spoken in most of Europe. Gaulish and its close relatives Lepontic, Noric and Galatian were once spoken in a wide arc from France to Turkey and from the Netherlands to Italy and Celtiberian, once spoken in Spain, are now long obsolete. The third in the group the Brythonic, or P-Celtic, is spoken by the Welsh, Cornish, Bretons and Gauls [of France] whereas the Goidelic, or Q-Celtic, is spoken by the Irish [Gaelic, from the association with the French, Gaul], the Scots and the Manx of the Isle of Man. The extinct and the contemporaneous are often classified as two branches, but competing schemes prefer different combinations.
- 5 Deoxyribonucleic acid—the giant molecule that makes the building blocks of bioorganisms.
- 6 The Germanic invaders who conquered much of Britain between the 5th and 7th centuries and who pushed the Celts westwards across Britain.
- 7 Believed to have been compiled between 1056 and 1092. The Inisfallen monastery was established in around AD 650 on the 23-acre island of Inisfallen [the modern day spelling differs slightly] in the lower Killarney Lake, County Kerry, Ireland. The transcript of the Annals, up to 1092, is believed to have been used at a monastery at Lismore and compiled from earlier documents maintained at the monastery of Emly. It was probably continued at Lismore until between around 1130 to 1159 when it was passed to south Munster, probably Inisfallen where it was continued until 1214 and also between 1258 and 1285.
- 8 North-west of the Black Sea between the Carpathian Mountains and the River Don.
- 9 There were five sons of Mil altogether: Éremón, Donn, Ir, Éber and another (the name



Planisphere

shows the principal stars visible
for every hour in the year
for Latitude 51.5° North
Canada • Northern Europe

(a) Sketch of Celtic golden 'Ross' Lunula (Ireland, west coast, c. 800 BC, one of many found in Ireland to date. The piece is so named after the night-time lunar rise astronomical calculator (b) used in navigation.

CHAPTER TWO

Who Wrote the Bible?

The Old Testament

As the early Celts migrated westwards from the Taklamakan Desert, tribal settlements were developing in the fertile valleys of the Nile and on the Sumerian plains between the rivers Tigris and Euphrates between today's Iraq and Iran, and in Canaan [today's Israel].

Abraham, the founding father in Jewish history, was born in around 1900 BC in Ur, Sumeria (figure 25). The Bible says that God told Abraham to lead the Hebrew tribes out of Sumer to escape the famine of the times. Together they followed the Euphrates upstream and crossed the desert to Egypt. At first the Egyptians tolerated their presence but in the years that followed they succumbed to slavery in a land where the natives worshipped a variety of gods.

Beliefs competed for supremacy in regard to which system best explained how the world was created, what forces controlled nature, which prayers and practises offered the best protection against malevolent forces and what might be the best ways to maximise prosperity. In time, tribes grouped together for protection as well as for economies of scale that accommodated efficient planting and harvesting of crops, food storage and transportation.

Unification of Egypt began under the reign of King Narmer in around 3000 BC³⁰—the first of a line of pharaohs that continued through thirty dynasties until 525 BC. With unification the diversity of gods became structured leading to a hierarchy in polytheistic belief. The many gods, though, now reported to a principal god Atum, or Ra,

54

Sumerian Civilisation

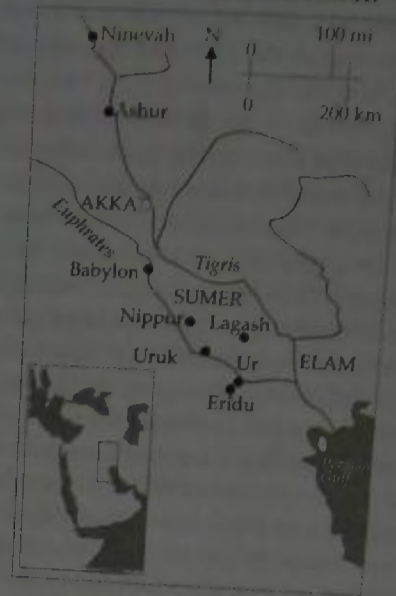

Figure 25. Mesopotamia lies between the rivers Tigris and Euphrates in present-day Iraq. The civilizations of Sumer, c. 3500 BC, and Babylon, c. 609 BC, flourished here.

the Sun God who created the Earth and the heavens. He controlled the lesser gods who in turn managed the elements on Earth, the air, earth and water. He also controlled the sky god Osiris, the god of resurrection and afterlife who lived in the constellation of Orion. It was from here that the notion of body and soul emerged with the belief that this earthly existence merely sustained the body for a short time and could be followed by a heavenly extension that sustained the soul—for millions and millions of years; pure souls would be reborn in the stars and impure ones returned to Earth for another attempt at spiritual purification. This new concept of 'reincarnation' called for a disciplined heart, mind and body. At the same time the polytheistic pantheon of gods, under the control (for the first time) of a single supreme creator God (Ra), meant that monotheism—one-god worship—had in effect established itself without even a single shot being fired.

55

THE CELTIC CHRONICLES

of the fifth does not appear in the translation because of damage to the original manuscript). Éber was born in Egypt, Donn was born in Scythia and Ir and Éremon, the youngest two, were born in Spain.

- 10 The Annals state that the 'Scott' were converted to the Christian faith [in AD 433]. *The Encyclopaedia of Ireland* [under the heading of 'Scotland, links with'] says that later 'an expedition led by the three sons of Erc from Irish Dal Rada (in County Antrim, Ireland) founded the Kingdom of Argyll (now Scotland) in around AD 500'. Hence the origin of Ir-land (after Ir the son of Mil) and Scotland (after Scotta, the Pharaoh's daughter).
- 11 So named after Hall, the Celtic word for salt, and starr the Celtic word for place.
- 12 *The Tutankhamun Prophecies* sets out in detail just how the 28-day solar radiation cycle correlates with variations in fertility hormones.
- 13 Paleomagnetic evidence, from Pearson and Cox (*Climate and Evolution*, 1978) and tree ring data from Bucha, 1970 [both documented in *The Mayan Prophecies*] suggest that the Sun's magnetic field shifted in 3113 BC and again in around AD 620 (1,366,040 days after the 3113 BC shift). It appears that the magnetic twist of AD 620 was of insufficient strength to tilt any of the planets off their axis but did result in adverse radiation from the Sun that deleteriously affected the Earth (see main text).
- 14 Areas around the Earth's Equator are struck by more perpendicular solar X-rays and are hence more affected.
- 15
 - They were all born through an Immaculate Conception.
 - Buddha's mother's name was Maya. Maya was also the name of the architect of Tutankhamun's tomb and also the name of his wet-nurse. The word Maya means 'illusion' in ancient Sanskrit.
 - Maya was a culture that flourished in Mexico c. 100-750 AD and Lord Pacal, the priest-king leader of the Maya, taught that this life was illusion.
 - Krishna is the Greek word for the 'anointed one' and Christ anointed (baptised) others.
 - Jesus is known as the Son of God [from the Tibetan Chi (godly energy) and the Greek Zeus, the creator God, Chi Zeus, the Son of God who died c. 32 BC. *The Bible* says: '...the angel of the Lord appeared unto Joseph in a dream saying ... M a r y shall bring forth a son and his name shall be Chi Zeus'. Matthew I, 20-21]; The name Tutankhamun translates into 'the living Image of God'—the Son of God—and Chi'in Shu Huangdi, the first Emperor of unified China, was known to his people as the 'Son of Heaven'.
 - Stories left behind by Lord Pacal (from the Mural of Bonampak) say that he was the Lord of Sacrifice who died on a cross made from two pieces of wood. Jesus died on the cross at Easter and the Roman Catholic word for Easter is Paschal.
 - Viracocha is the Quechua word for 'foam of the sea', a metaphor for the perfect human being. A person in 'the foam of the sea' is simultaneously in contact with all of the Earth's elements of earth, air, fire and water; the earth, beneath the feet, the air, the fire (the Sun) that shines on the face, and the water. Any movement towards the sea causes loss of contact with the earth, and the water. Any movement towards land causes loss of contact with the water. Hence, a person reaches perfection only in the 'foam of the sea'. A 60cm (2-foot) high golden anthropomorphic figure of a crab-man (plate 5d) was found in the tomb of Viracocha at Sipan in Peru. The crab is a creature that lives on the land and in the sea, in the foam of the sea.
 - The Brahmins, of India, believe Heaven to be a 'milky ocean' (foam of the sea) which

54

THE CELTS

- is why they believe the cow to be sacred.
 - All of the Supergods; Krishna, Tutankhamun, Buddha, Chi'in Shi Huangdi, Jesus, Viracocha (and Viracocha Pachacamac) and Lord Pacal performed miracles.
 - When they died they all became Venus.
- 16 The Indian Vedas (divine knowledge of the Brahmins) tell of the Indian holy trinity; Brahma (the holy ghost, or spirit), Vishnu (the flesh, incarnate on Earth) and Siva (the father). Vishnu is said to have incarnated on Earth nine times, the eighth time as the Hindu God Lord Krishna and the ninth as Lord Buddha. The Vedas are believed to have been written by the Indo-Aryans prior to their entering India in around 1500 BC. The four main Vedas are: the Rig-Veda (hymns and praises); Yajur-Veda (prayers and sacrificial formulae); Sama-Veda (tunes and chants); and Atharva-Veda of the Atharvans, the officiating priests at the sacrifices. They are all written in an old form of ancient Sanskrit.
 - 17 Stories from the sun shield of Monte Alban (plates 2, 3, and 7 to 11) show Lord Pacal reincarnating as Venus.
 - 18 The 'bright' star refers to the bright star in the dark night sky (the evening star) as against the 'morning star' that competed with the rising sunlight and hence was less bright.
 - 19 The plural for 'fibula', used to describe a safety-pin style cloak fastener.
 - 20 When found the carriage was crushed, requiring extensive restoration and reconstruction.
 - 21 The formative period in pre-history during which bronze was most favoured for metalworking.
 - 22 Previously featured in *The Lost Tomb of Viracocha and The Terracotta Warriors*.
 - 23 The technique is often compared to the later technique of Cloisonné, the ornamental craft technique in which metal strips are soldered into a pattern on a metal surface and the resulting compartments (cloisons) filled with coloured enamel and then fired.
 - 24 *Encyclopaedia of World Mythology*, Octopus, 1975.
 - 25 *Encyclopaedia of Myths and Legends*, Arthur Cotterell, Cassell, 1989.
 - 26 Governed Britain between AD 78-85.
 - 27 In *Natural History*, published in around AD 50, the Roman scholar Pliny the Elder (AD 23-79) describes the pagan oak tree ritual '...clad in white robes, the priest climbs a tree and with a golden sickle cuts a sprig of mistletoe'. *Pharsalia*, [c. 48 BC], Loeb, 1962.
 - 28 The Universal Law of action and reaction.
 - 29 The National Museum of Ireland has dozens of examples like these.

of the fifth does not appear in the translation because of damage to the original manuscript). Éber was born in Egypt, Donn was born in Scythia and Ír and Éremon, the youngest two, were born in Spain.

- 10 The Annals state that the 'Scotti' were converted to the Christian faith [in AD 433]. *The Encyclopaedia of Ireland* [under the heading of 'Scotland, links with'] says that later 'an expedition led by the three sons of Erc from Irish Dal Rada (in County Antrim, Ireland) founded the Kingdom of Argyll (now Scotland) in around AD 500'. Hence the origin of Ir-land (after Ir the son of Mil) and Scotland (after Scotta, the Pharaoh's daughter).
- 11 So named after Hall, the Celtic word for salt, and statt the Celtic word for place.
- 12 *The Tutankhamun Prophecies* sets out in detail just how the 28-day solar radiation cycle correlates with variations in fertility hormones.
- 13 Paleomagnetic evidence, from Pearson and Cox (*Climate and Evolution*, 1978) and tree ring data from Bucha, 1970 [both documented in *The Mayan Prophecies*] suggest that the Sun's magnetic field shifted in 3113 BC and again in around AD 620 (1,366,040 days after the 3113 BC shift). It appears that the magnetic twist of AD 620 was of insufficient strength to tilt any of the planets off their axis but did result in adverse radiation from the Sun that deleteriously affected the Earth (see main text).
- 14 Areas around the Earth's Equator are struck by more perpendicular solar X-rays and are hence more affected.
- 15
 - They were all born through an Immaculate Conception.
 - Buddha's mother's name was Maya. Maya was also the name of the architect of Tutankhamun's tomb and also the name of his wet-nurse. The word Maya means 'illusion' in ancient Sanskrit.
 - Maya was a culture that flourished in Mexico c. 100-750 AD and Lord Pacal, the priest-king leader of the Maya, taught that this life was illusion.
 - Krishna is the Greek word for the 'anointed one' and Christ anointed (baptised) others.
 - Jesus is known as the Son of God [from the Tibetan Chi (godly energy) and the Greek Zeus, the creator God, Chi Zeus, the Son of God who died c. 32 BC. [*The Bible* says; '...the angel of the Lord appeared unto Joseph in a dream saying ... M a r y shall bring forth a son and his name shall be Chi Zeus', Matthew I, 20-21]; The name Tut-ankh-amun translates into 'the living image of God'—the Son of God—and Ch'in Shi Huangdi, the first Emperor of unified China, was known to his people as the 'Son of Heaven'.
 - Stories left behind by Lord Pacal (from the Mural of Bonampak) say that he was the Lord of Sacrifice who died on a cross made from two pieces of wood. Jesus died on the cross at Easter and the Roman Catholic word for Easter is Pashcal.
 - Viracocha is the Quechua word for 'foam of the sea', a metaphor for the perfect human being. A person in 'the foam of the sea' is simultaneously in contact with all of the Earth's elements of earth, air, fire and water; the earth, beneath the feet, the air, the fire (the Sun) that shines on the face, and the water. Any movement towards the sea causes loss of contact with the earth. Any movement towards the land causes loss of contact with the water. Hence, a person reaches perfection only in the 'foam of the sea'. A 60cm- (2-foot-) high golden anthropomorphic figure of a crab-man (plate 5d) was found in the tomb of Viracocha at Sipan in Peru. The crab is a creature that lives on the land and in the sea, in the foam of the sea.
 - The Brahmans, of India, believe Heaven to be a 'milky ocean' (foam of the sea) which

CHAPTER TWO

Who Wrote the Bible?

The Old Testament

As the early Celts migrated westwards from the Taklamakan Desert, tribal settlements were developing in the fertile valleys of the Nile and on the Sumerian plains between the rivers Tigris and Euphrates between today's Iraq and Iran, and in Canaan [today's Israel].

Abraham, the founding father in Jewish history, was born in around 1900 BC in Ur, Sumeria (figure 25). The Bible says that God told Abraham to lead the Hebrew tribes out of Sumer to escape the famine of the times. Together they followed the Euphrates upstream and crossed the desert to Egypt. At first the Egyptians tolerated their presence but in the years that followed they succumbed to slavery in a land where the natives worshipped a variety of gods.

Beliefs competed for supremacy in regard to which system best explained how the world was created, what forces controlled nature, which prayers and practises offered the best protection against malevolent forces and what might be the best ways to maximise prosperity. In time, tribes grouped together for protection as well as for economies of scale that accommodated efficient planting and harvesting of crops, food storage and transportation.

Unification of Egypt began under the reign of King Narmer in around 3000 BC—the first of a line of pharaohs that continued through thirty dynasties until 525 BC. With unification the diversity of gods became structured leading to a hierarchy in polytheistic belief. The many gods, though, now reported to a principal god Atum, or Ra,

Sumerian Civilization



Figure 25. Mesopotamia lies between the rivers Tigris and Euphrates in present-day Iraq. The civilizations of Sumer, c. 3500 BC, and Babylon, c. 609 BC, flourished here.

the Sun God who created the Earth and the heavens. He controlled the lesser gods who in turn managed the elements on Earth, the air, earth and water. He also controlled the sky god Osiris, the god of resurrection and afterlife who lived in the constellation of Orion. It was from here that the notion of body and soul emerged with the belief that this earthly existence merely sustained the body for a short time and could be followed by a heavenly extension that sustained the soul—for millions and millions of years; pure souls would be reborn in the stars and impure ones returned to Earth for another attempt at spiritual purification. This new concept of 'reincarnation' called for a disciplined heart, mind and body. At the same time the polytheistic pantheon of gods, under the control (for the first time) of a single supreme creator God (Ra), meant that monotheism—one-god worship—had in effect established itself without even a single shot being fired.

CHAPTER TWO

Who Wrote the Bible?

The Old Testament

As the early Celts migrated westwards from the Taklamakan desert, tribal settlements were developing in the fertile valleys of the Nile and on the Sumerian plains between the rivers Tigris and Euphrates between today's Iraq and Iran, and in Canaan [today's Israel].

Abraham, the founding father in Jewish history, was born in around 1900 BC in Ur, Sumeria (figure 25). The Bible says that God told Abraham to lead the Hebrew tribes out of Sumer to escape the famine of the times. Together they followed the Euphrates upstream and crossed the desert to Egypt. At first the Egyptians tolerated their presence but in the years that followed they succumbed to slavery in a land where the natives worshipped a variety of Gods.

Beliefs competed for supremacy in regard to which system best explained how the World was created, what forces controlled nature, which prayers and practises offered the best protection against malevolent forces and what might be the best ways to maximise prosperity. In time, tribes grouped together for protection as well as for economies of scale that accommodated efficient planting and harvesting of crops, food storage and transportation.

Unification of Egypt began under the reign of King Narmer in around 3000 BC—the first of a line of Pharaoh's that continued through 30 dynasties until 525 BC. With unification the diversity of gods became struc-

Sumerian Civilization

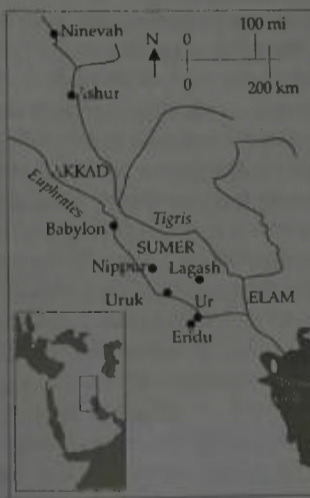

Figure 25. Mesopotamia lies between the Rivers Tigris and Euphrates in present day Iraq. The civilizations of Sumer c. 3500 BC, and Babylon, c. 609 BC, flourished there.

tured leading to a hierarchy in polytheistic belief. The many gods though, now, reported to a principal god Atum, or Ra, the Sun God who created the Earth and the heavens. He controlled the lesser gods who in turn managed the elements on Earth, the air, earth and water. He also controlled the sky god Osiris, the God of Resurrection and the Afterlife, who lived in the constellation of Orion. It was from here that the notion of body and soul emerged with the belief that this earthly existence merely sustained the body for a short time and could be followed by a heavenly extension that sustained the soul—for millions and millions of years; pure souls would be reborn in the stars and impure ones returned to Earth for another attempt at spiritual purification. This new concept of 'reincarnation' called for a disciplined heart, mind and body. At the same time the polytheistic pantheon of gods, under the control (for the first time) of a single supreme creator God (Ra) meant that monotheism—one-god worship—had in effect established itself without even a single

As sun worship blossomed Egyptian civilization rose to new heights with a miraculous flowering in intellectual ability. Mighty pyramids, emulating the rays of the Sun from the sky to the Earth, arose as though by magic from master masons with a knowledge that could only have been acquired from the gods—or a Supergod—who must have walked among them. The timely appearance of hieroglyphic writing enabled the expression of the new beliefs in praise of God the great architect of the Universe. The new holy pyramids became the place for prayer and for the texts of prayer of which more than 800 have been found carved in columns inside pyramids between 2375 and 2055 BC. Those in the pyramid of Pepi I, just south of Unas at Saqqara, were the first to be discovered, although those of Unas themselves date from the earliest written (2375–2345 BC). Nine pyramids belonging to six kings buried at Saqqara (who reigned between the sixth and eighth dynasties) and three pyramids of Pepi II together contain the entire collection of pyramid texts. Some were intended to protect the deceased from harm in the afterlife; others made offerings and appealed to Osiris on behalf of the deceased to propitiate resurrection. Some were read to the deceased to ease the way into the underworld or to Ra in the afterlife.

More than 1,000 'spells' have been found inscribed on coffins made between 2055 and 1795 BC. It was essential to set down the hopes and desires of the deceased along with prayers, chants and incantations inside the coffin, to preclude any misunderstanding with the gods in regard to the final resting place of the soul. Inscriptions in the pyramid of Unas document the myth of Osiris and take the story one stage further: '... Oh King, you are the companion of Orion... may you traverse the nearby Milky Way... and may you go to the place where Osiris is'. This was intended to escort the dead king to the constellation of Orion to become a star. The pyramid at Unas near Giza contains some of the most remarkable inscriptions, including the wisdom of Ptah-Hotep text. The circular zodiac on the ceiling of the temple at Dendera shows the constellations of the stars depicted by animals, exemplifying a sophisticated knowledge of astronomy and astrology. But the peace, prosperity and tranquillity were not to last.

As Egypt grew larger it beseeched and sustained an administrative bureaucracy to control and delegate power and authority. Civil servants who at first served the interests of the Pharaoh increasingly

shot being fired.

As sun worship blossomed Egyptian civilization rose to new heights with a miraculous flowering in intellectual ability. Mighty pyramids, emulating the rays of the Sun from the sky to the Earth, arose as though by magic from master masons with a knowledge that could only have been acquired from the gods—or a Supergod—who must have walked among them. The timely appearance of hieroglyphic writing enabled the expression of the new beliefs in praise of God the great architect of the Universe. The new holy pyramids became the place for prayer and for the texts of prayer of which more than 800 have been found carved in columns inside pyramids between 2375 and 2055 BC. Those in the pyramid of Pepi I, just south of Unas at Saqqara, were the first to be discovered, although those of Unas themselves date from the earliest written (2375–2345 BC). Nine pyramids belonging to six kings buried at Saqqara (who reigned between the sixth and eighth dynasties) and three pyramids of Pepi II, together contain the entire collection of pyramid texts. Some were intended to protect the deceased from harm in the afterlife; others made offerings and appealed to Osiris on behalf of the deceased to propitiate resurrection. Some were read to the deceased to ease the way into the underworld or to Ra in the afterlife.

More than 1,000 'spells' have been found inscribed on coffins made between 2055 and 1795 BC. It was essential to set down the hopes and desires of the deceased along with prayers, chants and incantations inside the coffin, to preclude any misunderstanding with the gods in regard to the final resting place of the soul. Inscriptions in the pyramid of Unas document the myth of Osiris and take the story one stage further: '... Oh King, you are the companion of Orion... may you traverse the nearby Milky Way... and may you go to the place where Osiris is'. This was intended to escort the dead king to the constellation of Orion to become a star. The pyramid at Unas near Giza contains some of the most remarkable inscriptions, including the wisdom of Ptah-Hotep text. The circular zodiac on the ceiling of the temple at Dendera shows the constellations of the stars depicted by animals, exemplifying a sophisticated knowledge of astronomy and astrology. But the peace, prosperity and tranquillity were not to last.

As Egypt grew larger it beseeched and sustained an administrative

began to serve their own—levying their own taxes, proclaiming their offices to be hereditary and ultimately styling themselves as princes to succeed the throne, which they did during the eleventh and twelfth dynasties.

Around 1680 BC central authority broke down and control was lost. Egypt was invaded by the Hyksos ('rulers of foreign land'), the bold, swift and agile invaders from the East who swept through the country with horses and chariots to seize the throne of Egypt and the land of Canaan—to Mesopotamia—inspiring trade and culture with people on the Tigris and Euphrates. But their tenure was short-lived; within 100 years the Hyksos were in turn displaced by Kanes, a local dynast from Upper Egypt, who drove them out, restoring power to the pharaohs. Thus began the 'New Kingdom' of Egypt.

By 1323 BC the Supergod sun king Tutankhamun 'the living image of God' had been and gone. His brief reign was over by the age of nineteen. Treasures in his tomb, discovered in 1922 in the Valley of the Kings by the archaeologist Howard Carter, reveal that he was known to his people as the feathered snake, which he carried on his forehead, meaning that he, like Lord Pacal, understood and taught the super-science of the Sun and the higher orders of spirituality.

A name carved on the wall of his tomb says that the architect of his tomb was called Maya. Like Lord Pacal he took to the throne at the age of 9. His tomb was marked by door seals containing groups of 9 so-called prisoners (figure A16) bound by ropes that terminate with the lotus blossom, the symbol of sun worship—because it opens its petals in the morning, follows the Sun across the sky and closes them again at sunset. The scene in the cartouche was a complex metaphor used to convey three messages: firstly, that this earthly existence amounts to divine bondage—the place where individuals are imprisoned and controlled by the effects of the Sun. By referring to captive prisoners the scene, at the same time, denounced the killing of prisoners, effectively espousing the notion of 'thou shall not kill'. And, finally, the collection of seals endowed the door of Tutankhamun's tomb with the number of a Supergod, 99999. To ensure that the numerological significance of this did not go unnoticed, he was entombed in 9 levels of coffin.

The number of those destined for Heaven was cleverly concealed within the bandages of his mummy which contained 143 treasures,

bureaucracy to control and delegate power and authority. Civil servants who at first served the interests of the Pharaoh increasingly began to serve their own—levying their own taxes, proclaiming their offices to be hereditary and ultimately styling themselves as princes to succeed the throne, which they did during the eleventh and twelfth dynasties.

Around 1680 BC central authority broke down and control was lost. Egypt was invaded by the Hyksos ('rulers of foreign land') the bold, swift and agile invaders from the East who swept through the country with horses and chariots to seize the throne of Egypt and the land of Canaan—to Mesopotamia—inspiring trade and culture with people around the Rivers Tigris and Euphrates. But their tenure was short-lived, within a hundred years the Hyksos were in turn displaced by Kanes, a local dynast from Upper Egypt, who drove them out restoring power to the pharaohs. Thus began the 'New Kingdom' of Egypt.

By 1323 BC the Supergod sun king Tutankhamun 'the living image of God' had been and gone. His brief reign was over by the age of 19. Treasures in his tomb, discovered in 1922 in the Valley of the Kings by the archaeologist Howard Carter, reveal that he was known to his people as the feathered-snake, which he carried on his forehead; meaning that he, like Lord Pacal, understood and taught the super-science of the Sun and the higher orders of spirituality.

A name carved on the wall of his tomb says that the architect of his tomb was called Maya. Like Lord Pacal he took to the throne at the age of 9. His tomb was marked by door seals containing groups of 9 so-called prisoners (figure A16) bound by ropes that terminate with the lotus blossom, the symbol of sun worship—because it opens its petals in the morning, follows the Sun across the sky and closes them again at sunset. The scene in the cartouche was a complex metaphor used to convey three messages; firstly, that this earthly existence amounts to divine bondage—the place where individuals are imprisoned and controlled by the effects of the Sun. By referring to captive prisoners the scene, at the same time, denounced the killing of prisoners, effectively espousing the notion of 'thou shall not kill'. And, finally, the collection of seals endowed the door of Tutankhamun's tomb with the number of a Supergod, 99999. To ensure that the numerological significance of this did not go unnoticed he was entombed in 9 levels of coffin.

making his body the 144th treasure in the bundle. The super-science of the Sun was well represented by all of the solar astronomical constants which appear over and over again, in his jewellery and in the architecture of his tomb—proving beyond doubt that he taught the super-science of the Sun. And, as we have already heard, a painting on the wall of his tomb shows him as twins, aged around nineteen, embracing Osiris in the sky, implying that, like Lord Pacal and Jesus, Tutankhamun when he died became Venus.

His mother and father are thought to have been Queen Nefertiti and Akhenaten, the son of Amenophis III (who reigned from 1391 to 1351 BC)—but decoded treasures from Tutankhamun's tomb also reveal that Akhenaten could not have been his biological father because his treasures reveal that Tutankhamun was conceived, like Jesus, through an Immaculate Conception.³¹

No one knows what happened to Nefertiti, who was almost always portrayed wearing clothes adorned with the Sun and its rays. But a passage in Revelation may have something to say:

And there appeared a great wonder in Heaven; a woman clothed in the Sun and the moon under her feet . . . and she brought forth a man child who was to rule all nations with a rod of iron, and her child was caught up unto God and to his throne. And the woman fled into the wilderness, where she has a place prepared of God. (Revelation XII, 1-6)

Howard Carter believed that tomb robbers had stolen a heavy iron measuring rod from Tutankhamun's tomb. But analysis of the treasures suggests that the rod had been deliberately omitted to convey the message that 'Tutankhamun ruled with a rod of iron'—a divine rod that could be magnetised and used as a compass, allowing him to lead his people to the 'Promised Land'. This explains why he carried the crook and flail; the crook carried by the shepherd is associated with spiritual leadership—to provide spiritual nourishment, food for the soul. The flail, used to thresh corn, provides food for the body.

His mother Nefertiti is portrayed in a famous sculpture by the potter Thutmose with her left eye [the symbol of the moon] missing, associating her with the moon (perhaps under her feet). And the painting in Tutankhamun's tomb shows him being raised up to Heaven.

The number of those destined for Heaven was cleverly concealed within the bandages of his mummy which contained 143 treasures, making his body the 144th treasure in the bundle. The super-science of the Sun was well represented by all of the solar astronomical constants which appear over and over again, in his jewellery and in the architecture of his tomb—proving beyond doubt that he taught the super-science of the Sun. And, as we have already heard, a painting on the wall of his tomb shows him as twins, aged around 19, embracing Osiris in the sky; inferring that, like Lord Pacal and Jesus, Tutankhamun when he died became Venus.

His mother and father are thought to have been Queen Nefertiti and Akhenaten, the son of Amenophis III (who reigned from 1391 to 1351 BC)—but decoded treasures from Tutankhamun's tomb also reveal that Akhenaten could not have been his biological father because his treasures reveal that Tutankhamun was conceived, like Jesus, through an Immaculate Conception³¹.

No one knows what happened to Nefertiti who was almost always portrayed wearing clothes adorned with the Sun and its rays. But a passage in Revelation may have something to say:

And there appeared a great wonder in Heaven; a woman clothed in the Sun and the moon under her feet . . . and she brought forth a man child who was to rule all nations with a rod of iron, and her child was caught up unto God and to his throne. And the woman fled into the wilderness, where she has a place prepared of God (Revelation XII, 1-6).

Howard Carter believed that tomb robbers had stolen a heavy iron measuring rod from Tutankhamun's tomb. But analysis of the treasures suggests that the rod had been deliberately omitted to convey the message that 'Tutankhamun ruled with a rod of iron'—a divine rod that could be magnetised and used as a compass, allowing him to lead his people to the Promised Land. This explains why he carried the crook and flail; the crook carried by the shepherd is associated with spiritual leadership—to provide spiritual nourishment, food for the soul. The flail, used to thresh corn, provides food for the body.

His mother Nefertiti is portrayed in a famous sculpture by the potter

Those unfamiliar with *The Tutankhamun Prophecies* will be unaware of the true life and times of the great king. The discovery of his tomb in 1922 gave way to a frenzied media circus that swept the Western world. The breathtaking beauty, style and sophistication of his treasures at first inspired awe in all who beheld them but then raced on to fuel a new art form—*Art Deco*—that struggled and hopelessly failed to live up to the quality and genius of the Tutankhamun prototypes that were made by a miracle.

Akhenaten's unfinished tomb, to the east of Amarna, never received his body. The psychoanalyst Dr. Karl Abraham, a precursor to Sigmund Freud, proposed that Akhenaten, who reigned from 1353 to 1335 BC, was actually Moses of the Jewish faith (*Imago*, I, 1912, pp. 346-7). Freud, for his part, believed that Akhenaten's reign in Amarna came to an end when he was deposed and exiled to Sinai but later returned in an attempt to seize power from Rameses I. Failing in this he persuaded a band of Hebrew slaves to follow him into the desert to start a new religion based solely on monotheistic sun worship, without any regard for subordinate gods.

The official account says that Moses was a Hebrew judge and a lawgiver who led the Israelites out of Egypt to the promised land of Canaan.

After wandering in the desert for forty years, he led them south along the coast of the Gulf of Suez (plate 15) to Mount Sinai where he received the oral and written law, including the Ten Commandments engraved on two stone tablets from Jehovah [God]. He then went on to compile the first five books of the Jewish holy book, the Torah. The commandments from God were these: have no other God but Jehovah; make no idols; do not take the Lord's name in vain; remember the Sabbath and keep it holy; honour thy mother and father; do not kill; do not commit adultery; do not steal; do not bear false witness [do not lie], and do not covet the possessions of others. Thus was laid the foundation for Jewish history upon which all else followed and from which all Jewish law and custom is based.

Moses then built the most sacred treasure of the Israelites, a throne for God, the Ark of the Covenant, and carried it with him on his travels north along the Gulf of Aqaba into the wilderness where once again his tribes experienced hunger, thirst and hardship for several more years.

Thutmose with her left eye [the symbol of the moon] missing, associating her with the moon (perhaps under her feet). And the painting in Tutankhamun's tomb shows him being raised up to Heaven.

Those unfamiliar with *The Tutankhamun Prophecies* will be unaware of the true life and times of the great king. The discovery of his tomb in 1922 gave way to a frenzied media circus that swept the western world. The breathtaking beauty, style and sophistication of his treasures at first inspired awe in all who beheld them but then raced on to fuel a new art form—*Art-Deco*—that struggled and hopelessly failed to live up to the quality and genius of the Tutankhamun prototypes that were made by a miracle.

Akhenaten's unfinished tomb, to the east of Amarna, never received his body. The psychoanalyst Dr Karl Abraham, a pre-cursor to Sigmund Freud, proposed that Akhenaten, who reigned from 1353 to 1335 BC, was actually Moses of the Jewish faith (*Imago*, I, 1912, pp. 346-7). Freud, for his part, believed that Akhenaten's reign in Amarna came to an end when he was deposed and exiled to Sinai but later returned in an attempt to seize power from Rameses I. Failing in this he persuaded a band of Hebrew slaves to follow him into the desert to start a new religion based solely on monotheistic sun worship, without any regard for subordinate gods.

The official account says that Moses was a Hebrew judge and a lawgiver who led the Israelites out of Egypt to the promised land of Canaan.

After wandering in the desert for 40 years he led them south along the coast of the Gulf of Suez (plate 15) to Mount Sinai where he received the oral and written law, including the Ten Commandments engraved on two stone tablets from Jehova [God]. He then went on to compile the first five books of the Jewish holy book the Torah. The commandments from God were these: have no other God but Jehova; make no idols; do not take the Lord's name in vain; remember the Sabbath and keep it holy; honour thy mother and father; do not to kill; do not to commit adultery; do not steal; do not bear false witness [do not lie] and do not covet the possessions of others. Thus was laid the foundation for Jewish history upon which all else followed and from which all Jewish law and custom is based.

Moses then built the most sacred treasure of the Israelites, a throne for

Moses at last gazed upon the Promised Land but died before settling there. His successor Joshua took up the mantle leading the Israelites into Canaan in around 1200 BC.

Saul, the first king of Israel, was wounded in a battle with the Philistines from the north and later committed suicide. He was succeeded by King David (1060-970 BC) who took the Ark to Jerusalem and made it the capital. In both Jewish and Christian belief the Messiah would be a direct descendant of David.

Although 'the five books of Moses' date back to his era, scholars agree that he could not have written them all, given that his own death is described in the last chapter. They more likely developed as the works of many scholars based on ancient traditions and stories told during their exodus in the wilderness:

And the Lord Said unto Moses; write this for a memorial in a book, and rehearse it in the ears of Joshua. (*Exodus XVII, 14*)

Comprehensive accounts of wars were written during the reign of King David together with the names and deeds of his followers. The story of the Ark and the life of Saul fill the two books of Samuel. He also probably compiled the Psalms of David.

Once a year the twelve tribes of Israel met before the Ark at its resting place on Mount Zion in the centre of Jerusalem to confirm their allegiance to God and to follow the divine edicts.³² The Judge—the president, priest and lawmaker of the day—who administered the Mosaic Law and interpreted the Holy Scriptures as they developed, maintained social order. The first biblical scriptures were thus in existence during the 'time of the Judges'; the seventh book of the Bible, *Judges*, sets down their genealogies (*Judges X, 1-5; XII, 7-15*), their achievements and the legal code. The Ten Commandments found their way into *Exodus (XX, 1-17)*.

During David's reign Israel was at its peak, socially, politically and militaristically, until his son Absalom organised a rebellion and marched on the capital. David crushed him and his supporters but fearful of future rebellions was slow to relinquish the throne to another son, until 963 BC when he chose Solomon to succeed him.

Solomon, who was known for his wisdom, wrote more than 3,000 proverbs that together form the body of the book of *Proverbs*, the

twentieth book of the Bible. His scribes chronicled his times, in the books of Samuel I and II, and a version of Creation that was set down on record to compete with one from the times of David.

Solomon, like his father, was a Freemason. David's emblem, the six-pointed Star of David, the symbol of Judaism, consists of two equilateral triangles. The upright pyramid-shaped triangle contains the angles of 60°, 60°, 60° (666) (figure 9). These numbers in the inverted triangle of the star become 999. Meaning that David and Solomon understood the higher orders of spirituality; they understood that the purpose of this earthly existence was to purify the soul inside the body [666] and thereby convert it into a higher-voltage soul [999] fit for Heaven.

The black and white chequered pattern on the floor of the temple was adopted by the board game of checkers (or 'draughts') to likewise carry the knowledge forward. The black and white represent the opposing forces of good and evil, and the nights and days of reincarnation; the squares, virtue and knowledge. Each player was given twelve discs, representing the twelve haloes of the Disciples, to help journey across the board where they must negotiate, in turn, each night and day [each incarnation], snake-like, across the board of sixty-four squares (2⁶) [good and bad raised to the power of 6]. The player who reaches the far side of the board wins the earthly battle after snaking the least and taking most prisoners (killing the least) to become a double-decker disc, the twin star (planet) Venus in the heavens, which now, unconstrained and unfettered in the physical world, has the power to move both forwards and backwards on the board, ghost-like.

The book of *Ecclesiastes* in the Bible is attributed to Solomon because it begins with: 'The words of the preacher, the son of David, King in Jerusalem'. It is also the book most revered by esoteric orders containing much wisdom and mystery, lamenting in great detail on how all of man's activities in the physical world are a complete waste of time: 'Vanity of vanities, all is vanity' (*Ecclesiastes XII, 8*). Other observations include:

- That which is crooked cannot be made straight and that which is wanting cannot be numbered.
- In much wisdom there is much grief.
- He that increases knowledge increases sorrow.

God, the Ark of the Covenant and carried it with him on his travels north along the Gulf of Aqaba into the wilderness where once again his tribes experienced hunger, thirst and hardship for several more years. Moses at last, gazed upon the Promised Land but died before settling there. His successor Joshua took up the mantle leading the Israelites into Canaan in around 1200 BC.

Saul, the first king of Israel, was wounded in a battle with the Philistines from the north and later committed suicide. He was succeeded by King David (1060-970 BC) who took the Ark to Jerusalem and made it the Capital. In both Jewish and Christian belief the Messiah would be a direct descendant of David.

Although 'the five books of Moses' date back to his era, scholars agree that he could not have written them all, given that his own death is described in the last Chapter. They more likely developed as the works of many scholars based on ancient traditions and stories told during their exodus in the wilderness:

And the Lord Said unto Moses; write this for a memorial in a book, and rehearse it in the ears of Joshua (*Exodus XVII, 14*).

Comprehensive accounts of wars were written during the reign of King David together with the names and deeds of his followers. The story of the Ark and the life of Saul fill the two books of *Samuel*. He also probably compiled the Psalms of David.

Once a year the twelve tribes of Israel³² met before the Ark at its resting place on Mount Zion in the centre of Jerusalem to confirm their allegiance to God and to follow the divine edicts. The Judge—the president, priest and lawmaker of the day—who administered the Mosaic Law and interpreted the Holy Scriptures as they developed, maintained social order. The first biblical scriptures were thus in existence during the 'time of the Judges'; the seventh book of the Bible, *Judges*, sets down their genealogies (*Judges X, 1-5; XII, 7-15*) their achievements and the legal code. The Ten Commandments found their way into *Exodus (XX, 1-17)*.

During David's reign Israel was at its peak, socially, politically and militaristically until his son Absalom organised a rebellion and marched on the capital. David crushed him and his supporters but fearful of future rebellions was slow to relinquish the throne to another son, until 963 BC

when he chose Solomon to succeed him.

Solomon, who was known for his wisdom, wrote more than 3,000 proverbs that together form the body of the book of *Proverbs*, the twentieth book of the Bible. His scribes chronicled his times, in the books of Samuel I and II, and a version of Creation that was set down on record to compete with one from the times of David.

Solomon, like his father, was a Freemason. David's emblem, the six-pointed Star of David, the symbol of Judaism, consists of two equilateral triangles. The upright pyramid-shaped triangle contains the angles of 60°, 60°, 60° (666) (figure 9). These numbers in the inverted triangle of the star become 999. Meaning that David and Solomon understood the higher orders of spirituality; they understood that the purpose of this earthly existence was to purify the soul inside the body [666] and thereby convert it into a higher voltage soul [999] fit for Heaven.

The black and white chequered pattern on the floor of the temple was adopted by the board game of 'checkers' (or 'draughts') to likewise carry the knowledge forward. The black and white represent the opposing forces of good and evil, and the nights and days of reincarnation; the squares virtue and knowledge. Each player was given 12 discs, representing the 12 haloes of the Disciples, to help journey across the board where they must negotiate, in turn, each night and day [each incarnation], snake-like, across the board of 64 squares (2⁶) [good and bad raised to the power of 6]. The winner who reaches the far side of the board wins the earthly battle after snaking the least and taking most prisoners (killing the least) to become a double-decker disc, the twin star (planet) Venus in the heavens, which now, unconstrained and unfettered in the physical world has the power to move both forwards and backwards on the board, ghost-like.

The book of *Ecclesiastes* in the Bible is attributed to Solomon because it begins with: 'The words of the preacher, the son of David, King in Jerusalem'. It is also the book most revered by esoteric orders containing much wisdom and mystery, lamenting in great detail on how all of man's activities in the physical world are a complete waste of time: 'Vanity of vanities, all is vanity' (*Ecclesiastes XII, 8*). Other observations include:

- That which is crooked cannot be made straight and that which is wanting cannot be numbered.

Moses at last gazed upon the Promised Land but died before settling there. His successor Joshua took up the mantle leading the Israelites into Canaan in around 1200 BC.

Saul, the first king of Israel, was wounded in a battle with the Philistines from the north and later committed suicide. He was succeeded by King David (1060-970 BC) who took the Ark to Jerusalem and made it the capital. In both Jewish and Christian belief the Messiah would be a direct descendant of David.

Although 'the five books of Moses' date back to his era, scholars agree that he could not have written them all, given that his own death is described in the last chapter. They more likely developed as the works of many scholars based on ancient traditions and stories told during their exodus in the wilderness:

And the Lord Said unto Moses; write this for a memorial in a book, and rehearse it in the ears of Joshua. (*Exodus XVII, 14*)

Comprehensive accounts of wars were written during the reign of King David together with the names and deeds of his followers. The story of the Ark and the life of Saul fill the two books of Samuel. He also probably compiled the Psalms of David.

Once a year the twelve tribes of Israel met before the Ark at its resting place on Mount Zion in the centre of Jerusalem to confirm their allegiance to God and to follow the divine edicts.³² The Judge—the president, priest and lawmaker of the day—who administered the Mosaic Law and interpreted the Holy Scriptures as they developed, maintained social order. The first biblical scriptures were thus in existence during the 'time of the Judges'; the seventh book of the Bible, *Judges*, sets down their genealogies (*Judges X, 1-5; XII, 7-15*), their achievements and the legal code. The Ten Commandments found their way into *Exodus (XX, 1-17)*.

During David's reign Israel was at its peak, socially, politically and militaristically, until his son Absalom organised a rebellion and marched on the capital. David crushed him and his supporters but fearful of future rebellions was slow to relinquish the throne to another son, until 963 BC when he chose Solomon to succeed him.

Solomon, who was known for his wisdom, wrote more than 3,000 proverbs that together form the body of the book of *Proverbs*, the

God, the Ark of the Covenant and carried it with him on his travels north along the Gulf of Aqaba into the wilderness where once again his tribes experienced hunger, thirst and hardship for several more years. Moses at last, gazed upon the Promised Land but died before settling there. His successor Joshua took up the mantle leading the Israelites into Canaan in around 1200 BC.

Saul, the first king of Israel, was wounded in a battle with the Philistines from the north and later committed suicide. He was succeeded by King David (1060-970 BC) who took the Ark to Jerusalem and made it the Capital. In both Jewish and Christian belief the Messiah would be a direct descendant of David.

Although 'the five books of Moses' date back to his era, scholars agree that he could not have written them all, given that his own death is described in the last Chapter. They more likely developed as the works of many scholars based on ancient traditions and stories told during their exodus in the wilderness;

And the Lord Said unto Moses; write this for a memorial in a book, and rehearse it in the ears of Joshua (*Exodus XVII, 14*).

Comprehensive accounts of wars were written during the reign of King David together with the names and deeds of his followers. The story of the Ark and the life of Saul fill the two books of *Samuel*. He also probably compiled the Psalms of David.

Once a year the twelve tribes of Israel³² met before the Ark at its resting place on Mount Zion in the centre of Jerusalem to confirm their allegiance to God and to follow the divine edicts. The Judge—the president, priest and lawmaker of the day—who administered the Mosaic Law and interpreted the Holy Scriptures as they developed, maintained social order. The first biblical scriptures were thus in existence during the 'time of the Judges'; the seventh book of the Bible, *Judges*, sets down their genealogies (*Judges X, 1-5; XII, 7-15*) their achievements and the legal code. The Ten Commandments found their way into *Exodus (XX, 1-17)*.

During David's reign Israel was at its peak, socially, politically and militaristically until his son Absalom organised a rebellion and marched on the capital. David crushed him and his supporters but fearful of future rebellions was slow to relinquish the throne to another son, until 963 BC

twentieth book of the Bible. His scribes chronicled his times, in the books of *Samuel I and II*, and a version of Creation that was set down on record to compete with one from the times of David.

Solomon, like his father, was a Freemason. David's emblem, the six-pointed Star of David, the symbol of Judaism, consists of two equilateral triangles. The upright pyramid-shaped triangle contains the angles of 60°, 60°, 60° (666) (figure 9). These numbers in the inverted triangle of the star become 999. Meaning that David and Solomon understood the higher orders of spirituality; they understood that the purpose of this earthly existence was to purify the soul inside the body [666] and thereby convert it into a higher-voltage soul [999] fit for Heaven.

The black and white chequered pattern on the floor of the temple was adopted by the board game of checkers (or 'draughts') to likewise carry the knowledge forward. The black and white represent the opposing forces of good and evil, and the nights and days of reincarnation; the squares, virtue and knowledge. Each player was given twelve discs, representing the twelve haloes of the Disciples, to help journey across the board where they must negotiate, in turn, each night and day [each incarnation], snake-like, across the board of sixty-four squares (2⁶) [good and bad raised to the power of 6]. The player who reaches the far side of the board wins the earthly battle after snaking the least and taking most prisoners (killing the least) to become a double-decker disc, the twin star (planet) Venus in the heavens, which now, unconstrained and unfettered in the physical world, has the power to move both forwards and backwards on the board, ghost-like.

The book of *Ecclesiastes* in the Bible is attributed to Solomon because it begins with: 'The words of the preacher, the son of David, King in Jerusalem'. It is also the book most revered by esoteric orders containing much wisdom and mystery, lamenting in great detail on how all of man's activities in the physical world are a complete waste of time: 'Vanity of vanities, all is vanity' (*Ecclesiastes XII, 8*). Other observations include:

- That which is crooked cannot be made straight and that which is wanting cannot be numbered.
- In much wisdom there is much grief.
- He that increases knowledge increases sorrow.

when he chose Solomon to succeed him.

Solomon, who was known for his wisdom, wrote more than 3,000 proverbs that together form the body of the book of *Proverbs*, the twentieth book of the Bible. His scribes chronicled his times, in the books of *Samuel I and II*, and a version of Creation that was set down on record to compete with one from the times of David.

Solomon, like his father, was a Freemason. David's emblem, the 6-pointed Star of David, the symbol of Judaism, consists of two equilateral triangles. The upright pyramid-shaped triangle contains the angles of 60°, 60°, 60° (666) (figure 9). These numbers in the inverted triangle of the star become 999. Meaning that David and Solomon understood the higher orders of spirituality; they understood that the purpose of this earthly existence was to purify the soul inside the body [666] and thereby convert it into a higher voltage soul [999] fit for Heaven.

The black and white chequered pattern on the floor of the temple was adopted by the board game of 'checkers' (or 'draughts') to likewise carry the knowledge forward. The black and white represent the opposing forces of good and evil, and the nights and days of reincarnation; the squares virtue and knowledge. Each player was given 12 discs, representing the 12 haloes of the Disciples, to help journey across the board where they must negotiate, in turn, each night and day [each incarnation], snake-like, across the board of 64 squares (2⁶) [good and bad raised to the power of 6]. The winner who reaches the far side of the board wins the earthly battle after snaking the least and taking most prisoners (killing the least) to become a double-decker disc, the twin star (planet) Venus in the heavens, which now, unconstrained and unfettered in the physical world has the power to move both forwards and backwards on the board, ghost-like.

The book of *Ecclesiastes* in the Bible is attributed to Solomon because it begins with: 'The words of the preacher, the son of David, King in Jerusalem'. It is also the book most revered by esoteric orders containing much wisdom and mystery, lamenting in great detail on how all of man's activities in the physical world are a complete waste of time 'Vanity of vanities, all is vanity' (*Ecclesiastes XII, 8*). Other observations include:

- That which is crooked cannot be made straight and that which is wanting cannot be numbered.

- To every thing there is a season and a time to every purpose under Heaven.
- He that loves silver shall not be satisfied with silver.
- For as the crackling of thorns under the pot, so is the laughter of the fool.
- Anger rests in the bosom of fools.
- He that digs a pit shall fall into it and whoso breaks a hedge a serpent will bite him.
- He that watches the wind will never sow, and he that watches the clouds will never harvest.

Solomon died in 929 BC by which time the land of Israel, drained of funds, was in decline. The country was split into two nations, Israel and Judah, that squabbled for 200 years, allowing the Assyrians to seize the throne of Israel in 745 BC. Judah's demise followed quickly when it fell firstly in 609 BC to the Egyptians and then to the Babylonians. The 200-year period that hosted eighteen kings, the land of the Hebrew, was gone. But all was not lost.

During the troubled times the stories of the Patriarchs, from the time of the Exodus had been committed to parchment. The Song of Lamech (*Genesis IV, 23-24*), the Songs of Miriam (*Exodus 15, 21*), the Well (*Numbers XXI, 17-18*) and Heshbon (*Numbers XXI, 27-29*) had all found their way on to papyrus. The histories of Ahab, Jehu, and Micah (*Kings I and Kings II*) had been chronicled. The stories about Elijah and Elisha had been collated and the Law containing the Ten Commandments had been edited.

The age of the Kings had produced a school of divinely inspired prophets who preached to anyone willing to listen. As Israel spiralled into decline they were succeeded by another group known as the Classic prophets, the 'nevyim', who also preached by word of mouth, whose teachings appeared in books after their death.

The first of the prophetic books to appear was that of Amos who preached goodwill, justice and social responsibility and that monotheism extends to all men in all places. Hosea preached the love of God and that all sins could be forgiven through God's mercy, believing that God was not only wrathful and vengeful but also all loving and forgiving. Lesser prophets like Habakkuk, Zephaniah, Jonah, Obadiah and

- In much wisdom there is much grief
- He that increases knowledge increases sorrow.
- To every thing there is a season and a time to every purpose under Heaven.
- He that loves silver shall not be satisfied with silver.
- For as the crackling of thorns under the pot, so is the laughter of the fool.
- Anger rests in the bosom of fools.
- He that digs a pit shall fall into it and whoso breaks a hedge a serpent will bite him.
- He that watches the wind will never sow, and he that watches the clouds will never harvest.

Solomon died in 929 BC by which time the land of Israel, drained of funds, was in decline. The country was split into two nations, Israel and Judah, that squabbled for 200 hundred years, allowing the Assyrians to seize the throne of Israel in 745 BC. Judah's demise followed quickly when it fell firstly in 609 BC to the Egyptians and then to the Babylonians. The 200-year period that hosted 18 Kings, the land of the Hebrew, was gone. But all was not lost.

During the troubled times the stories of the Patriarchs, from the time of the Exodus had been committed to parchment. The Song of Lamech (*Genesis IV, 23-24*), the Songs of Miriam (*Exodus 15, 21*) the Well (*Numbers XXI, 17-18*) and Heshbon (*Numbers XXI, 27-29*) had all found their way on to papyrus. The histories of Ahab, Jehu, and Micah (*Kings I and Kings II*) had been chronicled. The stories about Elijah and Elisha had been collated and the Law containing the Ten Commandments had been edited.

The age of the Kings had produced a school of divinely inspired prophets who preached to anyone willing to listen. As Israel spiralled into decline they were succeeded by another group known as the Classic prophets, the 'nevyim', who also preached by word of mouth, whose teachings appeared in books after their death.

The first of the prophetic books to appear was that of Amos who preached goodwill, justice and social responsibility and that monotheism extends to all men in all places. Hosea preached the love of God and that all sins could be forgiven through God's mercy, believing that God was not

Micah had their say but failed to inspire intellectual change along the lines of the three great prophets Isaiah, Ezekiel and Jeremiah.

Isaiah, born in Jerusalem in 775 BC, was a doctor and a learned scribe known for his wisdom who preached that divine retribution would snare unrepentant sinners.

Ezekiel preached in Jerusalem during Israeli occupation of the city and warned of the future fall of the nation; when the inevitable happened he could only promise that one day they would have a new home, a new heart and a new spirit.

Jeremiah had foreseen the destruction of Jerusalem and the desecration of Solomon's temple, which actually occurred in 587 BC when Zedekiah—successor to the Babylonian king Nebuchadnezzar—defeated Israel, resulting in the exile of Israel and the captivity of the country by the Babylonians.

In 539 BC the Persian king Cyrus defeated the Babylonians putting an end to Babylonian rule. Jerusalem was in ruins. The prophet Haggai compiled an account of the reconstruction of the temple on Mount Zion. The prophets Zechariah and Malachi chronicled their lives and events of the time.

In 445 BC the prophet Nehemiah was appointed governor of Judah by Cyrus and the smaller neighbouring province of Israel was given the title of Samaria. But, as before, the people of the divided land squabbled.

Nehemiah supervised the physical reconstruction of Jerusalem and kept a detailed account of his own activities. His book, which only appeared 100 years after his death, became the most complete and reliable historical account of the Jews after their captivity.

Under Cyrus the Persians were true liberators of the troubled lands of the Hebrew. Canaan began to be called Palestine 'the land of the Philistines' referring to the lands that 'the Philistines had once tried unsuccessfully to conquer and control' and the Hebrews, previously 'the children of Judah and Israel' came to be known as 'the Jews'.

A new book of Nehemiah was written. More Psalms were added to those that existed and two poems—the Book of Job and the Song of Solomon—were composed. The history of David's reign was set down in Chronicles and the first five books of Moses; Genesis, Exodus, Leviticus, Numbers and Deuteronomy were edited.

only wrathful and vengeful but also all loving and forgiving. Lesser prophets like Habakkuk, Zephaniah, Jonah, Obadiah and Micah had their say but failed to inspire intellectual change along the lines of the three great prophets Isaiah, Ezekiel and Jeremiah.

Isaiah, born in Jerusalem in 775 BC, was a doctor and a learned scribe known for his wisdom who preached that divine retribution would snare unrepentant sinners.

Ezekiel preached in Jerusalem during Israeli occupation of the City and warned of the future fall of the nation; when the inevitable happened he could only promise that one day they would have a new home, a new heart and a new spirit.

Jeremiah had foreseen the destruction of Jerusalem and the desecration of Solomon's temple, which actually occurred in 587 BC when Zedekiah—successor to the Babylonian King Nebuchadnezzar—defeated Israel, resulting in the exile of Israel and the captivity of the country by the Babylonians.

In 539 BC the Persian King Cyrus defeated the Babylonians putting an end to Babylonian rule. Jerusalem was in ruins. The prophet Haggai compiled an account of the reconstruction of the temple on Mount Zion. The prophets Zechariah and Malachi chronicled their lives and events of the time.

In 445 BC the prophet Nehemiah was appointed governor of Judah by Cyrus and the smaller neighbouring province of Israel was given the title of Samaria. But, as before, the people of the divided land squabbled.

Nehemiah supervised the physical reconstruction of Jerusalem and kept a detailed account of his own activities. His book which only appeared a hundred years after his death, became the most complete and reliable historical account of the Jews after their captivity.

Under Cyrus the Persians were true liberators of the troubled lands of the Hebrew. Canaan began to be called Palestine 'the land of the Philistines' referring to the lands that 'the Philistines had once tried unsuccessfully to conquer and control' and the Hebrews, previously 'the children of Judah and Israel' came to be known as 'the Jews'.

A new book of Nehemiah was written. More Psalms were added to those that existed and two poems—the Book of Job and the Song of Solomon—were composed. The history of David's reign was set down in

Ezra, prophet and chief priest at the time, revised and reviewed religious thought and codified Jewish law into the system used today. This enabled non-Hebrew aspirants to understand the spiritual teachings and adopt and convert to the belief if they so chose. The name 'Jew' thus described the people who subscribed to the monotheistic laws of God handed to Moses as set down, clarified and codified by Ezra, rather than to the genetic national bloodline of the Hebrews. Conformance with the Law entitled the adherent to a place in Paradise in the afterlife and was therefore of the utmost importance in the life of the holy. Ezra's codification, set to papyrus scroll, meant that Jews could refer to undisputed holy texts whenever they travelled. By around 330 BC the canon of the Pentateuch was completed and every synagogue now possessed its own copy of the Law, the Jewish Torah.³³

In 338 BC the victory of Philip II over the rest of Greece at Chaeronea (figure 26) was to have repercussions. His son, Alexander the Great, went on to conquer the eastern Mediterranean and in 333 BC defeated the Persian king Darius in Asia Minor, giving the Hebrews new overlords. Alexander marched on to Egypt and in 331 BC established the city of Alexandria. His death, in 323 BC, led to struggles by would-be successors; Seleucids won the area from Antioch, in Syria, and the Greek Ptolemies secured the lands of Egypt for themselves.

Between 283 and 246 BC Alexandria (under the Macedonian king Ptolemy II) sustained a population of around 150,000 Greeks and quickly became the centre of Greek learning and culture throughout the Mediterranean. Learned philosophers, writers, mathematicians and scientists filled the great library where the first translation of the Pentateuch [from Hebrew to Greek] the Septuagint (Latin for 'the seventy') was written—by seventy-two Jewish scholars imprisoned in a monastery under the instructions of the king. The Septuagint now refers to the first Greek translation of the Old Testament that appeared slightly later. Around the same time Esther's history and Daniel's account of the Exodus appeared in Palestine in Hebrew.

In 168 BC the Seleucids swept down from Antioch seizing Palestine from the Ptolemies—declaring that the only God to be worshipped would be the Greek creator god Zeus, to whom they raised an altar at the Temple. In 166 BC the Jews, enraged, rose against the Seleucids and

Route of Alexander the Great

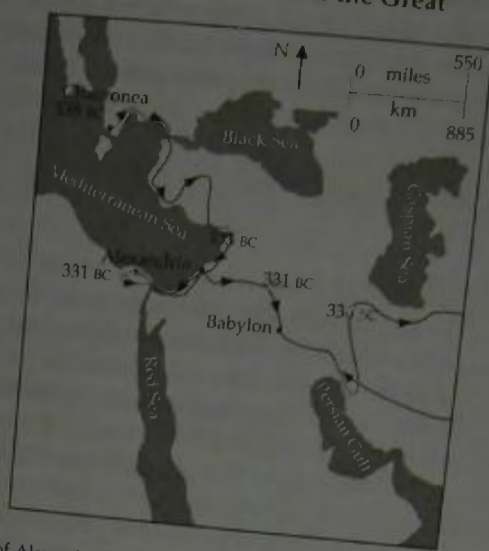

Figure 26. Route of Alexander the Great through Asia Minor to Alexandria in Egypt and beyond to the eastern boundaries of present-day Afghanistan and Pakistan.

within two years ousted Zeus to re-establish their faith. The leader of the rebellion, Judas Maccabaeus, died in 160 BC but fighting continued led by the Maccabean family, or Hasmonaeans (in Hebrew), until the Romans arrived in 63 BC.

The book of Daniel describes the Maccabean revolt, along with two books of Maccabees. The story of *Susanna, Bel and the Dragon, The Prayer of Manasses* and *The Song of the Three Children* were never included in the Protestant version of the Bible but appeared in a second version called the Apocrypha (*secret teachings*), some of which are included in the Roman Catholic version. The Old Testament as we know it today was completed in around AD 90. The two books of the Maccabees, *The Wisdom of Solomon* and *Ecclisasticus*, were included at the time but have since been relegated to the Apocrypha.

The Old Testament was now complete with its seventeen historical books: Genesis, Exodus, Leviticus, Numbers, Deuteronomy, Joshua, Judges, Ruth, the First Book of Samuel, the Second Book of Samuel,

THE CELTIC CHRONICLES

Chronicles and the first five books of Moses; *Genesis, Exodus, Leviticus, Numbers* and *Deuteronomy* were edited.

Ezra, prophet and chief priest at the time, revised and reviewed religious thought and codified Jewish law into the system used today. This enabled non-Hebrew aspirants to understand the spiritual teachings and adopt and convert to the belief if they so chose. The name 'Jew' thus described the people who subscribed to the monotheistic laws of God handed to Moses as set down, clarified and codified by Ezra, rather than to the genetic national bloodline of the Hebrew. Conformance with the Law entitled the adherent to a place in Paradise in the afterlife and was therefore of the utmost importance in the life of the Holy. Ezra's codification, set to papyrus scroll, meant that Jews could refer to undisputed holy texts whenever they travelled. By around 330 BC the Canon³¹ of the Pentateuch was completed and every synagogue now possessed its own copy of the Law. The Jewish *Torah*.

In 338 BC the victory of Philip II over the rest of Greece at Chaeronea (figure 26) was to have repercussions. His son Alexander the Great, went on to conquer the eastern Mediterranean and in 333 BC defeated the Persian king Darius in Asia Minor, giving the Hebrews new overlords. Alexander marched on to Egypt and in 331 BC established the city of Alexandria. His death, in 323 BC, led to struggles by would-be successors; Seleucids won the area from Antioch, in Syria, and the Greek Ptolemies secured the lands of Egypt for themselves.

Between 283 and 246 BC Alexandria (under the Macedonian King Ptolemy II) sustained a population of around 150,000 Greeks and quickly became the centre of Greek learning and culture throughout the Mediterranean. Learned philosophers, writers, mathematicians and scientists filled the great library where the first translation of the Pentateuch [from Hebrew to Greek] the *Septuagint* (Latin for 'the seventy') was written—by seventy-two Jewish scholars imprisoned in a monastery under the instructions of the King. The *Septuagint* now refers to the first Greek translation of *The Old Testament* that appeared slightly later. Around the same time *Esther's history* and *Daniel's account of the Exodus* appeared in Palestine in Hebrew.

In 168 BC the Seleucids swept down from Antioch seizing Palestine from the Ptolemies—declaring that the only God to be worshipped

Route of Alexander the Great

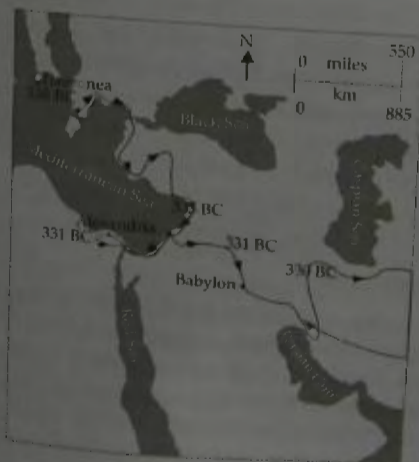

Figure 26. Route of Alexander the Great through Asia Minor to Alexandria in Egypt and beyond to the eastern boundaries of present-day Afghanistan and Pakistan.

would be the Greek creator god Zeus, to whom they raised an altar at the Temple. In 166 BC the Jews, enraged, rose against the Seleucids and within two years ousted Zeus to re-establish their faith. The leader of the rebellion Judas Maccabaeus died in 160 BC but fighting continued led by the Maccabean family, or *Hasmonaeans* (in Hebrew), until the Romans arrived in 63 BC.

The book of *Daniel* describes the Maccabean revolt, along with two books of *Maccabees*. The story of *Susanna, Bel and the Dragon, The Prayer of Manasses* and *The Song of the three Children* were never included in the Protestant version of the Bible but appeared in a second version called the *Apocrypha* (*secret teachings*), some of which are included in the Roman Catholic version. The Old Testament as we know it today was completed in around AD 90. The two books of the *Maccabees, The Wisdom of Solomon* and *Ecclisasticus* were included at the time but have since been relegated to the *Apocrypha*.

the First Book of Kings, the Second Book of Kings, the First Book of Chronicles, the Second Book of Chronicles, Nehemiah and Esther; the five teaching books: Job, Psalms, Proverbs, Ecclesiastes and the Song of Solomon; and the seventeen prophetic books: Isaiah, Jeremiah, The Lamentations of Jeremiah, The Book of the Prophet Ezekiel, The Book of Daniel, Hosea, Joel, Amos, Obadiah, Jonah, Micah, Nahum, Habakkuk, Zephaniah, Haggai, Zechariah and Malachi.

The New Testament

Most of what we know about Jesus comes from the Gospels (Greek for 'proclamations') which his followers Matthew, Mark, Luke and John set down after his death and these appear in the New Testament of the Bible. There are other texts, not quite so celebrated, including thirteen Coptic [early Egyptian Christian] papyrus codices found in a sealed ceramic jar in the desert in 1945 at Nag Hammadi, in Egypt, that include the Gospel of Philip, The Gospel of Thomas, The Acts of Peter, The Gospel of Truth (dating from around AD 150) and The Gospel of Mary Magdalene (c. AD 135).

By AD 63 the Roman Empire extended as far as Palestine, a region of more than 8,000 square miles supporting a population of around a million Jews. They were reluctant bedfellows of the Roman army, who squeezed them to fund their massive projects of roads, bridges, aqueducts and buildings.

About fifty-seven years later, in pursuit of taxes, ruler Caesar Augustus decreed a census be taken of the population to quantify the taxation possibilities, and it was this census that sent the would-be parents of Jesus on a 145-km (90-mile) journey to the town of Bethlehem. His mother Mary was unmarried but engaged to Joseph when she became pregnant through an Immaculate Conception. Visions and dreams persuaded the couple that the child should be born and raised within marriage. The couple agreed to continue into marriage, thereby fulfilling the divine orders of the New Testament and of the Old:

And the angel said unto her, 'fear not Mary, for thou hast found favour with God . . . thou shalt . . . bring forth a son and shall call his name Jesus . . . and the Lord God shall give unto him the throne of his father David'. (Luke 1, 30-32)

THE CELTIC CHRONICLES

The Old Testament was now complete with its seventeen historical books: *Genesis, Exodus, Leviticus, Numbers, Deuteronomy, Joshua, Judges, Ruth, The first book of Samuel, The Second Book of Samuel, The First book of Kings, The Second Book of Kings, The First Book of Chronicles, The Second Book of Chronicles, Nehemiah and Esther*; the five teaching books: *Job, Psalms, Proverbs, Ecclesiastes* and the *Song of Solomon* and the seventeen prophetic books: *Isaiah, Jeremiah, The Lamentations of Jeremiah, The Book of the Prophet Ezekiel, The Book of Daniel, Hosea, Joel, Amos, Obadiah, Jonah, Micah, Nahum, Habakkuk, Zephaniah, Haggai, Zechariah and Malachi*.

The New Testament

Most of what we know about Jesus comes from the Gospels (Greek for 'proclamations') which his followers *Mathew, Mark, Luke and John* set down after his death and these appear in the New Testament of the Bible. There are other texts, not quite so celebrated, including 13 coptic [early Egyptian Christian] papyrus codices found in a sealed ceramic jar in the desert in 1945 at Nag Hamadi, in Egypt, that include the *Gospel of Philip, The Gospel of Thomas, The Acts of Peter, The Gospel of Truth* (dating from around c. AD 150) and *The Gospel of Mary Magdalene* (c. AD 135).

By AD 63 the Roman Empire extended as far as Palestine, a region of more than 8,000 square miles supporting a population of around a million Jews. They were reluctant bedfellows of the Roman army who squeezed them to fund their massive projects of roads, bridges, aqueducts and buildings.

About 57 years later, in pursuit of taxes, ruler Caesar Augustus decreed a census be taken of the population to quantify the taxation possibilities and it was this census that sent the would be parents of Jesus on a 145km (90-mile) journey to the town of Bethlehem. His mother Mary was unmarried but engaged to Joseph when she became pregnant through an Immaculate Conception. Visions and dreams persuaded the couple that the child should be born and raised within marriage. The couple agree to continue into marriage, thereby fulfilling the divine orders of the New Testament and of the Old:

And the angel said unto her, 'fear not Mary, for thou hast found favour with God . . . thou shalt . . . bring forth a son and shall call his name

During the journey Joseph and Mary follow a bright star that leads them to a stable in Bethlehem where Jesus is born (figure 27). Because stepfather Joseph was descended from the line of David, the birth of Jesus, as far as Christians are concerned, fulfils the Old Testament prophecy of Psalms:

The Lord hath sworn in truth unto David; he will not turn from it; of the fruit of thy body will I set upon thy throne. (*Psalms CXXXII, 11*)

Jesus grew up the son of a carpenter, spending the first few months of his life exiled in Egypt, removed from the despot king, Herod. When Herod died the family moved back to Nazareth where Jesus spent his early years. By all accounts he was a remarkable child with a liking for the Jewish scriptures, from the oral traditions that had sustained the Hebrews in the desert to the Laws of Moses and the stories of the patriarchs in the Pentateuch.

His exact movements between the ages of twelve and thirty are little known. Some say he travelled extensively through Tibet, India and Greece. Others say that he visited England with Joseph of Arimathea, a wealthy Pharisee merchant, one of the seventy-one-member Sanhedrin council of Church ministers and possibly a close relative of Jesus. It is Joseph's merchant background that leads some observers to believe that he was a metal merchant who travelled to Cornwall by ship seeking cargoes of tin, lead and copper.

The Englishman William Blake (1757-1827) believed that Jesus did indeed visit Cornwall. The poet, artist and engraver claimed to have had many spiritual experiences including witnessing the appearance of angels and visions of Heaven and Hell. He wrote several prophetic books, among them: *The Marriage of Heaven and Hell*, 1790; *America*, 1793; and *Milton*, 1804. He illustrated editions of the Bible and works of Shakespeare with his own artistic style based on that of Michelangelo and Raphael and he wrote the poem *Jerusalem* in around 1800, speculating that Jesus once walked the land of Cornwall:

And did those feet in ancient times
Walk upon England's mountains green?
And was the Holy Lamb of God,
On England's pleasant pastures seen?

Jesus . . . and the Lord God shall give unto him the throne of his father David'. (Luke 1, 30-32).

During the journey Joseph and Mary follow a bright star (figure 27) that leads them to a stable in Bethlehem where Jesus is born. Because stepfather Joseph was descended from the line of David the birth of Jesus, as far as Christians are concerned, fulfils the Old Testament prophecy of Psalms:

The Lord hath sworn in truth unto David; he will not turn from it; of the fruit of thy body will I set upon thy throne. (*Psalms CXXXII, 11*).

Jesus grew up the son of a carpenter, spending the first few months of his life exiled in Egypt, removed from the despot King Herod. When Herod died the family moved back to Nazareth where Jesus spent his early years. By all accounts he was a remarkable child with a liking for the Jewish scriptures, from the oral traditions that had sustained the Hebrews in the desert to the Laws of Moses and the stories of the patriarchs in the Pentateuch.

His exact movements between the age of 12 and 30 are little known. Some say he travelled extensively through Tibet, India and Greece. Others say that he visited England with Joseph of Aramathea, a wealthy Pharisee merchant, one of the 71-member Sanhedrin Council of Church ministers and possibly a close relative of Jesus. It is Joseph's merchant background that leads some observers to believe that he was a metal merchant who travelled to Cornwall by ship seeking cargoes of tin, lead and copper.

The Englishman William Blake (1757-1827) believed that Jesus did indeed visit Cornwall. The poet, artist and engraver claimed to have had many spiritual experiences including witnessing the appearance of angels and visions of Heaven and Hell. He wrote several prophetic books, among them: *The Marriage of Heaven and Hell*, 1790; *America*, 1793, and *Milton*, 1804. He illustrated editions of the Bible and works of Shakespeare with his own artistic style based on that of Michaelangelo and Raphael and he wrote the poem *Jerusalem* in around 1800, speculating that Jesus once walked the land of Cornwall:



Figure 27. Shrine, from the cathedral at Guadalajara, Mexico, showing the newborn baby Jesus beneath a twin-star, together with Mary and Joseph. Silver spheres, mounted on urns, either side of Jesus represent the various manifestations of the planet Venus as the morning star and the evening star. Joseph and Mary hence introduce Jesus as the twin-star Venus.

And did the Countenance Divine
Shine forth upon our clouded hills?
And was Jerusalem builded here,
Among those dark Satanic mills?

Bring me my bow of burning Gold!
Bring me my arrows of desire!
Bring me my spear! O clouds unfold!
Bring me my Chariot of Fire!

I will not cease from mental fight;
Nor shall my sword sleep in my hand
'Till we have built Jerusalem
In England's green and pleasant land.

Some say that Blake's rendition, put to music in 1916 by Sir Hubert Parry, is, simply, fanciful thinking. After all, verse two questions whether Jerusalem could have been built among the dark satanic mills of England—that did not appear until the age of water-power during the Industrial Revolution, in around the 1830s—a long time after the age of Jesus.

Others maintain that although Blake's account may be romanticised, evidence does exist to substantiate the story. Researcher Sean Thomas, a Cornishman, cites the popularity of 'safron cakes' in Cornwall, pointing out that the spice saffron is a native of Southeast Asia and plentiful in the Middle East.³⁴ Another ancient Cornish dish, 'date and lemon' pie, must have likewise been made from imported ingredients from the Middle East where the dates grow. He also notes similarities in Cornish place-names with those in the Middle East: the village of Joppa might be named after the Phoenician port of Joppa; the ancient town opposite St. Michael's Mount known as Marazion could be derived from Mara Zion or 'Zion across the sea', suggesting an early Zionist connection, as could the Cornish-named towns of Jericho and Bojewyan and places named Market Jew Street and Joseph's Lane in the tin-mining village of Redruth. Smelting houses in those days were known as 'Jews Houses' and the word *sarazin* (perhaps from Saracen) was used to describe tin slag. There is even a Cornish hymn that begins with the line 'Joseph was a finner'.

In the port of Padstow, in North Cornwall, there is a well called



Figure 27. Shrine, from the cathedral at Guadalajara, Mexico, showing the newborn baby Jesus beneath a bright star, together with Mary and Joseph. Silver spheres, mounted on urns, either side of Jesus represent the various manifestations of the planet Venus as the morning star and the evening star. Joseph and Mary hence introduce Jesus as the twin-star Venus.

And did those feet in ancient times
Walk upon England's mountains green?
And was the Holy Lamb of God,
On England's pleasant pastures seen?
And did the Countenance Divine
Shine forth upon our clouded hills?
And was Jerusalem builded here,
Among those dark Satanic mills?

Bring me my bow of burning Gold!
Bring me my arrows of desire!
Bring me my spear! O clouds unfold!
Bring me my Chariot of Fire!

I will not cease from mental fight;
Nor shall my sword sleep in my hand
'Till we have built Jerusalem
In England's green and pleasant land.

Some say that Blake's rendition, put to music in 1916 by Sir Hubert Parry is, simply, fanciful thinking. After all, verse two questions whether Jerusalem could have been built among the dark satanic mills of England—that did not appear until the age of Water-power during the Industrial Revolution, in around the 1830s—a long time after the age of Jesus.

Others maintain that although Blake's account may be romanticised, evidence does exist to substantiate the story. Researcher Sean Thomas, a Cornishman, cites³⁴ the popularity of 'safron cakes' in Cornwall, pointing out that the spice Saffron is a native of Southeast Asia and plentiful in the Middle East. Another ancient Cornish dish 'date and lemon' pie must have likewise been made from imported ingredients from the Middle East where the dates grow. He also notes similarities in Cornish place names with those in the Middle East: the village of Joppa might be named after the Phoenician Port of Joppa; the ancient town opposite St Michael's Mount known as Marazion could be derived from Mara Zion or 'Zion across the sea' suggesting an early Zionist connection, as could the Cornish named towns of Jericho, Bojewyan and places named Market Jew

Jesus, as the Twin-star Venus



Figure 27. Shrine, from the cathedral at Guadalajara, Mexico, showing the newborn baby Jesus beneath a twin-star, together with Mary and Joseph. Silver spheres, mounted on urns, either side of Jesus represent the various manifestations of the planet Venus as the morning star and the evening star. Joseph and Mary hence introduce Jesus as the twin-star Venus.

68

*And did the Countenance Divine
Shine forth upon our clouded hills?
And was Jerusalem builded here,
Among those dark Satanic mills?*

*Bring me my bow of burning Gold!
Bring me my arrows of desire!
Bring me my spear! O clouds unfold!
Bring me my Chariot of Fire!*

*I will not cease from mental fight;
Nor shall my sword sleep in my hand
'Till we have built Jerusalem
In England's green and pleasant land.*

Some say that Blake's rendition, put to music in 1916 by Sir Hubert Parry, is, simply, fanciful thinking. After all, verse two questions whether Jerusalem could have been built among the dark satanic mills of England—that did not appear until the age of water-power during the Industrial Revolution, in around the 1830s—a long time after the age of Jesus.

Others maintain that although Blake's account may be romanticised, evidence does exist to substantiate the story. Researcher Sean Thomas, a Cornishman, cites the popularity of 'safron cakes' in Cornwall, pointing out that the spice saffron is a native of Southeast Asia and plentiful in the Middle East.³⁴ Another ancient Cornish dish, 'date and lemon' pie, must have likewise been made from imported ingredients from the Middle East where the dates grow. He also notes similarities in Cornish place-names with those in the Middle East: the village of Joppa might be named after the Phoenician port of Joppa; the ancient town opposite St. Michael's Mount known as Marazion could be derived from Mara Zion or 'Zion across the sea', suggesting an early Zionist connection, as could the Cornish-named towns of Jericho and Bojewyan and places named Market Jew Street and Joseph's Lane in the tin-mining village of Redruth. Smelting houses in those days were known as 'Jews Houses' and the word *sarazin* (perhaps from Saracen) was used to describe tin slag. There is even a Cornish hymn that begins with the line 'Joseph was a tinner'.

In the port of Padstow, in North Cornwall, there is a well called

69

Jesus, as the Twin-Star Venus



Figure 27. Shrine, from the cathedral at Guadalajara, Mexico, showing the newborn baby Jesus beneath a bright star, together with Mary and Joseph. Silver spheres, mounted on urns, either side of Jesus represent the various manifestations of the planet Venus as the morning star and the evening star. Joseph and Mary hence introduce Jesus as the twin-star Venus.

70

*And did those feet in ancient times
Walk upon England's mountains green?
And was the Holy Lamb of God,
On England's pleasant pastures seen?
And did the Countenance Divine
Shine forth upon our clouded hills?
And was Jerusalem builded here,
Among those dark Satanic mills?*

*Bring me my bow of burning Gold!
Bring me my arrows of desire!
Bring me my spear! O clouds unfold!
Bring me my Chariot of Fire!*

*I will not cease from mental fight;
Nor shall my sword sleep in my hand
'Till we have built Jerusalem
In England's green and pleasant land.*

Some say that Blake's rendition, put to music in 1916 by Sir Hubert Parry is, simply, fanciful thinking. After all, verse two questions whether Jerusalem could have been built among the dark satanic mills of England—that did not appear until the age of Water-power during the Industrial Revolution, in around the 1830s—a long time after the age of Jesus.

Others maintain that although Blake's account may be romanticised, evidence does exist to substantiate the story. Researcher Sean Thomas, a Cornishman, cites³⁴ the popularity of 'safron cakes' in Cornwall, pointing out that the spice Saffron is a native of Southeast Asia and plentiful in the Middle East. Another ancient Cornish dish 'date and lemon' pie must have likewise been made from imported ingredients from the Middle East where the dates grow. He also notes similarities in Cornish place names with those in the Middle East; the village of Joppa might be named after the Phoenician Port of Joppa; the ancient town opposite St Michael's Mount known as Marazion could be derived from Mara Zion or 'Zion across the sea' suggesting an early Zionist connection, as could the Cornish named towns of Jericho, Bojewyan and places named Market Jew

71

'Jesus's Well', from where Joseph and Jesus could have sailed north to Somerset and onwards up the River Brue to the silver- and lead-bearing Mendip Hills near Glastonbury. Silver mines at Charterhouse above the Roman settlement of Aquae Sulis (Bath) are known to have been in operation by at least AD 49.

Jesus's life as a teacher, as opposed to that of a novice, seems to have begun after meeting with his forerunner John the Baptist at the age of thirty. He had twelve Disciples, followers who with discipline absorbed the holy teachings and who would later go forward to spread the word as Apostles (teachers).

The names of the Apostles listed in the New Testament Gospels of Mark (III, 14-19), Luke (VI, 12-16) and Matthew (X, 2-4) are these:

The Original Twelve Apostles—according to Mark (III, 13-19):

- Simon [he surnamed Peter]
- James the son of Zebedee
- John the brother of James
- Andrew
- Philip
- Bartholomew
- Matthew
- Thomas
- James the son of Alphaeus
- Thaddaeus
- Simon the Canaanite
- Judas Iscariot

According to Luke (VI, 13-16):

- Simon (whom he also named Peter)
- Andrew (Simon's brother)
- James
- John
- Philip
- Bartholomew
- Matthew
- Thomas
- James the son of Alphaeus
- Simon called Zelotes

Street and Joseph's Lane in the tin mining village of Redruth. Smelting houses in those days were known as 'Jews Houses' and the word sarazin (perhaps from Saracen) was used to describe tin slag. There is even a Cornish hymn that begins with the line 'Joseph was a tinner'.

In the port of Padstow, in North Cornwall, there is a Well called 'Jesus's Well', from where Joseph and Jesus could have sailed north to Somerset and onwards up the River Brue to the silver and lead-bearing Mendip Hills near Glastonbury. Silver mines at Charterhouse above the Roman settlement of Aquae Sulis (Bath) are known to have been in operation by at least AD 49.

Jesus's life as a teacher, as opposed to that of a novice, seems to have begun after meeting with his forerunner John the Baptist at the age of 30. He had 12 Disciples, followers who with discipline absorbed the holy teachings, who would later go forward to spread the word as Apostles (teachers).

The names of the Apostles listed in the New Testament Gospels of Mark (III, 14-19), Luke (VI, 12-16) and Mathew (X, 2-4) are these:

The Original Twelve Apostles—according to Mark (III, 13-19):

- Simon [he surnamed Peter]
- James the son of Zebedee
- John the brother of James
- Andrew
- Philip
- Bartholomew
- Matthew
- Thomas
- James the son of Alphaeus
- Thaddaeus
- Simon the Canaanite
- Judas Iscariot

According to Luke (VI, 13-16):

- Simon (whom he also named Peter)
- Andrew (Simon's brother)
- James

- Judas the brother of James
- Judas Iscariot

According to Matthew (X, 2-4):

- Simon, who is called Peter
- James the son of Zebedee
- John [James's brother]
- Andrew [Simon Peter's brother]
- Philip
- Bartholomew
- Thomas
- Matthew the publican (a tax collector called 'Levi' by Mark)
- James the son of Alphaeus
- Lebaeus whose surname was Thaddaeus [Jude Thaddeus]
- Simon the Canaanite
- Judas Iscariot

According to Luke he began his ministry around the age of thirty. Quickly acquiring his group of Disciples, he set off for Galilee, establishing a new ministry at Capernaum, a small Jewish lakeside town with a population of some 5,000 located between Damascus and Alexandria. He taught the Laws of Moses and the Ten Commandments and began to make his mark as an unusual teacher. The people were astonished at his teaching because he taught them as one who had authority and not in the manner of scribes.

Jesus added another commandment to those handed down to Moses; 'Love thy neighbour as I have loved you'. (John XIII, 34)

This 'love' Jesus spoke of was not the sentimental love of *affectionados* drawn together by desire. Yes, he was aware of how the physical senses stimulate hormonal production in the mind and body and how those chemicals can drag the mind, heart and soul into the world of illusion and 'hormone induced insanity' that many people call 'love'. But he was also mindful of the General Theory of Existence and the Theories of Divine Reconciliation and Iterative Spiritual Development (figures A18, A19 and A20) that demand a continuous supply of babies that only insanity can accommodate. Nor was it the love between two brothers willing to die for each other. It was more than both of these.

- John
- Philip
- Bartholomew
- Matthew
- Thomas
- James the son of Alphaeus
- Simon called Zelotes
- Judas the brother of James
- Judas Iscariot

According to Mathew (X, 2-4):

- Simon, who is called Peter
- James the son of Zebedee
- John [James's brother]
- Andrew [Simon Peter's brother]
- Philip
- Bartholomew
- Thomas
- Matthew the publican (a tax collector called 'Levi' by Mark)
- James the son of Alphaeus
- Lebaeus whose surname was Thaddaeus [Jude Thaddeus]
- Simon the Canaanite
- Judas Iscariot

According to Luke he began his ministry around the age of 30. Quickly acquiring his group of Disciples he set off for Galilee, establishing a new ministry at Capernaum, a small Jewish lakeside town with a population of some 5,000 located between Damsascus and Alexandria. He taught the Laws of Moses and the Ten Commandments and began to make his mark as an unusual teacher. The people were astonished at his teaching because he taught them as one who had authority and not in the manner of scribes.

Jesus added another commandment to those handed down to Moses; 'Love thy neighbour as I have loved you' (John XIII, 34).

This 'love' Jesus spoke of was not the sentimental love of *affectionados*

'Jesus's Well', from where Joseph and Jesus could have sailed north to Somerset and onwards up the River Brue to the silver- and lead-bearing Mendip Hills near Glastonbury. Silver mines at Charterhouse above the Roman settlement of Aquae Sulis (Bath) are known to have been in operation by at least AD 49.

Jesus's life as a teacher, as opposed to that of a novice, seems to have begun after meeting with his forerunner John the Baptist at the age of thirty. He had twelve Disciples, followers who with discipline absorbed the holy teachings and who would later go forward to spread the word as Apostles (teachers).

The names of the Apostles listed in the New Testament Gospels of Mark (III, 14-19), Luke (VI, 12-16) and Matthew (X, 2-4) are these:

The Original Twelve Apostles—according to Mark (III, 13-19):

- Simon [he surnamed Peter]
- James the son of Zebedee
- John the brother of James
- Andrew
- Philip
- Bartholomew
- Matthew
- Thomas
- James the son of Alphaeus
- Thaddaeus
- Simon the Canaanite
- Judas Iscariot

According to Luke (VI, 13-16):

- Simon (whom he also named Peter)
- Andrew (Simon's brother)
- James
- John
- Philip
- Bartholomew
- Matthew
- Thomas
- James the son of Alphaeus
- Simon called Zelotes

- Judas the brother of James
- Judas Iscariot

According to Matthew (X, 2-4):

- Simon, who is called Peter
- James the son of Zebedee
- John [James's brother]
- Andrew [Simon Peter's brother]
- Philip
- Bartholomew
- Thomas
- Matthew the publican (a tax collector called 'Levi' by Mark)
- James the son of Alphaeus
- Lebaeus whose surname was Thaddaeus [Jude Thaddeus]
- Simon the Canaanite
- Judas Iscariot

According to Luke he began his ministry around the age of thirty. Quickly acquiring his group of Disciples, he set off for Galilee, establishing a new ministry at Capernaum, a small Jewish lakeside town with a population of some 5,000 located between Damascus and Alexandria. He taught the Laws of Moses and the Ten Commandments and began to make his mark as an unusual teacher. The people were astonished at his teaching because he taught them as one who had authority and not in the manner of scribes.

Jesus added another commandment to those handed down to Moses; 'Love thy neighbour as I have loved you'. (John XIII, 34)

This 'love' Jesus spoke of was not the sentimental love of affectionates drawn together by desire. Yes, he was aware of how the physical senses stimulate hormonal production in the mind and body and how those chemicals can drag the mind, heart and soul into the world of illusion and 'hormone induced insanity' that many people call 'love'. But he was also mindful of the General Theory of Existence and the Theories of Divine Reconciliation and Iterative Spiritual Development (figures A18, A19 and A20) that demand a continuous supply of babies that only insanity can accommodate. Nor was it the love between two brothers willing to die for each other. It was more than both of these.

Street and Joseph's Lane in the tin mining village of Redruth. Smelting houses in those days were known as 'Jews Houses' and the word sarazin (perhaps from Saracen) was used to describe tin slag. There is even a Cornish hymn that begins with the line 'Joseph was a tinner'.

In the port of Padstow, in North Cornwall, there is a Well called 'Jesus's Well', from where Joseph and Jesus could have sailed north to Somerset and onwards up the River Brue to the silver and lead-bearing Mendip Hills near Glastonbury. Silver mines at Charterhouse above the Roman settlement of Aquae Sulis (Bath) are known to have been in operation by at least AD 49.

Jesus's life as a teacher, as opposed to that of a novice, seems to have begun after meeting with his forerunner John the Baptist at the age of 30. He had 12 Disciples, followers who with discipline absorbed the holy teachings, who would later go forward to spread the word as Apostles (teachers).

The names of the Apostles listed in the New Testament Gospels of Mark (III, 14-19), Luke (VI, 12-16) and Mathew (X, 2-4) are these:

The Original Twelve Apostles—according to Mark (III, 13-19):

- Simon [he surnamed Peter]
- James the son of Zebedee
- John the brother of James
- Andrew
- Philip
- Bartholomew
- Matthew
- Thomas
- James the son of Alphaeus
- Thaddaeus
- Simon the Canaanite
- Judas Iscariot

According to Luke (VI, 13-16):

- Simon (whom he also named Peter)
- Andrew (Simon's brother)
- James

- John
- Philip
- Bartholomew
- Matthew
- Thomas
- James the son of Alphaeus
- Simon called Zelotes
- Judas the brother of James
- Judas Iscariot

According to Mathew (X, 2-4):

- Simon, who is called Peter
- James the son of Zebedee
- John [James's brother]
- Andrew [Simon Peter's brother]
- Philip
- Bartholomew
- Thomas
- Matthew the publican (a tax collector called 'Levi' by Mark)
- James the son of Alphaeus
- Lebaeus whose surname was Thaddaeus [Jude Thaddeus]
- Simon the Canaanite
- Judas Iscariot

According to Luke he began his ministry around the age of 30. Quickly acquiring his group of Disciples he set off for Galilee, establishing a new ministry at Capernaum, a small Jewish lakeside town with a population of some 5,000 located between Damascus and Alexandria. He taught the Laws of Moses and the Ten Commandments and began to make his mark as an unusual teacher. The people were astonished at his teaching because he taught them as one who had authority and not in the manner of scribes.

Jesus added another commandment to those handed down to Moses; 'Love thy neighbour as I have loved you'. (John XIII, 34)

This 'love' Jesus spoke of was not the sentimental love of affectionates



The love of which he spoke referred to an unconditional *sincere and genuine wish for the spiritual, physical, intellectual and emotional well-being of another living thing*. A love that could survive ingratitude, evil conduct and repudiation of God. A love spontaneously tendered to those who had done nothing to deserve it, to all those who had any spark of goodness. 'And who has not?' asked Jesus, saying that his Father wanted no one to perish.

His perception envisaged one God, the Father unseen but all seeing, ever watchful over the actions of his children, mindful of both thought and deed. No other religion had brought the Father so intimately close to his children with equanimity for all, the good the bad and the thankless.

The belief that a final day of judgement would take place, at which the condition of the departing soul would be determined according to past actions in this life, is perhaps the most salutary for Christians. The path to salvation was a spiritual one requiring little ceremony, no payments and no daily orders. Sins would be forgiven and forgiveness would alleviate the soul from the burden of guilt, allowing purification through inward truth. Sincerity in thought was more important than acts of charity.

Jesus taught in parables, stories that had meaning on two levels, literal and figurative. Generally they formed allegories which impressed a picture in the mind, which as we have seen was also the preferred method of teaching by Lord Pacal.

The purpose of the parable was to persuade the listener to consider deeply the underlying issues and so inspire change. In Matthew XIII, 3-23, Jesus points out how different people react to hearing the word of God: 'Some of the sower's seed fell on the footpath and were eaten by birds. Some fell on rocky ground and perished on the hot earth. Some fell on good ground and thrived to produce gain of a hundred fold', the message being that those who hear and understand the word of God yield astounding results. Twenty-nine parables of Jesus appear in the Gospels of Matthew, Mark, Luke and John.

Rabbi Moses Maimonides, the great Jewish theologian, comments: Every time you find in our book a tale, the reality of which is repugnant to both reason and common sense, then be sure that the tale contains a profound allegory veiling a deeply mysterious

drawn together by desire. Yes, he was aware of how the physical senses stimulate hormonal production in the mind and body and how those chemicals can drag the mind, heart and soul into the world of illusion and 'hormone induced insanity' that many people call 'love'. But he was also mindful of the General Theory of Existence and the Theories of Divine Reconciliation and Iterative Spiritual Development (figures A18, A19 and A20) that demand a continuous supply of babies that only insanity can accommodate. Nor was it the love between two brothers willing to die for each other. It was more than both of these.

The love of which he spoke referred to an unconditional *sincere and genuine wish for the spiritual, physical, intellectual and emotional well-being of another living thing*. A love that could survive ingratitude, evil conduct and repudiation of God. A love spontaneously tendered to those who had done nothing to deserve it, to all those who had any spark of goodness. 'And who has not?' asked Jesus, saying that his Father wanted no one to perish.

His perception envisaged one God, the Father unseen but all seeing, ever watchful over the actions of his children, mindful of both thought and deed. No other religion had brought the Father so intimately close to his children with equanimity for all, the good the bad and the thankless.

The belief that a final day of judgement would take place, at which the condition of the departing soul would be determined according to past actions in this life, is perhaps the most salutary for Christians. The path to salvation was a spiritual one requiring little ceremony, no payments and no daily orders. Sins would be forgiven and forgiveness would alleviate the soul from the burden of guilt, allowing purification through inward truth. Sincerity in thought was more important than acts of charity.

Jesus taught in parables, stories that had meaning on two levels, literal and figurative. Generally they formed allegories which impressed a picture in the mind, which as we have seen was also the preferred method of teaching by Lord Pacal.

The purpose of the parable was to persuade the listener to consider deeply the underlying issues and so inspire change. In Matthew XIII, 3-23, Jesus points out how different people react to hearing the word of

truth; and the greater the absurdity of the letter, the deeper the wisdom of spirit. (*Hidden Wisdom in the Holy Bible*, vol. 1, G. Hodson, Wheaton, Ill., Theosophical Publishing House)

The Parable of the Sower has more to say. It implies that God's teachings inculcate knowledge and wisdom in the individual and in so doing engender talent that produces good works. The inference here is that no man is cleverer than the next. And yet, paradoxically, it is clear that some men do have better ideas than others.

God is light and light enters the mind through the eye. Every eye is a different combination of colours, which means that every eye is tuned to receive light of a different frequency. The eye converts light into electrical signals that travel along the optic nerves to the brain that detects the light signals. Eyes tuned to the God frequency thus receive and process ideas from God.

This is to say that voltage alone, brought forward from a previous incarnation, is insufficient to boost intellectual processing and the acquisition of wisdom and virtuous growth in soul voltage during the current incarnation; to hear the message of God individuals need to have a pure heart and be tuned in to the God frequency. Good ideas come from God. Bad ideas come from the body.

Christ openly states that some knowledge is purposely concealed: 'He that has ears to hear let him hear'. (*Revelation II, 7, 11, 29, III, 6, 13, 22, XIII, 9*) To his Disciples he says:

Unto you it is given to know the mysteries of God: but to others in parables; that seeing they might not see, and hearing they might not understand. (*Luke VIII, 8-10*)

The reasons for the secrecy become apparent with the discourse: Give not that which is holy unto the dogs, neither cast ye your pearls before swine, lest they trample them under foot and turn again to rend you. (*Matthew IX, 6*)

Author Roland Peterson says:

Certain knowledge can be destructive in the hands of those who are morally unprepared—destructive to self and others. (*Everyone Is Right*, Roland Peterson, De Vorss & Co., 1986)

God: 'Some of the sower's seed fell on the footpath and were eaten by birds. Some fell on rocky ground and perished on the hot earth. Some fell on good ground and thrived to produce gain of a hundred fold', the message being that those who hear and understand the word of God yield astounding results. Twenty-nine Parables of Jesus appear in the Gospels of *Mathew, Mark, Luke and John*.

Rabbi Moses Maimonides, the great Jewish theologian comments: Every time you find in our book a tale, the reality of which is repugnant to both reason and common sense, then be sure that the tale contains a profound allegory veiling a deeply mysterious truth; and the greater the absurdity of the letter, the deeper the wisdom of spirit (*Hidden Wisdom in the Holy Bible*, vol.1, G. Hodson, Wheaton Ill, Theosophical Publishing House).

The Parable of the Sower has more to say. It implies that God's teachings inculcate knowledge and wisdom in the individual and in so doing engender talent that produces good works. The inference here is that no man is cleverer than the next. And yet, paradoxically, it is clear that some men do have better ideas than others?

God is light and light enters the mind through the eye. Every eye is a different combination of colours, which means that every eye is tuned to receive light of a different frequency. The eye converts light into electrical signals that travel along the optic nerves to the brain that detects the light signals. Eyes tuned to the God frequency thus receive and process ideas from God.

This is to say that voltage alone, brought forward from a previous incarnation, is insufficient to boost intellectual processing and the acquisition of wisdom and virtuous growth in soul voltage during the current incarnation; to hear the message of God individuals need to have a pure heart and be tuned in to the God frequency. Good ideas come from God. Bad Ideas come from the body.

Christ openly states that some knowledge is purposely concealed: 'He that has ears to hear let him hear'. (*Revelation II, 7, 11, 29, III, 6, 13, 22, XIII, 9*). To his Disciples he says:

Unto you it is given to know the mysteries of God: but to others in parables; that seeing they might not see, and hearing they might not

The love of which he spoke referred to an unconditional sincere and genuine wish for the spiritual, physical, intellectual and emotional well-being of another living thing. A love that could survive ingratitude, evil conduct and repudiation of God. A love spontaneously tendered to those who had done nothing to deserve it, to all those who had any spark of goodness. 'And who has not?' asked Jesus, saying that his Father wanted no one to perish.

His perception envisaged one God, the Father unseen but all seeing, ever watchful over the actions of his children, mindful of both thought and deed. No other religion had brought the Father so intimately close to his children with equanimity for all, the good the bad and the thankless.

The belief that a final day of judgement would take place, at which the condition of the departing soul would be determined according to past actions in this life, is perhaps the most salutary for Christians. The path to salvation was a spiritual one requiring little ceremony, no payments and no daily orders. Sins would be forgiven and forgiveness would alleviate the soul from the burden of guilt, allowing purification through inward truth. Sincerity in thought was more important than acts of charity.

Jesus taught in parables, stories that had meaning on two levels, literal and figurative. Generally they formed allegories which impressed a picture in the mind, which as we have seen was also the preferred method of teaching by Lord Pacal.

The purpose of the parable was to persuade the listener to consider deeply the underlying issues and so inspire change. In Matthew XIII, 3-23, Jesus points out how different people react to hearing the word of God: 'Some of the sower's seed fell on the footpath and were eaten by birds. Some fell on rocky ground and perished on the hot earth. Some fell on good ground and thrived to produce gain of a hundred fold', the message being that those who hear and understand the word of God yield astounding results. Twenty-nine parables of Jesus appear in the Gospels of Matthew, Mark, Luke and John.

Rabbi Moses Maimonides, the great Jewish theologian, comments:

Every time you find in our book a tale, the reality of which is repugnant to both reason and common sense, then be sure that the tale contains a profound allegory veiling a deeply mysterious

truth; and the greater the absurdity of the letter, the deeper the wisdom of spirit. (*Hidden Wisdom in the Holy Bible*, vol. 1, G. Hodson, Wheaton, Ill., Theosophical Publishing House)

The Parable of the Sower has more to say. It implies that God's teachings inculcate knowledge and wisdom in the individual and in so doing engender talent that produces good works. The inference here is that no man is cleverer than the next. And yet, paradoxically, it is clear that some men do have better ideas than others.

God is light and light enters the mind through the eye. Every eye is a different combination of colours, which means that every eye is tuned to receive light of a different frequency. The eye converts light into electrical signals that travel along the optic nerves to the brain that detects the light signals. Eyes tuned to the God frequency thus receive and process ideas from God.

This is to say that voltage alone, brought forward from a previous incarnation, is insufficient to boost intellectual processing and the acquisition of wisdom and virtuous growth in soul voltage during the current incarnation; to hear the message of God, individuals need to have a pure heart and be tuned in to the God frequency. Good ideas come from God. Bad ideas come from the body.

Christ openly states that some knowledge is purposely concealed: 'he that has ears to hear let him hear'. (*Revelation II, 7, 11, 29, III, 6, 13, 22, XIII, 9*) To his Disciples he says:

Unto you it is given to know the mysteries of God: but to others in parables; that seeing they might not see, and hearing they might not understand. (*Luke VIII, 8-10*)

The reasons for the secrecy become apparent with the discourse:

Give not that which is holy unto the dogs, neither cast ye your pearls before swine, lest they trample them under foot and turn again to rend you. (*Matthew IX, 6*)

Author Roland Peterson says:

Certain knowledge can be destructive in the hands of those who are morally unprepared—destructive to self and others. (*Everyone is Right*, Roland Peterson, De Vorss & Co., 1986)

drawn together by desire. Yes, he was aware of how the physical senses stimulate hormonal production in the mind and body and how those chemicals can drag the mind, heart and soul into the world of illusion and 'hormone induced insanity' that many people call 'love'. But he was also mindful of the General Theory of Existence and the Theories of Divine Reconciliation and Iterative Spiritual Development (figures A18, A19 and A20) that demand a continuous supply of babies that only insanity can accommodate. Nor was it the love between two brothers willing to die for each other. It was more than both of these.

The love of which he spoke referred to an unconditional sincere and genuine wish for the spiritual, physical, intellectual and emotional well being of another living thing. A love that could survive ingratitude, evil conduct and repudiation of God. A love spontaneously tendered to those who had done nothing to deserve it, to all those who had any spark of goodness. 'And who has not?' asked Jesus, saying that his Father wanted no one to perish.

His perception envisaged one God, the Father unseen but all seeing, ever watchful over the actions of his children, mindful of both thought and deed. No other religion had brought the Father so intimately close to his children with equanimity for all, the good the bad and the thankless.

The belief that a final day of judgement would take place, at which the condition of the departing soul would be determined according to past actions in this life, is perhaps the most salutary for Christians. The path to salvation was a spiritual one requiring little ceremony, no payments and no daily orders. Sins would be forgiven and forgiveness would alleviate the soul from the burden of guilt, allowing purification through inward truth. Sincerity in thought was more important than acts of charity.

Jesus taught in parables, stories that had meaning on two levels, literal and figurative. Generally they formed allegories which impressed a picture in the mind, which as we have seen was also the preferred method of teaching by Lord Pacal.

The purpose of the parable was to persuade the listener to consider deeply the underlying issues and so inspire change. In Matthew, XIII, 3-23, Jesus points out how different people react to hearing the word of

God; 'Some of the sower's seed fell on the footpath and were eaten by birds. Some fell on rocky ground and perished on the hot earth. Some fell on good ground and thrived to produce gain of a hundred fold', the message being that those who hear and understand the word of God yield astounding results. Twenty-nine Parables of Jesus appear in the Gospels of *Mathew, Mark, Luke and John*.

Rabbi Moses Maimonides, the great Jewish theologian comments:

Every time you find in our book a tale, the reality of which is repugnant to both reason and common sense, then be sure that the tale contains a profound allegory veiling a deeply mysterious truth; and the greater the absurdity of the letter, the deeper the wisdom of spirit (*Hidden Wisdom in the Holy Bible*, vol.1, G. Hodson, Wheaton Ill, Theosophical Publishing House).

The Parable of the Sower has more to say. It implies that God's teachings inculcate knowledge and wisdom in the individual and in so doing engender talent that produces good works. The inference here is that no man is cleverer than the next. And yet, paradoxically, it is clear that some men do have better ideas than others?

God is light and light enters the mind through the eye. Every eye is a different combination of colours, which means that every eye is tuned to receive light of a different frequency. The eye converts light into electrical signals that travel along the optic nerves to the brain that detects the light signals. Eyes tuned to the God frequency thus receive and process ideas from God.

This is to say that voltage alone, brought forward from a previous incarnation, is insufficient to boost intellectual processing and the acquisition of wisdom and virtuous growth in soul voltage during the current incarnation; to hear the message of God individuals need to have a pure heart and be tuned-in to the God frequency. Good ideas come from God. Bad ideas come from the body.

Christ openly states that some knowledge is purposely concealed: 'he that has ears to hear let him hear' (*Revelation II, 7, 11, 29, III, 6, 13, 22, XIII, 9*). To his Disciples he says:

Unto you it is given to know the mysteries of God: but to others in parables; that seeing they might not see, and hearing they might not

The Popol Vuh, the holy book of the Maya, begins with the words:

The Popol Vuh cannot be seen any more... the original book written long ago existed, but its sight is hidden from the searcher and the thinker. (*The Popol Vuh*, Delia Goetz and Sylvanus G. Morley, University of Oklahoma Press, 1947, p. 79)

Another passage from the same book says:

We are going away [to die], we have completed our mission here. Then Balam-Quitze left the symbol of his being. "This is a resemblance which I leave for you, this shall be your power"... He left the symbol whose form was invisible because it was *wrapped-up* and could not be unwrapped: the seam did not show because it was not seen when they wrapped it up. (*The Popol Vuh*, Delia Goetz and Sylvanus G. Morley, University of Oklahoma Press, 1947, p. 79) [author's italics]

Meaning that Lord Pacal chose to conceal his holy knowledge 'wrapped-up' in Maya transformers. Hidden from the archaeologist and the grave robber. Hidden from the searcher and thinker.

But it was another gift from Jesus that caused his fame to spread; he could heal the sick with his bare hands, or simply with his will. Like the other Supergods, Jesus worked miracles; thirty-four ascribed to him are set down in the Gospels. He appeared to overcome physical laws to achieve super-human results for his efforts and, in addition, to have a deep insight into the foundations of physical nature and the influence of mind over matter that was not of this world.

As the fame of Jesus and his teachings spread he became known as the 'King of the Jews' among followers. The Jewish clergy objected, insisting that he did not conform to their perception of a Messiah. After all, he was the son of a poor carpenter, born in a stable, who did not have the credentials to call himself King. How, they questioned, could this man Jesus say he was the Son of God? As far as the Jews were concerned, this was blasphemy.

For their part the Romans had no axe to grind on the subject of Jesus or religion; they were more concerned with maintaining law and order and with it the uninterrupted flow of taxes. But Jesus's adversaries conspired to entrap him and the Sanhedrin found him guilty of

THE CELTIC CHRONICLES

understand (*Luke VIII, 8-10*).

The reasons for the secrecy become apparent with the discourse;

Give not that which is holy unto the dogs, neither cast ye your pearls before swine, lest they trample them under foot and turn again to rend you (*Matthew IX, 6*).

Author Roland Peterson says:

Certain knowledge can be destructive in the hands of those who are morally unprepared—destructive to self and others (*Everyone is Right*, Roland Peterson, De Vorss & Co., 1986).

The Popol Vuh, the Holy book of the Maya begins with the words;

The Popol Vuh Cannot be seen any more...the original book written long ago existed, but its sight is hidden from the searcher and the thinker (*The Popol Vuh*, Delia Goetz and Sylvanus G. Morley, University of Oklahoma Press, 1947, p.79).

Another passage from the same book says;

We are going away [to die], we have completed our mission here. Then Balam-Quitze left the symbol of his being. "This is a resemblance which I leave for you, this shall be your power"...He left the symbol whose form was invisible because it was *wrapped-up* and could not be unwrapped: the seam did not show because it was not seen when they wrapped it up (*The Popol Vuh*, Delia Goetz and Sylvanus G. Morley, University of Oklahoma Press, 1947, p.79). [Author's Italics].

Meaning that Lord Pacal chose to conceal his holy knowledge 'wrapped-up' in Maya transformers. Hidden from the Archaeologist and the grave robber. Hidden from the searcher and thinker.

But it was another gift from Jesus that caused his fame to spread; he could heal the sick with his bare hands, or simply with his Will. Like the other Supergods, Jesus worked miracles; 34 ascribed to him are set down in the Gospels. He appeared to overcome physical laws to achieve super-human results for his efforts and, in addition, to have a deep insight into the foundations of physical nature and the influence of mind over matter that was not of this world.

blasphemy, despite the pleas from Joseph of Arimathea and others.

The Romans, unsure as to what action to take, threw open the fate of Jesus to a referendum where the consensus called for punishment of death by crucifixion. The outcome had not taken Jesus by surprise. The previous night, fearful of the events unfolding, he held a farewell supper with his twelve Disciples:

Jesus took bread, and blessed, and brake it, and gave to them, and said, take, eat: this is my body. And he took the cup [filled with wine] and when he had given thanks, he gave it to them; and they drank of it. And he said unto them, 'this is my blood of the New Testament, which is shed for many'. (*Mark XIV, 22-24*)

Then Jesus foretold the events overtaking them saying:

All ye shall be offended because of me this night: for it is written, I will smite the shepherd, and the sheep of the flock shall be scattered abroad. (*Matthew XXVI, 31*)

And he spoke of imminent betrayal from one within the group:

... that the scripture may be fulfilled, he that eateth bread with me hath lifted up his heel against me... Verily, verily, I say unto you, that one of you shall betray me. (*John XIII, 18-21*) [The scripture Jesus was referring to was that from the Old Testament book of Psalms (XXXI, 9): 'Yea, mine own familiar friend, in whom I trusted, which did eat of my bread, hath lifted up his heel against me'].

Then one of the twelve, called Judas Iscariot, went unto the chief priests and said unto them:

What will you give me and I will deliver him unto you: And they covenanted with him for thirty pieces of silver (*Matthew XXVI, 14-15*). Then Judas, who had betrayed him... repented... and he cast down the pieces of silver in the temple... and the chief priests took the pieces of silver... and bought with them the potter's field, to bury strangers in. (*Matthew XXVII, 3-7*)

Thus fulfilling the Old Testament prophecy:

They weighed for me my price, thirty pieces of silver. And the

As the fame of Jesus and his teachings spread he became known as the 'King of the Jews' among followers. The Jewish clergy objected, insisting that he did not conform to their perception of a Messiah. After all, he was the son of a poor carpenter, born in a stable, who did not have the credentials to call himself King. How, they questioned, could this man Jesus say he was the Son of God? As far as the Jews were concerned this was blasphemy.

For their part the Romans had no axe to grind on the subject of Jesus or religion, they were more concerned with maintaining law and order and with it the uninterrupted flow of taxes. But Jesus's adversaries conspired to entrap him and the Sanhedrin found him guilty of blasphemy, despite the pleas from Joseph of Aramathea and others.

The Romans, unsure as to what action to take, threw open the fate of Jesus to a referendum where the consensus called for punishment of death by crucifixion. The outcome had not taken Jesus by surprise. The previous night, fearful of the events unfolding, he held a farewell supper with his twelve Disciples;

Jesus took bread, and blessed, and brake it, and gave to them, and said, take, eat: this is my body. And he took the cup [filled with wine] and when he had given thanks, he gave it to them; and they drank of it. And he said unto them, 'this is my blood of the New Testament, which is shed for many' (*Mark XIV, 22-24*).

Then Jesus foretold the events overtaking them saying:

All ye shall be offended because of me this night: for it is written, I will smite the shepherd, and the sheep of the flock shall be scattered abroad (*Matthew XXVI, 31*).

And he spoke of imminent betrayal from one within the group:

...that the scripture may be fulfilled, he that eateth bread with me hath lifted up his heel against me... Verily, verily, I say unto you, that one of you shall betray me. (*John XIII, 18-21*). [The scripture Jesus was referring to was that from the Old Testament book of Psalms (XXXI, 9): 'Yea, mine own familiar friend, in whom I trusted, which did eat of my bread, hath lifted up his heel against me'].

Then one of the twelve, called Judas Iscariot, went unto the chief priests

Lord said unto me, cast it unto the potter . . . and I took the thirty pieces of silver and cast them to the potter in the house of the Lord. (Zechariah XI, 12-13)

And the high priest arose, and said unto him, 'Answerest thou nothing? What is it which these witness against thee?' But Jesus held his peace. . . . Then the high priest [said] 'What think ye?' They answered and said, 'he is guilty of death'. Then did they spit in his face, and buffeted him with the palms of their hands. . . . And Jesus stood before . . . the Governor . . . and when he was accused of the chief priests and elders, he answered nothing. (Matthew XXVI, 62-67; XXVII, 11-12)

He is despised and rejected of men; a man of sorrows . . . he was wounded for our transgressions, he was bruised for our iniquities . . . He was oppressed and he was afflicted, yet he opened not his mouth: he is brought as a lamb to the slaughter, and as a sheep before her shearer is dumb, so he openeth not his mouth. He was taken from prison and from Judgement . . . he was cut off out of the land of the living: for the transgressions of my people was he stricken. (Isaiah LIII, 3-8)

And they crucified him . . . And they that passed-by reviled him . . . 'he saved others; himself he cannot save' . . . And about the ninth hour cried with a loud voice, 'My God, my God, why has thou forsaken me?' (Matthew XXVII, 35-46)

My God, my God why has thou forsaken me? . . . he trusted on the Lord that he would deliver him: let him deliver him . . . I am poured out like water and my bones are out of joint . . . my tongue cleaveth to my jaws, and thou has brought me into the dust of death . . . they pierced my hands and my feet . . . they part my garments among them and cast lots upon my vesture. (Psalms XXII, 1-18)

Now there was a vessel full of vinegar: and they filled a sponge with vinegar, and put it upon a hyssup, and put it to his mouth . . . When Jesus had therefore received the vinegar he said 'it is finished' and he bowed his head and gave up the Ghost . . . When they came to Jesus, and saw he was already dead . . . one of the soldiers with

a spear pierced his side and forthwith came there out blood and water. And he that saw it bare record, and his record is true . . . for these things were done that the scripture be fulfilled; A bone of him shall not be broken. And again another scripture saith; they shall look on him whom they pierced. (John XIX, 29-36)

Many are the afflictions of the righteous: but the Lord delivereth him out of them all. He keepeth all his bones: not one of them is broken. (Psalms XXXIV, 19-20)

When the even was come, there came a rich man of Aramathea, named Joseph, who also himself was Jesus' Disciple: he went to Pilate, and begged the body of Jesus . . . he wrapped it in a clean linen cloth, and laid it out in his own tomb, which he had hewn out of the rock. (Matthew XXVII, 57-60)

Jesus taught that the hidden purpose of life was to purify the heart (figure 28). A pure heart purifies the soul and a pure soul goes to Heaven



The Pure of Heart

Figure 28. Jesus, pointing to his exposed pure heart that radiates light. The halo around his head carries the four-sector solar cross.

THE CELTIC CHRONICLES

and said unto them;

What will you give me and I will deliver him unto you: And they covenanted with him for thirty pieces of silver. (Matthew XXVI, 14-15). Then Judas, who had betrayed him . . . repented . . . and he cast down the pieces of silver in the temple . . . and the chief priests took the pieces of silver . . . and bought with them the potter's field, to bury strangers in. (Matthew XXVII, 3-7).

Thus fulfilling the Old Testament prophecy;

They weighed for me my price, thirty pieces of silver. And the Lord said unto me, cast it unto the potter . . . and I took the thirty pieces of silver and cast them to the potter in the house of the Lord. (Zechariah XI, 12-13).

And the high priest arose, and said unto him, 'Answerest thou nothing? What is it which these witness against thee?' But Jesus held his peace. . . . Then the high priest [said] 'What think ye?' They answered and said, 'he is guilty of death'. Then did they spit in his face, and buffeted him with the palms of their hands. . . . And Jesus stood before . . . the Governor . . . and when he was accused of the chief priests and elders, he answered nothing. (Matthew XXVI, 62-67; XXVII, 11-12).

He is despised and rejected of men; a man of sorrows . . . he was wounded for our transgressions, he was bruised for our iniquities. . . . He was oppressed and he was afflicted, yet he opened not his mouth: he is brought as a lamb to the slaughter, and as a sheep before her shearer is dumb, so he openeth not his mouth. He was taken from prison and from Judgement . . . he was cut off out of the land of the living: for the transgressions of my people was he stricken. (Isiah LIII, 3-8).

And they crucified him. . . . And they that passed-by reviled him. . . . 'he saved others; himself he cannot save' And about the ninth hour cried with a loud voice, 'My God, my God, why has thou forsaken me?' (Matthew XXVII, 35-46).

My God, my God why has thou forsaken me? . . . he trusted on the Lord that he

Central Library, Henry Street, An Lárleabharlann, Sráid Anríochí Tel: 8734333

would deliver him: let him deliver him. . . . I am poured out like water and my bones are out of joint. . . . my tongue cleaveth to my jaws, and thou has brought me into the dust of death. . . . they pierced my hands and my feet. . . . they part my garments among them and cast lots upon my vesture (Psalms XXII, 1-18).

Now there was a vessel full of vinegar: and they filled a sponge with vinegar, and put it upon a hyssup, and put it to his mouth. . . . When Jesus had therefore received the vinegar he said 'it is finished' and he bowed his head and gave up the Ghost. . . . When they came to Jesus, and saw he was already dead. . . . one of the soldiers with a spear pierced his side and forthwith came there out blood and water. And he that saw it bare record, and his record is true. . . . for these things were done that the scripture be fulfilled; A bone of him shall not be broken. And again another scripture saith; they shall look on him whom they pierced. (John XIX, 29-36).

Many are the afflictions of the righteous: but the Lord delivereth him out of them all. He keepeth all his bones: not one of them is broken (Psalms XXXIV, 19-20).

When the even was come, there came a rich man of Aramathea, named Joseph, who also himself was Jesus' Disciple: he went to Pilate, and begged the body of Jesus. . . . he wrapped it in a clean linen cloth, and laid it out in his own tomb, which he had hewn out of the rock. (Matthew XXVII, 57-60).

Jesus taught that the hidden purpose of life was to purify the heart (figure 28). A pure heart purifies the soul and a pure soul goes to Heaven to experience peace, joy and bliss with the creator. The way to a pure heart was through love, sacrifice and suffering.

This is another way of saying that the electromagnetic energy of God, the soul—detached from its Godly source—must always be in a state of permanent disequilibrium while inside the body—as a raised rock will always be attracted to the ground so the pure soul will always be attracted back to Heaven, from whence it came.

Many believe that the Egyptian practice of mummification facilitated the reincarnation process should the soul of the deceased return to Earth.

Lord said unto me, cast it unto the potter . . . and I took the thirty pieces of silver and cast them to the potter in the house of the Lord. (*Zechariah XI, 12-13*)

And the high priest arose, and said unto him, 'Answerest thou nothing? What is it which these witness against thee?' But Jesus held his peace. . . . Then the high priest [said] 'What think ye?' They answered and said, 'he is guilty of death'. Then did they spit in his face, and buffeted him with the palms of their hands. . . . And Jesus stood before . . . the Governor . . . and when he was accused of the chief priests and elders, he answered nothing. (*Matthew XXVI, 62-67; XXVII, 11-12*)

He is despised and rejected of men; a man of sorrows . . . he was wounded for our transgressions, he was bruised for our iniquities . . . He was oppressed and he was afflicted, yet he opened not his mouth: he is brought as a lamb to the slaughter, and as a sheep before her shearer is dumb, so he openeth not his mouth. He was taken from prison and from Judgement . . . he was cut off out of the land of the living; for the transgressions of my people was he stricken. (*Isaiah LIII, 3-8*)

And they crucified him . . . And they that passed-by reviled him . . . 'he saved others; himself he cannot save' . . . And about the ninth hour cried with a loud voice, 'My God, my God, why has thou forsaken me?' (*Matthew XXVII, 35-46*)

My God, my God why has thou forsaken me? . . . he trusted on the Lord that he would deliver him: let him deliver him . . . I am poured out like water and my bones are out of joint . . . my tongue cleaveth to my jaws, and thou has brought me into the dust of death . . . they pierced my hands and my feet . . . they part my garments among them and cast lots upon my vesture. (*Psalms XXII, 1-18*)

Now there was a vessel full of vinegar: and they filled a sponge with vinegar, and put it upon a hyssop, and put it to his mouth . . . When Jesus had therefore received the vinegar he said 'it is finished' and he bowed his head and gave up the Ghost . . . When they came to Jesus, and saw he was already dead . . . one of the soldiers with

But the Egyptians also preserved the internal organs, apart from the heart and the brain, and in so doing explained that an old brain in a new life is of no value, because a new brain has an empty memory. In the same way, a new heart has no emotional memory. In the next life our intellectual and emotional life start from the beginning, not from where we left off. Reincarnates cannot benefit from previous knowledge which, as we have already heard, is why the ancients encoded their knowledge into their treasures for themselves to rediscover should they not make it to Heaven this time around.

The inference here is that the heart, too, *must* have memory, 'emotional memory'. The brain remembers facts and figures, the super-science of the Sun, but it is the Heart that remembers the love given and gained, won and lost. Indeed, when we review our lives, our successes and failures, it is not the houses, cars or jobs that come to mind but the regret, remorse, joy and happiness of the relationships with living things.

A computer memory stores data by electronically processing information and stacking it in memory cells that retain the electrical charge for later retrieval. The heart therefore must store emotional information in the heart organ using electrical charge in the same way. There are documented accounts from modern heart-transplant patients who have experienced recall of how the heart donor died, perhaps by being shot dead, or killed in a car accident. The heart is a dynamic organ that can take us to Heaven.

The late-Celtic Rinnagan Crucifixion plaque (figure 29), a beaten bronze plaque from the cover of a lost seventh-century theological manuscript, was found in a churchyard in County Roscommon, Ireland. It shows the Crucifixion of Christ with Longinus—the Roman soldier who pierced the side of Christ with a sword—and Stepaton, to his left, offering a vinegar-soaked sponge to the lips of Christ. Either side of his head two angels appear as the morning star and the evening star. The treasured Celtic relic is nowadays kept in the National Museum of Ireland in Dublin. Archaeologists are perplexed as to why the plaque shows Christ with Celtic spirals swirling around his chest, and around his head, and why they also feature on the angels either side of him.

a spear pierced his side and forthwith came there out blood and water. And he that saw it bare record, and his record is true . . . for these things were done that the scripture be fulfilled; A bone of him shall not be broken. And again another scripture saith; they shall look on him whom they pierced. (*John XIX, 29-36*)

Many are the afflictions of the righteous: but the Lord delivereth him out of them all. He keepeth all his bones: not one of them is broken. (*Psalms XXXIV, 19-20*)

When the even was come, there came a rich man of Aramathea, named Joseph, who also himself was Jesus' Disciple: he went to Pilate, and begged the body of Jesus . . . he wrapped it in a clean linen cloth, and laid it out in his own tomb, which he had hewn out of the rock. (*Matthew XXVII, 57-60*)

Jesus taught that the hidden purpose of life was to purify the heart (figure 28). A pure heart purifies the soul and a pure soul goes to Heaven

The Pure of Heart

Figure 28. Jesus, pointing to his exposed pure heart that radiates light. The halo around his head carries the four-sector solar cross.



The Pure of Heart

Figure 28. (a) Jesus, pointing to his exposed pure heart that radiates light. The Halo around his head carries the four-sector solar cross.



The Lost Meaning of the Celtic Spiral

The Bhagava Gita states that God is light. God, therefore, must be the Sun. The human soul, as part of God, must therefore also be the Sun in a slightly different form (as water might be steam or ice). Figure 30a shows the magnetic structure of the Sun. Figure 30b shows the positive and negative distribution of magnetic energy present in a cross-section slice taken around the equatorial region. The energy spirals carved into the heart centre of Christ on the Rinnagan Crucifixion plaque (figure 30c) correspond exactly to the Sun's energy (figure 30b); two quadrants each comprise of a two-part spiral, the yin and yang, the dark and light principles of energy that the ancient Chinese believed to be inherent in all living things.

As we have seen, the Sun's equatorial region (figure 30a) rotates once every 26 days (28 days to an observer on Earth) and the Sun's polar magnetic caps rotate once every 37 days (41 days to an observer on Earth).

Lord said unto me, cast it unto the potter . . . and I took the thirty pieces of silver and cast them to the potter in the house of the Lord. (*Zechariah XI, 12-13*)

And the high priest arose, and said unto him, 'Answerest thou nothing? What is it which these witness against thee?' But Jesus held his peace. . . . Then the high priest [said] 'What think ye?' They answered and said, 'he is guilty of death'. Then did they spit in his face, and buffeted him with the palms of their hands. . . . And Jesus stood before . . . the Governor . . . and when he was accused of the chief priests and elders, he answered nothing. (*Matthew XXVI, 62-67; XXVII, 11-12*)

He is despised and rejected of men; a man of sorrows . . . he was wounded for our transgressions, he was bruised for our iniquities . . . He was oppressed and he was afflicted, yet he opened not his mouth: he is brought as a lamb to the slaughter, and as a sheep before her shearer is dumb, so he openeth not his mouth. He was taken from prison and from judgement . . . he was cut off out of the land of the living; for the transgressions of my people was he stricken. (*Isaiah LIII, 3-8*)

And they crucified him . . . And they that passed-by reviled him . . . 'he saved others; himself he cannot save' . . . And about the ninth hour cried with a loud voice, 'My God, my God, why has thou forsaken me?' (*Matthew XXVII, 35-46*)

My God, my God why has thou forsaken me? . . . he trusted on the Lord that he would deliver him: let him deliver him . . . I am poured out like water and my bones are out of joint . . . my tongue cleaveth to my jaws, and thou has brought me into the dust of death . . . they pierced my hands and my feet . . . they part my garments among them and cast lots upon my vesture. (*Psalms XXII, 1-18*)

Now there was a vessel full of vinegar; and they filled a sponge with vinegar, and put it upon a hyssop, and put it to his mouth . . . When Jesus had therefore received the vinegar he said 'it is finished' and he bowed his head and gave up the Ghost . . . When they came to Jesus, and saw he was already dead . . . one of the soldiers with

But the Egyptians also preserved the internal organs, apart from the heart and the brain, and in so doing explained that an old brain in a new life is of no value, because a new brain has an empty memory. In the same way, a new heart has no emotional memory. In the next life our intellectual and emotional life start from the beginning, not from where we left off. Reincarnates cannot benefit from previous knowledge which, as we have already heard, is why the ancients encoded their knowledge into their treasures for themselves to rediscover should they not make it to Heaven this time around.

The inference here is that the heart, too, must have memory, 'emotional memory'. The brain remembers facts and figures, the super-science of the Sun, but it is the Heart that remembers the love given and gained, won and lost. Indeed, when we review our lives, our successes and failures, it is not the houses, cars or jobs that come to mind but the regret, remorse, joy and happiness of the relationships with living things.

A computer memory stores data by electronically processing information and stacking it in memory cells that retain the electrical charge for later retrieval. The heart therefore must store emotional information in the heart organ using electrical charge in the same way. There are documented accounts from modern heart-transplant patients who have experienced recall of how the heart donor died, perhaps by being shot dead, or killed in a car accident. The heart is a dynamic organ that can take us to Heaven.

The late Celtic Rinnagan Crucifixion plaque (figure 29), a beaten bronze plaque from the cover of a lost seventh century theological manuscript, was found in a churchyard in County Roscommon, Ireland. It shows the Crucifixion of Christ with Longinus—the Roman soldier who pierced the side of Christ with a sword—and Stephaon, to his left, offering a vinegar-soaked sponge to the lips of Christ. Either side of his head two angels appear as the morning star and the evening star. The treasure Celtic relic is nowadays kept in the National Museum of Ireland in Dublin. Archaeologists are perplexed as to why the plaque shows Christ with Celtic spirals swirling around his chest, and around his head, and why they also feature on the angels either side of him.

a spear pierced his side and forthwith came there out blood and water. And he that saw it bare record, and his record is true . . . for these things were done that the scripture be fulfilled; A bone of him shall not be broken. And again another scripture saith; they shall look on him whom they pierced. (*John XIX, 29-36*)

Many are the afflictions of the righteous; but the Lord delivereth him out of them all. He keepeth all his bones: not one of them is broken. (*Psalms XXXIV, 19-20*)

When the even was come, there came a rich man of Aramathea, named Joseph, who also himself was Jesus' Disciple: he went to Pilate, and begged the body of Jesus . . . he wrapped it in a clean linen cloth, and laid it out in his own tomb, which he had hewn out of the rock. (*Matthew XXVII, 57-60*)

Jesus taught that the hidden purpose of life was to purify the heart (figure 28). A pure heart purifies the soul and a pure soul goes to Heaven

The Pure of Heart

Figure 28 Jesus, pointing to his exposed pure heart that radiates light. The halo around his head carries the four-sector solar cross.



The Pure of Heart

Figure 28 (a) Jesus, pointing to his exposed pure heart that radiates light. The Halo around his head carries the four-sector solar cross.



The Lost Meaning of the Celtic Spiral

The Bhagava Gita states that God is light. God, therefore, must be the Sun. The human soul, as part of God, must therefore also be the Sun in a slightly different form (as water might be steam or ice). Figure 30a shows the magnetic structure of the Sun. Figure 30b shows the positive and negative distribution of magnetic energy present in a cross section slice taken around the equatorial region. The energy spirals carved into the heart centre of Christ on the Rinnagan Crucifixion plaque (figure 30c) correspond exactly to the Sun's energy (figure 30b); two quadrants each comprise of a two-part spiral, the yin and yang, the dark and light principles of energy that the ancient Chinese believed to be inherent in all living things.

As we have seen, the Sun's equatorial region (figure 30a) rotates once every 26 days (28 days to an observer on Earth) and the Sun's polar magnetic caps rotate once every 37 days (41 days to an observer on Earth).

to experience peace, joy and bliss with the creator. The way to a pure heart was through love, sacrifice and suffering.

This is another way of saying that the electromagnetic energy of God, the soul—detached from its godly source—must always be in a state of permanent disequilibrium while inside the body—as a raised rock will always be attracted to the ground, so the pure soul will always be attracted back to Heaven, from whence it came.

Many believe that the Egyptian practise of mummification facilitated the reincarnation process should the soul of the deceased return to Earth. But the Egyptians also preserved the internal organs, apart from the heart and the brain, and in so doing explained that an old brain in a new life is of no value, because a new brain has an empty memory. In the same way, a new heart has no emotional memory. In the next life our intellectual and emotional life start from the beginning, not from where we left off. Reincarnates cannot benefit from previous knowledge which, as we have already heard, is why the ancients encoded their knowledge into their treasures for themselves to rediscover should they not make it to Heaven this time around.

The inference here is that the heart, too, *must* have memory, 'emotional memory'. The brain remembers facts and figures, the super-science of the Sun, but it is the Heart that remembers the love given and gained, won and lost. Indeed, when we review our lives, our successes and failures, it is not the houses, cars or jobs that come to mind but the regret, remorse, joy and happiness of the relationships with living things.

A computer memory stores data by electronically processing information and stacking it in memory cells that retain the electrical charge for later retrieval. The heart therefore must store emotional information in the heart organ using electrical charge in the same way. There are documented accounts from modern heart-transplant patients who have experienced recall of how the heart donor died, perhaps by being shot dead, or killed in a car accident. The heart is a dynamic organ that can take us to Heaven.

The late-Celtic Rinnagan Crucifixion plaque (figure 29), a beaten bronze plaque from the cover of a lost seventh-century theological manuscript, was found in a churchyard in County Roscommon, Ireland. It shows the Crucifixion of Christ with Longinus—the Roman soldier who pierced the side of Christ with a sword—and Stephaton, to his

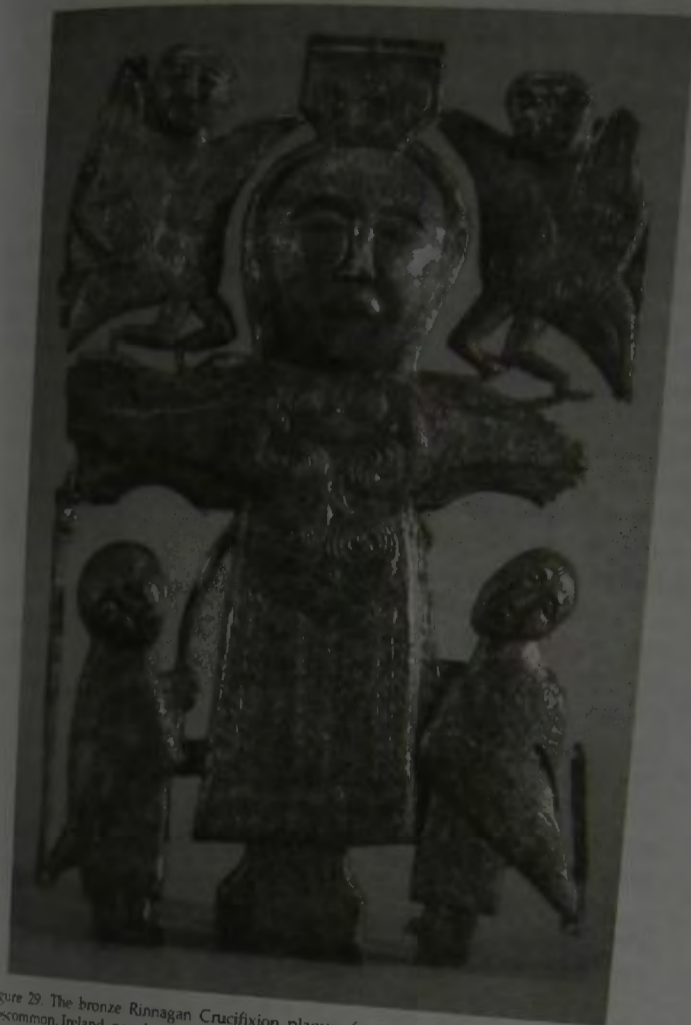

Figure 29. The bronze Rinnagan Crucifixion plaque, found in a churchyard in County Roscommon, Ireland, now kept in the Celtic collection of the National Museum of Ireland in Dublin. The scene shows the Crucifixion of Christ with, on his right, Longinus, who pierces the side of Christ with his sword. Stephaton, to his left, carries the vinegar-soaked sponge on a reed to the lips of Christ. The two angels above represent the twin-star (planet) Venus, the morning star and the evening star.

79

THE CELTIC CHRONICLES

At the same time, the Earth moves around the Sun once every year. The effect of the 'differential rotation' of the Sun's magnetic fields means that, every calendar month, one of the solar equatorial field sectors will be enlarged at the expense of its adjacent neighbour (figure 30b) resulting in the two equal quadrants (of ying and yang, mentioned above) and, in addition, two unequal quadrants.

The two-part ying and yang spirals (figure 30b) rotate in opposite directions, indicating the respective positive and negative field polarities undisturbed by the polar field during one particular month. The two unequal quadrants comprise of three-part spirals, each representing the adjacent field sectors that are disturbed by the rotating polar magnetic field each month. In this way the energy spirals featured on the heart of Christ, on the Rinnagan Crucifixion plaque (figure 30c) are hence shown to be identical to those of the Sun.

The magnetic interaction (for the month under examination) makes one heart-spiral quadrant more positive (shown as grey-grey-black) and the other more negative (shown as black-black-grey). The appearance of the spiral schematic on the heart of Christ shows that Christ's energy, the soul, is the same type of energy as the Sun and that the energy resides in the heart. That this is a reasonable interpretation of the Christ heart-spiral arrangement is supported by the appearance of the two miniature triple-spirals that appear above the four heart spirals; these two three-part spirals are mirror images of each other suggesting that the heart spirals represent the soul energy, the mirror image energy, in man.

Another distinction is emphasised by energy spirals located in the halo of Christ: these three two-part spirals are obtained by simple rotation, suggesting that the energy is something other than mirror image energy. Moreover, the tiny centre three-part halo spiral integrates the three two-part spirals into one three-part spiral.

The spiral markers on the Rinnagan Crucifixion plaque therefore highlight the difference between soul energy and Godly energy; soul energy is Godly energy (solar energy) which is attached to the heart of man whereas halo energy is pure Godly energy, light.

The spiral, or whorl, is a central feature in Celtic art, meaning that the Celts were preoccupied with purification of the soul—the conversion of soul energy to halo energy [the conversion of 666 to 999], the super-

The Crucifixion of Christ



Figure 29. The bronze Rinnagan Crucifixion plaque, found in a churchyard in County Roscommon, Ireland, now kept in the Celtic collection of the National Museum of Ireland in Dublin. The scene shows the crucifixion of Christ with, on his right, Longinus, who pierces the side of Christ with his sword. Stephaton, to his left, carries the vinegar-soaked sponge on a reed to the lips of Christ. The two angels above represent the twin-star (planet) Venus, the morning star and the evening star.

to experience peace, joy and bliss with the creator. The way to a pure heart was through love, sacrifice and suffering.

This is another way of saying that the electromagnetic energy of God, the soul—detached from its godly source—must always be in a state of permanent disequilibrium while inside the body—as a raised rock will always be attracted to the ground, so the pure soul will always be attracted back to Heaven, from whence it came.

Many believe that the Egyptian practise of mummification facilitated the reincarnation process should the soul of the deceased return to Earth. But the Egyptians also preserved the internal organs, apart from the heart and the brain, and in so doing explained that an old brain in a new life is of no value, because a new brain has an empty memory. In the same way, a new heart has no emotional memory. In the next life our intellectual and emotional life start from the beginning, not from where we left off. Reincarnates cannot benefit from previous knowledge which, as we have already heard, is why the ancients encoded their knowledge into their treasures for themselves to rediscover should they not make it to Heaven this time around.

The inference here is that the heart, too, *must* have memory, 'emotional memory'. The brain remembers facts and figures, the super-science of the Sun, but it is the Heart that remembers the love given and gained, won and lost. Indeed, when we review our lives, our successes and failures, it is not the houses, cars or jobs that come to mind but the regret, remorse, joy and happiness of the relationships with living things.

A computer memory stores data by electronically processing information and stacking it in memory cells that retain the electrical charge for later retrieval. The heart therefore must store emotional information in the heart organ using electrical charge in the same way. There are documented accounts from modern heart-transplant patients who have experienced recall of how the heart donor died, perhaps by being shot dead, or killed in a car accident. The heart is a dynamic organ that can take us to Heaven.

The late-Celtic Rinnagan Crucifixion plaque (figure 29), a beaten bronze plaque from the cover of a lost seventh-century theological manuscript, was found in a churchyard in County Roscommon, Ireland. It shows the Crucifixion of Christ with Longinus—the Roman soldier—who pierced the side of Christ with a sword—and Stephaton, to his

The Crucifixion of Christ



Figure 29. The bronze Rinnagan Crucifixion plaque, found in a churchyard in County Roscommon, Ireland, now kept in the Celtic collection of the National Museum of Ireland in Dublin. The scene shows the Crucifixion of Christ with, on his right, Longinus, who pierces the side of Christ with his sword. Stephaton, to his left, carries the vinegar-soaked sponge on a reed to the lips of Christ. The two angels above represent the twin-star (planet) Venus, the morning star and the evening star.

THE CELTIC CHRONICLES

At the same time, the Earth moves around the Sun once every year. The effect of the 'differential rotation' of the Sun's magnetic field sectors will be enlarged at the expense of its adjacent neighbour (figure 30b) resulting in the two equal quadrants (of ying and yang, mentioned above) and, in addition, two unequal quadrants.

The two-part ying and yang spirals (figure 30b) rotate in opposite directions, indicating the respective positive and negative field polarities undisturbed by the polar field during one particular month. The two unequal quadrants comprise of three-part spirals, each representing the adjacent field sectors that are disturbed by the rotating polar magnetic field each month. In this way the energy spirals featured on the heart of Christ, on the Rinnagan Crucifixion plaque (figure 30c) are hence shown to be identical to those of the Sun.

The magnetic interaction (for the month under examination) makes one heart-spiral quadrant more positive (shown as grey-grey-black) and the other more negative (shown as black-black-grey). The appearance of the spiral schematic on the heart of Christ shows that Christ's energy, the soul, is the same type of energy as the Sun and that the energy resides in the heart. That this is a reasonable interpretation of the Christ heart-spiral arrangement is supported by the appearance of the two miniature triple spirals that appear above the four heart spirals; these two heart spirals represent the soul energy, the mirror image energy, in man.

Another distinction is emphasised by energy spirals located in the halo of Christ; these three two-part spirals are obtained by simple rotation, suggesting that the energy is something other than mirror image energy. Moreover, the tiny centre three-part halo spiral integrates the three two-part spirals into one three-part spiral.

The spiral markers on the Rinnagan Crucifixion plaque therefore highlight the difference between soul energy and Godly energy: soul energy is Godly energy (solar energy) which is attached to the heart of man whereas halo energy is pure Godly energy, light.

The spiral, or whorl, is a central feature in Celtic art, meaning that the Celts were preoccupied with purification of the soul—the conversion of soul energy to halo energy (the conversion of 666 to 999), the super-

The Crucifixion of Christ



Figure 29. The bronze Rinnagan Crucifixion plaque, found in a churchyard in County Roscommon, Ireland, now kept in the Celtic collection of the National Museum of Ireland in Dublin. The scene shows the crucifixion of Christ with, on his right, Longinus, who pierces the side of Christ with his sword. Stephaton, to his left, carries the vinegar-soaked sponge on a reed to the lips of Christ. The two angels above represent the twin-star (planet) Venus, the morning star and the evening star.

left, offering a vinegar-soaked sponge to the lips of Christ. Either side of his head two angels appear as the morning star and the evening star. The treasured Celtic relic is nowadays kept in the National Museum of Ireland in Dublin. Archaeologists are perplexed as to why the plaque shows Christ with Celtic spirals swirling around his chest, and around his head, and why they also feature on the angels either side of him.

The Lost Meaning of the Celtic Spiral

The Bhagavad Gita states that God is light. God, therefore, must be the Sun. The human soul, as part of God, must therefore also be the Sun in a slightly different form (as water might be steam or ice). Figure 30a shows the magnetic structure of the Sun. Figure 30b shows the positive and negative distribution of magnetic energy present in a cross-section slice taken around the equatorial region. The energy spirals carved into the heart centre of Christ on the Rinnagan Crucifixion plaque (figure 30c) correspond exactly to the Sun's energy (figure 30b): two quadrants each composed of a two-part spiral, the yin and yang, the dark and light principles of energy that the ancient Chinese believed to be inherent in all living things.

As we have seen, the Sun's equatorial region (figure 30a) rotates once every twenty-six days (twenty-eight days to an observer on Earth) and the Sun's polar magnetic caps rotate once every thirty-seven days (forty-one days to an observer on Earth). At the same time, the Earth moves around the Sun once every year. The effect of the 'differential rotation' of the Sun's magnetic fields means that every calendar month, one of the solar equatorial field sectors will be enlarged at the expense of its adjacent neighbour (figure 30b) resulting in the two equal quadrants (of yin and yang, mentioned above) and, in addition, two unequal quadrants.

The two-part yin and yang spirals (figure 30b) rotate in opposite directions, indicating the respective positive and negative field polarities undisturbed by the polar field during one particular month. The two unequal quadrants consist of three-part spirals, each representing the adjacent field sectors that are disturbed by the rotating polar magnetic field each month. In this way the energy spirals featured on the heart of Christ, on the Rinnagan Crucifixion plaque (figure 30c), are hence shown to be identical to those of the Sun.

science of the Sun, and the higher orders of spirituality.

The re-distribution of energy (figure 30b) can be analysed more simply, as in Figure 31; here the reduced quadrant is considered 'neutralised' (N) each month. This is to say that an observer on Earth sees only three of the four quadrants in any one month (30.4375 days). The radiation of solar particles (positive and negative charges) leads to twelve different sequences of magnetic modulations of the Earth's magnetic field resulting in twelve types of genetic mutations in early impregnated ovum and the consequential development of twelve different personality types each year (Sun-sign astrology). In addition, the radiation patterns are detected by the human brain causing variations in levels of the timing hormone melatonin and variations in the production of the fertility hormones, oestrogen and progesterone, and the consequential regulation of menstruation and fertility in females—which is why the ancients worshipped the Sun as the God of Astrology and the God of Fertility.

The four-part heart spiral was represented by the Hallstatt Celts as the reverse swastika (figure 32a). The tri-part halo energy spiral arrangement refers to the solar wind after equatorial field sector neutralisation. Those who increase their own soul voltage during their lifetime on Earth go to Heaven. The tri-part spiral was depicted by the Celts as the three-legged symbol of Man (figure 32b), the National emblem of the Celtic people, the Manx, of the Isle of Man³⁵.

After the Crucifixion

Following the Crucifixion the body of Jesus was laid to rest in the tomb previously prepared for Joseph of Aramathea. Pontius Pilate, fearful of claims of martyrdom should the body being taken, arranged for the opening of the sepulchre to be blocked by a large rock and for two Roman Centurions to stand guard.

The next day Mary Magdalene—who some say was the closest of anyone to Jesus—visited the tomb. The Centurions were dead. The large rock that had blocked the tomb had been rolled away exposing the open entrance.

After the death there was a great earthquake for the angel of the Lord rolled back the stone. Flowers and garlands rolled back the stone from the tomb and the centurions were dead for fear of him the keepers [guards] did

The Crucifixion of Christ (II)

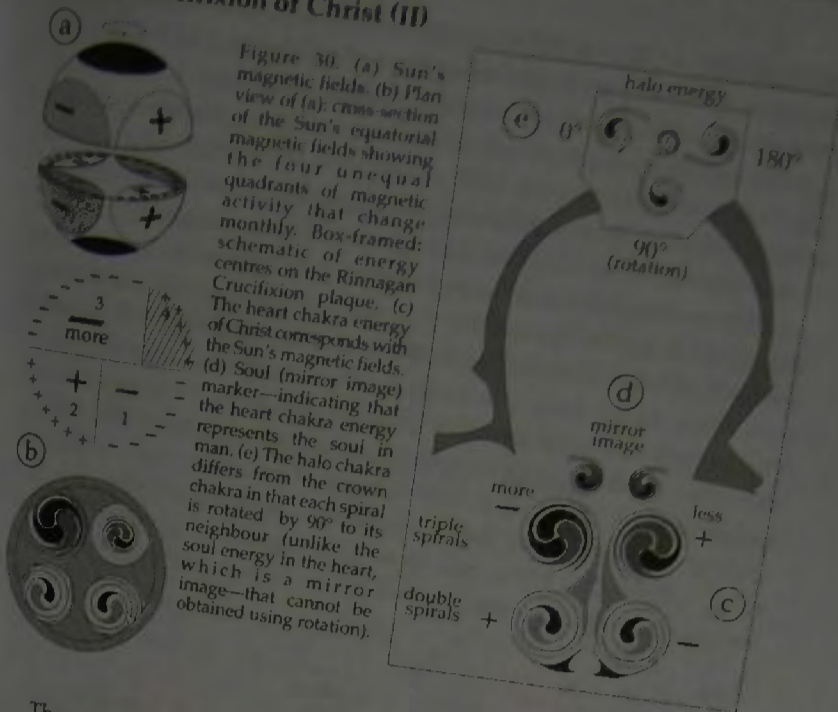

Figure 30. (a) Sun's magnetic fields. (b) Plan view of (a); cross-section of the Sun's equatorial magnetic fields showing the four unequal quadrants of magnetic activity that change monthly. Box-framed; schematic of energy centres on the Rinnagan Crucifixion plaque. (c) The heart chakra energy of Christ corresponds with the Sun's magnetic fields. (d) Soul (mirror image) marker—indicating that the heart chakra energy represents the soul in man. (e) The halo chakra differs from the crown chakra in that each spiral is rotated by 90° to its neighbour (unlike the soul energy in the heart, which is a mirror image—that cannot be obtained using rotation).

The magnetic interaction (for the month under examination) makes one heart-spiral quadrant more positive (shown as grey-grey-black) and the other more negative (shown as black-black-grey). The appearance of the spiral schematic on the heart of Christ shows that Christ's energy, the soul, is the same type of energy as the Sun and that the energy resides in the heart. That this is a reasonable interpretation of the Christ heart-spiral arrangement is supported by the appearance of the two miniature triple spirals that appear above the four heart spirals; these two three-part spirals are mirror images of each other, suggesting that the heart spirals represent the soul energy, the mirror-image energy, in man.

Another distinction is emphasised by energy spirals located in the halo of Christ; these three two-part spirals are obtained by simple rotation, suggesting that the energy is something other than mirror-image energy. Moreover, the tiny centre three-part spiral integrates the three two-part spirals into one three-part spiral.

The spiral markers on the Rinnagan Crucifixion plaque therefore

The Crucifixion of Christ (II)

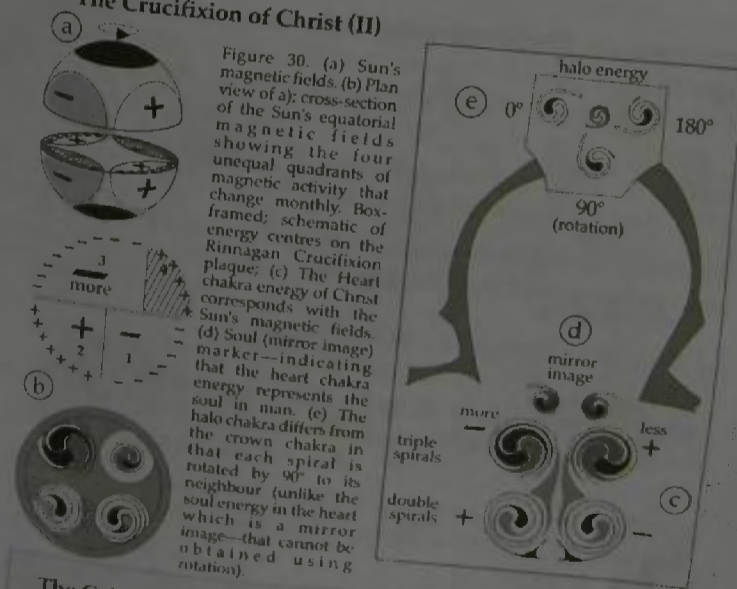

Figure 30. (a) Sun's magnetic fields. (b) Plan view of (a); cross-section of the Sun's equatorial magnetic fields showing the four unequal quadrants of magnetic activity that change monthly. Box-framed; schematic of energy centres on the Rinnagan Crucifixion plaque. (c) The heart chakra energy of Christ corresponds with the Sun's magnetic fields. (d) Soul (mirror image) marker—indicating that the heart chakra energy represents the soul in man. (e) The halo chakra differs from the crown chakra in that each spiral is rotated by 90° to its neighbour (unlike the soul energy in the heart, which is a mirror image—that cannot be obtained using rotation).

The Celts and Sun-sign Astrology		Monthly equatorial field sector disturbance caused by poles	Radiation pattern sequence—Neutralised by poles	Month	Element	Astrological Sign
	1234	123N	1	Fire	Aries	
	1234	123N	2	Earth	Taurus	
	1234	123N	3	Air	Gemini	
	1234	123N	4	Water	Cancer	
	1234	123N	5	Fire	Leo	
	1234	123N	6	Earth	Virgo	
	1234	123N	7	Air	Libra	
	1234	123N	8	Water	Scorpio	
	1234	123N	9	Fire	Sagittarius	
	1234	123N	10	Earth	Capricorn	
	1234	123N	11	Air	Aquarius	
	1234	123N	12	Water	Pisces	

Figure 31. The equatorial region of the Sun spins every 26 days. The polar magnetic caps spin once every 37 days. The Earth orbits the Sun every 365.25 days. This interaction causes neutralisation of a different equatorial field sector every month. The resulting solar wind radiation sequence travels to Earth and is trapped in the Van Allen radiation belts causing the Earth's magnetic field to vary at ground level (figure 8). The magnetic modulations affect the production of Oestrogen and Progesterone in females regulating the menstrual cycle and causing genetic mutations in early impregnated ovum—by rearranging sections of DNA—producing 12 different personality types throughout each year, which is why the ancients worshipped the Sun as the God of Fertility and the God of [Sun-sign] Astrology.

left, offering a vinegar-soaked sponge to the lips of Christ. Either side of his head two angels appear as the morning star and the evening star. The treasured Celtic relic is nowadays kept in the National Museum of Ireland in Dublin. Archaeologists are perplexed as to why the plaque shows Christ with Celtic spirals swirling around his chest, and around his head, and why they also feature on the angels either side of him.

The Lost Meaning of the Celtic Spiral

The Bhagavad Gita states that God is light. God, therefore, must be the Sun. The human soul, as part of God, must therefore also be the Sun in a slightly different form (as water might be steam or ice). Figure 30a shows the magnetic structure of the Sun. Figure 30b shows the positive and negative distribution of magnetic energy present in a cross-section the heart centre of Christ on the Rinnagan Crucifixion plaque carved into the heart centre of Christ on the Rinnagan Crucifixion plaque (figure 30c) correspond exactly to the Sun's energy (figure 30b); two quadrants each composed of a two-part spiral, the yin and yang, the dark inherent in all living things.

As we have seen, the Sun's equatorial region (figure 30a) rotates once every twenty-six days (twenty-eight days to an observer on Earth) and the Sun's polar magnetic caps rotate once every thirty-seven days (forty-one days to an observer on Earth). At the same time, the Earth moves around the Sun once every year. The effect of the 'differential rotation' of the Sun's magnetic fields means that every calendar month, one of the solar equatorial field sectors will be enlarged at the expense of its adjacent neighbour (figure 30b) resulting in the two equal quadrants (of yin and yang, mentioned above) and, in addition, two unequal quadrants.

The two-part yin and yang spirals (figure 30b) rotate in opposite directions, indicating the respective positive and negative field polarities undisturbed by the polar field during one particular month. The two unequal quadrants consist of three-part spirals, each representing the adjacent field sectors that are disturbed by the rotating polar magnetic field each month. In this way the energy spirals featured on the heart of Christ, on the Rinnagan Crucifixion plaque (figure 30c), are hence shown to be identical to those of the Sun.

The Crucifixion of Christ (II)

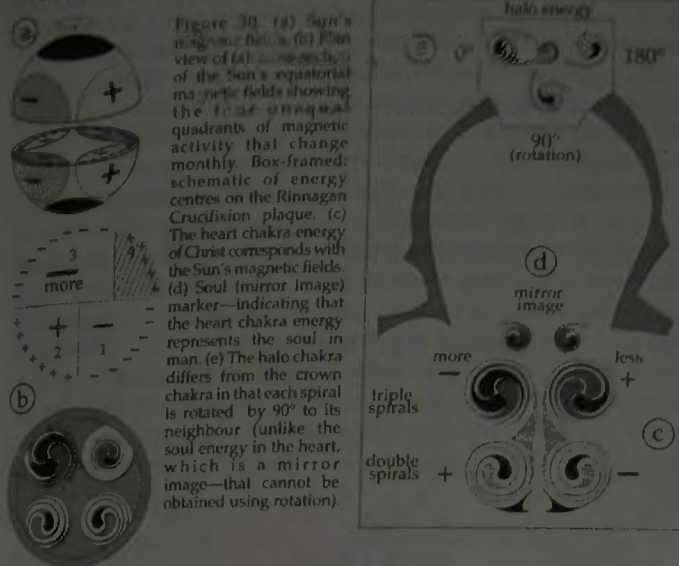

The magnetic interaction (for the month under examination) makes one heart-spiral quadrant more positive (shown as grey-grey-black) and the other more negative (shown as black-black-grey). The appearance of the spiral schematic on the heart of Christ shows that Christ's energy, the soul, is the same type of energy as the Sun and that the energy resides in the heart. That this is a reasonable interpretation of the Christ heart-spiral arrangement is supported by the appearance of the two miniature triple spirals that appear above the four heart spirals; these two three-part spirals are mirror images of each other, suggesting that the heart spirals represent the soul energy, the mirror-image energy, in man.

Another distinction is emphasised by energy spirals located in the halo of Christ; these three two-part spirals are obtained by simple rotation, suggesting that the energy is something other than mirror-image energy. Moreover, the tiny centre three-part halo spiral integrates the three two-part spirals into one three-part spiral.

The spiral markers on the Rinnagan Crucifixion plaque therefore

science of the Sun, and the higher orders of spirituality.

The re-distribution of energy (figure 30b) can be analysed more simply, as in Figure 31; here the reduced quadrant is considered 'neutralised' (N) each month. This is to say that an observer on Earth sees only three of the four quadrants in any one month (30.4375 days). The radiation of solar particles (positive and negative charges) leads to twelve different sequences of magnetic modulations of the Earth's magnetic field resulting in twelve types of genetic mutations in early impregnated ovum and the consequential development of twelve different personality types each year (Sun-sign astrology). In addition, the radiation patterns are detected by the human brain causing variations in levels of the timing hormone melatonin and variations in the production of the fertility hormones, oestrogen and progesterone, and the consequential regulation of menstruation and fertility in females—which is why the ancients worshipped the Sun as the God of Astrology and the God of Fertility.

The four-part heart spiral was represented by the Hallstatt Celts as the reverse swastika (figure 32ai). The tri-part halo energy spiral arrangement refers to the solar wind after equatorial field sector neutralisation. Those who increase their own soul voltage during their lifetime on Earth go to Heaven. The tri-part spiral was depicted by the Celts as the three-legged symbol of Man (figure 32bi), the National emblem of the Celtic people, the Manx, of the Isle of Man³⁵.

After the Crucifixion

Following the Crucifixion the body of Jesus was laid to rest in the tomb previously prepared for Joseph of Aramathea. Pontius Pilate, fearful of claims of martyrdom should the body being taken, arranged for the opening of the sepulchre to be blocked by a large rock and for two Roman Centurions to stand guard.

The next day Mary Magdalene—who some say was the closest of anyone to Jesus—visited the tomb. The Centurions were dead. The large rock that had blocked the tomb had been rolled away exposing the open entrance:

...And behold there was a great earthquake for the angel of the Lord descended from Heaven and came and rolled back the stone from the door and sat upon it...and for fear of him the keepers [guards] did

The Crucifixion of Christ (II)

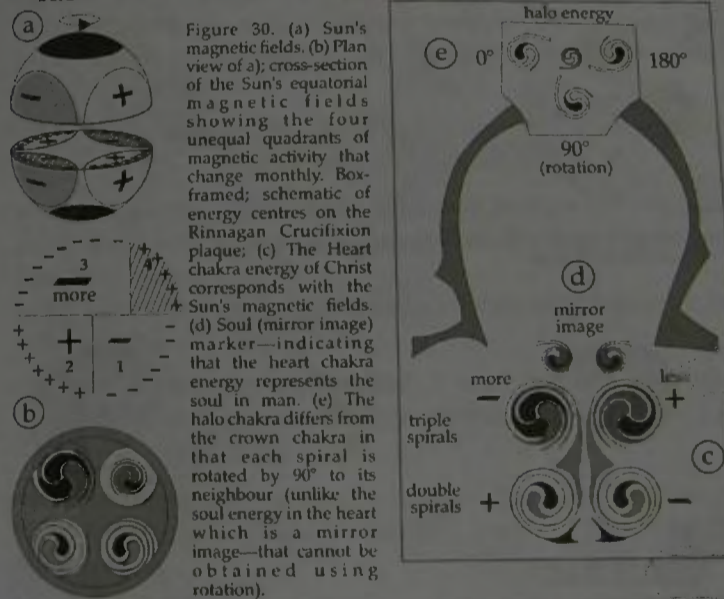
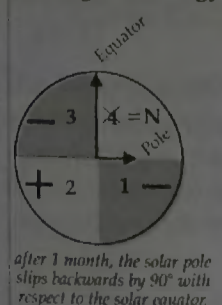

Figure 30. (a) Sun's magnetic fields. (b) Plan view of (a); cross-section of the Sun's equatorial magnetic fields showing the four unequal quadrants of magnetic activity that change monthly. Box-framed; schematic of energy centres on the Rinnagan Crucifixion plaque; (c) The Heart chakra energy of Christ corresponds with the Sun's magnetic fields. (d) Soul (mirror image) marker—indicating that the heart chakra energy represents the soul in man. (e) The halo chakra differs from the crown chakra in that each spiral is rotated by 90° to its neighbour (unlike the soul energy in the heart which is a mirror image—that cannot be obtained using rotation).

The Celts and Sun-sign Astrology



Monthly equatorial field sector disturbance caused by poles	Radiation pattern sequence—Neutralised by poles	Month	Element	Astrologic Sign
1234	123N	1	Fire	Aries
1234	12N4	2	Earth	Taurus
1234	1N34	3	Air	Gemini
1234	N234	4	Water	Cancer
1234	123N	5	Fire	Leo
1234	12N4	6	Earth	Virgo
1234	1N34	7	Air	Libra
1234	N234	8	Water	Scorpio
1234	123N	9	Fire	Sagittarius
1234	12N4	10	Earth	Capricorn
1234	1N34	11	Air	Aquarius
1234	N234	12	Water	Pisces

Figure 31. The equatorial region of the Sun spins every 26 days. The polar magnetic caps spin once every 37 days. The Earth orbits the Sun every 365.25 days. This interaction causes neutralisation of a different equatorial field sector every month. The resulting solar wind radiation sequence travels to Earth and is trapped in the Van Allen radiation belts causing the Earth's magnetic field to vary at ground level (figure 8). The magnetic modulations affect the production of Oestrogen and Progesterone in females regulating the menstrual cycle and causing genetic mutations in early impregnated ovum—by rearranging sections of DNA—producing 12 different personality types throughout each year, which is why the ancients worshipped the Sun as the God of Fertility and the God of [Sun-sign] Astrology.

highlight the difference between soul energy and godly energy; soul energy is godly energy (solar energy) which is attached to the heart of man whereas halo energy is pure godly energy, light.

The spiral, or whorl, is a central feature in Celtic art, meaning that the Celts were preoccupied with purification of the soul—the conversion of soul energy to halo energy [the conversion of 666 to 999], the super-science of the Sun, and the higher orders of spirituality.

The re-distribution of energy (figure 30b) can be analysed more simply, as in figure 31: here the reduced quadrant is considered 'neutralised' (N) each month. This is to say that an observer on Earth sees only three of the four quadrants in any one month (30.4375 days). The radiation of solar particles (positive and negative charges) leads to twelve different sequences of magnetic modulations of the Earth's magnetic field, resulting in twelve types of genetic mutations in early impregnated ovum and the consequential development of twelve different personality types each year (Sun-sign astrology). In addition, the radiation patterns are detected by the human brain causing varia-

Monthly equatorial field sector disturbance caused by poles	Radiation pattern sequence: neutralised by poles	Month	Element	Astrological Sign
1234	123N	1	Fire	Aries
1234	12N4	2	Earth	Taurus
1234	1N34	3	Air	Gemini
1234	N234	4	Water	Cancer
1234	123N	5	Fire	Leo
1234	12N4	6	Earth	Virgo
1234	1N34	7	Air	Libra
1234	N234	8	Water	Scorpio
1234	123N	9	Fire	Sagittarius
1234	12N4	10	Earth	Capricorn
1234	1N34	11	Air	Aquarius
1234	N234	12	Water	Pisces

Figure 31. The equatorial region of the Sun spins every 26 days. The polar magnetic caps spin once every 37 days. The Earth orbits the Sun every 365.25 days. This interaction causes neutralisation of a different equatorial field sector every month. The resulting solar wind radiation sequence travels to Earth and is trapped in the Van Allen radiation belts, causing the Earth's magnetic field to vary at ground level (figure 8). The magnetic modulations affect the production of oestrogen and progesterone in females, regulating the menstrual cycle and causing genetic mutations in early impregnated ovum—by rearranging sections of DNA—producing twelve different personality types throughout each year, which is why the ancients worshipped the Sun as the god of fertility and the god of [Sun-sign] Astrology.

tions in levels of the timing hormone melatonin and variations in the production of the fertility hormones oestrogen and progesterone, and the consequential regulation of menstruation and fertility in females—which is why the ancients worshipped the Sun as the god of astrology and the god of fertility.

The four-part heart spiral was represented by the Hallstatt Celts as the reverse swastika (figure 32ai). The tri-part halo energy spiral arrangement refers to the solar wind after equatorial field sector neutralisation. Those who increase their own soul voltage during their lifetime on Earth go to Heaven. The tri-part spiral was depicted by

The Secrets of the Celtic Spirals

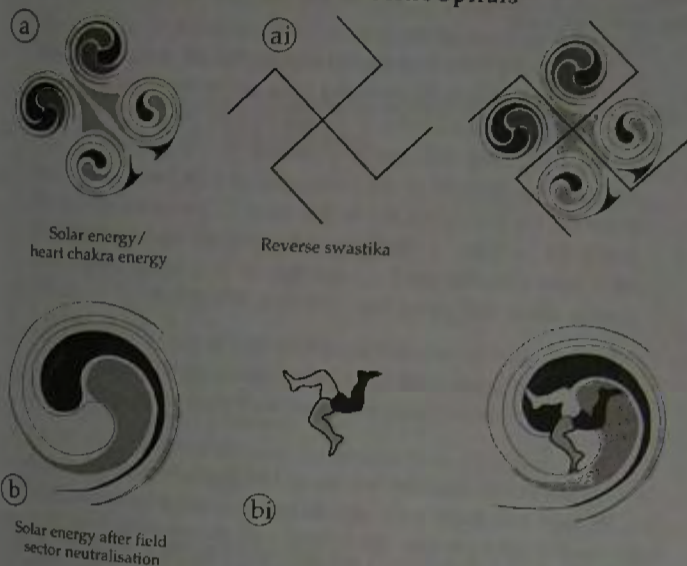

Figure 32. (a) Solar equatorial magnetic energy fields. (ai) Reverse swastika of the Hallstatt Celts depicting the solar radiation pattern, as seen from Venus, before field sector neutralisation caused by interaction with the polar fields. (b) Solar radiation pattern from the solar wind, as seen from Venus after field sector neutralisation caused by interaction with the polar fields. (bi) The Celtic symbol for Man, from the (Celtic) Isle of Man (a Dependency of the United Kingdom).

The Secrets of the Celtic Spirals

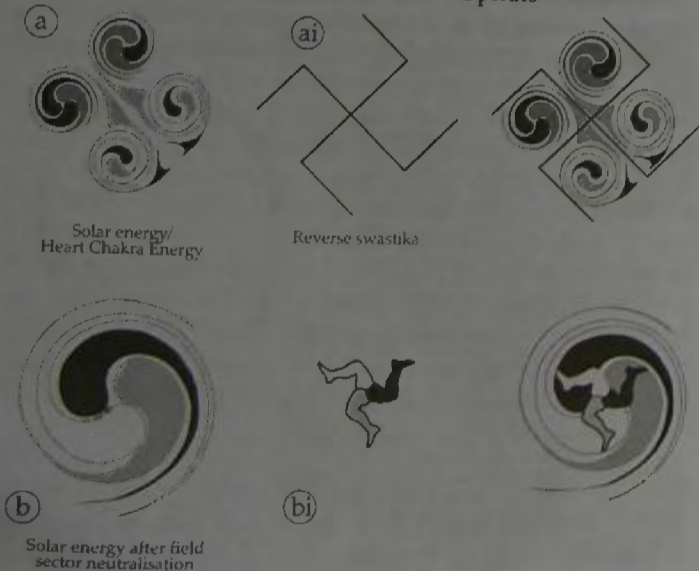

Figure 32. (a) Solar equatorial magnetic energy fields. (ai) Reverse swastika of the Hallstatt Celts depicting the solar radiation pattern, as seen from Venus, before field sector neutralisation caused by interaction with the polar fields. (b) Solar radiation pattern from the solar wind, as seen from Venus after field sector neutralisation caused by interaction with the polar fields. (bi) The Celtic symbol for Man, from the (Celtic) Isle of Man (a Dependency of the United Kingdom).

shake and became as dead men...and the angel said unto Mary...fear not ye: for I know that ye seek Jesus which was crucified. He is not here for he has risen...come see the place where the Lord lay...And go quickly and tell the Disciples that he is risen from the dead...and behold he goes before ye into Galilee, there shall ye see him. (Matthew XXVII 1-8).

Mary ran quickly towards Jerusalem and, as the angel had foretold, met the resurrected Jesus (who said): 'be not afraid, go tell my brethren that they go into Galilee, and there they shall see me.' (Matthew CCVII.

describe how he met with his Disciples. John XX. 25.

says that there were two meetings around this time, the first with 10 Disciples present, the second with eleven, including Thomas who had missed the first and doubted what they had told him, hence the expression 'doubting Thomas'.

Jesus told them all to 'go ye into the world and preach the Gospel to every creature...he that believes will be saved (Mark XVI, 15).

John XXI, 14 mentions a third meeting between Jesus and the Disciples; the third time that Jesus showed himself to his Disciples after he had risen from the dead.

The Book Acts of the Apostles says that Jesus remained on Earth for forty days following the resurrection:

...the Apostles whom he had chosen...To whom also he showed himself alive after his passion by many infallible proofs, being seen of them forty days...(Acts I, 2-3).

Acts then records how the Disciples gathered together and prayed to God, asking for guidance in selecting a replacement for the dead Judas Iscariot, saying:

...[who shall take part]... In this ministry and Apostleship, from which Judas by transgression fell?...and they gave forth lots; and the lot fell upon Mathius, and he was numbered with the eleven Apostles. (Acts, 24-26).

The names of the Apostles, given in the Acts of the Apostles thus differ to other accounts in the Gospels;

- Peter
- James
- John
- Andrew
- Philip
- Bartholomew
- Matthew
- Thomas
- James (the son of Alphaeus)
- Judas, the brother of James [Thaddaeus; Jude Thaddeus]

the Celts as the three-legged symbol of Man (figure 32bi), the national emblem of the Celtic people, the Manx, of the Isle of Man.³⁵

After the Crucifixion

Following the Crucifixion, the body of Jesus was laid to rest in the tomb previously prepared for Joseph of Arimathea. Pontius Pilate, fearful of claims of martyrdom should the body be taken, arranged for the opening of the sepulchre to be blocked by a large rock and for two Roman Centurions to stand guard.

The next day Mary Magdalene—who some say was the closest of anyone to Jesus—visited the tomb. The Centurions were dead. The large rock that had blocked the tomb had been rolled away exposing the open entrance:

... And behold there was a great earthquake for the angel of the Lord descended from Heaven and came and rolled back the stone from the door and sat upon it ... and for fear of him the keepers [guards] did shake and became as dead men ... and the angel said unto Mary ... fear not ye: for I know that ye seek Jesus which was crucified. He is not here for he has risen ... come see the place where the Lord lay ... And go quickly and tell the Disciples that he is risen from the dead ... and behold he goes before ye into Galilee, there shall ye see him. (*Matthew XXVII 1-8*)

Mary ran quickly towards Jerusalem and, as the angel had foretold, met the resurrected Jesus; be not afraid, go tell my bretheren that they go into Galilee, and there they shall see me. (*Matthew CCVII, 10*)

Verse 16 goes on to describe how he met with his eleven Disciples. John XX, 25, says that there were two meetings around this time, the first with ten Disciples present, the second with eleven, including Thomas, who had missed the first and doubted what they had told him, hence the expression 'doubting Thomas':

Jesus told them all to 'go ye into the world and preach the Gospel to every creature ... he that believes will be saved. (*Mark XVI, 15*)

John XXI, 14 mentions a third meeting between Jesus and the Disciples³⁶

84

the third time that Jesus showed himself to his Disciples after he had risen from the dead.

The book Acts of the Apostles says that Jesus remained on Earth for forty days following the resurrection:

... the Apostles whom he had chosen ... To whom also he showed himself alive after his passion by many infallible proofs, being seen of them forty days ... (*Acts I, 2-3*)

Acts then records how the Disciples gathered together and prayed to God, asking for guidance in selecting a replacement for the dead Judas Iscariot, saying:

... [who shall take part] ... in this ministry and Apostleship, from which Judas by transgression fell? ... and they gave forth lots; and the lot fell upon Mathius, and he was numbered with the eleven Apostles. (*Acts 24-26*)

The names of the Apostles, given in the Acts of the Apostles, thus differ from other accounts in the Gospels:

- Peter
- James
- John
- Andrew
- Philip
- Bartholomew
- Matthew
- Thomas
- James (the son of Alphaeus)
- Judas, the brother of James [Thaddaeus; Jude Thaddeus]
- Simon Zelotes (the Zealot)
- Mathius, who replaced Judas Iscariot

This appears to be the last time that the Disciples met with the resurrected Jesus. But Acts goes on to say that the Holy Spirit visited them on the day of Pentecost.³⁶ There, the tongues of the Apostles, before the gathered multitude, were confounded, allowing them to speak in many languages and thereby spread the teachings of Christ throughout the world.

- Simon Zelotes (the Zealot)
- **Mathius**, who replaced Judas Iscariot

This appears to be the last time that the Disciples met with the resurrected Jesus. But Acts goes on to say that the Holy Spirit visited them on the day of Pentecost³⁶. There, the tongues of the Apostles, before the gathered multitude, were confounded, allowing them to speak in many languages and thereby spread the teachings of Christ throughout the world.

The Gospel of Mark, the first of the four to appear, was set down by Mark in around AD 70. The Gospel of Matthew appeared shortly after written in Greek and then The Gospel of Luke (AD 80 or 90), who also compiled the Acts of the Apostles. The Gospel according to John was the last to appear, according to fragments of a papyrus discovered in around AD 100 that contains part of the 18th Chapter.

The Appearance of St Paul

In the years immediately following the Crucifixion 60 others were called to the Apostleship including St Paul—the convert Saul who was born in Tarsus (Turkey) and obtained Roman Citizenship. In the early days he was involved in stoning the Christians, but after experiencing a vision of Jesus (on the road to Damascus) he was transformed into a Christian.

After the Crucifixion and ascension of Christ, Paul travelled widely around the eastern Mediterranean making at least 14 missionary journeys to: Cyprus, Attalia, Tarsus, Iconium, Antioch, Asia Minor, Troy, Philippi, Thessaly [near Macedonia], Athens, Corinth and Crete before returning to Jerusalem. There, the Jews accused Paul of blasphemy leading to his arrest by the Romans who imprisoned him (*Acts XXV*). Paul was then shipped to Rome (*Acts XXVII*) in AD 64 where he may have been acquitted and released before being re-arrested and executed at [modern-day] Tre Fontane in Rome in AD 67.

The life and times of Paul were set down in letters written by him from around AD 51: The Epistle of Paul the Apostle to the Romans [abb. *Romans*], The First Epistle of Paul the Apostle to the Corinthians [abb. *Corinthians I*], The Second Epistle of Paul the Apostle to the Corinthians [abb. *Corinthians II*], The Epistle of Paul the Apostle to the Galatians [abb. *Galatians*], The First

Epistle of Paul the Apostle to the Ephesians [abb. *Ephesians*], The Epistle of Paul the Apostle to the Philippians [abb. *Philippians*], The Epistle of Paul the Apostle to the Colossians [abb. *Colossians*], The First Epistle of Paul the Apostle to the Thessalonians [abb. *Thessalonians I*], The Second Epistle of Paul the Apostle to the Thessalonians [abb. *Thessalonians II*] and The Epistle of Paul the Apostle to Philemon [abb. *Philemon*]. The Epistles of Paul to the Hebrews, Titus and Timothy are not ascribed to him but are believed to have been written after his death. All of the Epistles were written in Greek.

Other Epistles in the New Testament, the authorship of which is uncertain, appeared in the 50 years that followed; The General Epistle of James, Peter (I and II), John (I, II and III) and Jude.

Revelation, the last book of the New Testament, was written by St John on the Greek Island of Patmos where he had been banished by the Emperor Domitian. It tells of a Revelation by St John. Its meaning is unknown and allegorical containing visions, nightmares of Heaven and Hell, prophecies about the end of the World and the final day of Judgment. It contains the enigmatic numbers of 666 and 144,000 that appear in the treasures of all of the other Supergods (described earlier in Chapter I) and ends with Jesus saying 'I am the bright and morning star' and warns no one to change, add, or take away, any word of what has been written.

Collation of the New Testament

By now the Gospels, Epistles, and Revelations were lost in a canonical free-for-all of forgeries, wishful thinking and speculation. A standard text was sorely needed, one that had sorted the wheat from the chaff; an arrangement of the holy works in a single collection along the lines of the Old Testament.

The delay was due to difficulty in several areas, among them; the selection of material that should be included and uncertainty in regard to who or what authority was qualified to judge.

In around AD 150 a wealthy businessman named Marcion was having his own say in his local town of Sinope on the Black Sea. He believed that God had sent his son Jesus to Earth to deliver mankind from the God of the Jews, Jehova, and decided that the true God was not the evil Jehova but the all new, all loving, all forgiving God proclaimed by Jesus.

The Gospel of Mark, the first of the four to appear, was set down by Mark in around AD 70. The Gospel of Matthew appeared shortly after, written in Greek, and then the Gospel of Luke (AD 80 or 90), who also compiled the Acts of the Apostles. The Gospel according to John was the last to appear, according to fragments of a papyrus discovered in around AD 100 that contains part of the eighteenth chapter.

The Appearance of St. Paul

In the years immediately following the Crucifixion, sixty others were called to the Apostleship including St. Paul—the convert Saul who was born in Tarsus (Turkey) and obtained Roman citizenship. In the early days he was involved in stoning the Christians, but after experiencing a vision of Jesus (on the road to Damascus) he was transformed into a Christian.

After the Crucifixion and ascension of Christ Paul travelled widely around the eastern Mediterranean making at least fourteen missionary journeys to: Cyprus, Attalia, Tarsus, Iconium, Antioch, Asia Minor, Troy, Philippi, Thessaly [near Macedonia], Athens, Corinth and Crete before returning to Jerusalem. There, the Jews accused Paul of blasphemy leading to his arrest by the Romans who imprisoned him (Acts XXV). Paul was then shipped to Rome (Acts XXVII) in AD 64 where he may have been acquitted and released before being re-arrested and executed at [modern-day] Tre Fontane in Rome in AD 67.

The life and times of Paul were set down in letters written by him from around AD 51: the Epistle of Paul the Apostle to the Romans [abb. Romans], the First Epistle of Paul the Apostle to the Corinthians [abb. Corinthians I], the Second Epistle of Paul the Apostle to the Corinthians [abb. Corinthians II], the Epistle of Paul the Apostle to the Galatians [abb. Galatians], the First Epistle of Paul the Apostle to the Ephesians [abb. Ephesians], the Epistle of Paul the Apostle to the Philippians [abb. Philippians], the Epistle of Paul the Apostle to the Colossians [abb. Colossians], the First Epistle of Paul the Apostle to the Thessalonians [abb. Thessalonians I], the Second Epistle of Paul the Apostle to the Thessalonians [abb. Thessalonians II] and the Epistle of Paul the Apostle to Philemon [abb. Philemon]. The Epistles of Paul

THE CELTIC CHRONICLES

He thus sought a complete break from the past from the Old Testament and from the history and beliefs of the Jew. His father, the local Bishop, was so unimpressed that he banished his *heretic* son from the town. Undeterred, Marcion decided to go to Rome and donate his fortune—to the Church in the hope that he could put together a New Testament—according to Marcion, that might be accepted by the emerging Christian Church.

He began by throwing out the Gospels of Matthew, Mark and John, preferring that of Luke. He decided to exclude the Jews and anything Jewish, after all, he believed, that they had brought about the trial and consequent Crucifixion of Jesus. Part I of his Canon thus comprised of the Gospel of Luke and Part II of just 10 of St Paul's Epistles. Nothing else qualified for inclusion as far as he was concerned. Then he revised both parts, removing any reference to the Jew.

Christians, unimpressed with Marcion's version of events, decided to ignore him and the first attempt at compiling a 'New Testament' was left to gather dust.

The first attempt at consolidation came from a Christian martyr named Justin who died in Rome in AD 165. He issued a critique on what might be true and what might be false in the teachings of the day and in so doing became a forefather of what might in future be included in any New Testament.

In the eighteenth-century some fragments of an early (c. AD 200) manuscript named the 'Muratorian Fragments' (after the name of the librarian who discovered them) surfaced in the library of Milan. They contain a dissertation, in poor Latin, on the efficacy of Christian literature: the Gospels are classified as genuine as are the Acts, Revelation, the Epistles of Paul, John and Jude, but not Hebrews, Peter and James or John III. The unknown author writes in extremely poor and primitive Latin that often either uneducated or that the manuscript was poorly transcribed.

In the second century Irenaeus, the Bishop of Gallia, quoted from the four Gospels, the Epistles of Paul the Acts, Revelation, the Epistles of Peter I and II.

Around the same time a Syrian Christian named Tatian, attempted to synthesize the four Gospels into one story written in Modern Greek for

to the Hebrews, Titus and Timothy are not ascribed to him but are believed to have been written after his death. All of the Epistles were written in Greek.

Other Epistles in the New Testament, the authorship of which is uncertain, appeared in the fifty years that followed: the General Epistle of James, Peter (I and II), John (I, II and III) and Jude.

Revelation, the last book of the New Testament, was written by St John on the Greek island of Patmos where he had been banished by the emperor Domitian. It tells of a Revelation to St. John. Its meaning is unknown and allegorical containing visions, nightmares of Heaven and Hell, prophecies about the end of the World and the final day of Judgement. It contains the enigmatic numbers of 666 and 144,000 that appear in the treasures of all of the other Supergods (described in chapter 1) and ends with Jesus saying 'I am the bright and morning star' and warns no one to change, add, or take away any word of what has been written.

Collation of the New Testament

By now the Gospels, Epistles, and Revelations were lost in a canonical free-for-all of forgeries, wishful thinking and speculation. A standard text was sorely needed, one that had sorted the wheat from the chaff: an arrangement of the holy works in a single collection along the lines of the Old Testament.

The delay was due to difficulty in several areas, among them: the selection of material that should be included and uncertainty in regard to who or what authority was qualified to judge.

In around AD 150 a wealthy businessman named Marcion was having his own say in his local town of Sinope on the Black Sea. He believed that God had sent his son Jesus to Earth to deliver mankind from the God of the Jews, Jehovah, and decided that the true God was not the evil Jehovah but the all new, all loving, all forgiving God proclaimed by Jesus. He thus sought a complete break from the past, from the Old Testament and from the history and beliefs of the Jews. His father, the local bishop, was so unimpressed that he banished his *heretic* son from the town. Undeterred, Marcion decided to go to Rome and donate his fortune to the Church in the hope that he could put together

the layman. His version found favour for the next two hundred years until at least AD 360 when the scholar Ephraim commented upon it. But in AD 450 the priest of the Syrian church, Theodore of Antioch, declared it invalid in favour of four separate Gospels.

The Gospel of Truth, one of the Gnostic writings found at Nag Hamadi in 1947, suggests that a New Testament along the lines of the one of today existed in around AD 150. Gnosticism—divine knowledge based on a combination of Christianity, Greek philosophy, Hinduism and Buddhism—was an early rival of orthodox Christianity.

In AD 254, in Alexandria, the early Church Father Origen reconfigured writings into a New Testament in Greek which was later augmented by the Bishop of Caesara (in Palestine), Eusebius Pamphili, in AD 314.

Persecution of Christians prevailed from the date of the Crucifixion until the reign of Constantine the Great (AD 285–337) in Rome. In AD 306 he succeeded his father as joint Roman Emperor, in York, England. In AD 312, during a victorious battle outside Rome, he saw a vision of the cross of Christ on the face of the Sun which inspired his conversion to Christianity. A year later he issued his 'Edict of Tolerance', extending religious tolerance to all faiths and in AD 324 became the first Christian Roman Emperor to rule the whole of the Roman Empire.

The developing Church in Rome modelled itself on the structure of the Empire. The dioceses were structured along the lines of Roman administration; city based Bishops met in *Synod* in the capitals. Roman Bishops shared power with those of Constantinople and Alexandria, and Antioch and Jerusalem in the East. At the same time a significant number of Christians chose a life of renunciation by retreating into monasteries established under the monks Pachomius (AD 290–346) and Basil (c. AD 330–377) in the East and Benedict (c. AD 480–550) in the West.

The Christian community in Britain was growing in numbers steadily and martyrs began to appear. St Alban, a prominent Roman citizen of Verulamium (present-day St Alban) was the first English martyr to be executed—beheaded on a hill 30 miles north of London where the modern-day church of St Alban now stands. The British Church must have been organised into dioceses by at least AD 314 when the Bishops of York, London and Lincoln are known to have attended the Council of Arles in AD 314. Early Churches were established in Silchester in AD 360

The Gospel of Mark, the first of the four to appear, was set down by Mark in around AD 70. The Gospel of Matthew appeared shortly after, written in Greek, and then the Gospel of Luke (AD 80 or 90), who also compiled the Acts of the Apostles. The Gospel according to John was the last to appear, according to fragments of a papyrus discovered in around AD 100 that contains part of the eighteenth chapter.

The Appearance of St. Paul

In the years immediately following the Crucifixion, sixty others were called to the Apostleship including St. Paul—the convert Saul who was born in Tarsus (Turkey) and obtained Roman citizenship. In the early days he was involved in stoning the Christians, but after experiencing a vision of Jesus (on the road to Damascus) he was transformed into a Christian.

After the Crucifixion and ascension of Christ Paul travelled widely around the eastern Mediterranean making at least fourteen missionary journeys to: Cyprus, Attalia, Tarsus, Iconium, Antioch, Asia Minor, Troy, Philippi, Thessaly [near Macedonia], Athens, Corinth and Crete before returning to Jerusalem. There, the Jews accused Paul of blasphemy leading to his arrest by the Romans who imprisoned him (Acts XXV). Paul was then shipped to Rome (Acts XXVII) in AD 64 where he may have been acquitted and released before being re-arrested and executed at [modern-day] Tre Fontane in Rome in AD 67.

The life and times of Paul were set down in letters written by him from around AD 51: the Epistle of Paul the Apostle to the Romans [abb. Romans], the First Epistle of Paul the Apostle to the Corinthians [abb. Corinthians I], the Second Epistle of Paul the Apostle to the Corinthians [abb. Corinthians II], the Epistle of Paul the Apostle to the Galatians [abb. Galatians], the First Epistle of Paul the Apostle to the Ephesians [abb. Ephesians], the Epistle of Paul the Apostle to the Philippians [abb. Philippians], the Epistle of Paul the Apostle to the Colossians [abb. Colossians], the First Epistle of Paul the Apostle to the Thessalonians [abb. Thessalonians I], the Second Epistle of Paul the Apostle to the Thessalonians [abb. Thessalonians II] and the Epistle of Paul the Apostle to Philemon [abb. Philemon]. The Epistles of Paul

to the Hebrews, Titus and Timothy are not ascribed to him but are believed to have been written after his death. All of the Epistles were written in Greek.

Other Epistles in the New Testament, the authorship of which is uncertain, appeared in the fifty years that followed: the General Epistle of James, Peter (I and II), John (I, II and III) and Jude.

Revelation, the last book of the New Testament, was written by St John on the Greek island of Patmos where he had been banished by the emperor Domitian. It tells of a Revelation to St. John. Its meaning is unknown and allegorical containing visions, nightmares of Heaven and Hell, prophecies about the end of the World and the final day of Judgement. It contains the enigmatic numbers of 666 and 144,000 that appear in the treasures of all of the other Supergods (described in chapter 1) and ends with Jesus saying 'I am the bright and morning star' and warns no one to change, add, or take away any word of what has been written.

Collation of the New Testament

By now the Gospels, Epistles, and Revelations were lost in a canonical free-for-all of forgeries, wishful thinking and speculation. A standard text was sorely needed, one that had sorted the wheat from the chaff: an arrangement of the holy works in a single collection along the lines of the Old Testament.

The delay was due to difficulty in several areas, among them: the selection of material that should be included and uncertainty in regard to who or what authority was qualified to judge.

In around AD 150 a wealthy businessman named Marcion was having his own say in his local town of Sinope on the Black Sea. He believed that God had sent his son Jesus to Earth to deliver mankind from the God of the Jews, Jehovah, and decided that the true God was not the evil Jehovah but the all new, all loving, all forgiving God proclaimed by Jesus. He thus sought a complete break from the past, from the Old Testament and from the history and beliefs of the Jews. His father, the local bishop, was so unimpressed that he banished his heretic son from the town. Undeterred, Marcion decided to go to Rome and donate his fortune to the Church in the hope that he could put together

He thus sought a complete break from the past from the Old Testament and from the history and beliefs of the Jew. His father, the local Bishop, was so unimpressed that he banished his heretic son from the town. Undeterred, Marcion decided to go to Rome and donate his fortune to the Church in the hope that he could put together a New Testament—according to Marcion, that might be accepted by the emerging Christian Church.

He began by throwing out the Gospels of *Matthew*, *Mark* and *John*, preferring that of *Luke*. He decided to exclude the Jews and anything Jewish, after all, he believed, that they had brought about the trial and consequent Crucifixion of Jesus. Part I of his Canon thus comprised of the *Gospel of Luke* and Part II of just 10 of St Paul's Epistles. Nothing else qualified for inclusion as far as he was concerned. Then he revised both parts, removing any reference to the Jew.

Christians, unimpressed with Marcion's version of events, decided to ignore him and the first attempt at compiling a 'New Testament' was left to gather dust.

The first attempt at consolidation came from a Christian martyr named Justin who died in Rome in AD 165. He issued a critique on what might be true and what might be false in the teachings of the day and in so doing became a forefather of what might in future be included in any New Testament.

In the eighteenth-century some fragments of an early (c. AD 200) manuscript named the 'Muratorian Fragments' (after the name of the librarian who discovered them) surfaced in the library of Milan. They contain a dissertation, in poor Latin, on the efficacy of Christian literature; the Gospels are classified as genuine as are the *Acts*, *Revelation*, the *Epistles of Paul*, *John* and *Jude*, but not *Hebrews*, *Peter* and *James* or *John III*. The unknown author writes in extremely poor and primitive Latin that often degenerates, with many grammatical mistakes; suggesting that he was either uneducated or that the manuscript was poorly transcribed.

In the second century Irenaeus, the Bishop of Gallia, quoted from the four Gospels, the *Epistles of Paul*, the *Acts*, *Revelation*, the *Epistles of Peter I* and *John I* and *II*.

Around the same time a Syrian Christian named Tatian, attempted to synthesise the four Gospels into one story written in Modern Greek for

the layman. His version found favour for the next two hundred years until at least AD 360 when the scholar Ephraim commented upon it. But in AD 450 the priest of the Syrian church, Theodore of Antioch, declared it invalid in favour of four separate Gospels.

The Gospel of Truth, one of the Gnostic writings found at Nag Hamadi in 1947, suggests that a New Testament along the lines of the one of today existed in around AD 150. Gnosticism—divine knowledge based on a combination of Christianity, Greek philosophy, Hinduism and Buddhism—was an early rival of orthodox Christianity.

In AD 254, in Alexandria, the early Church Father Origen reconfigured writings into a New Testament in Greek which was later augmented by the Bishop of Caesara (in Palestine), Eusebius Pamphilli, in AD 314.

Persecution of Christians prevailed from the date of the Crucifixion until the reign of Constantine the Great (AD 285-337) in Rome. In AD 306 he succeeded his father as joint Roman Emperor, in York, England. In AD 312, during a victorious battle outside Rome, he saw a vision of the cross-of-Christ on the face of the Sun which inspired his conversion to Christianity. A year later he issued his 'Edict of Tolerance, extending religious tolerance to all faiths and in AD 324 became the first Christian Roman Emperor to rule the whole of the Roman Empire.

The developing Church in Rome modelled itself on the structure of the Empire. The dioceses were structured along the lines of Roman administration; city based Bishops met in *Synod* in the capitals. Roman Bishops shared power with those of Constantinople and Alexandria, and Antioch and Jerusalem in the East. At the same time a significant number of Christians chose a life of renunciation by retreating into monasteries established under the monks Pachomius (AD 290-346) and Basil (c. AD 330-377) in the East and Benedict (c. AD 480-550) in the West.

The Christian community in Britain was growing in numbers steadily and martyrs began to appear. St Alban, a prominent Roman citizen of Verulamium (present-day St Alban) was the first English martyr to be executed—beheaded on a hill 30 miles north of London where the modern-day church of St Alban now stands. The British Church must have been organised into dioceses by at least AD 314 when the Bishops of York, London and Lincoln are known to have attended the Council of Arles in AD 314. Early Churches were established in Silchester in AD 360

a New Testament—according to Marcion—that might be accepted by the emerging Christian Church.

He began by throwing out the Gospels of Matthew, Mark and John, preferring that of Luke. He decided to exclude the Jews and anything Jewish; after all, he believed that they had brought about the trial and consequent Crucifixion of Jesus. Part I of his Canon thus consisted of the Gospel of Luke and Part II of just ten of St. Paul's Epistles. Nothing else qualified for inclusion as far as he was concerned. Then he revised both parts, removing any reference to the Jews.

Christians, unimpressed with Marcion's version of events, decided to ignore him and the first attempt at compiling a 'New Testament' was left to gather dust.

The second attempt at consolidation came from a Christian martyr named Justin who died in Rome in AD 165. He issued a critique on what might be true and what might be false in the teachings of the day and in so doing became a forefather of what might in future be included in any New Testament.

In the eighteenth century some fragments of an early (c. AD 200) manuscript named the 'Muratorian Fragments' (after the name of the librarian who discovered them) surfaced in the library of Milan. They contain a dissertation, in poor Latin, on the efficacy of Christian literature; the Gospels are classified as genuine as are the Acts, Revelation, the Epistles of Paul, John and Jude, but not Hebrews, Peter and James or John III. The unknown author writes in extremely poor and primitive Latin that often degenerates into slang containing grammatical mistakes, suggesting that he was either uneducated or that the manuscript was poorly transcribed.

In the second century Irenaeus, the bishop of Gallia, quoted from the four Gospels, the Epistles of Paul, the Acts, Revelation, the Epistles of Peter I and John I and II.

Around the same time a Syrian Christian named Tatian attempted to synthesise the four Gospels into one story written in Modern Greek for the layman. His version found favour for the next 200 years until at least AD 360 when the scholar Ephraim commented upon it. But in AD 450 the priest of the Syrian church, Theodore of Antioch, declared it invalid in favour of four separate Gospels.

The Gospel of Truth, one of the Gnostic writings found at Nag

Hammadi in 1947, suggests that a New Testament along the lines of the one of today existed in around AD 150. Gnosticism—divine knowledge based on a combination of Christianity, Greek philosophy, Hinduism and Buddhism—was an early rival of orthodox Christianity.

In AD 254, in Alexandria, the early Church Father Origen reconfigured writings into a New Testament in Greek which was later augmented by the bishop of Caesarea (in Palestine), Eusebius Pamphili, in AD 314.

Persecution of Christians prevailed from the date of the Crucifixion until the reign of Constantine the Great (AD 285–337) in Rome. In AD 306 he succeeded his father as joint Roman emperor, in York, England. In AD 312, during a victorious battle outside Rome, he saw a vision of the cross-of-Christ on the face of the Sun which inspired his conversion to Christianity. A year later he issued his 'Edict of Tolerance', extending religious tolerance to all faiths and in AD 324 became the first Christian Roman emperor to rule the whole of the Roman Empire.

The developing Church in Rome modelled itself on the structure of the empire. The dioceses were structured along the lines of Roman administration; city-based bishops met in Synod in the capitals. Roman bishops shared power with those of Constantinople and Alexandria, and Antioch and Jerusalem in the East. At the same time a significant number of Christians chose a life of renunciation by retreating into monasteries established under the monks Pachomius (AD 290–346) and Basil (c. AD 330–377) in the east and Benedict (c. AD 480–550) in the west.

The Christian community in Britain was steadily growing in numbers and martyrs began to appear. St. Alban, a prominent Roman citizen of Verulamium (present-day St. Alban), was the first English martyr to be executed—beheaded on a hill thirty miles north of London where the modern-day church of St. Alban now stands. The British Church must have been organised into dioceses by at least AD 314 when the bishops of York, London and Lincoln are known to have attended the Council of Arles in AD 314. Early churches were established in Silchester in AD 360 and Caerwent.

The first Ecumenical Council to represent the whole of the Christian Church met at Nicaea in AD 325. In AD 367, Athanasius, bishop of Alexandria, included Revelation into the New Testament and declared,

and Caerwent.

The first Ecumenical Council to represent the whole of the Christian Church met at Nicaea in AD 325. In AD 367 Athanasius, Bishop of Alexandria, included *Revelation* into the New Testament and declared, in his Festive Letter of Anasthasius, the New Testament to be fixed and unalterable. Other Ecumenical Councils followed in Constantinople (AD 381), Ephesus (AD 431) and Chalcedon (AD 451).

The development of the Latin version of the New Testament, preferred by Rome, differed from the Greek version. In Italy the early Church fathers Cyprian, Hilarius and Ambrose preferred a version along the lines of the Muratorian fragments until in 382 Pope Damasus commissioned the Christian scholar Jerome to make a new version of the Bible in Latin. At first he worked from Rome before moving to a monastery in Bethlehem where he translated the Old Testament, direct from the Hebrew, and the New Testament from the Greek version. His version, the *Vulgate* (the book of the people) became the most popular Latin version of the Bible from the seventh-century but was not adopted as the official Catholic Bible until 1546 by the Council of Trent.

In Syria Tatian's integrated Gospels were favoured until the fifth-century when Syrian Bishops developed the standard Bible the *Peshitto* which was brought into line with the Greek and Latin versions in the sixth and seventh centuries. The earliest known version of the New Testament comes from an early *Peshitto* manuscript precisely dated as being written in AD 464.

Joseph of Aramathea who had acquired and hidden the Holy Grail used by Christ at the Last Supper was imprisoned in Palestine. It is said that the holy powers of the Grail sustained him during his period of imprisonment. After his release, legend says that he sailed with Lazarus—who was raised from the dead by Jesus—Mary Magdelene and the Apostle Phillip, from Palestine to Marseille in France. Mary and Lazarus stayed at Marseille while Joseph, the Grail and 12 followers of Christ continued on the voyage to Glastonbury. Legend says that on landfall Joseph climbed a local hill and thrust his rosewood staff, grown from Christ's holy crown of thorns, into the ground where it miraculously took root on Wearyall Hill where, to this day, it blossoms every Christmas. In AD 60 Joseph purchased land on Glastonbury Hill upon which he built the

first wood and wattle Christian church named *Vetusta Ecclesia* where he was later buried together with the Holy Grail.

The recovery of the Grail became the great quest of the Knights of the Round Table. The Grail, so one version of the Arthurian story recalls³⁷, was handed over by Joseph to the knight Sir Galahad who 'took our Lord's body between his hands more than 300 years after Joseph's death, and then he died'.

Collapse of Roman Rule

In AD 330 the capital of the Roman empire was transferred to Byzantium—modern Istanbul—by Constantine the Great who renamed it Constantinople, the capital of the Byzantine Empire.

By the end of the fourth-century Rome came increasingly under attack from barbarians and as a result recalled troops from the outposts of empire. By AD 406 the Romans had gone from Britain leaving a power vacuum in their wake. England was overrun by barbarian Picts from Scotland and Celts from Ireland. A new Celtic leader named Vortigern (active AD 425–450) emerged from the Welsh border-lands to rally the English Celts and, under pressure, appealed for Roman help to repel the invaders. At first the Romans responded with troops but eventually, realising the futility of their contribution withdrew, leaving Vortigern to go it alone.

Vortigern met with the Council of British Kings who agreed to call-in mercenaries from Germany. The Angles, Saxons and Jutes sent three longboats full of fighters across the Channel in return for gold. According to the English historian Bede³⁸ the first consignment arrived in AD 449 led by the Saxon brothers Hengist and Horsa. At first the arrangement worked well. So much so that the daughter of Hengist was married to Vortigern who bequeathed to him the land of Kent. But Hengist wanted more and the treachery began; he arranged a banquet of 300 British Noblemen together with 300 Angles and Saxons who, on the orders of Hengist, drew their daggers and killed the British. It was known as the 'night of the long knives'. Much of south-east England was now in the hands of the Angles and Saxons who pushed what remained of Vortigern's men westwards. But many areas of England, to the west and south-west, remained free from Saxon control.

in his Festive Letter of Athanasius, the New Testament to be fixed and unalterable. Other ecumenical councils followed in Constantinople (AD 381), Ephesus (AD 431) and Chalcedon (AD 451).

The development of the Latin version of the New Testament, preferred by Rome, differed from the Greek version. In Italy the early Church Fathers Cyprian, Hilarius and Ambrose preferred a version along the lines of the Muratorian fragments until in 382 Pope Damasus commissioned the Christian scholar Jerome to make a new version of the Bible in Latin. At first he worked from Rome before moving to a monastery in Bethlehem where he translated the Old Testament, direct from the Hebrew, and the New Testament from the Greek version. His version, the Vulgate (the book of the people), became the most popular Latin version of the Bible from the seventh century but was not adopted as the official Catholic Bible until 1546 by the Council of Trent.

In Syria Tatian's integrated Gospels were favoured until the fifth century when Syrian bishops developed the standard Bible, the *Peshitto*, which was brought into line with the Greek and Latin versions in the sixth and seventh centuries. The earliest known version of the New Testament comes from an early *Peshitto* manuscript precisely dated as being written in AD 464.

Joseph of Arimathea who had acquired and hidden the Holy Grail used by Christ at the Last Supper was imprisoned in Palestine. It is said that the holy powers of the Grail sustained him during his period of imprisonment. After his release, legend says that he sailed with Lazarus—who was raised from the dead by Jesus—Mary Magdelene and the Apostle Philip, from Palestine to Marseilles in France. Mary and Lazarus stayed at Marseilles while Joseph, the Grail and twelve followers of Christ continued on the voyage to Glastonbury. Legend says that on landfall Joseph climbed a local hill and thrust his rosewood staff, grown from Christ's holy crown of thorns, into the ground where it miraculously took root on Wearyall Hill where, to this day, it blossoms every Christmas. In AD 60 Joseph purchased land on Glastonbury Hill upon which he built the first wood and wattle Christian church named *Vetusta Ecclesia* where he was later buried together with the Holy Grail.

The recovery of the Grail became the great quest of the Knights of the Round Table. The Grail, so one version of the Arthurian story

and Caerwent.

The first Ecumenical Council to represent the whole of the Christian Church met at Nicaea in AD 325. In AD 367 Athanasius, Bishop of Alexandria, included *Revelation* into the New Testament and declared, in his Festive Letter of Athanasius, the New Testament to be fixed and unalterable. Other Ecumenical Councils followed in Constantinople (AD 381), Ephesus (AD 431) and Chalcedon (AD 451).

The development of the Latin version of the New Testament, preferred by Rome, differed from the Greek version. In Italy the early Church fathers Cyprian, Hilarius and Ambrose preferred a version along the lines of the Muratorian fragments until in 382 Pope Damasus commissioned the Christian scholar Jerome to make a new version of the Bible in Latin. At first he worked from Rome before moving to a monastery in Bethlehem where he translated the Old Testament, direct from the Hebrew, and the New Testament from the Greek version. His version, the *Vulgate* (the book of the people) became the most popular Latin version of the Bible from the seventh-century but was not adopted as the official Catholic Bible until 1546 by the Council of Trent.

In Syria Tatian's integrated Gospels were favoured until the fifth-century when Syrian Bishops developed the standard Bible the *Peshitto* which was brought into line with the Greek and Latin versions in the sixth and seventh centuries. The earliest known version of the New Testament comes from an early *Peshitto* manuscript precisely dated as being written in AD 464.

Joseph of Aramathea who had acquired and hidden the Holy Grail used by Christ at the Last Supper was imprisoned in Palestine. It is said that the holy powers of the Grail sustained him during his period of imprisonment. After his release, legend says that he sailed with Lazarus—who was raised from the dead by Jesus—Mary Magdelene and the Apostle Phillip, from Palestine to Marseille in France. Mary and Lazarus stayed at Marseille while Joseph, the Grail and 12 followers of Christ continued on the voyage to Glastonbury. Legend says that on landfall Joseph climbed a local hill and thrust his rosewood staff, grown from Christ's holy crown of thorns, into the ground where it miraculously took root on Wearyall Hill where, to this day, it blossoms every Christmas. In AD 60 Joseph purchased land on Glastonbury Hill upon which he built the

recalls, was handed over by Joseph to the knight Sir Galahad who 'took our Lord's body between his hands more than 300 years after Joseph's death, and then he died'.³⁷

Collapse of Roman Rule

In AD 330 the capital of the Roman Empire was transferred to Byzantium—modern Istanbul—by Constantine the Great who renamed it Constantinople, the capital of the Byzantine Empire.

By the end of the fourth century Rome came increasingly under attack from barbarians and as a result recalled troops from the outposts of the empire. By 406 the Romans had gone from Britain leaving a power vacuum in their wake. England was overrun by barbarian Picts from Scotland and Celts from Ireland. A new Celtic leader named Vortigern (active 425–450) emerged from the Welsh border-lands to rally the English Celts and, under pressure, appealed for Roman help to repel the invaders. At first the Romans responded with troops but eventually, realising the futility of their contribution, withdrew, leaving Vortigern to go it alone.

Vortigern met with the Council of British Kings who agreed to call in mercenaries from Germany. The Angles, Saxons and Jutes sent three longboats full of fighters across the Channel in return for gold. According to the English historian Bede the first consignment arrived in AD 449 led by the Saxon brothers Hengist and Horsa.³⁸ At first the arrangement worked well, so much so that the daughter of Hengist was married to Vortigern who bequeathed to him the land of Kent. But Hengist wanted more and the treachery began; he arranged a banquet of 300 British noblemen together with 300 Angles and Saxons who, on the orders of Hengist, drew their daggers and killed the British. It was known as the 'night of the long knives'. Much of southeast England was now in the hands of the Angles and Saxons who pushed what remained of Vortigern's men westwards. But many areas of England, to the west and southwest, remained free from Saxon control.

first wood and wattle Christian church named *Vetusta Ecclesia* where he was later buried together with the Holy Grail.

The recovery of the Grail became the great quest of the Knights of the Round Table. The Grail, so one version of the Arthurian story recalls³⁷, was handed over by Joseph to the knight Sir Galahad who 'took our Lord's body between his hands more than 300 years after Joseph's death, and then he died'.

Collapse of Roman Rule

In AD 330 the capital of the Roman empire was transferred to Byzantium—modern Istanbul—by Constantine the Great who renamed it Constantinople, the capital of the Byzantine Empire.

By the end of the fourth-century Rome came increasingly under attack from barbarians and as a result recalled troops from the outposts of empire. By AD 406 the Romans had gone from Britain leaving a power vacuum in their wake. England was overrun by barbarian Picts from Scotland and Celts from Ireland. A new Celtic leader named Vortigern (active AD 425–450) emerged from the Welsh border-lands to rally the English Celts and, under pressure, appealed for Roman help to repel the invaders. At first the Romans responded with troops but eventually, realising the futility of their contribution withdrew, leaving Vortigern to go it alone.

Vortigern met with the Council of British Kings who agreed to call-in mercenaries from Germany. The Angles, Saxons and Jutes sent three longboats full of fighters across the Channel in return for gold. According to the English historian Bede³⁸ the first consignment arrived in AD 449 led by the Saxon brothers Hengist and Horsa. At first the arrangement worked well. So much so that the daughter of Hengist was married to Vortigern who bequeathed to him the land of Kent. But Hengist wanted more and the treachery began; he arranged a banquet of 300 British Noblemen together with 300 Angles and Saxons who, on the orders of Hengist, drew their daggers and killed the British. It was known as the 'night of the long knives'. Much of south-east England was now in the hands of the Angles and Saxons who pushed what remained of Vortigern's men westwards. But many areas of England, to the west and south-west, remained free from Saxon control.

St. Patrick

St. Patrick (AD 389–461) was an Englishman, a one-time slave in Roman-occupied Britain who was sold to a landowner in northwest Ireland in around AD 404. He passed the days of his youth tending sheep in prayer and contemplation of God. After six years he escaped to return home across the Irish Sea. Travelling by night, to avoid detection, he walked the 321 km (200 miles) to the southeast of Ireland and begged a passage on a small boat to France. His Irish experience had raised the possibility in his mind of a divine mission to convert the Irish Celts to Christianity, but to do that he would firstly need the authority of the Church.

For twenty-one years Patrick studied Christian theology in the French monasteries of Lerins and Auxerre and during that time experienced a visionary dream calling him back to Ireland to continue his

**St. Patrick**

Figure 33. Statue of Saint Patrick (Timoleague, West Cork, Ireland) carrying the crook, the symbol of spiritual leadership.

mission. In AD 432, as a fully ordained bishop in the Church of England, he returned to Ireland to fulfil the divine order, firstly by winning over the hearts and minds of local kings and then by preaching to the Druids in the language of Mayo-Irish. In the years that followed he established a Celtic-Christian Church across Ireland. His teachings were seen as divergent, raising suspicion from the English bishops who, claiming him to be heretic, tried and failed to excommunicate him.

Patrick built the first churches and established the earliest practices of worship in Ireland. Legend says that he had divine protection; one day a powerful king was sent to ambush him and his fellows but, miraculously, they all became invisible. The king could see only a group of stags before him, and he heard voices chanting:

*Christ be in me, Christ before me,
Christ beneath me, Christ above me,
Christ at my right, Christ at my left,
Christ in my lying down, Christ in my sitting,
Christ in my rising,
Christ in the heart of everyone who thinks of me,
Christ in the mouth of everyone who speaks to me,
Christ in every eye that sees me,
Christ in every ear that hears me.*

The prayer became known as the *Deer Cry*.

Patrick is credited for introducing the Irish shamrock [the three-leaved clover] to Ireland, to represent the Holy Trinity of the Father, the Son and the Holy Ghost, but no evidence exists to support that view.

St Patrick

St Patrick (AD 389–461) was an Englishman; a one time slave in Roman occupied Britain who was sold to a landowner in north-west Ireland in around AD 404. He passed the days of his youth tending sheep in prayer and contemplation of God. After six years he escaped in an attempt to return home across the Irish Sea. Travelling by night, to avoid detection, he walked the 321 km (200 miles) to the south-east of Ireland and begged a passage on a small boat to France. His Irish experience had raised the possibility in his mind of a divine mission to convert the Irish Celts to Christianity, but to do that he would firstly need the authority of the Church.

For 21 years Patrick studied Christian theology in the French monasteries of Lerins and Auxerre and during that time experienced a visionary dream calling him back to Ireland to continue his mission. In AD 432, as a fully ordained Bishop in the Church of England, he returned to Ireland to

**St Patrick**

Figure 33. Statue of Saint Patrick, (Timoleague, West Cork, Ireland) carrying the crook, the symbol of spiritual leadership.

fulfil the divine order, firstly by winning over the hearts and minds of local kings and then by preaching to the Druids in the language of Mayo-Irish. In the years that followed he established a Celtic-Christian Church across Ireland. His teachings were seen as divergent raising suspicion from the English Bishops who, claiming him to be heretic, tried and failed to excommunicate him.

Patrick built the first churches and established the earliest practices of worship in Ireland. Legend says that he had divine protection; one day a powerful king was sent to ambush him and his fellows but, miraculously, they all became invisible. The King could see only a group of stags before him, and he heard voices chanting:

*Christ be in me, Christ before me,
Christ beneath me, Christ above me,
Christ at my right, Christ at my left,
Christ in my lying down, Christ in my sitting,
Christ in my rising,
Christ in the heart of everyone who thinks of me,
Christ in the mouth of everyone who speaks to me,
Christ in every eye that sees me,
Christ in every ear that hears me.*

The prayer became known as the *Deer Cry*.

Patrick is credited for introducing the Irish shamrock [the three-leaved clover] to Ireland, to represent the Holy Trinity of the Father, the Son and the Holy Ghost, but no evidence exists to support that view.

Notes:

- 30 May have been one and the same as King Menes.
- 31 See *The Tutankhamun Prophecies: The Mystery of the mixed-up meat*.
- 32 Asher, Benjamin, Dan, Ephraim, Gad, Issachar, Judah, Mandasseh, Naphtali, Reuben, Simeon, and Zebulun.
- 33 The body of books accepted by the Church.
- 34 *The Times* (Review article), April 10, 2004.
- 35 An Island Dependency of the U.K. located in the Irish Sea.
- 36 Fifty days after the Jewish festival of Passover [the eight-day spring festival that commemorates how the Angel of Death passed over Jews houses, so that only the Egyptian firstborn sons were killed—which is seen as divine retribution, following the Pharaoh's edict that all male Jewish infants should be killed].
- 37 *The Ultimate Encyclopaedia of Mythology*, Arthur Cotterell, Hermes House, 1999 p.13.
- 38 Bede's *Ecclesiastical History of the English People*, Ed. B. Colgrave and R. A. B. Mynors (Oxford 1969) IV. 4.

St. Patrick

St. Patrick (AD 389-461) was an Englishman, a one-time slave in Roman-occupied Britain who was sold to a landowner in northwest Ireland in around AD 404. He passed the days of his youth tending sheep in prayer and contemplation of God. After six years he escaped to return home across the Irish Sea. Travelling by night, to avoid detection, he walked the 321 km (200 miles) to the southeast of Ireland and begged a passage on a small boat to France. His Irish experience had raised the possibility in his mind of a divine mission to convert the Irish Celts to Christianity, but to do that he would firstly need the authority of the Church.

For twenty-one years Patrick studied Christian theology in the French monasteries of Lerins and Auxerre and during that time experienced a visionary dream calling him back to Ireland to continue his



St. Patrick

Figure 33. Statue of Saint Patrick (Timoleague, West Cork, Ireland) carrying the crook, the symbol of spiritual leadership.

mission. In AD 432, as a fully ordained bishop in the Church of England, he returned to Ireland to fulfil the divine order, firstly by winning over the hearts and minds of local kings and then by preaching to the Druids in the language of Mayo-Irish. In the years that followed he established a Celtic-Christian Church across Ireland. His teachings were seen as divergent, raising suspicion from the English bishops who, claiming him to be heretic, tried and failed to excommunicate him.

Patrick built the first churches and established the earliest practices of worship in Ireland. Legend says that he had divine protection; one day a powerful king was sent to ambush him and his fellows but, miraculously, they all became invisible. The king could see only a group of stags before him, and he heard voices chanting:

*Christ be in me, Christ before me,
Christ beneath me, Christ above me,
Christ at my right, Christ at my left,
Christ in my lying down, Christ in my sitting,
Christ in my rising,
Christ in the heart of everyone who thinks of me,
Christ in the mouth of everyone who speaks to me,
Christ in every eye that sees me,
Christ in every ear that hears me.*

The prayer became known as the *Deer Cry*.

Patrick is credited for introducing the Irish shamrock [the three-leaved clover] to Ireland, to represent the Holy Trinity of the Father, the Son and the Holy Ghost, but no evidence exists to support that view.

St Patrick

St Patrick (AD 389-461) was an Englishman; a one time slave in Roman occupied Britain who was sold to a landowner in north-west Ireland in around AD 404. He passed the days of his youth tending sheep in prayer and contemplation of God. After six years he escaped in an attempt to return home across the Irish Sea. Travelling by night, to avoid detection, he walked the 321km (200 miles) to the south-east of Ireland and begged a passage on a small boat to France. His Irish experience had raised the possibility in his mind of a divine mission to convert the Irish Celts to Christianity, but to do that he would firstly need the authority of the Church.

For 21 years Patrick studied Christian theology in the French monasteries of Lerins and Auxerre and during that time experienced a visionary dream calling him back to Ireland to continue his mission. In AD 432, as a fully ordained Bishop in the Church of England, he returned to Ireland to

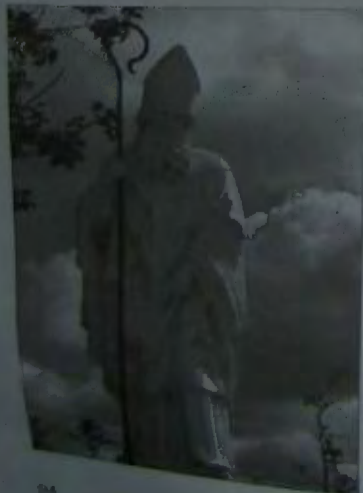

St Patrick

Figure 33. Statue of Saint Patrick (Timoleague, West Cork, Ireland) carrying the crook, the symbol of spiritual leadership.

fulfil the divine order, firstly by winning over the hearts and minds of local kings and then by preaching to the Druids in the language of Mayo-Irish. In the years that followed he established a Celtic-Christian Church across Ireland. His teachings were seen as divergent raising suspicion from the English Bishops who, claiming him to be heretic, tried and failed to excommunicate him.

Patrick built the first churches and established the earliest practices of worship in Ireland. Legend says that he had divine protection; one day a powerful king was sent to ambush him and his fellows but, miraculously, they all became invisible. The King could see only a group of stags before him, and he heard voices chanting:

*Christ be in me, Christ before me,
Christ beneath me, Christ above me,
Christ at my right, Christ at my left,
Christ in my lying down, Christ in my sitting,
Christ in my rising,
Christ in the heart of everyone who thinks of me,
Christ in the mouth of everyone who speaks to me,
Christ in every eye that sees me,
Christ in every ear that hears me.*

The prayer became known as the *Deer Cry*.

Patrick is credited for introducing the Irish shamrock [the three-leaved clover] to Ireland, to represent the Holy Trinity of the Father, the Son and the Holy Ghost, but no evidence exists to support that view.

Notes:

- 30 May have been one and the same as King Menes.
- 31 See *The Tutankhamun Prophecies: The Mystery of the mixed up meat*.
- 32 Asher, Benjamin, Dan, Ephraim, Gad, Issachar, Judah, Mandassah, Naphtali, Reuben, Simeon, and Zebulun.
- 33 The body of books accepted by the Church.
- 34 *The Times* (Review article), April 10, 2004.
- 35 An Island Dependency of the U.K. located in the Irish Sea.
- 36 Fifty days after the Jewish festival of Passover [the eight-day spring festival that commemorates how the Angel of Death passed over Jews houses, so that only the Egyptian firstborn sons were killed—which is seen as divine retribution, following the Pharaoh's edict that all male Jewish infants should be killed].
- 37 *The Ultimate Encyclopedia of Mythology*, Arthur Cotterell, Hermes House, 1999 p.13.
- 38 *Bede's Ecclesiastical History of the English People*, Ed. B. Colgrave and R. A. B. Mynors (Oxford 1969) IV. 4.

CHAPTER THREE

The Monasteries

Havens of Refuge

The spread of Christianity inspired the building of new monasteries throughout Europe and the Middle East. Devotees flocked to subscribe to the new Christian ethos of chastity, obedience and poverty.

The reason for chastity was twofold: those who chose a life of physical replication—having children—would find it difficult to purify their own soul because they would love their own children more than their neighbour's, contrary to Christian teaching that, first and foremost, demanded love of one's neighbour—which includes the neighbour's children. It says nothing about becoming attached to one's own children, nothing about preferring them to the children of others. The second reason is physiological: ejaculation of high-protein sperm in males depletes the body of a vital resource. The body then needs to use energy to replace the sperm, instead of using the energy to increase the voltage of the soul within; energies in the body should flow up the spine to make a halo, not down the spine to make sperm—which is why circumcision, as an inhibitor to masturbation, proved so popular among the Jews:

And certain men which came down from Judaea taught the Brethren, and said 'Except ye be circumcised after the manner of Moses, ye cannot be saved'. (Acts XV, 1)

In avoiding fornication St. Paul writes:

It is good for a man not to touch a woman, nevertheless, to avoid

fornication, let every man have his own wife, and let every woman have her own husband. (Corinthians VIII, 1-2)

He preferred the life of the ascetic, of the monk and the celibate priest, defaulting to marriage only when the will is weak:

But if they cannot contain [their desire] let them marry for it is better to marry than to burn. (Corinthians VII, 9)

'To burn', here, refers to the insatiable self-inspired pain born of lust and desire that distracts the mind from peaceful thought. It arises from misperception in the minds of those who desire to possess, control, consume and discard—triggering a self-sustaining drama in which the participant volunteers to engage and ends, inevitably, in self-destruction. It differs substantially from the positive attributes of suffering.

Suffering arises from outside stimuli over which the victim has little or no control. It causes pain in the mind. The wrestling mind leads to pain in the heart. Pain in the heart leads to searching of the soul and searching of the soul leads to the purging of impurity, as the wringing of a wet rag purges it of water. In this way pain purifies the heart which purifies the soul in preparation for entry into Heaven. Herein lies the heart of Christian teaching.

When we pay for our own mistakes we suffer—because we have to work longer and harder to earn the money to pay for the mistake. The mind suffers, the heart suffers and the soul purifies and goes to Heaven. The fool, who prefers others to pay for his mistakes, simply sends them to Heaven and at the same time consigns his own soul to oblivion. The wise man therefore *eagerly* pays for his own mistakes and *readily* pays for the mistakes of the fool. This is the way to Heaven. By paying for the mistakes of others Christ took the sins of the world upon himself, suffered, purified his soul and ascended to Heaven. The Theory of Iterative Spiritual Redemption (figure A20) illustrates the choices and the outcomes available. We choose our own destiny.

It becomes clear that some individuals seldom pay for their mistakes and are therefore denied access to Heaven this time around. It is the client who pays for the incompetence or ineptitude of a lawyer or barrister. It is the innocent convict who pays for the incompetence or ineptitude of the judge. In this way the innocents suffer and become pure while the guilty consign their own souls to Hell.

CHAPTER THREE

The Monasteries

Havens of Refuge

The spread of Christianity inspired the building of new monasteries throughout Europe and the Middle East. Devotees flocked to subscribe to the new Christian ethos of chastity, obedience and poverty.

The reason for chastity was twofold: those who chose a life of physical replication—having children—would find it difficult to purify their own soul because they would love their own children more than their neighbour's, contrary to Christian teaching that, first and foremost, demanded love of one's neighbour—which includes the neighbour's children. It says nothing about becoming attached to one's own children, nothing about preferring them to the children of others. The second reason is physiological: ejaculation of high protein sperm in males depletes the body of a vital resource. The body then needs to use energy to replace the sperm, instead of using the energy to increase the voltage of the soul within; energies in the body should flow up the spine to make a halo, not down the spine to make sperm—which is why circumcision, as an inhibitor to masturbation, proved so popular among the Jews:

And certain men which came down from Judaea taught the Brethren, and said 'Except ye be circumcised after the manner of Moses, ye cannot be saved' (Acts XV, 1).

In avoiding fornication St Paul writes:

It is good for a man not to touch a woman, nevertheless, to avoid fornication, let every man have his own wife, and let every woman have her own husband. (Corinthians VIII, 1-2).

He preferred the life of the ascetic, of the Monk and the celibate Priest, defaulting to marriage only when the will is weak:

But if they cannot contain [their desire] let them marry for it is better to marry than to burn. (Corinthians VII, 9).

Burning, here, refers to the insatiable self-inspired pain born of lust and desire that distracts the mind from peaceful thought. It arises from misperception in the minds of those who desire to possess, control, consume and discard—triggering a self-sustaining drama in which the participant volunteers to engage and ends, inevitably, in self-destruction. It differs substantially from the positive attributes of suffering.

Suffering arises from outside stimuli over which the victim has little or no control. It causes pain in the mind. The wrestling mind leads to pain in the heart. Pain in the heart leads to searching of the soul and searching of the soul leads to the purging of impurity, as the wringing of a wet rag purges it of water. In this way pain purifies the heart which purifies the soul in preparation for entry into Heaven. Herein lies the heart of Christian teaching.

When we pay for our own mistakes we suffer—because we have to work longer and harder to earn the money to pay for the mistake. The mind suffers, the heart suffers and the soul purifies and goes to Heaven. The fool, who prefers others to pay for his mistakes, simply sends them to Heaven and at the same time consigns his own soul to oblivion. The wise man therefore *eagerly* pays for his own mistakes and *readily* pays for the mistakes of the fool. This is the way to Heaven. By paying for the mistakes of others Christ took the sins of the world upon himself, suffered, purified his soul and ascended to Heaven. The Theory of Iterative Spiritual Redemption (figure A20) illustrates the choices and the outcomes available. We chose our own destiny.

It becomes clear that some individuals seldom pay for their mistakes and are therefore denied access to Heaven this time around; it is the client who pays for the incompetence or ineptitude of a lawyer or barrister. It is the innocent convict who pays for the incompetence or ineptitude

Herein lies the heart of the law of karma, the Universal law of action and inaction that automatically makes all wrongs right.

But many that are first shall be last; and the last shall be first. (*Matthew XIX, 30*)

It is easier for a camel to pass through the eye of a needle than for a rich man to enter into the Kingdom of God. (*Matthew XIX, 23-24*)

Retreat to the monasteries amounted to self-imposed exile where the spiritually predisposed could escape from *normal* people who are driven by desire to replicate and self-destruct. They had read the story of how normal people had nailed a perfectly innocent man to a cross, and they preferred to have none of it.

They turned their backs on the normal way of life and flocked to the monasteries that became havens of refuge and centres of prayer, work and education for those seeking salvation. There they spent their time in contemplation of God, replicating his work: carving and decorating stone into crosses and monuments, transforming precious metals and gemstones into liturgical vessels and compiling the first *illuminated* copies of biblical texts through years of toilsome work and study.

The need for texts brought with it a need for words that progressed from simple strings of capital letters to mixed texts of capital and lower-case letters. Scribes progressed, laying text onto parchment or vellum (calfskin)—using straight guidelines and dividing pages into two or three rubrics.³⁹ Sheets were then stitched together into an early form of book, a codex.

The *Codex Argenteus*, the 'silver codex', emerged in the sixth century from an Italian monastery. The bilingual *Codex Carolinus*, laid out in two columns—one Gothic, the other Latin—appeared shortly after. In AD 746 the English Benedictine monk St. Boniface (AD 680-754), who was charged with taking Christianity to Germany by Pope Gregory II, carried the Latin *Victor Codex*, of Fulda, to Germany.

Biblical manuscripts often ran to several volumes leading to the appearance of shorter versions containing just the Psalms or the Gospels beautifully decorated with coloured inks often bound with chased metal and leather. There were also portable versions of the

THE CELTIC CHRONICLES

tude of the Judge. In this way the innocents suffer and become pure while the guilty consign their own souls to Hell.

Herein lies the heart of the law of Karma, the Universal law of action and reaction that automatically makes all wrongs right.

But many that are first shall be last; and the last shall be first. (*Matthew XIX, 30*).

It is easier for a camel to pass through the eye of a needle than for a rich man to enter into the Kingdom of God. (*Matthew XIX, 23-24*).

Retreat to the monasteries amounted to self-imposed exile where the spiritually predisposed could escape from *normal* people who are driven by desire to replicate and self-destruct. They had read the story of how normal people had nailed a perfectly innocent man to a cross, and they preferred to have none of it.

They turned their backs on the normal way of life and flocked to the monasteries that became havens of refuge and centres of prayer, work and education for those seeking salvation. There they spent their time in contemplation of God, replicating his work: carving and decorating stone into crosses and monuments, transforming precious metals and gemstones into liturgical vessels and compiling the first *illuminated* copies of biblical texts through years of toilsome work and study.

The need for texts brought with it a need for words that progressed from simple strings of capital letters to mixed texts of capital and lower case letters. Scribes progressed, laying text onto parchment or vellum (calfskin)—using straight guidelines and dividing pages into two or three rubrics³⁹. Sheets were then stitched together into an early form of book, a codex.

The *Codex Argenteus*, the 'silver codex', emerged in the sixth-century from an Italian monastery. The bi-lingual *Codex Carolinus*, laid out in two columns—one Gothic the other Latin—appeared shortly after. In AD 746 The English Benedictine Monk St Boniface (AD 680-754), who was charged with taking Christianity to Germany by Pope Gregory II, carried the Latin *Victor Codex*, of Fulda, to Germany.

Biblical manuscripts often ran to several volumes leading to the appearance of shorter versions containing just the Psalms or the Gospels

books known as the 'Pocket Gospels' carried by monks on their missions. Production of texts continued by hand until the advent of paper and the development of printing around 1250. By 1440 simple woodcut blocks appeared and the introduction of moveable type in 1450 allowed a new versatility of book production hitherto unseen.

In AD 597 Pope Gregory I sent St. Augustine (d. AD 605) to England to formally convert the English to Roman Catholicism. He baptised King Ethelbert of Kent shortly after arriving at Ebbsfleet and went on to become the first archbishop of Canterbury.

The quasi-independent Celtic Christian Church established by Patrick in Ireland was by now set in its own ways and fundamental differences between the two Churches, first noticed during Patrick's time, began to deepen. The Church organisation in Ireland differed from the Episcopal system organised by bishops throughout Europe. In Ireland the monasteries were often founded by families to ensure that their own family members subsequently ruled as abbots who performed baptisms, mass and funerals and were regarded superior to bishops. Another difference concerned the dating of the Easter festival that celebrated the resurrection of Christ: Rome preferred the moveable feast falling on the first Sunday following the full moon after the spring equinox whereas the Celts preferred their own date.⁴⁰

In AD 431 Pope Celestine sent Bishop Palladius to Ireland, presumably to build upon Patrick's work.⁴¹ One of the first Irish monasteries was that of St. Enda, on Arainn (Inishmore, Aran Islands). St. Finnian's at Clonard, County Meath, became a school for monastic-founding monks who would spread the word to other parts of Britain and the Continent.

The Irish abbot St. Columba (Colm Cille, AD 521-597), who was born in County Donegal of royal descent, established several monasteries in Ireland including one at Durrow, near Tullamore, County Offaly. The seventh-century scholar Adomnan (AD 628-704), the ninth abbot of Iona (AD 679-704), in his *Vita Columbae* (the *Life of Colm Cille*) c. AD 697, describes him as:

... a perfect disciple chosen by God who experienced prophetic revelations, the power to work miracles ... experience angelic visitations ... who devoted himself to the Christian life ... who

THE MONASTERIES

beautifully decorated with coloured inks often bound with chased metal and leather. There were also portable versions of the books known as the 'Pocket Gospels' carried by monks on their missions. Production of texts continued by hand until the advent of paper and the development of printing around 1250. By 1440 simple woodcut blocks appeared and the introduction of moveable type in 1450 allowed a new versatility of book production hitherto unseen.

In AD 597 Pope Gregory I sent St Augustine (d. AD 605) to England to formally convert the English to Roman Catholicism. He baptised King Ethelbert of Kent shortly after arriving at Ebbsfleet and went on to become the first Archbishop of Canterbury.

The quasi-independent Celtic Christian Church established by Patrick in Ireland, was by now set in its own ways and fundamental differences between the two Churches, first noticed during Patrick's times, began to deepen. The Church organisation in Ireland differed from the Episcopal system organised by Bishops throughout Europe. In Ireland the monasteries were often founded by families to ensure that its own family members subsequently ruled as Abbots who performed baptisms, mass and funerals and were regarded superior to Bishops. Another difference concerned the dating of the Easter festival that celebrated the resurrection of Christ: Rome preferred the moveable feast falling on the first Sunday following the full moon after the spring equinox whereas the Celts preferred their own date.⁴⁰

In AD 431 Pope Celestine sent Bishop Palladius to Ireland, presumably to build upon Patrick's work⁴¹. One of the first Irish monasteries was that of St Enda, on Arainn (Inishmore, Aran Islands). St Finnian's at Clonard, County Meath, became a school for monastic founding monks who would spread the word to other parts of Britain and the Continent.

The Irish Abbot St Columba (Colm Cille, AD 521-597), who was born in County Donegal of royal descent, established several monasteries in Ireland including one at Durrow, near Tullamore, County Offaly. The seventh-century scholar Adomnan (AD 628-704), the ninth abbot of Iona (AD 679-704), in his *Vita Columbae* (the *Life of Colm Cille*) c. AD 697, describes him as:

... a perfect disciple chosen by God who experienced prophetic revelations, the power to work miracles ... experience angelic visitations ...

Herein lies the heart of the law of karma, the Universal law of action and inaction that automatically makes all wrongs right.

But many that are first shall be last; and the last shall be first. (*Matthew XIX, 30*)

It is easier for a camel to pass through the eye of a needle than for a rich man to enter into the Kingdom of God. (*Matthew XIX, 23-24*)

Retreat to the monasteries amounted to self-imposed exile where the spiritually predisposed could escape from *normal* people who are driven by desire to replicate and self-destruct. They had read the story of how normal people had nailed a perfectly innocent man to a cross, and they preferred to have none of it.

They turned their backs on the normal way of life and flocked to the monasteries that became havens of refuge and centres of prayer, work and education for those seeking salvation. There they spent their time in contemplation of God, replicating his work: carving and decorating stone into crosses and monuments, transforming precious metals and gemstones into liturgical vessels and compiling the first *illuminated* copies of biblical texts through years of toilsome work and study.

The need for texts brought with it a need for words that progressed from simple strings of capital letters to mixed texts of capital and lower-case letters. Scribes progressed, laying text onto parchment or vellum (calfskin)—using straight guidelines and dividing pages into two or three rubrics.³⁹ Sheets were then stitched together into an early form of book, a codex.

The *Codex Argenteus*, the 'silver codex', emerged in the sixth century from an Italian monastery. The bilingual *Codex Carolinus*, laid out in two columns—one Gothic, the other Latin—appeared shortly after. In AD 746 the English Benedictine monk St. Boniface (AD 680-754), who was charged with taking Christianity to Germany by Pope Gregory II, carried the Latin *Victor Codex*, of Fulda, to Germany.

Biblical manuscripts often ran to several volumes leading to the appearance of shorter versions containing just the Psalms or the Gospels beautifully decorated with coloured inks often bound with chased metal and leather. There were also portable versions of the

THE CELTIC CHRONICLES

tude of the Judge. In this way the innocents suffer and become pure while the guilty consign their own souls to Hell.

Herein lies the heart of the law of Karma, the Universal law of action and reaction that automatically makes all wrongs right.

But many that are first shall be last; and the last shall be first. (*Matthew XIX, 30*).

It is easier for a camel to pass through the eye of a needle than for a rich man to enter into the Kingdom of God. (*Matthew XIX, 23-24*).

Retreat to the monasteries amounted to self-imposed exile where the spiritually predisposed could escape from *normal* people who are driven by desire to replicate and self-destruct. They had read the story of how normal people had nailed a perfectly innocent man to a cross, and they preferred to have none of it.

They turned their backs on the normal way of life and flocked to the monasteries that became havens of refuge and centres of prayer, work and education for those seeking salvation. There they spent their time in contemplation of God, replicating his work; carving and decorating stone into crosses and monuments, transforming precious metals and gemstones into liturgical vessels and compiling the first *illuminated* copies of biblical texts through years of toilsome work and study.

The need for texts brought with it a need for words that progressed from simple strings of capital letters to mixed texts of capital and lower case letters. Scribes progressed, laying text onto parchment or vellum (calfskin)—using straight guidelines and dividing pages into two or three rubrics³⁹. Sheets were then stitched together into an early form of book, a codex.

The *Codex Argenteus*, the 'silver codex', emerged in the sixth-century from an Italian monastery. The bi-lingual *Codex Carolinus*, laid out in two columns—one Gothic the other Latin—appeared shortly after. In AD 746 The English Benedictine Monk St Boniface (AD 680-754), who was charged with taking Christianity to Germany by Pope Gregory II, carried the Latin *Victor Codex*, of Fulda, to Germany.

Biblical manuscripts often ran to several volumes leading to the appearance of shorter versions containing just the Psalms or the Gospels

books known as the 'Pocket Gospels' carried by monks on their missions. Production of texts continued by hand until the advent of paper and the development of printing around 1250. By 1440 simple woodcut blocks appeared and the introduction of moveable type in 1450 allowed a new versatility of book production hitherto unseen.

In AD 597 Pope Gregory I sent St. Augustine (d. AD 605) to England to formally convert the English to Roman Catholicism. He baptised King Ethelbert of Kent shortly after arriving at Ebbsfleet and went on to become the first archbishop of Canterbury.

The quasi-independent Celtic Christian Church established by Patrick in Ireland was by now set in its own ways and fundamental differences between the two Churches, first noticed during Patrick's time, began to deepen. The Church organisation in Ireland differed from the Episcopal system organised by bishops throughout Europe. In Ireland the monasteries were often founded by families to ensure that their own family members subsequently ruled as abbots who performed baptisms, mass and funerals and were regarded superior to bishops. Another difference concerned the dating of the Easter festival that celebrated the resurrection of Christ: Rome preferred the moveable feast falling on the first Sunday following the full moon after the spring equinox whereas the Celts preferred their own date.⁴⁰

In AD 431 Pope Celestine sent Bishop Palladius to Ireland, presumably to build upon Patrick's work.⁴¹ One of the first Irish monasteries was that of St. Enda, on Arainn (Inishmore, Aran Islands). St. Finnian's at Clonard, County Meath, became a school for monastic-founding monks who would spread the word to other parts of Britain and the Continent.

The Irish abbot St. Columba (Colm Cille, AD 521-597), who was born in County Donegal of royal descent, established several monasteries in Ireland including one at Durrow, near Tullamore, County Offaly. The seventh-century scholar Adomnan (AD 628-704), the ninth abbot of Iona (AD 679-704), in his *Vita Columbae* (the *Life of Colm Cille*) c. AD 697, describes him as:

... a perfect disciple chosen by God who experienced prophetic revelations, the power to work miracles ... experience angelic visitations ... who devoted himself to the Christian life ... who

THE MONASTERIES

beautifully decorated with coloured inks often bound with chased metal and leather. There were also portable versions of the books known as the 'Pocket Gospels' carried by monks on their missions. Production of texts continued by hand until the advent of paper and the development of printing around 1250. By 1440 simple woodcut blocks appeared and the introduction of moveable type in 1450 allowed a new versatility of book production hitherto unseen.

In AD 597 Pope Gregory I sent St Augustine (d. AD 605) to England to formally convert the English to Roman Catholicism. He baptised King Ethelbert of Kent shortly after arriving at Ebbsfleet and went on to become the first Archbishop of Canterbury.

The quasi-independent Celtic Christian Church established by Patrick in Ireland, was by now set in its own ways and fundamental differences between the two Churches, first noticed during Patrick's times, began to deepen. The Church organisation in Ireland differed from the Episcopal system organised by Bishops throughout Europe. In Ireland the monasteries were often founded by families to ensure that its own family members subsequently ruled as Abbots who performed baptisms, mass and funerals and were regarded superior to Bishops. Another difference concerned the dating of the Easter festival that celebrated the resurrection of Christ; Rome preferred the moveable feast falling on the first Sunday following the full moon after the spring equinox whereas the Celts preferred their own date⁴⁰.

In AD 431 Pope Celestine sent Bishop Palladius to Ireland, presumably to build upon Patrick's work⁴¹. One of the first Irish monasteries was that of St Enda, on Arainn (Inishmore, Aran Islands). St Finnian's at Clonard, County Meath, became a school for monastic founding monks who would spread the word to other parts of Britain and the Continent.

The Irish Abbot St Columba (Colm Cille, AD 521-597), who was born in County Donegal of royal descent, established several monasteries in Ireland including one at Durrow, near Tullamore, County Offaly. The seventh-century scholar Adomnan (AD 628-704), the ninth abbot of Iona (AD 679-704), in his *Vita Columbae* (the *Life of Colm Cille*) c. AD 697, describes him as:

... a perfect disciple chosen by God who experienced prophetic revelations, the power to work miracles ... experience angelic visitations...

with God's help studying wisdom and keeping his body chaste . . . spent thirty-four years as an island-soldier of Christ. (*Vita Columbae*, Adobnan [quoted from *The Encyclopaedia of Ireland*, Gill & Macmillan, 2003])

This refers to the time he spent after sailing from the northern tip of Ireland in AD 563 with twelve companions to build the monastery on the Scottish island of Iona. From there he made missionary journeys to the mainland that played a major part in the conversion of Britain to Christianity.

In AD 635 another Irish monk, St Aidan (AD 600–651), a prodigy of St Columba, established a Christian monastery on causeway-connected Lindisfarne (Holy Island) just off the coast of Northumberland, north-east England. Aidan, like Patrick in Ireland before him, did not personally recognise the Church of Rome and refused to speak Latin.

It was not until AD 664 that King Oswey of Northumbria, at the Synod of Whitby, decided to adopt the Roman form of Christianity in Britain [later repealed during the Reformation]. Papal authority was established in Ireland at the same time allowing inspiring bishops from both sides of the Irish Sea to make regular visits to the pope in Rome.

The Works of Angels

It was towards the end of the seventh century that monasteries on the islands of Lindisfarne and Iona produced the finest of the Celtic-style illuminated manuscripts. The Romans, during their occupation of England, had subdued and suppressed Celtic art in favour of their own. But the Romans never reached Ireland where the Celtic tradition had continued unbroken. With the Romans gone and Irish monks flooding into Britain, the Celtic La Tène style, favoured by monks, was given a new lease on life. Lavishly illustrated manuscripts adorned with Celtic animals (figure 34), decorative calligraphy (figure 35), and Celtic interlaced continuous-line knot-work (figure 37)—already established on ancient stone monuments—began to appear in manuscript form; the twelfth-century writer Gerald of Wales could only describe them as 'the works of angels'.

The Lord hath filled him with the spirit of God, in wisdom, in

Celtic Mythology



Figure 34. Animal drawings, carved into stone and copied into manuscripts, feature widely in Celtic art. (From George Bain's *Celtic Art—Methods of Construction*)

Celtic Continuous-line Interlacing



Figure 35. Textual characters embellished with scrolls and continuous-line drawing were used extensively in the early Christian manuscripts. (From George Bain's *Celtic Art—Methods of Construction*)

who devoted himself to the Christian life... who with God's help studying wisdom and keeping his body chaste... spent thirty-four years as an island-soldier of Christ (*Vita Columbae*, Adobnan [quoted from *The Encyclopaedia of Ireland*, Gill & Macmillan, 2003]).

This refers to the time he spent after sailing from the northern tip of Ireland in AD 563 with 12 companions to build the monastery on the Scottish Island of Iona. From there he made missionary journeys to the mainland that played a major part in the conversion of Britain to Christianity.

In AD 635 another Irish monk, St Aidan (AD 600–651), a prodigy of St Columba, established a Christian monastery on causeway-connected Lindisfarne (Holy Island) just off the coast of Northumberland, north-east England. Aidan, like Patrick in Ireland before him, did not personally recognise the Church of Rome and refused to speak Latin.

It was not until AD 664 that King Oswey of Northumbria, at the Synod of Whitby, decided to adopt the Roman form of Christianity in Britain [later repealed during the Reformation]. Papal authority was established in Ireland at the same time inspiring Bishops from both sides of the Irish Sea to make regular visits to the Pope in Rome.

The Works of Angels

It was towards the end of the seventh-century that monasteries on the islands of Lindisfarne and Iona produced the finest of the Celtic-style illuminated manuscripts. The Romans, during their occupation of England, had subdued and suppressed Celtic art in favour of their own. But the Romans never reached Ireland where the Celtic tradition had continued unbroken. With the Romans gone and Irish monks flooding into Britain the Celtic La Tène style, favoured by monks, was given a new lease of life. Lavishly illustrated manuscripts adorned with Celtic animals (figure 34), decorative calligraphy (figure 35), and Celtic interlaced continuous-line knot-work (figure 37)—already established on ancient stone monuments—began to appear in manuscript form; the twelfth-century writer Gerald of Wales could only describe them as 'the works of angels'.

The Lord hath filled him with the spirit of God, in wisdom, in under-

Celtic Mythology

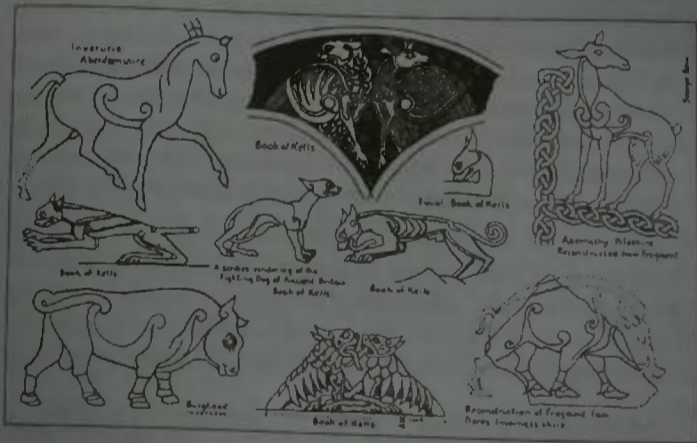

Figure 34. (a) Animal drawings, carved into stone and copied into manuscripts, feature widely in Celtic Art. (From George Bain's *Celtic Art—Methods of Construction*).

Celtic Continuous-line Interlacing

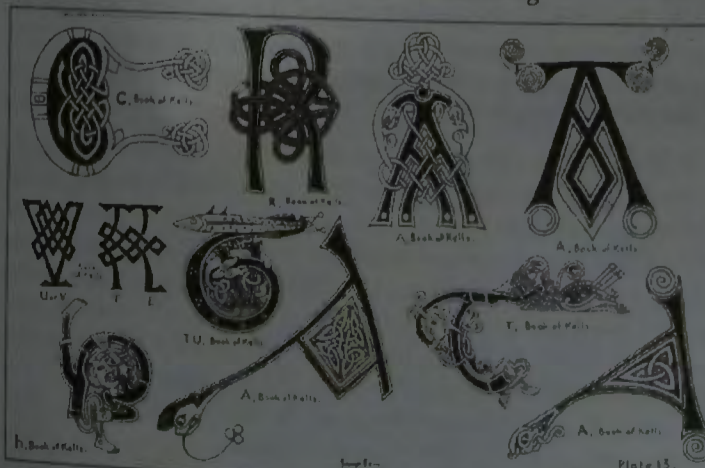

Figure 35. Textual characters embellished with scrolls and continuous-line drawing were used extensively in the early Christian manuscripts. (From George Bain's *Celtic Art—Methods of Construction*).

understanding, and in knowledge, and in all manner of workmanship and to devise curious works, to work in gold, and in silver, and in brass, and in the cutting of stones, to set them, and in the carving of wood, to make any manner of cunning work. Them hath he filled with wisdom of heart, to work all manner of work, of the engraver, and the cunning workman, and of the embroiderer, in blue, and in purple, in scarlet and in fine linen, and of the weaver, even of them that do any work, and those that devise cunning work. (*Exodus XXXV, 31-35*)

We know that the [so-called] Book of Lindisfarne was written in around AD 698 because Aldred, the later provost of Chester-le-Street in around AD 950, added a gloss [a commentary] in English—the earliest surviving translation of the Gospels in English—and a colophon [a publisher's imprint] naming Bishop Eadfrith of Lindisfarne as the maker of the original:

Eadfrith, Bishop of Lindisfarne Church [in AD 698] originally wrote this book for God and St. Cuthbert and jointly for all the saints whose relics are on the Island. And Ethewald, Bishop of Lindisfarne Islanders impressed it on the outside and covered it, as he well knew how to do. And Billfrith, the anchorite, forged the ornaments which are on the outside and adorned it with gold and with gems and with gilt-silver. And Aldred, unworthy and most miserable priest, glossed it in English between the lines.

The format of the illuminated monastic books from Lindisfarne, Iona, Kells and Durrow vary but, generally, they all contain the texts of the four Gospels with portrait illustrations of the Apostles, carpet pages and initial pages. Layout and illustration were constrained by the format; there were no sentences or paragraphs, just long strings of letters that had to be separated by larger initial letters that helped readers find their way around the text. Carpet pages were purely ornamental and played no part in the stories but separated sections. The initial page of each Gospel was extravagantly decorated with Celtic patterns (plate 16) inspired from earlier designs found on Celtic weapons, jewellery and horse-trappings. Portraits of the Apostles in the books of Kells and Durrow were Romanised in style rather than Celtic, no doubt because they were based on portrait versions sent out from Rome.

standing, and in knowledge, and in all manner of workmanship and to devise curious works, to work in gold, and in silver, and in brass, and in the cutting of stones, to set them, and in the carving of wood, to make any manner of cunning work. Them hath he filled with wisdom of heart, to work all manner of work, of the engraver, and the cunning workman, and of the embroiderer, in blue, and in purple, in scarlet and in fine linen, and of the weaver, even of them that do any work, and those that devise cunning work (*Exodus XXXV, 31-35*).

We know that the [so-called] Book of Lindisfarne was written in around AD 698 because Aldred, the later Provost of Chester-le-Street in around AD 950, added a gloss [a commentary] in English—the earliest surviving translation of the Gospels in English—and a colophon [a publisher's imprint] naming Bishop Eadfrith of Lindisfarne as the maker of the original:

Eadfrith, Bishop of Lindisfarne Church [in AD 698] originally wrote this book for God and St Cuthbert and jointly for all the saints whose relics are on the Island. And Ethewald, Bishop of Lindisfarne Islanders impressed it on the outside and covered it, as he well knew how to do. And Billfrith, the anchorite, forged the ornaments which are on the outside and adorned it with gold and with gems and with gilt-silver. And Aldred, unworthy and most miserable priest, glossed it in English between the lines.

The format of the illuminated monastic books from Lindisfarne, Iona, Kells and Durrow vary but, generally, they all contain the texts of the four Gospels with portrait illustrations of the Apostles, Carpet Pages and Initial Pages. Layout and illustration was constrained by the format; there were no sentences or paragraphs, just long strings of letters that had to be separated by larger initial letters that helped readers find their way around the text. Carpet Pages were purely ornamental and played no part in the stories but separated sections. The Initial Page of each Gospel was extravagantly decorated with Celtic patterns (plate 16) inspired from earlier designs found on Celtic weapons, jewellery and horse-trappings. Portraits of the Apostles in the books of Kells and Durrow were Romanised in style rather than Celtic, no doubt because they were based on portrait versions sent out from Rome.

The earliest theological texts to arrive in Britain and Ireland came with the missionaries during Roman times and were written in formal Roman *uncial* [with round letters not joined together] and *half-uncial* [with distinct ascenders and descenders].

The oldest surviving Irish manuscripts, dating from the end of the sixth century, include the *Springmount Bog* writing tables, the *Codex Usserianus Primus* (Gospel book fragment) and the *Cathach*, all written in what has since become known as *insular majuscule* [Island script—formed with distinctive triangular wedge-shaped serifs on the verticals]. The script was written with a chisel-edged quill held parallel to the page, producing solid letters consisting of thick downstrokes and thin horizontal strokes. This gave the text a highly horizontal appearance that was later adopted and developed by the island monasteries at Lindisfarne (plate 16) and Iona.

Where the Book of Kells was written is uncertain. Many believe it derived from the monastery of Iona, Scotland, in around AD 795. Church transactions copied into it prove that it must have been in Kells by the eleventh century.

Lindisfarne monks, fleeing raids from Vikings, carried their manuscripts along with other precious liturgical artefacts to Iona for safekeeping. When the monk Alcuin heard of the first devastating raid on the monastery at Lindisfarne on 8th June AD 793, he wrote a warning letter to Ethewald, bishop of Lindisfarne:

Consider [them] carefully, brothers, and examine [them] diligently, lest perchance the unaccustomed and un-heard of evil practice [ensnares you]... Consider the dress, the way of wearing the hair, the luxurious habits of the princes and people. (Letter from Aluin to Ethewald, *The Annals of Ulster*, AD 793)

But the refuge was not to last. Iona was pillaged in AD 795, 802 and again in 806, forcing the monks across the Irish Sea to the new monastery at Kells [which was completed in 814]. Shortly after, the Vikings mounted assaults on Irish monasteries, once again forcing the monks to abandon their sanctuaries and to hide or bury their treasures. From AD 840 onwards the Vikings established coastal and lakeside settlements in Ireland.

The Book of Kells consists of 340 vellum folios [680 pages] written

The earliest theological texts to arrive in Britain and Ireland came with the missionaries during Roman times and were written in formal Roman *uncial* [with round letters not joined together] and *half-uncial* [with distinct ascenders and descenders].

The oldest surviving Irish manuscripts, dating from the end of the sixth-century, include the *Springmount Bog* writing tables, the *Codex Usserianus Primus* (Gospel book fragment) and the *Cathach*, all written in what has since become known as *insular majuscule* [Island script—formed with distinctive triangular wedge-shaped serifs on the verticals]. The script was written with a chisel-edged quill held parallel to the page, producing solid letters comprised of thick down-strokes and thin horizontal strokes. This gave the text a highly horizontal appearance that was later adopted and developed by the island monasteries at Lindisfarne (plate 16) and Iona.

Where the Book of Kells was written is uncertain. Many believe it derived from the monastery of Iona, Scotland, in around AD 795. Church transactions copied into it prove that it must have been in Kells by the eleventh century.

Lindisfarne monks, fleeing raids from Vikings, carried their manuscripts along with other precious liturgical artefacts to Iona for safekeeping. When the monk Alcuin heard of the first devastating raid on the monastery at Lindisfarne on 8th June AD 793 he wrote a warning letter to Ethewald, Bishop of Lindisfarne:

Consider [them] carefully, brothers, and examine [them] diligently, lest perchance the unaccustomed and un-heard of evil practice [ensnares you]... Consider the dress, the way of wearing the hair, the luxurious habits of the princes and people (Letter from Aluin to Ethewald, *The Annals of Ulster*, AD 793)

But the refuge was not to last. Iona was pillaged in AD 795, 802 and again in 806, forcing the monks across the Irish Sea to the new monastery at Kells [which was completed in 814]. Shortly after, the Vikings mounted assaults on Irish monasteries once again forcing the monks to abandon their sanctuaries and to hide or bury their treasures. From AD 840 onwards the Vikings established coastal and lakeside settlements in Ireland.

by at least three scribes in insular majuscule. The Gospels are based on the Latin Vulgate preferred by Rome (commissioned by Pope Damascus from St. Jerome in AD 404) mixed with parts from the less reliable Old Latin translation. These were accompanied by preliminary texts, including a list of Hebrew names, *breves causae*—headings, Gospel sections, the *argumenta*—brief lives of the Apostles, and the highly decorated *Canon tables*—that divided the text into numbered sections and enabled the reader to cross-reference between Gospels.

The colourful design of the book was probably created by three artists using a variety of styles derived from Celtic, Germanic, Pictish [early Scottish] and Mediterranean influence. It is revered as the most colourful of the illuminated manuscripts and features full-page illustrations of Christ, Christ with the Virgin Mary, miniatures of the Temptation and the Arrest, and a page with symbolic portraits of the four Apostles: Mark as a lion, Matthew as an angel, John as an eagle and Luke as an ox, referring to passages from the Bible:

As for the likeness of their faces, they four had the face of a man, and the face of a lion on the right side; and they four had the face of an ox on the left side; they four also had the face of an eagle. (Ezekiel I, 10)

And before the throne there was a sea of glass like unto crystal: and in the midst of the throne, and round about the throne, were four beasts full of eyes before and behind. And the first beast was like a lion, and the second beast like a calf and the third beast had the face of a man, and the fourth beast was like a flying eagle. (Revelation IV, 6-7)

And they sung as it were a new song before the throne, and before the four beasts, and the elders; and no man could learn that song but the hundred and forty-four thousand, which were redeemed from the Earth. (Revelation XIV, 2-3)

Generally speaking, the four symbols represented Christ as a lion—the King [of the jungle], as the sacrificial ox, as the eagle—ascending to Heaven, and the Holy Spirit in Heaven—the angel [although in the book of Durrow, John is shown as the lion].

The oldest surviving insular majuscule illuminated manuscript is

The Book of Kells consists of 340 vellum folios [680 pages] written by at least three scribes in insular majuscule. The Gospels are based on the Latin Vulgate preferred by Rome (commissioned by Pope Damascus from St. Jerome in AD 404) mixed with parts from the less reliable Old Latin translation. These were accompanied by preliminary texts; including a list of Hebrew names, *breves causae*—headings, Gospel sections, the *argumenta*—brief lives of the Apostles, and the highly decorated *Canon tables*—that divided the text into numbered sections and enabled the reader to cross-reference between Gospels.

The colourful design of the book was probably created by three artists using a variety of influences derived from Celtic, Germanic, Pictish [early Scottish] and Mediterranean influence. It is revered as the most colourful of the illuminated manuscripts and features full page illustrations of Christ, Christ with the Virgin Mary, miniatures of the Temptation and the Arrest, and a page with symbolic portraits of the four Apostles: Mark as a lion, Matthew as an angel, John as an eagle and Luke as an ox, referring to passages from the Bible:

As for the likeness of their faces, they four had the face of a man, and the face of a lion on the right side; and they four had the face of an ox on the left side; they four also had the face of an eagle. (Ezekiel I, 10)

And before the throne there was a sea of glass like unto crystal: and in the midst of the throne, and round about the throne, were four beasts full of eyes before and behind. And the first beast was like a lion, and the second beast like a calf and the third beast had the face of a man, and the fourth beast was like a flying eagle. (Revelation IV, 6-7)

And they sung as it were a new song before the throne, and before the four beasts, and the elders; and no man could learn that song but the hundred and forty-four thousand, which were redeemed from the Earth. (Revelation XIV, 2-3)

Generally speaking, the four symbols represented Christ as a Lion—the King [of the jungle], as the sacrificial ox, as the eagle—ascending to Heaven, and the Holy Spirit in Heaven—the angel [although in the book of Durrow John is shown as the lion].

contained within the *Psalter Cathach of St. Columba*, compiled during the times of St. Columba, which contains few enlarged initials while a few remaining vestiges of a Gospel book, found at Durham, England, contain early plait-work previously only encountered on stonework.

The first fully illuminated book to contain the Gospels was the Book of Durrow, from around AD 680, which contains an inscription saying that it was copied out by St. Columba, suggesting that it had been written before that of Kells or Lindisfarne. It appeared in the Columban monastery at Durrow, Ireland, in around AD 680 but was not written there. It seems likely, from the style and decoration, that it was written at Lindisfarne or at least another monastery in Northumbria, England, founded by St. Columba, who probably carried it to Durrow. It contains 248 leaves of vellum and measures approximately 245 x 145 mm (9.65 x 5.7 inches). Again, it contains St. Jerome's fourth-century Latin Vulgate translation of the Gospels and prefaces from him, interpretations of Hebrew names, and Canon tables. The text is written in insular majuscule and some of the illustrations derive from the earlier Old Latin Vulgate. Eleven full-colour pages emblazoned with red, yellow, green and brown inks include symbols, rather than portraits, of the Apostles and the Carpet Pages are richly decorated with biting animals, roundels (solar crosses), spirals within spirals (like those of figure 30, representing solar radiation) linked to each other by a flowing motif known as a trumpet spiral—all contained within an elaborate interlaced continuous-line pattern.

The Book of Lindisfarne reaches a watershed in Celtic illumination with a new, higher level of decoration and sophistication. It contains the four Gospels of the Latin Vulgate, each opening with a picture of the Apostle and his symbol. The portraits of the Apostles are less stylized than those of the Book of Kells and contain classical and Byzantine influence; the Apostles appear in Greek-style clothing and their names appear in Latinised Greek. Like the others the book also contains Canon tables, prefaces, *argumenta* and material on the feasts of saints. The five initial pages, one at the beginning and one between each of the Gospels, and the carpet pages are lavishly decorated with fine interlaced fretwork and running borders containing parades of intertwining bird and animal heads each snapping at the one ahead.

The oldest surviving insular majuscule illuminated manuscript is contained within the *Psalter Cathach of St. Columba*, compiled during the times of St. Columba that contains few enlarged initials while a few remaining vestiges of a Gospel book, found at Durham, England, contain early plait-work previously only encountered on stonework.

The first fully illuminated book to contain the Gospels was the Book of Durrows, from around AD 680, which contains an inscription saying that it was copied out by St. Columba, suggesting that it had been written before that of Kells or Lindisfarne. It appeared in the Columban monastery at Durrow, Ireland, in around AD 680 but was not written there. It seems likely, from the style and decoration, that it was written at Lindisfarne or at least another monastery in Northumbria, England, founded by St. Columba who probably carried it to Durrow. It contains 248 leaves of vellum and measures approximately 245 by 145mm (9.65 by 5.7 inches). Again, it contains St. Jerome's fourth-century Latin Vulgate translation of the Gospels and prefaces from him, interpretations of Hebrew names, and Canon tables. The text is written in insular majuscule and some of the illustrations derive from the earlier Old Latin Vulgate. Eleven full-colour pages emblazoned with red, yellow, green and brown inks include symbols, rather than portraits, of the Apostles and the Carpet Pages are richly decorated with biting animals, roundels (solar-crosses), spirals within spirals (like those of figure 30 representing solar radiation) linked to each other by a flowing motif known as a trumpet spiral—all contained within an elaborate interlaced continuous-line pattern.

The Book of Lindisfarne reaches a watershed in Celtic illumination with a new higher level of decoration and sophistication. It contains the four Gospels of the Latin Vulgate each opening with a picture of the Apostle and his symbol. The portraits of the Apostles are less stylized than those of the Books of Kells and contain classical and Byzantine influence; the Apostles appear in Greek-style clothing and their names appear in Latinised Greek. Like the others the book also contains Canon tables, prefaces, *argumenta* and material on the feasts of Saints. The five Initial Pages, one at the beginning and one between each of the Gospels and the Carpet Pages are lavishly decorated with fine interlaced fret-

Decoding the Celtic Designs—Continuous-line Drawing

The links with the Sun and the scriptures are patently evident in the illuminated manuscripts and it is clear that the painstaking efforts of the monks, singing praise to God, have been duly rewarded in the quality of the works. But why spend such a disproportionate amount of time and effort on Gospel decoration that might have been better spent converting the fallen? Such consideration implores us to re-arrange the words of Rabbi Moses Maimonides quoted earlier:

Every time you find in a book a decoration or a pointless embellishment which appears to defy reason and common sense then be sure that it contains a profound allegory veiling a deeply mysterious truth; and the greater the absurdity of the pattern, the deeper the wisdom of spirit. [author's amendments in italics]

Continuous-line drawing is not unique to the Celts, as the *Lost Tomb of Viracocha* observed:

Maria Reiche was not the first or last to notice that each of the Nazca desert line drawings [see figure 36, the monkey, herein] was made by one single continuous line that circumscribed the [drawing of the] creature . . . A similar technique is used in a common children's game where one of the rules of the game requires that the pencil should not be lifted from the drawing surface until the picture is completed in its entirety.

There are other characteristics of the drawings . . . The first is that there must have been a reason for the rule, for not lifting the pencil . . . from the paper (desert) and, moreover, that this reason must have had something to do with either the method used to construct the lines or the message which was intended to be conveyed by the lines (or both). Engineers familiar with electrical circuits will immediately note a similarity here; early facsimile machines used either electro-sensitive or thermal recording paper. Generally, the underside of the roll of recording paper connects to one side of an electrical circuit whereas the signal-carrying pen makes contact with the topside surface of the paper.

Whenever a signal appears on the pen it flows through the paper to the other side of the circuit, burning a black mark into the

paper sandwiched between the two conductors. It goes without saying that if ever the pen should cease to make contact with the paper then current would be forced to stop, and the paper-marking (drawing) would also stop, irrespective of the presence of a signal on the tip of the pen. This means that the pen must be in contact with the paper at all times; it must not be lifted from the paper during the period the drawing is taking place. The continuous-line characteristic of the lines of Nazca tells us that whoever drew the lines understood this principle; that a continuous current-like process was actually employed in the line-drawing process. If we recall, it was the continuous flow of ultraviolet light (the current) from the Sun on the surface of the [Nazca] basin that oxidised the rocks [on the ground] in the first place and allowed the lines to be created the way that they were. This draws our attention to understanding the nature and capabilities of solar radiation. In

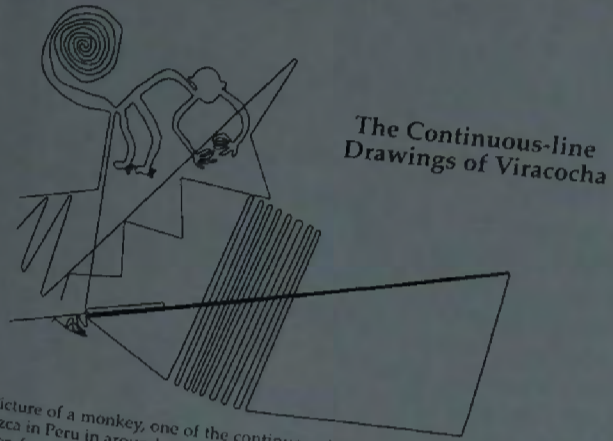

The Continuous-line Drawings of Viracocha

Figure 36. Picture of a monkey, one of the continuous-line drawings scraped into the desert sands of Nazca in Peru in around AD 500. One of the rules of this style of drawing precludes lifting the pen from the paper. The drawings were hence generated using an uninterrupted (constant-flow) process; this tells us that solar radiation oxidised the surface pebbles, turning them blackish-brown, in contrast to the lighter-coloured subsurface pebbles of which the lines consist (figure A25 shows two more drawings from Nazca). The monkey in this drawing has four fingers on the right hand and five on the left; one finger is missing from the hands, just like the Viracocha bas-relief carving from the Gateway of the Sun at Tiahuanaco (figure A6f). The monkey embraces the largest of three identical shapes (triangles) and the statue of Viracocha is the largest of the three standing statues in the Temple of the Stone Heads at Tiahuanaco (figure A2a). The monkey desert line drawing tells us, therefore, that the pictures were also created (drawn) by the hand of Viracocha.

work and running borders containing parades of intertwining bird and animal heads each snapping at the one ahead.

Decoding the Celtic Designs—Continuous-line drawing

The links with the Sun and the scriptures are patently evident in the illuminated manuscripts and it is clear that the painstaking efforts of the monks, singing praise to God, have been duly rewarded in the quality of the works. But why spend such a disproportionate amount of time and effort on Gospel decoration that might have been better spent converting the fallen? Such consideration implores us to re-arrange the words of Rabbi Moses Maimonides quoted earlier:

Every time you find in a book a decoration or a pointless embellishment which appears to defy reason and common sense then be sure that it contains a profound allegory veiling a deeply mysterious truth; and the greater the absurdity of the pattern, the deeper the wisdom of spirit. [Author's amendments in Italics].

Continuous-line drawing is not unique to the Celts, as the *Lost Tomb of Viracocha* observed:

Maria Reiche was not the first or last to notice that each of the Nazca desert line drawings (see figure 36, the monkey, herein) was made by one single continuous line that circumscribed the [drawing of the] creature. . . A similar technique is used in a common children's game where one of the rules of the game requires that the pencil should not be lifted from the drawing surface until the picture is completed in its entirety.

There are other characteristics of the drawings. . . The first is that there must have been a reason for the rule, for not lifting the pencil. . . from the paper (desert) and, moreover, that this reason must have had something to do with either the method used to construct the lines or the message which was intended to be conveyed by the lines (or both). Engineers familiar with electrical circuits will immediately note a similarity here: early facsimile machines used either electro-sensitive or thermal recording paper. Generally, the underside of the roll of recording paper connects to one side of an electrical circuit whereas the

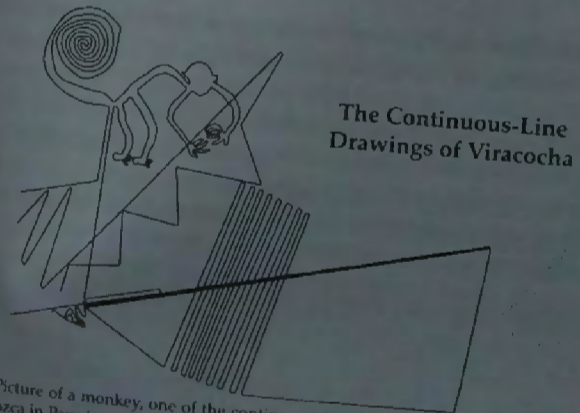

The Continuous-Line Drawings of Viracocha

Figure 36. Picture of a monkey, one of the continuous-line drawings scraped into the desert sands of Nazca in Peru in around AD 500. One of the rules of this style of drawing precludes lifting the pen from the paper. The drawings were hence generated using an uninterrupted (constant-flow) process; this tells us that solar radiation oxidised the surface pebbles, turning them blackish-brown, in contrast to the lighter-coloured subsurface pebbles of which the lines comprise (figure A25 shows two more drawings from Nazca). The monkey in this drawing has four fingers on the right hand and five on the left; one finger is missing from the hands, just like the Viracocha bas-relief carving from the Gateway of the Sun at Tiahuanaco (figure A6f). The monkey embraces the largest of three identical shapes (triangles) and the statue of Viracocha is the largest of the three standing statues in the Temple of the Stone Heads at Tiahuanaco (figure A2a). The monkey desert line drawing tells us, therefore, that the pictures were also created (drawn) by the hand of Viracocha.

signal-carrying pen makes contact with the topside surface of the paper.

Whenever a signal appears on the pen it flows through the paper to the other side of the circuit, burning a black mark into the paper sandwiched between the two conductors. It goes without saying that if ever the pen should cease to make contact with the paper then current would be forced to stop, and the paper-marking (drawing) would also stop, irrespective of the presence of a signal on the tip of the pen. This means that the pen must be in contact with the paper at all times; it must not be lifted from the paper during the period the drawing is taking place. The continuous-line characteristic of the lines of Nazca tells us that whoever drew the lines understood this principle; that a continuous current-like process was actually employed in the line-drawing

using the continuous-line technique the ancients were attempting to draw our attention to the power of the Sun. (*The Lost Tomb of Viracocha*, Maurice Cotterell, Headline, 2001)

The section concluded with an analysis of the creature patterns recognising that they could only have been created by a miracle, by Viracocha, the son of God who walked the lands of Peru in around AD 500.

In the same way, by using the continuous-line technique the Celts were attempting to draw our attention to the power of the Sun and to the fact that the continuous-line drawing of the Celts could only have been enabled by God, on Earth.

Moreover, the dedicated scribe-monks no doubt sought salvation through work, always keeping their pen on the paper, always vigilant:

Watch ye therefore: for ye know not when the master of the house cometh, at even or at midnight, or at the cock-crowing or in the morning: Lest coming suddenly he find you sleeping. (*Mark XIII*, 35-36)

It was their way of getting to Heaven.

Decoding the Celtic Knot-work Patterns

The Scottish artist and scholar George Bain, born in Scrabster, Caithness, Scotland, in 1881, devoted his life to studying and teaching the rudiments of construction of Celtic interlacing patterns and knot-work found in Celtic stonework and, later, in the illuminated manuscripts. For his efforts he became known as the 'father of modern Celtic design'. After he died in 1968 his family donated his works to the Groom House museum in Rosemarkie. William McLellan & Co., of Glasgow, published his book *Celtic Art—the Methods of Construction* in 1951.

In the introduction Bain comments:

This elementary textbook is prepared especially for use in elementary and secondary schools. It will also serve to give instruction to Art Students, Artists, and Art workers in a multitude of crafts. There is much that will be useful to the archaeologist and the historian, although I have refrained from dealing with such problems,

Encoding of Celtic Numbers

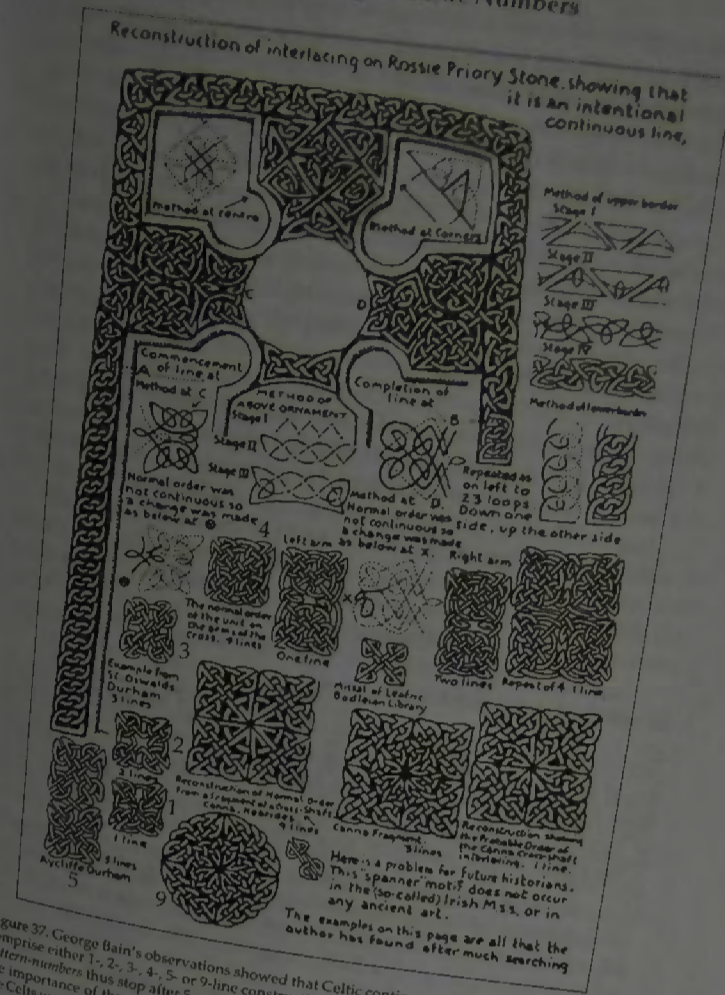

Figure 37. George Bain's observations showed that Celtic continuous-line interlacing patterns comprise either 1-, 2-, 3-, 4-, 5- or 9-line construction. No 6-line pattern has been found. Celtic pattern-numbers thus stop after 5, apart from the 9-line pattern (the Sun), drawing attention to the importance of the numbers 6 and 9 (666 and 999) and the Sun, showing once again that the Celts were aware of the super-science of the Sun and the higher orders of spirituality. (From George Bain's *Celtic Art—Methods of Construction*)

process. If we recall, it was the continuous flow of ultraviolet light (the current) from the Sun on the surface of the [Nazca] basin that oxidised the rocks [on the ground] in the first place and allowed the lines to be created the way that they were. This draws our attention to understanding the nature and capabilities of solar radiation. In using the continuous-line technique the ancients were attempting to draw our attention to the power of the Sun. (*The Lost Tomb of Viracocha*, Maurice Cotterell, Headline, 2001).

The section concluded with an analysis of the creature-patterns recognising that they could only have been created by a miracle, by Viracocha, the son of God who walked the lands of Peru in around AD 500.

In the same way, by using the continuous-line technique the Celts were attempting to draw our attention to the power of the Sun and to the fact that the continuous-line drawing of the Celts could only have been enabled by God, on Earth.

Moreover, the dedicated scribe-monks no doubt sought salvation through work, always keeping their pen on the paper, always vigilant:

Watch ye therefore: for ye know not when the master of the house cometh, at even or at midnight, or at the cock-crowing or in the morning: Lest coming suddenly he find you sleeping (*Mark XIII*, 35-36).

It was their way of getting to Heaven.

Decoding the Celtic Knot-work patterns

The Scottish artist and scholar George Bain, born in Scrabster, Caithness, Scotland, in 1881, devoted his life to studying and teaching the rudiments of construction of Celtic interlacing patterns and knot-work found in Celtic stonework and, later, in the illuminated manuscripts. For his efforts he became known as the 'father of modern Celtic design'. After he died in 1968 his family donated his works to the Groom House museum in Rosemarkie. William McLellan & Co., of Glasgow, published his book *Celtic Art—the methods of Construction* in 1951.

In the Introduction Bain comments:

This elementary textbook is prepared especially for use in elementary

and secondary schools. It will also serve to give instruction to Art Students, Artists, and Art workers in a multitude of crafts. There is much that will be useful to the archaeologist and the historian, although I have refrained from dealing with such problems, for the primary purpose of this book is to give to others the results of my many years of research into the methods used by the ancient artists... Realising the meagreness of the written language, especially when used by me as a medium for the clear transmitting of instructions on the partly artistic, partly geometrical and partly mathematical method peculiar to many forms of Celtic Art and particularly to that of the Pictish School, I have put the onus of understanding upon the student by compelling the close observation of every stage of the methods with very few words to hinder or to assist. Many years of experimenting have led me to believe that when once this slight initial difficulty has been overcome in this manner of reading, to dispense with words is beneficial. [Author's Italics].

With genuine humility, gained by years of research into the possible methods of the great intellectual artist and craftsmen of the Pictish nation, who produced the great art of the cross-slab stones of East Pict and their counterparts in the Books of Durrow, Kells and Lindisfarne, the Tara Brooch, the Ardagh Chalice and other masterpieces of the Celtic Jewellers art, I present the result of my studies... The extreme minuteness of the art of the illuminated manuscripts and the impossibility of ordinary eyes perceiving much of its contents show, conclusively, that the artists did not display their skill for human eyes and human applause.

They were imbued with the idea that the eyes of God would detect errors and worked solely to glorify him. Their aids to eyesight and the tools that enabled them to draw a line with exactness beyond the skill of moderns may never be known. Referring to a page of the *Book of Armagh*, one of the 'Pocket Gospels', Professor J. O. Westwood wrote:

In the space of about a quarter of an inch... I counted with a magnifying glass no less than one hundred and fifty-eight interlacings of a slender ribbon... the ground of white lines edged with black ones

Reconstruction of interlacing on Rossie Priory Stone, showing that it is an intentional continuous line,

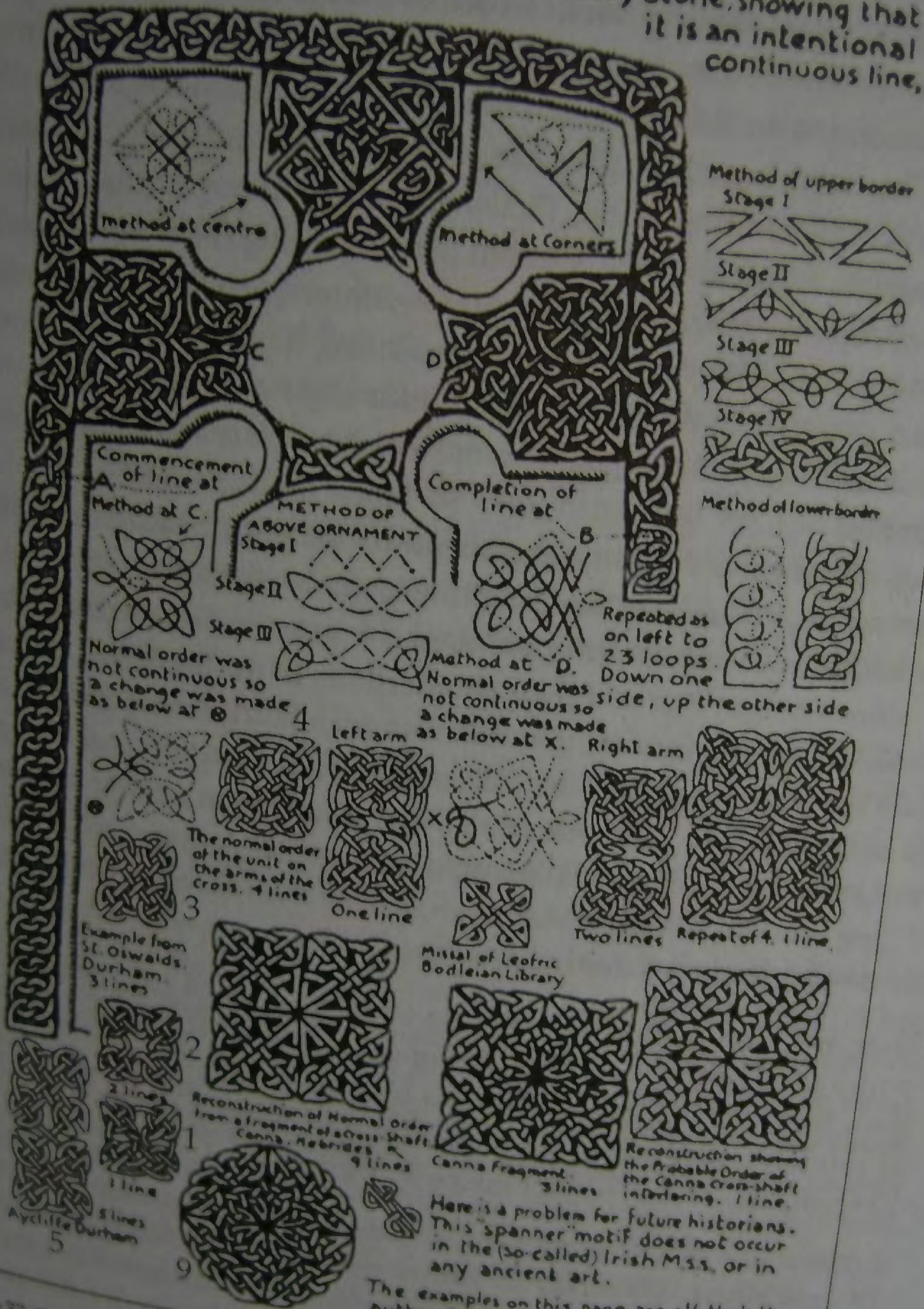

Figure 37. George Bain's observations showed that Celtic continuous-line interlacing patterns comprise either 1-, 2-, 3-, 4-, 5- or 9-line construction. No 6-line pattern has been found. Celtic patterns thus stop after 5, apart from the 9-line pattern (the Sun), drawing attention to the importance of the numbers 6 and 9 [666 and 999] and the Sun, showing once again that the Celts were aware of the super-science of the Sun and the higher orders of spirituality. (From George Bain's *Celtic Art—Methods of Construction*)

Encoding of Celtic Numbers

Reconstruction of interlacing on Rossie Priory Stone, showing that it is an intentional continuous line.

Method at centre

Method at Corners

Method of upper border
Stage I
Stage II
Stage III
Stage IV

Method of lower border

Commencement of line at A

Completion of line at B

Method at C

METHOD OF ABOVE ORNAMENT
Stage I
Stage II
Stage III

Method at D

Repeated as on left to 23 loops. Down one side, up the other side

Normal order was not continuous so a change was made as below at ⓐ

Normal order was not continuous so a change was made as below at Ⓧ

Left arm

Right arm

The normal order of the unit on the arms of the cross. 4 lines

One line

Two lines

Repeat of 4 line

Example from St Oswalds Durham 3 lines

Mistal of Leofric Bodleian Library

Reconstruction of Normal Order from a fragment of a cross-shaft Camb. Bridges 9 lines

Canna fragment 3 lines

Reconstruction showing the Probable Order of the Canna Cross-shaft interlacing. 1 line

Here is a problem for future historians. This 'spanner' motif does not occur in the (so-called) Irish MSS. or in any ancient art.

The examples on this page are all that the author has found after much searching

Figure 17. George Bain's observations showed that Celtic continuous-line interlacing patterns comprise either 1-, 2-, 3-, 4-, 5- or 9-line construction. No 6-line pattern has been found. Celtic patterns never stop after 5, apart from the 9-line pattern (the Sun), drawing attention to the importance of the numbers 6 and 9 (616 and 999) and the Sun, showing once again that the Celts were aware of the super-science of the Sun and the higher orders of spirituality. (From George Bain's *Celtic Art—Methods of Construction*)

for the primary purpose of this book is to give to others the results of my many years of research into the methods used by the ancient artists . . . Realising the meagreness of the written language, especially when used by me as a medium for the clear transmitting of instructions on the partly artistic, partly geometrical and partly mathematical method peculiar to many forms of Celtic Art and particularly to that of the Pictish School, I have put the onus of understanding upon the student by compelling the close observation of every stage of the methods with *very few words* to hinder or to assist. Many years of experimenting have led me to believe that when once this slight initial difficulty has been overcome in this manner of reading, *to dispense with words is beneficial.* [author's italics]

With genuine humility, gained by years of research into the possible methods of the great intellectual artist and craftsmen of the Pictish nation, who produced the great art of the cross-slab stones of East Pict and their counterparts in the Books of Durrow, Kells and Lindisfarne, the Tara Brooch, the Ardagh Chalice and other masterpieces of the Celtic jewellers art, I present the result of my studies . . . The extreme minuteness of the art of the illuminated manuscripts and the impossibility of ordinary eyes perceiving much of its contents show, conclusively, that the artists did not display their skill for human eyes and human applause.

They were imbued with the idea that the eyes of God would detect errors and worked solely to glorify him. Their aids to eyesight and the tools that enabled them to draw a line with exactness beyond the skill of moderns may never be known. Referring to a page of the *Book of Armagh*, one of the 'pocket gospels', Professor J. O. Westwood wrote:

In the space of about a quarter of an inch . . . I counted with a magnifying glass no less than one hundred and fifty-eight interlacings of a slender ribbon pattern formed of white lines edged with black ones upon a black background. No wonder that tradition should allege that these unerring lines should have been traced by angels. (*Celtic Art—the Methods of Construction*, George Bain, William McLellan & Son, Glasgow, 1951)

Bain sketched profusely the designs found on the standing-stones and

in the manuscripts. Figure 34 shows some of the animal figures he catalogued from Scottish stones and the *Book of Kells*. His investigations are revealing. The sketch of the 'fighting dog' (figure 34, centre) from the *Book of Kells* is identical to the cast-bronze ones that feature on the Basse Yutz flagons (plate 14) that date to the much earlier period of 400 BC, meaning that the beast must have been favoured by the Celts in decorative art for over 1,000 years.

He also noticed that the interlaced Celtic knot-work patterns fall into groups consisting of 1-line designs, 2-line designs, 3-line designs, 4-line designs, 5-line designs and 9-line designs (figure 37). Curiously [at least it must have been to him], he never found any designs made up of 6 individual lines or 7, or 8, although this did not seem to trouble him. Bain must be congratulated for his incredible achievements, but it never occurred to him that the patterns might amount to Celtic representations of the numbers of 1, 2, 3, 4, 5, and 9. After all, if they did represent numbers, why would the numbers 6, 7, and 8 be missing?

To the esoteric Celt the fact that the numbers stop after 5 and restart at 9 was important. It announced to the world that the Celts were acutely aware of the body (6) and the Soul (9), and given that the pattern for the number 9 resembles the Sun (figure 37), they must have been preoccupied with the Sun and its effects on Earth.

Figure 38 recalls a section of the numbers matrix from the Pyramid of Inscriptions at Palenque (figure A17). The numbers of 6, 7, 8 are likewise missing from the matrix and can only be found by decoding the beads in the jade necklace that adorned the neck of the dead Lord Pacal in his sarcophagus. When the beads are counted and rationalised the missing numbers appear, not as themselves but as factors of other compound numbers. The message of the matrix of Lord Pacal was hence twofold: there was no place for the number 666 in his tomb and the completed matrix (which finishes with 99999) multiplied by the cycles of time used by the Maya [20 days, 260 days, 360 days, 7,200 days and 144,000 days] throws up the Birth of Venus number, 1,366,560 days.

Figure 38 likewise shows that the Celts encoded the same information into their knot-work numbering system and the analysis may be continued to reveal the same and additional information (figure 39);

upon a black background. No wonder that tradition should allege that these unerring lines should have been traced by angels (*Celtic Art—the methods of construction*, George Bain, Wm. McLellan & Son, Glasgow, 1951).

Bain sketched profusely the designs found on the standing-stones and in the manuscripts. Figure 34 shows some of the animal figures he catalogued from Scottish stones and the *Book of Kells*. His investigations are revealing. The sketch of the 'fighting dog' (figure 34, centre) from the *Book of Kells* is identical to the cast bronze ones that feature on the Basse Yutz flagons (plate 14) that date to the much earlier period of 400 BC, meaning that the beast must have been favoured by the Celts in decorative art for over 1,000 years.

He also noticed (figure 37) that the interlaced Celtic knot-work patterns fall into groups comprising of 1-line designs, 2-line designs, 3-line designs, 4-line designs, 5-line designs and 9-line designs. Curiously [at least it must have been to him] he never found any designs made up of 6 individual lines or 7, or 8, although this did not seem to trouble him. Bain must be congratulated for his incredible achievements, but it never occurred to him that the patterns might amount to Celtic representations of the numbers of 1, 2, 3, 4, 5 and 9. After all, if they did represent numbers, why would the numbers 6, 7 and 8 be missing?

To the esoteric Celt the fact that the numbers stop short of 6 and restart at 9 was important. It announced to the world that the Celts were acutely aware of the body (6) and the Soul (9) and given that the pattern for the number 9 resembles the Sun (figure 37) they must have been preoccupied with the Sun and its effects on Earth.

Figure 38 recalls a section of the numbers matrix from the Pyramid of Inscriptions at Palenque (figure A17). The numbers of 6, 7, 8 are likewise missing from the matrix and can only be found by decoding the beads in the jade necklace that adorned the neck of the dead Lord Pacal in his sarcophagus. When the beads are counted and rationalised the missing numbers appear, not as themselves but as factors of other compound numbers. The message of the matrix of Lord Pacal was hence twofold: there was no place for the number 666 in his tomb and the completed matrix (which finishes with 99999) multiplied by the cycles of time used

The Mummies of China



Plate 1. In 1994 J.P. Mallory and Victor H. Mair announced the discovery of caucasian-type mummies—up to 4,000 years old—buried in the second largest desert in the world. The dry sand had perfectly preserved the bodies and the clothes they wore; (a) Loulan mummy, known as the 'Beauty of Loulan', c. 2000 BC, from the Tarim Basin, Chinese Gumugou, Cherchan. (b) 55-year old white, bearded, male found near the same site, c. 1000 BC, buried with three females (tomb 2, Urumchi Museum). (c) Blonde-haired mummy, c. 1000 BC. (d) Zaghunluq baby (tomb 1) c. 1000 BC (aged around 12 months). (e) Mummy found in the same site, c. 1000 BC, wearing a blue felt bonnet and a woolen shroud secured with a blue felt band.

for the primary purpose of this book is to give to others the results of my many years of research into the methods used by the ancient artists... Realising the meagreness of the written language, especially when used by me as a medium for the clear transmitting of instructions on the partly artistic, partly geometrical and partly mathematical method peculiar to many forms of Celtic Art and particularly to that of the Pictish School, I have put the onus of understanding upon the student by compelling the close observation of every stage of the methods with *very few words* to hinder or to assist. Many years of experimenting have led me to believe that when once this slight initial difficulty has been overcome in this manner of reading, *to dispense with words is beneficial.* [author's italics]

With genuine humility, gained by years of research into the possible methods of the great intellectual artist and craftsmen of the Pictish nation, who produced the great art of the cross-slab stones of East Pict and their counterparts in the Books of Durrow, Kells and Lindisfarne, the Tara Brooch, the Ardagh Chalice and other masterpieces of the Celtic jewellers art, I present the result of my studies... The extreme minuteness of the art of the illuminated manuscripts and the impossibility of ordinary eyes perceiving much of its contents show, conclusively, that the artists did not display their skill for human eyes and human applause.

They were imbued with the idea that the eyes of God would detect errors and worked solely to glorify him. Their aids to eyesight and the tools that enabled them to draw a line with exactness beyond the skill of moderns may never be known. Referring to a page of the *Book of Armagh*, one of the 'pocket gospels', Professor J. O. Westwood wrote:

In the space of about a quarter of an inch... I counted with a magnifying glass no less than one hundred and fifty-eight interlacements of a slender ribbon pattern formed of white lines edged with black ones upon a black background. No wonder that tradition should allege that these unerring lines should have been traced by angels. (*Celtic Art—the Methods of Construction*, George Bain, William McLellan & Son, Glasgow, 1951)

Bain sketched profusely the designs found on the standing-stones and

in the manuscripts. Figure 34 shows some of the animal figures he catalogued from Scottish stones and the *Book of Kells*. His investigations are revealing. The sketch of the 'fighting dog' (figure 34, centre) from the *Book of Kells* is identical to the cast-bronze ones that feature on the Basse Yutz flagons (plate 14) that date to the much earlier period of 400 BC, meaning that the beast must have been favoured by the Celts in decorative art for over 1,000 years.

He also noticed that the interlaced Celtic knot-work patterns fall into groups consisting of 1-line designs, 2-line designs, 3-line designs, 4-line designs, 5-line designs and 9-line designs (figure 37). Curiously [at least it must have been to him], he never found any designs made up of 6 individual lines or 7, or 8, although this did not seem to trouble him. Bain must be congratulated for his incredible achievements, but it never occurred to him that the patterns might amount to Celtic representations of the numbers of 1, 2, 3, 4, 5, and 9. After all, if they did represent numbers, why would the numbers 6, 7, and 8 be missing?

To the esoteric Celt the fact that the numbers stop after 5 and restart at 9 was important. It announced to the world that the Celts were acutely aware of the body (6) and the Soul (9), and given that the pattern for the number 9 resembles the Sun (figure 37), they must have been preoccupied with the Sun and its effects on Earth.

Figure 38 recalls a section of the numbers matrix from the Pyramid of Inscriptions at Palenque (figure A17). The numbers of 6, 7, 8 are likewise missing from the matrix and can only be found by decoding the beads in the jade necklace that adorned the neck of the dead Lord Pacal in his sarcophagus. When the beads are counted and rationalised the missing numbers appear, not as themselves but as factors of other compound numbers. The message of the matrix of Lord Pacal was hence twofold: there was no place for the number 666 in his tomb and the completed matrix (which finishes with 99999) multiplied by the cycles of time used by the Maya [20 days, 260 days, 360 days, 7,200 days and 144,000 days] throws up the Birth of Venus number, 1,366,560 days.

Figure 38 likewise shows that the Celts encoded the same information into their knot-work numbering system and the analysis may be continued to reveal the same and additional information (figure 39);

upon a black background. No wonder that tradition should allege that these unerring lines should have been traced by angels (*Celtic Art—the methods of construction*, George Bain, Wm. McLellan & Son, Glasgow, 1951).

Bain sketched profusely the designs found on the standing-stones and in the manuscripts. Figure 34 shows some of the animal figures he catalogued from Scottish stones and the *Book of Kells*. His investigations are revealing. The sketch of the 'fighting dog' (figure 34, centre) from the *Book of Kells* is identical to the cast bronze ones that feature on the Basse Yutz flagons (plate 14) that date to the much earlier period of 400 BC, meaning that the beast must have been favoured by the Celts in decorative art for over 1,000 years.

He also noticed (figure 37) that the interlaced Celtic knot-work patterns fall into groups comprising of 1-line designs, 2-line designs, 3-line designs, 4-line designs, 5-line designs and 9-line designs. Curiously [at least it must have been to him] he never found any designs made up of 6 individual lines or 7, or 8, although this did not seem to trouble him. Bain must be congratulated for his incredible achievements, but it never occurred to him that the patterns might amount to Celtic representations of the numbers of 1, 2, 3, 4, 5 and 9. After all, if they did represent numbers, why would the numbers 6, 7 and 8 be missing?

To the esoteric Celt the fact that the numbers stop short of 6 and restart at 9 was important. It announced to the world that the Celts were acutely aware of the body (6) and the Soul (9) and given that the pattern for the number 9 resembles the Sun (figure 37) they must have been preoccupied with the Sun and its effects on Earth.

Figure 38 recalls a section of the numbers matrix from the Pyramid of Inscriptions at Palenque (figure A17). The numbers of 6, 7, 8 are likewise missing from the matrix and can only be found by decoding the beads in the jade necklace that adorned the neck of the dead Lord Pacal in his sarcophagus. When the beads are counted and rationalised the missing numbers appear, not as themselves but as factors of other compound numbers. The message of the matrix of Lord Pacal was hence twofold: there was no place for the number 666 in his tomb and the completed matrix (which finishes with 99999) multiplied by the cycles of time used

The Mummies of China



Fig. 1. In 1994 J.P. Mallory and Victor H. Mair announced the discovery of caucasian-type mummies—up to 6,000 years old—buried in the wastelands of China's Tarim Basin in the Taklamakan desert, the second largest desert in the world. The dry sand had perfectly preserved the bodies and the clothes they wore; (a) Loulan mummy, known as the 'Beauty of Loulan', c. 2000 BC, from the Xinjiang region; (b) 55-year old white, bearded, male mummy, c. 1000 BC, buried with three females (tomb 2); (c) mummy wearing a dyed blue robe, c. 1000 BC; (d) 7-year-old mummy, c. 1000 BC.

using the continuous-line technique the ancients were attempting to draw our attention to the power of the Sun. (*The Lost Tomb of Viracocha*, Maurice Cotterell, Headline, 2001)

The section concluded with an analysis of the creature patterns recognising that they could only have been created by a miracle, by Viracocha, the son of God who walked the lands of Peru in around AD 500.

In the same way, by using the continuous-line technique the Celts were attempting to draw our attention to the power of the Sun and to the fact that the continuous-line drawing of the Celts could only have been enabled by God, on Earth.

Moreover, the dedicated scribe-monks no doubt sought salvation through work, always keeping their pen on the paper, always vigilant:

Watch ye therefore: for ye know not when the master of the house cometh, at even or at midnight, or at the cock-crowing or in the morning: Lest coming suddenly he find you sleeping. (*Mark XII*, 35-36)

It was their way of getting to Heaven.

Decoding the Celtic Knot-work Patterns

The Scottish artist and scholar George Bain, born in Scrabster, Caithness, Scotland, in 1881, devoted his life to studying and teaching the rudiments of construction of Celtic interlacing patterns and, later, in the illuminated manuscripts. For his efforts he became known as the 'father of modern Celtic design'. After he died in 1968 his family donated his works to the Groam House museum in Rosemarkie. William McLellan & Co., of Glasgow, published his book *Celtic Art - the Methods of Construction* in 1951.

In the introduction Bain comments:

This elementary textbook is prepared especially for use in elementary and secondary schools. It will also serve to give instruction to Art Students, Artists, and Art workers in a multitude of crafts. There is much that will be useful to the archaeologist and the historian, although I have refrained from dealing with such problems;

Encoding of Celtic Numbers

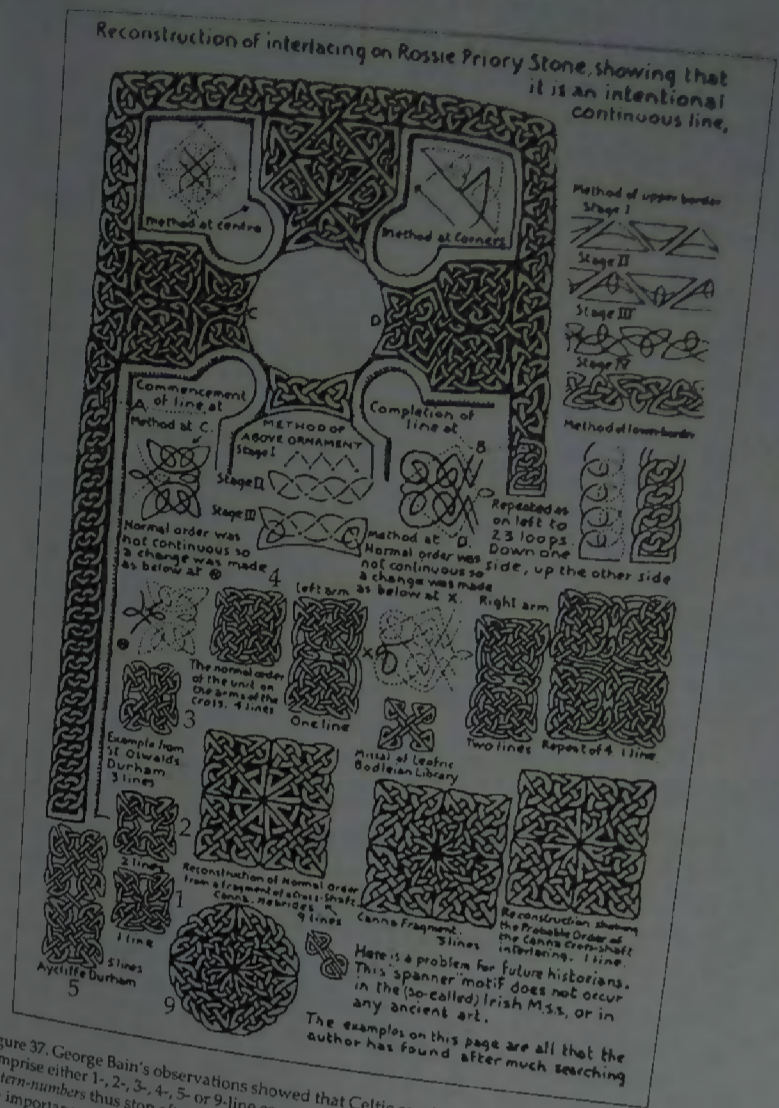

Figure 37. George Bain's observations showed that Celtic continuous-line interlacing patterns comprise either 1-, 2-, 3-, 4-, 5- or 9-line construction. No 6-line pattern has been found. Celtic pattern-numbers thus stop after 5, apart from the 9-line pattern (the Sun), drawing attention to the importance of the numbers 6 and 9 [666 and 999] and the Sun, showing once again that the Celts were aware of the super-science of the Sun and the higher orders of spirituality. (From George Bain's *Celtic Art - Methods of Construction*)



Plate 24 The Mosaic Mask of Palenque transparencies, set to 99.9°, reveal a complex picture confirming that Lord Pacal (who made the mask), Viracocha and Christ were all one and the same spiritual energy. (a) The main character is the man with the hat from the tomb of Viracocha Pachacamac (box-framed) in Peru. (b) Viracocha also appears as a crab (grapple) across the man's face. The [egg-shaped] face of the Bat God (with appendages on the forehead) in turn covers the face of the crab. (c) The soul of the man can be seen in the centre of his hat, coming from a hole in his head (see also plate 23g). (d) The soul is caught in the open beak of an eagle who carries it away to the heavens. (e) Just beneath the soul a Christ-like figure stands, emulating the Crucifixion, carrying the compasses of the freemason in his hands (his face and identification). The eagle carries the soul to the heavens. (f) The man

Encoding of Celtic Numbers

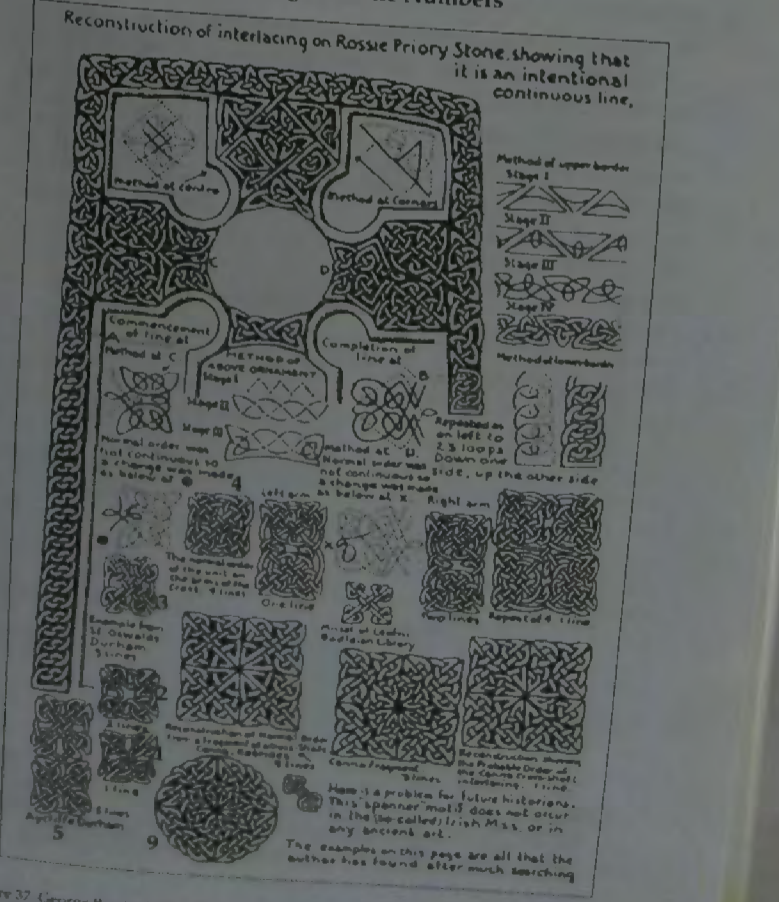

Figure 37. George Bain's observations showed that Celtic continuous-line interlacing patterns comprise either 1-, 2-, 3-, 4-, 5- or 9-line construction. No 6-line pattern has been found. Celtic pattern-numbers thus stop after 5, apart from the 9-line pattern (the Sun), drawing attention to the importance of the numbers 6 and 9 [666 and 999] and the Sun, showing once again that the Celts were aware of the super-science of the Sun and the higher orders of spirituality. (From George Bain's *Celtic Art - Methods of Construction*)

for the primary purpose of this book is to give to others the results of my many years of research into the methods used by the ancient artists... Realising the meagreness of the written language, especially when used by me as a medium for the clear transmitting of instructions on the partly artistic, partly geometrical and partly mathematical method peculiar to many forms of Celtic Art and particularly to that of the Pictish School, I have put the onus of understanding upon the student by compelling the close observation of every stage of the methods with *very few words* to hinder or to assist. Many years of experimenting have led me to believe that when once this slight initial difficulty has been overcome in this manner of reading, *to dispense with words is beneficial.* [author's italics]

With genuine humility, gained by years of research into the possible methods of the great intellectual artist and craftsmen of the Pictish nation, who produced the great art of the cross-slab stones of East Pict and their counterparts in the Books of Durrow, Kells and Lindisfarne, the Tara Brooch, the Ardagh Chalice and other masterpieces of the Celtic jewellers art, I present the result of my studies... The extreme minuteness of the art of the illuminated manuscripts and the impossibility of ordinary eyes perceiving much of its contents show, conclusively, that the artists did not display their skill for human eyes and human applause.

They were imbued with the idea that the eyes of God would detect errors and worked solely to glorify him. Their aids to eyesight and the tools that enabled them to draw a line with exactness beyond the skill of moderns may never be known. Referring to a page of the *Book of Armagh*, one of the 'pocket gospels', Professor J. O. Westwood wrote:

In the space of about a quarter of an inch... I counted with a magnifying glass no less than one hundred and fifty-eight inter-lacements of a slender ribbon pattern formed of white lines edged with black ones upon a black background. No wonder that tradition should allege that these unerring lines should have been traced by angels. (*Celtic Art—the Methods of Construction*, George Bain, William McLellan & Son, Glasgow, 1951)

Bain sketched profusely the designs found on the standing-stones and

in the manuscripts. Figure 34 shows some of the animal figures he catalogued from Scottish stones and the Book of Kells. His investigations are revealing. The sketch of the 'fighting dog' (figure 34, centre) from the Book of Kells is identical to the cast-bronze ones that feature on the Basse Yutz flagons (plate 14) that date to the much earlier period of 400 BC, meaning that the beast must have been favoured by the Celts in decorative art for over 1,000 years.

He also noticed that the interlaced Celtic knot-work patterns fall into groups consisting of 1-line designs, 2-line designs, 3-line designs, 4-line designs, 5-line designs and 9-line designs (figure 37). Curiously [at least it must have been to him], he never found any designs made up of 6 individual lines or 7, or 8, although this did not seem to trouble him. Bain must be congratulated for his incredible achievements, but it never occurred to him that the patterns might amount to Celtic representations of the numbers of 1, 2, 3, 4, 5, and 9. After all, if they did represent numbers, why would the numbers 6, 7, and 8 be missing?

To the esoteric Celt the fact that the numbers stop after 5 and restart at 9 was important. It announced to the world that the Celts were acutely aware of the body (6) and the Soul (9), and given that the pattern for the number 9 resembles the Sun (figure 37), they must have been preoccupied with the Sun and its effects on Earth.

Figure 38 recalls a section of the numbers matrix from the Pyramid of Inscriptions at Palenque (figure A17). The numbers of 6, 7, 8 are likewise missing from the matrix and can only be found by decoding the beads in the jade necklace that adorned the neck of the dead Lord Pacal in his sarcophagus. When the beads are counted and rationalised the missing numbers appear, not as themselves but as factors of other compound numbers. The message of the matrix of Lord Pacal was hence twofold: there was no place for the number 666 in his tomb and the completed matrix (which finishes with 99999) multiplied by the cycles of time used by the Maya [20 days, 260 days, 360 days, 7,200 days and 144,000 days] throws up the Birth of Venus number, 1,366,560 days.

Figure 38 likewise shows that the Celts encoded the same information into their knot-work numbering system and the analysis may be continued to reveal the same and additional information (figure 39);

by the Maya [20 days, 260 days, 360 days, 7,200 days and 144,000 days] throws up the Birth of Venus number, 1,366,560 days.

Figure 38 likewise shows that the Celts encoded the same information into their knot-work numbering system and the analysis may be continued to reveal the same and additional information (figure 39); when the missing numbers of 678 are subtracted from the number of the body [666] (figure 39a) the result is -012. When the mirror image [representing the Soul] of the missing numbers (876) is subtracted from the number of the soul [999] the result is +123. This immediately tells us that the body (-) is of the opposite polarity [voltage] as the soul (+) as earlier hypothesised in the Theory of Iterative Spiritual Redemption (figure A20).

Continuing the resulting numerical series; 012, 123... produces the number 234. The same sequence of 234 was also found in the troop formations of Pit number 3 of Ch'in Shi Huangdi's terracotta Army in China [there were 2 troops in one chamber, 3 troops in another, and 4 troops in another when read according to instructions in the tomb]. In that case it was followed by a zero [there were no troops in the north-east corner of the chamber]. Here again we have the same sequence 234 followed by nothing, giving 2340, 2,340 revolutions of the planet Venus (seen from Earth) of 584 days = 1,366,560 days—the Maya Birth of Venus number which recognises that Lord Pacal, like Jesus, was Venus.

The illuminated manuscripts of the Celts thus contain the super-science of the Sun and the higher orders of spirituality.

There are other lesser-known illuminated works, not yet mentioned; the Celtic missionary St Willibrord embarked on an evangelical mission to the Frisian Islands, off north-west Holland, in AD 690 and was appointed Archbishop there in AD 695. Three years later he founded a monastery at Echternach, Luxembourg, where monks at the scriptoria made copies of illuminated manuscripts. One of these was the *Echternach Gospels*. The colophon says that the text was copied from an original that had been revised in AD 558 by Eugippius, the Abbot of a monastery near

The *Lichfield Gospels* was produced in around AD 740, between the appearance of the books of Lindisfarne (in AD 698) and Kells (c. AD 795). It is not known where it was written but an inscription at the end of St

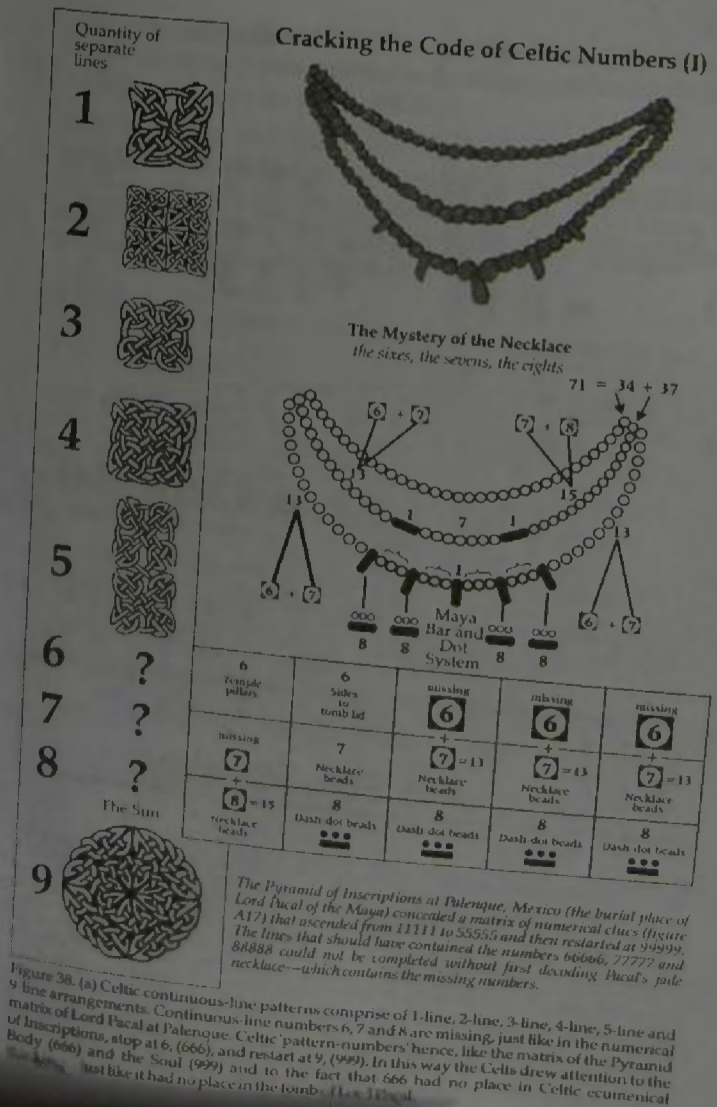

Cracking the Code of Celtic Numbers (I)

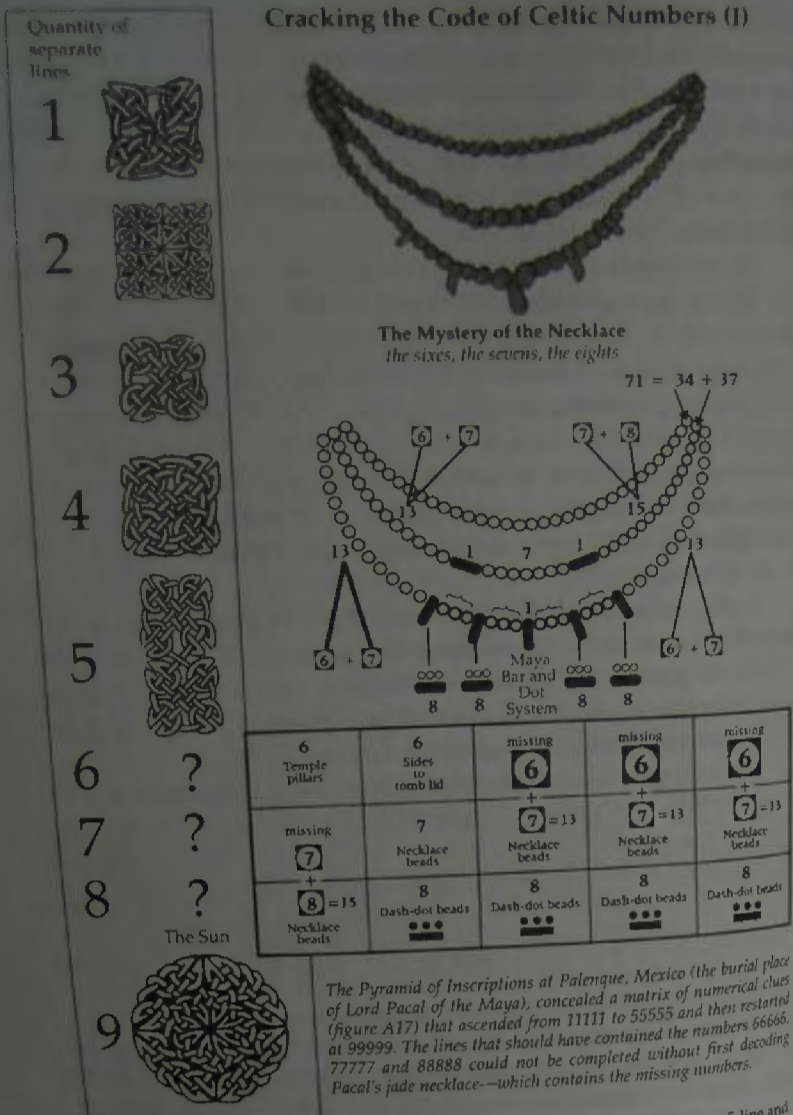

Figure 38. (a) Celtic continuous-line patterns consist of 1-line, 2-line, 3-line, 4-line, 5-line and 9-line arrangements. Continuous-line numbers 6, 7 and 8 are missing, just like in the numerical matrix of Lord Pacal at Palenque. Celtic 'pattern-numbers' hence, like the matrix of the Pyramid of Inscriptions, stop at 6 (666) and restart at 9 (999). In this way the Celts drew attention to the Body (666) and the Soul (999) and to the fact that 666 had no place in Celtic ecumenical thinking—just like it had no place in the tomb of Lord Pacal.

when the missing numbers of 678 are subtracted from the number of the body [666] (figure 39a), the result is -012. When the mirror image [representing the Soul] of the missing numbers (876) is subtracted from the number of the soul [999], the result is +123. This immediately tells us that the body (-) is of the opposite polarity [voltage] as the soul (+) as earlier hypothesised in the Theory of Iterative Spiritual Redemption (figure A20).

Continuing the resulting numerical series: 012, 123... produces the number 234. The same sequence of 234 was also found in the troop formations of Pit number 3 of Ch'in Shi Huangdi's terracotta army in China [there were 2 troops in one chamber, 3 troops in another, and 4 troops in another when read according to instructions in the tomb]. In that case it was followed by a zero [there were no troops in the north-east corner of the chamber]. Here again we have the same sequence 234 followed by nothing, giving 2340. 2,340 revolutions of the planet Venus (seen from Earth) of 584 days = 1,366,560 days—the Maya Birth of Venus number which recognises that Lord Pacal, like Jesus, was Venus.

The illuminated manuscripts of the Celts thus contain the super-science of the Sun and the higher orders of spirituality. There are other, lesser-known illuminated works, not yet mentioned; the Celtic missionary St Willibrord embarked on an evangelic mission to the Frisian Islands, off northwest Holland, in AD 690 and was appointed archbishop there in AD 695. Three years later he founded a monastery at Echternach, Luxembourg, where monks at the scriptoria made copies of illuminated manuscripts. One of these was the Echternach Gospels. The colophon says the text was copied from an original that had been revised in AD 558 by Eugippius, the abbot of a monastery near Naples.

The Lichfield Gospels was produced in around AD 740, between the appearance of the books of Lindisfarne (in AD 698) and Kells (c. AD 795). It is not known where it was written but an inscription at the end of St Matthew's Gospel reads:

Gelhi the son of Arihtuid brought this Gospel from Cingal and gave him his best horse for it... and Gelhi donated his purchase to the church of Llandeilo Fawr [in South Wales].

by the Maya [20 days, 260 days, 360 days, 7,200 days and 144,000 days] throws up the Birth of Venus number, 1,366,560 days.

Figure 38 likewise shows that the Celts encoded the same information into their knot-work numbering system and the analysis may be continued to reveal the same and additional information (figure 39); when the missing numbers of 678 are subtracted from the number of the body [666] (figure 39a) the result is -012. When the mirror image [representing the Soul] of the missing numbers (876) is subtracted from the number of the soul [999] the result is +123. This immediately tells us that the body (-) is of the opposite polarity [voltage] as the soul (+) as earlier hypothesised in the Theory of Iterative Spiritual Redemption (figure A20).

Continuing the resulting numerical series: 012, 123... produces the number 234. The same sequence of 234 was also found in the troop formations of Pit number 3 of Ch'in Shi Huangdi's terracotta Army in China [there were 2 troops in one chamber, 3 troops in another, and 4 troops in another when read according to instructions in the tomb]. In that case it was followed by a zero [there were no troops in the north-east corner of the chamber]. Here again we have the same sequence 234 followed by nothing, giving 2340. 2,340 revolutions of the planet Venus (seen from Earth) of 584 days = 1,366,560 days—the Maya Birth of Venus number which recognises that Lord Pacal, like Jesus, was Venus.

The illuminated manuscripts of the Celts thus contain the super-science of the Sun and the higher orders of spirituality. There are other lesser-known illuminated works, not yet mentioned; the Celtic missionary St Willibrord embarked on an evangelical mission to the Frisian Islands, off north-west Holland, in AD 690 and was appointed Archbishop there in AD 695. Three years later he founded a monastery at Echternach, Luxembourg, where monks at the scriptoria made copies of illuminated manuscripts. One of these was the Echternach Gospels. The colophon says that the text was copied from an original that had been revised in AD 558 by Eugippius, the Abbot of a monastery near Naples.

The Lichfield Gospels was produced in around AD 740, between the appearance of the books of Lindisfarne (in AD 698) and Kells (c. AD 795). It is not known where it was written but an inscription at the end of St Matthew's Gospel reads:

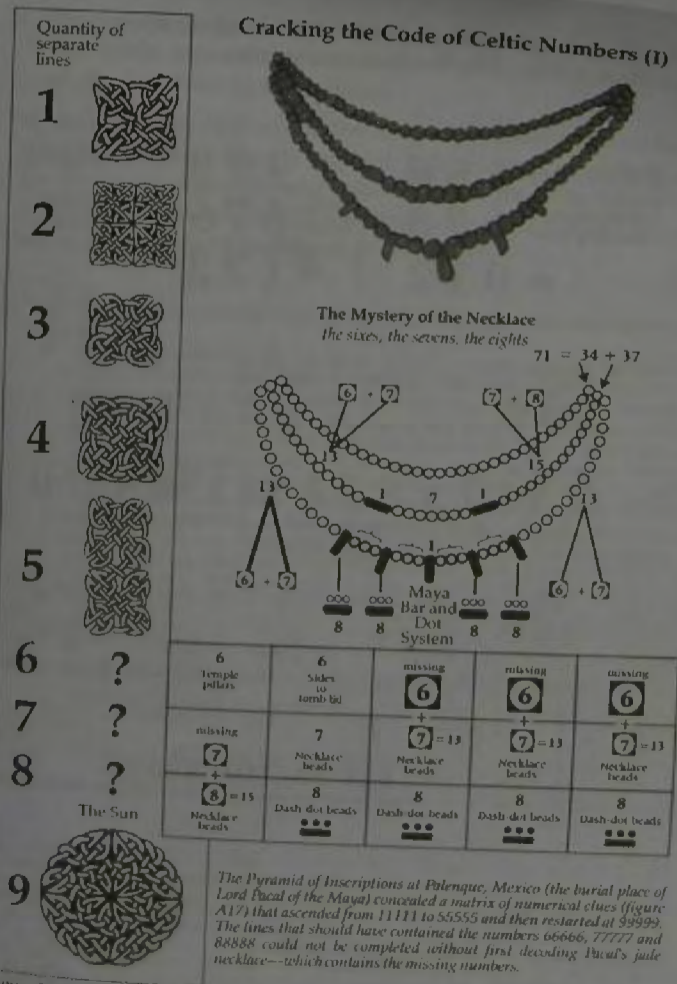

Figure 38. (a) Celtic continuous-line patterns comprise of 1-line, 2-line, 3-line, 4-line, 5-line and 9-line arrangements. Continuous-line numbers 6, 7 and 8 are missing, just like in the numerical matrix of Lord Pacal at Palenque. Celtic 'pattern-numbers' hence, like the matrix of the Pyramid of Inscriptions, stop at 6 (666) and restart at 9 (999). In this way the Celts drew attention to the Body (666) and the Soul (999) and to the fact that 666 had no place in Celtic ecumenical thinking—just like it had no place in the tomb of Lord Pacal.

(a)	Number of the body	6 6 6	Number of the soul	9 9 9
	Missing numbers ascending order	6 7 8	Mirror Image	8 7 6
(c)		- 0 1 2		+ 1 2 3

Next in sequence =

(d) 234

(e) $2340 \times 584 = 1366560$
 Venus Interval Birth of Venus number

(f)	9 Bottom steps of pyramid	9 Pyramid levels	9 Top steps of pyramid	9 Lords painted on tomb walls	9/9* Codes on left/right sides of lid
Decoding in relation to calendar cycles used by the Maya	$9 \times 144,000 + 9 \times 7,200 + 9 \times 360 + 9 \times 260 + 9 \times 20$ = 1,366,560 days				

Figure 39. The numbers 6, 7 and 8 are missing from the Celtic numerical sequence (figure 38). The Celtic number sequence stops at 6 (666—representing the body) and restarts at 9 (999—representing the soul). (a) When the soul is in the body (666) its voltage is able to increase (represented by the ascending numbers that are missing: 6, 7, 8). (b) When the soul is in Heaven (999) its voltage can only ever decrease (if it returns to Earth) (represented by the descending missing numbers: 8, 7, 6). When the missing numbers and the mirror image (the soul) of the missing numbers are subtracted from the body and soul (c) the sequences of -012 and +123 appear, indicating, firstly, that the voltage of the body is negative (-) and that the voltage of the soul is positive (+). Secondly, continuing this new series of numbers produces the sequence 234. (d) 234 is significant because (e) 2,340 revolutions of the planet Venus amount to the Birth of Venus number worshipped by the Maya, 1366560, the same figure produced in the numerical matrix (f) from the Temple of Inscriptions, Palenque. The same number, 2340, was encoded into the arrangement of terracotta warriors in Pit number 3, at Xian, by the first emperor of China, Ch'in Shi Huangdi [the Son of Heaven—see *The Terracotta Warriors*].

(a)	Number of the body	6 6 6	Number of the soul	9 9 9
	Missing numbers ascending order	6 7 8	Mirror Image	8 7 6
(c)		- 0 1 2		+ 1 2 3

Next in sequence =

(d) 234

(e) $2340 \times 584 = 1366560$
 Venus Interval Birth of Venus number

(f)	9 Bottom steps of pyramid	9 Pyramid levels	9 Top steps of pyramid	9 Lords painted on tomb walls	9/9* Codes on left/right sides of lid
Decoding in relation to calendar cycles used by the Maya	$9 \times 144,000 + 9 \times 7,200 + 9 \times 360 + 9 \times 260 + 9 \times 20$ = 1,366,560 days				

Figure 39. The numbers 6, 7 and 8 are missing from the Celtic numerical sequence (figure 38). The Celtic number sequence stops at 6 (666—representing the body) and restarts at 9 (999—representing the soul). (a) When the soul is in the body (666) its voltage is able to increase (represented by the ascending numbers that are missing: 6, 7, 8). (b) When the soul is in Heaven (999) its voltage can only ever decrease (if it returns to Earth) (represented by the descending missing numbers: 8, 7, 6). When the missing numbers and the mirror image (the soul) of the missing numbers are subtracted from the body and soul (c) the sequences of -012 and +123 appear, indicating, firstly, that the voltage of the body is negative (-) and that the voltage of the soul is positive (+). Secondly, continuing this new series of numbers produces the sequence 234. (d) 234 is significant because (e) 2,340 revolutions of the planet Venus amount to the Birth of Venus number worshipped by the Maya, 1366560, the same figure produced in the numerical matrix (f) from the Temple of Inscriptions, Palenque. The same number, 2340, was encoded into the arrangement of terracotta warriors in Pit number 3, at Xian, by the first emperor of China, Ch'in Shi Huangdi [the Son of Heaven—see *The Terracotta Warriors*].

By the tenth century the considerably damaged book had found its way into the hands of St Chad at Lichfield. It has much in common with the Book of Lindisfarne—for example, in the layout of the carpet page and the Apostles' symbols, but the style of the Apostolic portraits are more in keeping with those from the Book of Kells.

Gelhi the son of Arihtuid brought this Gospel from Cingal and gave him his best horse for it...and Gelhi donated his purchase to the church of Llandeilo Fawr [in South Wales].

By the tenth-century the considerably damaged book had found its way into the hands of St Chad at Lichfield. It shares much in common with the Book of Lindisfarne, for example in the layout of the Carpet Page and the Apostles symbols, but the style of the Apostolic portraits are more in keeping with those from the Book of Kells.

- Notes:
- 39 So-called because the first letter of each column was often 'illuminated' in red, *ruber* (Latin).
 - 40 Easter, commemorating the Crucifixion of Jesus, coincides with the Jewish festival of Passover. The so-called 'Easter Controversy' refers to the dispute concerning the preferred dating of the Easter festival. The Jews calculate the date of Passover as occurring on a full moon. Christians knew only that the Crucifixion coincided with Passover and that it occurred at some time after the Spring equinox (the 21st March) and on a Sunday. In order to ascertain a date for Easter the Christians therefore had to synthesise the days and dates of Passover, the full moon, the Spring Equinox and the day of Sunday. This means that Easter Sunday falls on the first Sunday following the full moon that follows the Spring Equinox, meaning that Easter falls on a different date every year. The Irish Celts had their own way of doing the calculation but fell into line in AD 632. Northumbria (Lindisfarne) conformed in AD 664. Iona in AD 716 and the Welsh Church by AD 788.
 - 41 However an account from Prosper of Aquitaine's reliable *Chronicon* of AD 431 says that 'Pope Celestine ordained Palladius sending him to the Irish believers in Christ as their first Bishop... Later writers, such as Muirchu, anxious to respect Palladius, yet wishing to present Patrick as the first Bishop, imagined Palladius falling in his task, being succeeded by Patrick, hence the dating of Patrick's arrival [as Bishop] at AD 432' (quoted from *The Encyclopedia of Ireland*, Gill & Macmillan, 2003).

(a)	Number of the body	6 6 6	(b)	Number of the soul	9 9 9
	Missing numbers ascending order	6 7 8	Mirror Image	Missing numbers descending order	8 7 6
(c)		- 0 1 2			+ 1 2 3

Next in sequence =

(d) 234

(e) $2340 \times 584 = 1366560$
 Venus Interval Birth of Venus number

(f)	9 Bottom steps of pyramid	9 Pyramid levels	9 Top steps of pyramid	9 Lords painted on tomb walls	9/9* Codes on left/right sides of lid
Decoding in relation to calendar cycles used by the Maya	$9 \times 144,000 +$	$9 \times 7,200 +$	$9 \times 360 +$	$9 \times 260 +$	9×20
	= 1,366,560 days				

Figure 39. The numbers 6, 7 and 8 are missing from the Celtic numerical sequence (figure 38). The Celtic number sequence stops at 6 (666—representing the body) and restarts at 9 (999—representing the soul). (a) When the soul is in the body (666) its voltage is able to increase (represented by the ascending numbers that are missing: 6, 7, 8). (b) When the soul is in Heaven (999) its voltage can only ever decrease [if it returns to Earth] (represented by the descending missing numbers: 8, 7, 6). When the missing numbers, and the mirror image (the soul) of the missing numbers, are subtracted from the body and soul (c) the sequences of -012 and +123 appear, indicating, firstly, that the voltage of the body is negative (-) and that the voltage of the soul is positive (+). Secondly, continuing this new series of numbers produces the sequence 234. (d) 234 is significant because (e) 2,340 revolutions of the planet Venus amount to the Birth of Venus number worshipped by the Maya, 1366560, the same figure produced in the numerical matrix (f) from the Temple of Inscriptions, Palenque. The same number, 2340, was encoded into the arrangement of terracotta warriors in Pit number 3, at Xian, by the first emperor of China, Ch'in Shi Huangdi [the Son of Heaven—see *The Terracotta Warriors*].

By the tenth century the considerably damaged book had found its way into the hands of St Chad at Lichfield. It has much in common with the Book of Lindisfarne—for example, in the layout of the carpet page and the Apostles' symbols, but the style of the Apostolic portraits are more in keeping with those from the Book of Kells.

Cracking the Code of Celtic Numbers (II)
The Secrets of Reincarnation

(a)	Number of the body	6 6 6	(b)	Number of the soul	9 9 9
	Missing numbers ascending order	6 7 8	Mirror Image	Missing numbers descending order	8 7 6
(c)		- 0 1 2			+ 1 2 3

Next in sequence =

(d) 234

(e) $2340 \times 584 = 1366560$
 Venus Interval Birth of Venus number

(f)	9 Bottom steps of pyramid	9 Pyramid levels	9 Top steps of pyramid	9 Lords painted on tomb walls	9/9* Codes on left/right sides of lid
Decoding in relation to calendar cycles used by the Maya	$9 \times 144,000 +$	$9 \times 7,200 +$	$9 \times 360 +$	$9 \times 260 +$	9×20
	= 1,366,560 days				

Figure 39. The numbers 6, 7 and 8 are missing from the Celtic numerical sequence (figure 38). The Celtic number sequence stops short of 6 (666—representing the body) and restarts at 9 (999—representing the soul). (a) When the soul is in the body (666) its voltage is able to increase (represented by the ascending numbers that are missing: 6, 7, 8). (b) When the soul is in Heaven (999) its voltage can only ever decrease [if it returns to Earth] (represented by the descending missing numbers: 8, 7, 6). When the missing numbers, and the mirror image (the soul) of the missing numbers, are subtracted from the body and soul (c) the sequences of -012 and +123 appear, indicating, firstly, that the voltage of the body is negative (-) and that the voltage of the soul is positive (+). Secondly, continuing this new series of numbers produces the sequence 234. (d) 234 is significant because (e) 2,340 revolutions of the planet Venus amount to the Birth of Venus number worshipped by the Maya, 1366560, the same figure produced in the numerical matrix (f) from the Temple of Inscriptions, Palenque. The same number, 2340, was encoded into the arrangement of terracotta warriors in Pit number 3, at Xian, by the First Emperor of China, Ch'in Shi Huangdi [the Son of Heaven—see *The Terracotta Warriors*].

Gelhi the son of Arihtuid brought this Gospel from Cingal and gave him his best horse for it... and Gelhi donated his purchase to the church of Llandeilo Fawr [in South Wales].

By the tenth-century the considerably damaged book had found its way into the hands of St Chad at Lichfield. It shares much in common with the Book of Lindisfarne, for example in the layout of the Carpet Page and the Apostles symbols, but the style of the Apostolic portraits are more in keeping with those from the Book of Kells.

Notes:

- 39 So-called because the first letter of each column was often 'illuminated' in red, *ruber* (Latin).
- 40 Easter, commemorating the Crucifixion of Jesus, coincides with the Jewish festival of Passover. The so-called 'Easter Controversy' refers to the dispute concerning the preferred dating of the Easter festival. The Jews calculate the date of Passover as occurring on a full moon. Christians knew only that the Crucifixion coincided with Passover and that it occurred at some time after the Spring equinox (the 21st March) and on a Sunday. In order to ascertain a date for Easter the Christians therefore had to synthesise the days and dates of Passover, the full moon, the Spring Equinox and the day of Sunday. This means that Easter Sunday falls on the first Sunday following the full moon that follows the Spring Equinox, meaning that Easter falls on a different date every year. The Irish Celts had their own way of doing the calculation but fell into line in AD 632. Northumbria (Lindisfarne) conformed in AD 664. Iona in AD 716 and the Welsh Church by AD 768.
- 41 However an account from Prosper of Aquitaine's reliable *Chronicon* of AD 431 says that 'Pope Celestine ordained Palladius sending him to the Irish believers in Christ as their first Bishop... Later writers, such as Muirchu, anxious to respect Palladius, yet wishing to present Patrick as the first Bishop, imagined Palladius falling in his task, being succeeded by Patrick, hence the dating of Patrick's arrival [as Bishop] at AD 432' (quoted from *The Encyclopaedia of Ireland*, Gill & Macmillan, 2003).

CHAPTER FOUR

A Land Without a King

The Arthurian Legends

The period following the exodus of the Romans and the arrival of the Anglo-Saxons in Britain was one of turmoil. Their departure gave way to a free-for-all where the Angles and Saxons routed the southeast of England and it was during these so-called 'dark ages' that the legendary figure of King Arthur emerged.

It is not known for certain if Arthur was a warrior-king as he is portrayed. The earliest mention of him comes from the sixth-century writer Gildas who credits him with a victory in c. AD 500 at the battle of Mons Badonicus (Mount Badon) where a confederation of British kings fought and beat the Saxons, a victory that led to fifty years of peace. But no one knows where the battle took place, nor who fought it nor, give or take fifty years, when it was fought: only that a victory of the kind had been won.

In the ninth century the monk Nennius describes twelve of Arthur's battles in his *History of Britain*. But again no hard evidence exists to substantiate the accounts. Nennius describes Arthur as a *dux bellorum*, a Romano-British cavalry commander who must have lived, therefore, at least fifty years earlier [c. AD 450] before the arrival of the Saxons. A seventh-century Welsh poem, *The Book of Aneirin*, describes Arthur, historically, as a great warrior.

The legends of Arthur appeared in the twelfth-century works of the French writer Chrétien (Christian) de Troyes, Geoffrey of Monmouth, and in the fifteenth-century work of the English author Thomas Malory.

CHAPTER FOUR

A Land Without a King

The Arthurian Legends

The period following the exodus of the Romans and the arrival of the Anglo-Saxons in Britain was one of turmoil. Their departure gave way to a free-for-all where the Angles and Saxons routed the Southeast of England and it was during these so-called 'dark-ages' that the legendary figure of King Arthur emerged.

It is not known for certain if Arthur was a warrior-king as he is portrayed. The earliest mention of him comes from the sixth-century writer Gildas who credits him with a victory in c. AD 500 at the battle of Mons Badonicus (Mount Badon) where a confederation of British kings fought and beat the Saxons, a victory that led to 50 years of peace. But no one knows where the battle took place, nor who fought it nor, give or take 50-years, when it was fought: only that a victory of the kind had been won.

In the ninth century the monk Nennius describes 12 of Arthur's battles in his *History of Britain*. But again no hard evidence exists to substantiate the accounts. Nennius describes Arthur as a *dux bellorum*, a Romano-British cavalry commander who must have lived, therefore, at least 50 years earlier [c. AD 450] before the arrival of the Saxons. A seventh-century Welsh poem, *The Book of Aneirin*, describes Arthur, historically, as a great warrior.

Arthur is believed to have been born at Tintagel Castle in Cornwall and eventually buried at Glastonbury Church.

Chrétien de Troyes wrote several accounts of the Arthurian legends: *Perceval ou le conte du Graal* (c. 1182), *Lancelot, ou le Chevalier de la Charrette* (c. 1178), *Erec* (c. 1170) and *Yvain, ou le Chevalier au Lion* (c. 1178).

In *Perceval ou le conte du Graal* the hero, a young knight named Perceval, chances upon a mysterious castle near a river. The lord of the castle is known as the Fisher King, ostensibly because he is crippled and therefore incapable of walking or running and able only to fish. Inside the castle Perceval beholds a vision of a procession led by a young man carrying a white lance that drips blood onto his hands. He is followed by two men carrying candelabra and a beautiful girl who carries the Holy Grail, or *Sang Royal* (French for *Holy Blood of Christ*) in a cup. The light from the cup illuminates the whole room. A maiden carrying a carving dish is the last in the line. The procession moves past Perceval and out of the room. Perplexed, he fails to enquire who or what the procession was meant to represent. When he rises the next day the castle is deserted and as he attempts to leave the drawbridge rises by itself. He survives the ordeal and is later told that he should have asked the question 'whom does the Grail serve?' If he had asked the question then the Fisher King would have been cured and could have walked again.

This version of the Grail differs substantially from the others. This one, in isolation, appears to be an allegorical tale about Christ, the Fisher King who is symbolised by the sign of the fish, the vesica pisces, the geometric symbol of Christianity which is constructed from two overlapping circles (plate 3) that represent the twin planet Venus (plate 3c). The blood dripping from the lance likely represents the sword of the Roman soldier Longinus who pierced the side of Christ on the Cross and thus had 'blood on his hands'. The candelabra carriers represent those who seek the light and the beautiful girl takes the part of Salome, the daughter of King Heroditus Antipas who demanded and received the head of John the Baptist on a silver plate:

And when Salome, the daughter of Heroditus had come in, and had danced, and pleased Herod and them that were at table with him, the king said to the damsel: Ask of me what thou wilt, and I will give it thee. . . . Who when she was gone out, said to her mother,

The legends of Arthur appeared in the twelfth-century works of the French writer Chrétien (Christian) de Troyes, Geoffrey of Monmouth, and in the fifteenth-century work of the English author Thomas Malory. Arthur is believed to have been born at Tintagel Castle in Cornwall and eventually buried at Glastonbury Church.

Chrétien de Troyes wrote several accounts of the Arthurian legends: *Perceval ou le conte du Graal* (c. 1182), *Lancelot, ou le Chevalier de la Charrette* (c. 1178), *Erec* (c. 1170) and *Yvain, ou le Chevalier au Lion* (c. 1178).

In *Perceval ou le conte du Graal* the hero, a young knight named Perceval, chances upon a mysterious castle near a river. The Lord of the castle is known as the Fisher King, ostensibly because he is crippled and therefore incapable of walking or running and able only to fish. Inside the castle Perceval beholds a vision of a procession led by a young man carrying a white lance that drips blood on to his hands. He is followed by two men carrying candelabra and a beautiful girl who carries the Holy Grail, or *Sang Royal* (French for *Holy Blood of Christ*) in a cup. The light from the cup illuminates the whole room. A maiden carrying a carving dish is the last in the line. The procession moves past Perceval and out of the room. Perplexed, he fails to enquire who or what the procession was meant to represent. When he rises the next day the castle is deserted and as he attempts to leave, the drawbridge rises by itself. He survives the ordeal and is later told that he should have asked the question 'whom does the Grail serve?' If he had asked the question then the Fisher King would have been cured and could have walked again.

This version of the Grail differs substantially from the others. This one, in isolation, appears to be an allegorical tale about Christ, the Fisher King who is symbolised by the sign of the fish, the vesica pisces, the geometric symbol of Christianity which is constructed from two overlapping circles (plate 3) that represent the twin planet Venus (plate 3c). The blood dripping from the lance likely represents the sword of the Roman soldier Longinus who pierced the side of Christ on the Cross and thus had 'blood on his hands'. The candelabra carriers represent those who seek the light and the beautiful girl takes the part of Salome, the daughter of King Heroditus Antipas who demanded and received the head of John the Baptist on a silver plate;

And when Salome, the daughter of Heroditus had come in, and had

A Land Without a King

The Arthurian Legends

The period following the exodus of the Romans and the arrival of the Anglo-Saxons in Britain was one of turmoil. Their departure gave way to a free-for-all where the Angles and Saxons routed the southeast of England and it was during these so-called 'dark ages' that the legendary figure of King Arthur emerged.

It is not known for certain if Arthur was a warrior-king as he is portrayed. The earliest mention of him comes from the sixth-century writer Gildas who credits him with a victory in c. AD 500 at the battle of Mons Badonicus (Mount Badon) where a confederation of British kings fought and beat the Saxons, a victory that led to fifty years of peace. But no one knows where the battle took place, nor who fought it nor, give or take fifty years, when it was fought: only that a victory of the kind had been won.

In the ninth century the monk Nennius describes twelve of Arthur's battles in his *History of Britain*. But again no hard evidence exists to substantiate the accounts. Nennius describes Arthur as a *dux bellorum*, a Romano-British cavalry commander who must have lived, therefore, at least fifty years earlier [c. AD 450] before the arrival of the Saxons. A seventh-century Welsh poem, *The Book of Aneirin*, describes Arthur, historically, as a great warrior.

The legends of Arthur appeared in the twelfth-century works of the French writer Chrétien (Christian) de Troyes, Geoffrey of Monmouth, and in the fifteenth-century work of the English author Thomas Malory.

A Land Without a King

The Arthurian Legends

The period following the exodus of the Romans and the arrival of the Anglo-Saxons in Britain was one of turmoil. Their departure gave way to a free-for-all where the Angles and Saxons routed the Southeast of England and it was during these so-called 'dark-ages' that the legendary figure of King Arthur emerged.

It is not known for certain if Arthur was a warrior-king as he is portrayed. The earliest mention of him comes from the sixth-century writer Gildas who credits him with a victory in c. AD 500 at the battle of Mons Badonicus (Mount Badon) where a confederation of British kings fought and beat the Saxons, a victory that led to 50 years of peace. But no one knows where the battle took place, nor who fought it nor, give or take 50-years, when it was fought; only that a victory of the kind had been won.

In the ninth-century the monk Nennius describes 12 of Arthur's battles in his *History of Britain*. But again no hard evidence exists to substantiate the accounts. Nennius describes Arthur as a *dux bellorum*, a Romano-British cavalry commander who must have lived, therefore, at least 50 years earlier [c. AD 450] before the arrival of the Saxons. A seventh-century Welsh poem, *The Book of Aneirin*, describes Arthur, historically, as a great warrior.

Arthur is believed to have been born at Tintagel Castle in Cornwall and eventually buried at Glastonbury Church.

Chrétien de Troyes wrote several accounts of the Arthurian legends: *Perceval ou le conte du Graal* (c. 1182), *Lancelot, ou le Chevalier de la Charrette* (c. 1178), *Erec* (c. 1170) and *Yvain, ou le Chevalier au Lion* (c. 1178).

In *Perceval ou le conte du Graal* the hero, a young knight named Perceval, chanced upon a mysterious castle near a river. The lord of the castle is known as the Fisher King, ostensibly because he is crippled and therefore incapable of walking or running and able only to fish. Inside the castle Perceval beholds a vision of a procession led by a young man carrying a white lance that drips blood onto his hands. He is followed by two men carrying candelabra and a beautiful girl who carries the Holy Grail, or *Sang Royal* (French for *Holy Blood of Christ*) in a cup. The light from the cup illuminates the whole room. A maiden carrying a carving dish is the last in the line. The procession moves past Perceval and out of the room. Perplexed, he fails to enquire who or what the procession was meant to represent. When he rises the next day the castle is deserted and as he attempts to leave the drawbridge rises by itself. He survives the ordeal and is later told that he should have asked the question 'whom does the Grail serve?' If he had asked the question then the Fisher King would have been cured and could have walked again.

This version of the Grail differs substantially from the others. This one, in isolation, appears to be an allegorical tale about Christ, the Fisher King who is symbolised by the sign of the fish, the vesica pisces, the geometric symbol of Christianity which is constructed from two overlapping circles (plate 3) that represent the twin planet Venus (plate 3c). The blood dripping from the lance likely represents the sword of the Roman soldier Longinus who pierced the side of Christ on the Cross and thus had 'blood on his hands'. The candelabra carriers represent those who seek the light and the beautiful girl takes the part of Salome, the daughter of King Heroditus Antipas who demanded and received the head of John the Baptist on a silver plate:

And when Salome, the daughter of Heroditus had come in, and had danced, and pleased Herod and them that were at table with him, the king said to the damsel: Ask of me what thou wilt, and I will give it thee . . . Who when she was gone out, said to her mother,

The legends of Arthur appeared in the twelfth-century works of the French writer Chrétien (Christian) de Troyes, Geoffrey of Monmouth, and in the fifteenth-century work of the English author Thomas Malory. Arthur is believed to have been born at Tintagel Castle in Cornwall and eventually buried at Glastonbury Church.

Chrétien de Troyes wrote several accounts of the Arthurian legends: *Perceval ou le conte du Graal* (c. 1182), *Lancelot, ou le Chevalier de la Charrette* (c. 1178), *Erec* (c. 1170) and *Yvain, ou le Chevalier au Lion* (c. 1178).

In *Perceval ou le conte du Graal* the hero, a young knight named Perceval, chanced upon a mysterious castle near a river. The Lord of the castle is known as the Fisher King, ostensibly because he is crippled and therefore incapable of walking or running and able only to fish. Inside the castle Perceval beholds a vision of a procession led by a young man carrying a white lance that drips blood on to his hands. He is followed by two men carrying candelabra and a beautiful girl who carries the Holy Grail, or *Sang Royal* (French for *Holy Blood of Christ*) in a cup. The light from the cup illuminates the whole room. A maiden carrying a carving dish is the last in the line. The procession moves past Perceval and out of the room. Perplexed, he fails to enquire who or what the procession was meant to represent. When he rises the next day the castle is deserted and as he attempts to leave, the drawbridge rises by itself. He survives the ordeal and is later told that he should have asked the question 'whom does the Grail serve?' If he had asked the question then the Fisher King would have been cured and could have walked again.

This version of the Grail differs substantially from the others. This one, in isolation, appears to be an allegorical tale about Christ, the Fisher King who is symbolised by the sign of the fish, the vesica pisces, the geometric symbol of Christianity which is constructed from two overlapping circles (plate 3) that represent the twin planet Venus (plate 3c). The blood dripping from the lance likely represents the sword of the Roman soldier Longinus who pierced the side of Christ on the Cross and thus had 'blood on his hands'. The candelabra carriers represent those who seek the light and the beautiful girl takes the part of Salome, the daughter of King Heroditus Antipas who demanded and received the head of John the Baptist on a silver plate:

And when Salome, the daughter of Heroditus had come in, and had

CHAPTER FOUR

A Land Without a King

The Arthurian Legends

The period following the exodus of the Romans and the arrival of the Anglo-Saxons in Britain was one of turmoil. Their departure gave way to a free-for-all where the Angles and Saxons routed the southeast of England and it was during these so-called 'dark ages' that the legendary figure of King Arthur emerged.

It is not known for certain if Arthur was a warrior-king as he is portrayed. The earliest mention of him comes from the sixth-century writer Gildas who credits him with a victory in c. AD 500 at the battle of Mons Badonicus (Mount Badon) where a confederation of British kings fought and beat the Saxons, a victory that led to fifty years of peace. But no one knows where the battle took place, nor who fought it nor, give or take fifty years, when it was fought: only that a victory of the kind had been won.

In the ninth century the monk Nennius describes twelve of Arthur's battles in his *History of Britain*. But again no hard evidence exists to substantiate the accounts. Nennius describes Arthur as a *dux bellorum*, a Romano-British cavalry commander who must have lived, therefore, at least fifty years earlier [c. AD 450] before the arrival of the Saxons. A seventh-century Welsh poem, *The Book of Aneirin*, describes Arthur, historically, as a great warrior.

The legends of Arthur appeared in the twelfth-century works of the French writer Chrétien (Christian) de Troyes, Geoffrey of Monmouth, and in the fifteenth-century work of the English author Thomas Malory.

Arthur is believed to have been born at Tintagel Castle in Cornwall and eventually buried at Glastonbury Church.

Chrétien de Troyes wrote several accounts of the Arthurian legends: *Perceval ou le conte du Graal* (c. 1182), *Lancelot, ou le Chevalier de la Charrette* (c. 1178), *Erec* (c. 1170) and *Yvain, ou le Chevalier au Lion* (c. 1178).

In *Perceval ou le conte du Graal* the hero, a young knight named Perceval, chanced upon a mysterious castle near a river. The lord of the castle is known as the Fisher King, ostensibly because he is crippled and therefore incapable of walking or running and able only to fish. Inside the castle Perceval beholds a vision of a procession led by a young man carrying a white lance that drips blood onto his hands. He is followed by two men carrying candelabra and a beautiful girl who carries the Holy Grail, or *Sang Royal* (French for *Holy Blood of Christ*) in a cup. The light from the cup illuminates the whole room. A maiden carrying a carving dish is the last in the line. The procession moves past Perceval and out of the room. Perplexed, he fails to enquire who or what the procession was meant to represent. When he rises the next day the castle is deserted and as he attempts to leave the drawbridge rises by itself. He survives the ordeal and is later told that he should have asked the question 'whom does the Grail serve?' If he had asked the question then the Fisher King would have been cured and could have walked again.

This version of the Grail differs substantially from the others. This one, in isolation, appears to be an allegorical tale about Christ, the Fisher King who is symbolised by the sign of the fish, the vesica pisces, the geometric symbol of Christianity which is constructed from two overlapping circles (plate 3) that represent the twin planet Venus (plate 3c). The blood dripping from the lance likely represents the sword of the Roman soldier Longinus who pierced the side of Christ on the Cross and thus had 'blood on his hands'. The candelabra carriers represent those who seek the light and the beautiful girl takes the part of Salome, the daughter of King Heroditus Antipas who demanded and received the head of John the Baptist on a silver plate:

And when Salome, the daughter of Heroditus had come in, and had danced, and pleased Herod and them that were at table with him, the king said to the damsel: Ask of me what thou wilt, and I will give it thee . . . Who when she was gone out, said to her mother,

CHAPTER FOUR

A Land Without a King

The Arthurian Legends

The period following the exodus of the Romans and the arrival of the Anglo-Saxons in Britain was one of turmoil. Their departure gave way to a free-for-all where the Angles and Saxons routed the Southeast of England and it was during these so-called 'dark-ages' that the legendary figure of King Arthur emerged.

It is not known for certain if Arthur was a warrior-king as he is portrayed. The earliest mention of him comes from the sixth-century writer Gildas who credits him with a victory in c. AD 500 at the battle of Mons Badonicus (Mount Badon) where a confederation of British kings fought and beat the Saxons, a victory that led to 50 years of peace. But no one knows where the battle took place, nor who fought it nor, give or take 50-years, when it was fought: only that a victory of the kind had been won.

In the ninth-century the monk Nennius describes 12 of Arthur's battles in his *History of Britain*. But again no hard evidence exists to substantiate the accounts. Nennius describes Arthur as a *dux bellorum*, a Romano-British cavalry commander who must have lived, therefore, at least 50 years earlier [c. AD 450] before the arrival of the Saxons. A seventh-century Welsh poem, *The Book of Aneirin*, describes Arthur, historically, as a great warrior.

The legends of Arthur appeared in the twelfth-century works of the French writer Chrétien (Christian) de Troyes, Geoffrey of Monmouth, and in the fifteenth-century work of the English author Thomas Malory. Arthur is believed to have been born at Tintagel Castle in Cornwall and eventually buried at Glastonbury Church.

Chrétien de Troyes wrote several accounts of the Arthurian legends: *Perceval ou le conte du Graal* (c. 1182), *Lancelot, ou le Chevalier de la Charrette* (c. 1178), *Erec* (c. 1170) and *Yvain, ou le Chevalier au Lion* (c. 1178).

In *Perceval ou le conte du Graal* the hero, a young knight named Perceval, chanced upon a mysterious castle near a river. The Lord of the castle is known as the Fisher King, ostensibly because he is crippled and therefore incapable of walking or running and able only to fish. Inside the castle Perceval beholds a vision of a procession led by a young man carrying a white lance that drips blood on to his hands. He is followed by two men carrying candelabra and a beautiful girl who carries the Holy Grail, or *Sang Royal* (French for *Holy Blood of Christ*) in a cup. The light from the cup illuminates the whole room. A maiden carrying a carving dish is the last in the line. The procession moves past Perceval and out of the room. Perplexed, he fails to enquire who or what the procession was meant to represent. When he rises the next day the castle is deserted and as he attempts to leave, the drawbridge rises by itself. He survives the ordeal and is later told that he should have asked the question 'whom does the Grail serve?' If he had asked the question then the Fisher King would have been cured and could have walked again.

This version of the Grail differs substantially from the others. This one, in isolation, appears to be an allegorical tale about Christ, the Fisher King who is symbolised by the sign of the fish, the vesica pisces, the geometric symbol of Christianity which is constructed from two overlapping circles (plate 3) that represent the twin planet Venus (plate 3c). The blood dripping from the lance likely represents the sword of the Roman soldier Longinus who pierced the side of Christ on the Cross and thus had 'blood on his hands'. The candelabra carriers represent those who seek the light and the beautiful girl takes the part of Salome, the daughter of King Heroditus Antipas who demanded and received the head of John the Baptist on a silver plate:

And when Salome, the daughter of Heroditus had come in, and had

what shall I ask? But she said: The head of John the Baptist. And when she was come in immediately with haste to the king, she asked, saying: I will that forthwith thou give me in a dish, the head of John the Baptist. And the king was struck sad. Yet because of his oath, and because of them that were with him at table, he would not displease her: but sending an executioner, he commanded that his head should be brought in a dish: and gave it to the damsel, and the damsel gave it to her mother. (Mark VII, 21-28)

Failure by Perceval to question the meaning of what he saw means that the Fisher King, Jesus [the so-called cripple], would not walk again, meaning, allegorically, that Perceval, the one who failed to ask the question, would not find the Grail, would not drink the Holy Blood, and would therefore not enable the blood of Jesus to walk (live) again.

Chrétien's account therefore allegorically attempts to propagate the story of Jesus who was anointed by John the Baptist and speared in the side with a lance. Only those who ask the right questions will find the Grail, the blood of Christ, and when they do they will find the light and meet Jesus who lives again in Heaven.

Some accounts maintain that Joseph of Arimathea used the Grail to catch the spilled blood of Christ at the Crucifixion, but no biblical texts exist to support the claim. And why would anyone carry a cup to an execution? The reference to the cup that held the blood of Christ derives from the Gospel accounts of the Last Supper:

Jesus took bread, and blessed, and brake it, and gave to them, and said, take, eat: this is my body. And he took the cup [filled with wine] and when he had given thanks, he gave it to them: and they drank of it. And he said unto them, 'this is my blood of the New Testament, which is shed for many'. (Mark XIV, 22-24)

The expression from Mark refers to the wine as blood, as in the Eucharistic [Greek, *thanksgiving*] sacrament, the most important Christian ceremony in which bread and wine—the metaphorical bones and blood of Jesus—are consumed in commemoration of his tortuous death and sacrifice.

The account of the Arthurian legend from the Welsh priest Geoffrey of Monmouth (c. 1100-1114) appears in his *History of British Kings* (c. 1139). In it he claims that his Latin version is based on a translation

THE CELTIC CHRONICLES

danced, and pleased Herod and them that were at table with him, the King said to the damsel: Ask of me what thou wilt, and I will give it thee... Who when she was gone out, said to her mother, what shall I ask? But she said: The head of John the Baptist. And when she was come in immediately with haste to the King, she asked, saying: I will that forthwith thou give me in a dish, the head of John the Baptist. And the King was struck sad. Yet because of his oath, and because of them that were with him at table, he would not displease her: but sending an executioner, he commanded that his head should be brought in a dish: and gave it to the damsel, and the damsel gave it to her mother (Mark VII. 21-28).

Failure by Percival to question the meaning of what he saw means that the Fisher King, Jesus [the so-called cripple] would not walk again; meaning, allegorically, that Perceval, the one who failed to ask the question would not find the Grail, would not drink the Holy Blood, and would therefore not enable the blood of Jesus to walk (live) again.

Chrétien de Troyes account therefore allegorically attempts to propagate the story of Jesus who was anointed by John the Baptist and speared in the side with a lance. Only those who ask the right questions will find the Grail, the blood of Christ, and when they do they will find the light and meet Jesus who lives again in Heaven.

Some accounts maintain that Joseph of Arimathea used the Grail to catch the spilled blood of Christ at the Crucifixion, but no Biblical texts exist to support the claim. And why would anyone carry a cup to an execution? The reference to the cup that held the blood of Christ derives from the Gospel accounts of the Last Supper:

Jesus took bread, and blessed, and brake it, and gave to them, and said, take, eat: this is my body. And he took the cup [filled with wine] and when he had given thanks, he gave it to them: and they drank of it. And he said unto them, 'this is my blood of the New Testament, which is shed for many' (Mark XIV, 22-24).

The expression from Mark refers to the wine as blood, as in the Eucharistic [Greek, *thanksgiving*] sacrament, the most important Christian ceremony in which bread and wine—the metaphorical bones and blood of Jesus—are consumed in commemoration of his tortuous death and sac-

from an 'older text in the British tongue' leading some to believe that it derived from an earlier Celtic version. The book includes a section on *Vita Merlini*, the fabled magician mentor of Arthur.

Merlin in Welsh Celtic myth is known as Myrddin and also Emrys, an ancient rendering of the Greek name Ambrosia (*immortal*), the food of the gods, indicating that Merlin was regarded by the Celts as an immortal or one of the gods.

According to Geoffrey of Monmouth, Merlin was the illegitimate son of a Welsh nun who was overshadowed by an angel (Merlin's father) and left with child; this is to say that Merlin's mother was a virgin and that his father was angelic energy, suggesting that Merlin must have been born through an Immaculate Conception.

Sir Thomas Malory (c. 1410-1471), a Warwickshire landowner and writer, published his *Le Morte d'Arthur* [The Death of Arthur—written in English, despite the title] in around 1485 giving his own version of many of the earlier legends of King Arthur, the Knights of the Round Table, the magical sword Excalibur and the search for the Holy Grail.

Merlin appears in Malory's version as the mentor of the warrior-king Uther Pendragon. Uther appeals to Merlin for help in battle and Merlin summons the sword Excalibur from the lake. Using the magical properties of the sword Uther rises to share power with Gorlois (the Duke of Cornwall) over the lands in the southwest of England and the two leaders meet at Tintagel Castle to celebrate the union. It is there that Uther meets Queen Igraine, Gorlois's wife. Consumed with lust and desire he vows to have her and war between Uther and Gorlois breaks out again. Uther begs Merlin to help him achieve his ambition over Igraine.

Merlin draws Gorlois from the castle allowing Uther's troops to kill him. Using trickery and deception Merlin transforms Uther into the image of Gorlois and arranges the sexual union of Uther and the Queen Igraine in a deal where Uther agrees to hand over any resulting offspring in return for the satiation of Uther's lustful desires over her. Nine months later Merlin visits Queen Igraine and collects the child—Arthur. Soon after Uther is mortally wounded in battle and as he dies he thrust his sword Excalibur into a large boulder in the forest saying 'he who draws the sword from the stone shall be [the next] King'.

Merlin passes Arthur to the noble family of Sir Ector who foster and rear the child as one of their own, for around eighteen years.

A LAND WITHOUT A KING

rifice. The account of the Arthurian legend from the Welsh priest Geoffrey of Monmouth (c. 1100-1114) appears in his *History of British Kings* (c. 1139). In it he claims that his Latin version is based on a translation from an 'older text in the British tongue' leading some to believe that it derived from an earlier Celtic version. The book includes a section on *Vita Merlini*, the fabled magician mentor of Arthur.

Merlin in Welsh Celtic myth is known as Myrddin and also Emrys, an ancient rendering of the Greek name Ambrosia (*immortal*), the food of the Gods, indicating that Merlin was regarded by the Celts as an immortal or one of the Gods.

According to Geoffrey of Monmouth, Merlin was the illegitimate son of a Welsh nun who was overshadowed by an Angel (Merlin's father) and left with child; this is to say that Merlin's mother was a virgin and that his father was angelic energy, suggesting that Merlin must have been born through an Immaculate Conception.

Sir Thomas Malory (c. 1410-1471), a Warwickshire landowner and writer, published his *Le Morte d'Arthur* [The Death of Arthur—written in English, despite the title] in around 1485 giving his own version of many of the earlier legends of King Arthur, the Knights of the Round table, the magical sword Excalibur and the search for the Holy Grail.

Merlin appears in Malory's version as the mentor of the warrior-king Uther Pendragon. Uther appeals to Merlin for help in battle and Merlin summons the sword Excalibur from a lake. Using the magical properties of the sword Uther rises to share power with Gorlois (the Duke of Cornwall) over the lands in the south-west of England and the two leaders meet at Tintagel castle to celebrate the union. It is there that Uther meets Queen Igraine, Gorlois' wife. Consumed with lust and desire he vows to have her and war between Uther and Gorlois breaks out again. Uther begs Merlin to help him achieve his ambition over Igraine.

Merlin draws Gorlois from the castle allowing Uther's troops to kill him. Using trickery and deception Merlin transforms Uther into the image of Gorlois and arranges the sexual union of Uther and the Queen Igraine in a deal where Uther agrees to hand over any resulting offspring in return for the satiation of Uther's lustful desires over her. Nine months later Merlin visits Queen Igraine and collects the child—Arthur. Soon

what shall I ask? But she said: The head of John the Baptist. And when she was come in immediately with haste to the king, she asked, saying: I will that forthwith thou give me in a dish, the head of John the Baptist. And the king was struck sad. Yet because of his oath, and because of them that were with him at table, he would not displease her: but sending an executioner, he commanded that his head should be brought in a dish: and gave it to the damsel, and the damsel gave it to her mother. (Mark VII, 21-28)

Failure by Perceval to question the meaning of what he saw means that the Fisher King, Jesus [the so-called cripple], would not walk again, meaning, allegorically, that Perceval, the one who failed to ask the question, would not find the Grail, would not drink the Holy Blood, and would therefore not enable the blood of Jesus to walk (live) again.

Chrétien's account therefore allegorically attempts to propagate the story of Jesus who was anointed by John the Baptist and speared in the side with a lance. Only those who ask the right questions will find the Grail, the blood of Christ, and when they do they will find the light and meet Jesus who lives again in Heaven.

Some accounts maintain that Joseph of Arimathea used the Grail to catch the spilled blood of Christ at the Crucifixion, but no biblical texts exist to support the claim. And why would anyone carry a cup to an execution? The reference to the cup that held the blood of Christ derives from the Gospel accounts of the Last Supper:

Jesus took bread, and blessed, and brake it, and gave to them, and said, take, eat: this is my body. And he took the cup [filled with wine] and when he had given thanks, he gave it to them: and they drank of it. And he said unto them, 'this is my blood of the New Testament, which is shed for many'. (Mark XIV, 22-24)

The expression from Mark refers to the wine as blood, as in the Eucharistic [Greek, *thanksgiving*] sacrament, the most important Christian ceremony in which bread and wine—the metaphorical bones and blood of Jesus—are consumed in commemoration of his tortuous death and sacrifice.

The account of the Arthurian legend from the Welsh priest Geoffrey of Monmouth (c. 1100-1114) appears in his *History of British Kings* (c. 1139). In it he claims that his Latin version is based on a translation

from an 'older text in the British tongue' leading some to believe that it derived from an earlier Celtic version. The book includes a section on *Vita Merlini*, the fabled magician mentor of Arthur.

Merlin in Welsh Celtic myth is known as Myrddin and also Emrys, an ancient rendering of the Greek name Ambrosia (*immortal*), the food of the gods, indicating that Merlin was regarded by the Celts as an immortal or one of the gods.

According to Geoffrey of Monmouth, Merlin was the illegitimate son of a Welsh nun who was overshadowed by an angel (Merlin's father) and left with child; this is to say that Merlin's mother was a virgin and that his father was angelic energy, suggesting that Merlin must have been born through an Immaculate Conception.

Sir Thomas Malory (c. 1410-1471), a Warwickshire landowner and writer, published his *Le Morte d'Arthur* [The Death of Arthur—written in English, despite the title] in around 1485 giving his own version of many of the earlier legends of King Arthur, the Knights of the Round Table, the magical sword Excalibur and the search for the Holy Grail.

Merlin appears in Malory's version as the mentor of the warrior-king Uther Pendragon. Uther appeals to Merlin for help in battle and Merlin summons the sword Excalibur from the lake. Using the magical properties of the sword Uther rises to share power with Gorlois (the Duke of Cornwall) over the lands in the southwest of England and the two leaders meet at Tintagel Castle to celebrate the union. It is there that Uther meets Queen Igraine, Gorlois's wife. Consumed with lust and desire he vows to have her and war between Uther and Gorlois breaks out again. Uther begs Merlin to help him achieve his ambition over Igraine.

Merlin draws Gorlois from the castle allowing Uther's troops to kill him. Using trickery and deception Merlin transforms Uther into the image of Gorlois and arranges the sexual union of Uther and the Queen Igraine in a deal where Uther agrees to hand over any resulting offspring in return for the satiation of Uther's lustful desires over her. Nine months later Merlin visits Queen Igraine and collects the child—Arthur. Soon after Uther is mortally wounded in battle and as he dies he thrust his sword Excalibur into a large boulder in the forest saying 'he who draws the sword from the stone shall be [the next] King'.

Merlin passes Arthur to the noble family of Sir Ector who foster and rear the child as one of their own, for around eighteen years.

danced, and pleased Herod and them that were at table with him, the King said to the damsel: Ask of me what thou wilt, and I will give it thee... Who when she was gone out, said to her mother, what shall I ask? But she said: The head of John the Baptist. And when she was come in immediately with haste to the King, she asked, saying: I will that forthwith thou give me in a dish, the head of John the Baptist. And the King was struck sad. Yet because of his oath, and because of them that were with him at table, he would not displease her: but sending an executioner, he commanded that his head should be brought in a dish: and gave it to the damsel, and the damsel gave it to her mother (Mark VII, 21-28).

Failure by Percival to question the meaning of what he saw means that the Fisher King, Jesus [the so-called cripple] would not walk again; meaning, allegorically, that Perceval, the one who failed to ask the question would not find the Grail, would not drink the Holy Blood, and would therefore not enable the blood of Jesus to walk (live) again.

Chrétien de Troyes account therefore allegorically attempts to propagate the story of Jesus who was anointed by John the Baptist and speared in the side with a lance. Only those who ask the right questions will find the Grail, the blood of Christ, and when they do they will find the light and meet Jesus who lives again in Heaven.

Some accounts maintain that Joseph of Arimathea used the Grail to catch the spilled blood of Christ at the Crucifixion, but no Biblical texts exist to support the claim. And why would anyone carry a cup to an execution? The reference to the cup that held the blood of Christ derives from the Gospel accounts of the Last Supper:

Jesus took bread, and blessed, and brake it, and gave to them, and said, take, eat: this is my body. And he took the cup [filled with wine] and when he had given thanks, he gave it to them: and they drank of it. And he said unto them, 'this is my blood of the New Testament, which is shed for many' (Mark XIV, 22-24).

The expression from Mark refers to the wine as blood, as in the Eucharistic [Greek, *thanksgiving*] sacrament, the most important Christian ceremony in which bread and wine—the metaphorical bones and blood of Jesus—are consumed in commemoration of his tortuous death and sac-

rifice. The account of the Arthurian legend from the Welsh priest Geoffrey of Monmouth (c. 1100-1114) appears in his *History of British Kings* (c. 1139). In it he claims that his Latin version is based on a translation from an 'older text in the British tongue' leading some to believe that it derived from an earlier Celtic version. The book includes a section on *Vita Merlini*, the fabled magician mentor of Arthur.

Merlin in Welsh Celtic myth is known as Myrddin and also Emrys, an ancient rendering of the Greek name Ambrosia (*immortal*), the food of the Gods, indicating that Merlin was regarded by the Celts as an immortal or one of the Gods.

According to Geoffrey of Monmouth, Merlin was the illegitimate son of a Welsh nun who was overshadowed by an Angel (Merlin's father) and left with child; this is to say that Merlin's mother was a virgin and that his father was angelic energy, suggesting that Merlin must have been born through an Immaculate Conception.

Sir Thomas Malory (c. 1410-1471), a Warwickshire landowner and writer, published his *Le Morte d'Arthur* [The Death of Arthur—written in English, despite the title] in around 1485 giving his own version of many of the earlier legends of King Arthur, the Knights of the Round Table, the magical sword Excalibur and the search for the Holy Grail.

Merlin appears in Malory's version as the mentor of the warrior king Uther Pendragon. Uther appeals to Merlin for help in battle and Merlin summons the sword Excalibur from a lake. Using the magical properties of the sword Uther rises to share power with Gorlois (the Duke of Cornwall) over the lands in the south-west of England and the two leaders meet at Tintagel castle to celebrate the union. It is there that Uther meets Queen Igraine, Gorlois' wife. Consumed with lust and desire he vows to have her and war between Uther and Gorlois breaks out again. Uther begs Merlin to help him achieve his ambition over Igraine.

Merlin draws Gorlois from the castle allowing Uther's troops to kill him. Using trickery and deception Merlin transforms Uther into the image of Gorlois and arranges the sexual union of Uther and the Queen Igraine in a deal where Uther agrees to hand over any resulting offspring in return for the satiation of Uther's lustful desires over her. Nine months later Merlin visits Queen Igraine and collects the child—Arthur. Soon

After Uther's death England had no king and noblemen of the times met regularly in jousting tournaments to decide who should have the title. Merlin reminds them that only 'he who draws the sword from the stone' shall be eligible to become king. Many knights try to draw the sword from the stone but all fail. Some years later Arthur journeyed to London to watch a tournament in which his guardian knight was taking part. Realising he had mislaid his sword the knight instructed Arthur to find one, whereupon Arthur effortlessly 'pulled the sword from the stone' to become King of England and, using the powers of Excalibur, the greatest warrior-king in the land.

One day Lancelot, 'the bravest knight from a land overseas', meets Arthur on a bridge that covers a stream and challenges his right to be King. A sword fight breaks out during which Lancelot questions Arthur's irrational passion saying 'who are you Sir, who will fight to the death for a stretch of road you could easily ride around?'

Using the powers of Excalibur, Arthur wins the fight but accidentally breaks the magic sword into two, effectively breaking that which legend says 'could not be broken'. Arthur, filled with remorse, recognises that the sword has been taken from him because of his own ego, pride and anger. He had misused the powers of the sword on a good man. Falling to the ground, he begs God for forgiveness and apologises to Lancelot. Merlin appears and summons a new sword from the lake and Lancelot pledges allegiance to Arthur.

This is the heyday of Arthurian rule. He marries Guinevere, the daughter of the knight Leon de Grance, and establishes a 'Round Table' of sun worship at his magnificent mediaeval castle in Camelot where fellow knights, inspired by courage, truth, duty and sacrifice, meet to enjoy the days of peace and tranquillity.

There is no consensus for the number of knights who joined Arthur at his Round Table. Malory's version gives twenty-six, representing the twenty-six-day rotation rate of the Sun's equatorial magnetic field. In other versions (plates 17 and 19) there are nine knights, the highest number that can be reached before becoming one with God.

All is well at the Round Table until Lancelot meets Guinevere. The couple fall in love and betray Arthur. Arthur, devastated, discovers them entwined. Unable to forgive them, he thrusts Excalibur into the ground next to their naked bodies, thus banishing them both from the land.

118



Plate 1. In 1994, J. P. Mallory and Victor H. Mair announced the discovery of Caucasian-type mummies—up to 4,000 years old—buried in the wastelands of China's Tarim basin in the Taklamakan Desert, the second largest desert in the world. The dry sand had perfectly preserved the bodies and the fabrics they wore: (a) Loulan mummy, known as the 'Beauty of Loulan', c. 2000 BC, from Qawrighul, Chinese Gumugou, Cherchan. (b) Fifty-five-year-old white, bearded male found near Cherchan, c. 1000 BC, buried with three females (tomb 2, Urumchi Museum). (c) Blonde-haired Zaghunluq mummy c. 1000 BC. (d) Zaghunluq baby (tomb 1) c. 1000 BC (aged around three months) wearing a dyed blue felt bonnet and a woolen shroud secured with a blue and red tie cord identical to that in (b). Blue lapis lazuli stones cover the eyes. (e) A plaid twill similar to one found near Qizilchoqa c. 1200–700 BC.

after Uther is mortally wounded in battle and as he dies he thrust his sword Excalibur into a large boulder in the forest saying 'he who draws the sword from the stone shall be [the next] King'.

Merlin passes Arthur to the noble family of Sir Ector who foster and rear the child as one of their own, for around 18 years.

After Uther's death England had no King and Nobleman of the times met regularly in jousting tournaments to decide who should have the title. Merlin reminds them that only 'he who draws the sword from the stone' shall be eligible to become King. Many knights try to draw the sword from the stone but all fail. Some years later Arthur journeyed to London to watch a tournament in which his guardian knight was taking part. Realising he had mislaid his sword the knight instructed Arthur to find one, whereupon Arthur effortlessly 'pulled the sword from the stone' to become King of England and, using the powers of Excalibur, the greatest warrior-king in the land.

One day Lancelot 'the bravest knight from a land overseas' meets Arthur on a bridge that covers a stream and challenges his right to be King. A sword-fight breaks out during which Lancelot questions Arthur's irrational passion saying 'who are you Sir, who will fight to the death for a stretch of road you could easily ride around?'

Using the powers of Excalibur Arthur wins the fight but accidentally breaks the magic sword into two, effectively breaking that which legend says 'could not be broken'. Arthur, filled with remorse, recognises that the sword has been taken from him because of his own ego, pride and anger. He had misused the powers of the sword on a good man. Falling to the ground, he begs God for forgiveness and apologises to Lancelot. Merlin appears and summons a new sword from the lake and Lancelot pledges allegiance to Arthur.

This is the heyday of Arthurian rule. He marries Guinevere, the daughter of the knight Leon de Grance and establishes a 'Round Table' of sun worship at his magnificent mediaeval castle in Camelot where fellow knights, inspired by courage, truth, duty and sacrifice, meet to enjoy the days of peace and tranquillity.

There is no consensus for the number of knights who joined Arthur at his Round Table. Malory's version gives 26, representing the 26-day rotation rate of the Sun's equatorial magnetic field. In other versions (plates

17 and 19) 9 knights are proposed, the highest number that can be reached before becoming one with God.

All is well at the Round Table until Lancelot meets Guinevere. The couple fall in love and betray Arthur. Arthur, devastated, discovers them entwined. Unable to forgive them, he thrusts Excalibur into the ground next to their naked bodies, thus banishing them both from the land.

At around the same time Arthur's evil stepsister Morgan-le-Fay seduces Arthur, using sorcery and trickery partially learned from Merlin, and becomes pregnant, in the hope of prising the crown from Arthur's lineage to her own.

Without Excalibur the land falls into decline and Arthur, depressed, sends his knights on a quest for the Holy Grail in the hope that the powers of the Grail will compensate for the loss of the sword. All of the knights search for the Grail without success and find only death. In Malory's version the knight Perceval sees the Grail but is unable to retrieve it. Following Perceval's attempt one seat is left empty at the round table, the Siege Perilous [the seat of peril]. Merlin ordains:

... in the Siege Perilous there shall no man sit therein but one, and if there be any so hardy to do it he shall be destroyed, and he that shall sit there shall have no peril.

As we have already heard, another version says that the Grail passed in a line of stewardship from Joseph of Aramathea eventually to the knight Sir Galahad who 'took our Lord's body between his hands more than 300 years after Joseph's death'.

Arthur, worn out and weary from a broken heart after years away from his beloved Guinevere, forgives her in his heart and mind. She then meets with Arthur and returns Excalibur, which she has treasured and kept safe during their years apart.

During the years of the quest Arthur's son by Morgan-le-Fay, Mordred, grows to manhood and challenges Arthur to hand over the Crown. Refusing, the two armies go into battle on Salisbury Plain where both Arthur and Mordred are mortally wounded. Two surviving knights, Lucan and Bedivere, help Arthur to a chapel by the sea. Arthur asks that Excalibur be tossed into a lake, saying, 'one day a king will come and raise the sword again'. Arthur's body is then carried to his final resting place in

After Uther's death England had no king and noblemen of the times met regularly in jousting tournaments to decide who should have the title. Merlin reminds them that only 'he who draws the sword from the stone' shall be eligible to become king. Many knights try to draw the sword from the stone but all fail. Some years later Arthur journeyed to London to watch a tournament in which his guardian knight was taking part. Realising he had mislaid his sword the knight instructed Arthur to find one, whereupon Arthur effortlessly 'pulled the sword from the stone' to become King of England and, using the powers of Excalibur, the greatest warrior-king in the land.

One day Lancelot, 'the bravest knight from a land overseas', meets Arthur on a bridge that covers a stream and challenges his right to be King. A sword fight breaks out during which Lancelot questions Arthur's irrational passion saying 'who are you Sir, who will fight to the death for a stretch of road you could easily ride around?'

Using the powers of Excalibur, Arthur wins the fight but accidentally breaks the magic sword into two, effectively breaking that which legend says 'could not be broken'. Arthur, filled with remorse, recognises that the sword has been taken from him because of his own ego, pride and anger. He had misused the powers of the sword on a good man. Falling to the ground, he begs God for forgiveness and apologises to Lancelot. Merlin appears and summons a new sword from the lake and Lancelot pledges allegiance to Arthur.

This is the heyday of Arthurian rule. He marries Guinevere, the daughter of the knight Leon de Grance, and establishes a 'Round Table' of sun worship at his magnificent mediaeval castle in Camelot where fellow knights, inspired by courage, truth, duty and sacrifice, meet to enjoy the days of peace and tranquillity.

There is no consensus for the number of knights who joined Arthur at his Round Table. Malory's version gives twenty-six, representing the twenty-six-day rotation rate of the Sun's equatorial magnetic field. In other versions (plates 17 and 19) there are nine knights, the highest number that can be reached before becoming one with God.

All is well at the Round Table until Lancelot meets Guinevere. The couple fall in love and betray Arthur. Arthur, devastated, discovers them entwined. Unable to forgive them, he thrusts Excalibur into the ground next to their naked bodies, thus banishing them both from the land.



Plate 1. In 1994, J. P. Mallory and Victor H. Mair announced the discovery of Caucasian-type mummies—up to 4,000 years old—buried in the wastelands of China's Tarim basin in the Taklamakan Desert, the second largest desert in the world. The dry sand had perfectly preserved the bodies and the fabrics they wore: (a) Loulan mummy, known as the 'Beauty of Loulan', c. 2000 BC, from Qawrighul, Chinese Gumugou, Cherchan. (b) Fifty-five-year-old white, bearded male found near Cherchan, c. 1000 BC, buried with three females (tomb 2, Urumchi Museum). (c) Blonde-haired Zaghunluq mummy c. 1000 BC. (d) Zaghunluq baby (tomb 1) c. 1000 BC (aged around three months) wearing a dyed blue felt bonnet and a woolen shroud secured with a blue and red tie cord identical to that in (b). Blue lapis lazuli stones cover the eyes. (e) A plaid twill similar to one found near Qizilchoqa c. 1200–700 BC.

upon a black background. No wonder that tradition should allege that these unerring lines should have been traced by angels (*Celtic Art—the methods of construction*, George Bain, Wm. McLellan & Son, Glasgow, 1951).

Bain sketched profusely the designs found on the standing-stones and in the manuscripts. Figure 34 shows some of the animal figures he catalogued from Scottish stones and the *Book of Kells*. His investigations are revealing. The sketch of the 'fighting dog' (figure 34, centre) from the *Book of Kells* is identical to the cast bronze ones that feature on the Basse Yutz flagons (plate 14) that date to the much earlier period of 400 BC, meaning that the beast must have been favoured by the Celts in decorative art for over 1,000 years.

He also noticed (figure 37) that the interlaced Celtic knot-work patterns fall into groups comprising of 1-line designs, 2-line designs, 3-line designs, 4-line designs, 5-line designs and 9-line designs. Curiously [at least it must have been to him] he never found any designs made up of 6 individual lines or 7, or 8, although this did not seem to trouble him. Bain must be congratulated for his incredible achievements, but it never occurred to him that the patterns might amount to Celtic representations of the numbers of 1, 2, 3, 4, 5 and 9. After all, if they did represent numbers, why would the numbers 6, 7 and 8 be missing?

To the esoteric Celt the fact that the numbers stop short of 6 and restart at 9 was important. It announced to the world that the Celts were acutely aware of the body (6) and the Soul (9) and given that the pattern for the number 9 resembles the Sun (figure 37) they must have been preoccupied with the Sun and its effects on Earth.

Figure 38 recalls a section of the numbers matrix from the Pyramid of Inscriptions at Palenque (figure A17). The numbers of 6, 7, 8 are likewise missing from the matrix and can only be found by decoding the beads in the jade necklace that adorned the neck of the dead Lord Pacal in his sarcophagus. When the beads are counted and rationalised the missing numbers appear, not as themselves but as factors of other compound numbers. The message of the matrix of Lord Pacal was hence twofold: there was no place for the number 666 in his tomb and the completed matrix (which finishes with 99999) multiplied by the cycles of time used



Plate 1. In 1994 J.P. Mallory and Victor H. Mair announced the discovery of caucasian-type mummies—up to 4,000 years old—buried in the wastelands of China's Tarim Basin in the Taklamakan desert, the second largest desert in the world. The dry sand had perfectly preserved the bodies and the fabrics they wore: (a) Loulan mummy, known as the 'Beauty of Loulan', c. 2000 BC, from Qawrighul, Chinese Gumugou, Cherchan. (b) 55-year old white, bearded, male found near Cherchan, c. 1000 BC, buried with three females (tomb 2, Urumchi Museum). (c) Blonde-haired Zaghunluq mummy c. 1000 BC. (d) Zaghunluq baby (tomb 1) c. 1000 BC (aged around 3 months) wearing a dyed blue felt bonnet and a woolen shroud secured with a blue and red tie cord identical to that in (b). Blue lapis lazuli stones cover the eyes. (e) A plaid twill similar to one found near Qizilchoqa c. 1200–700 BC.

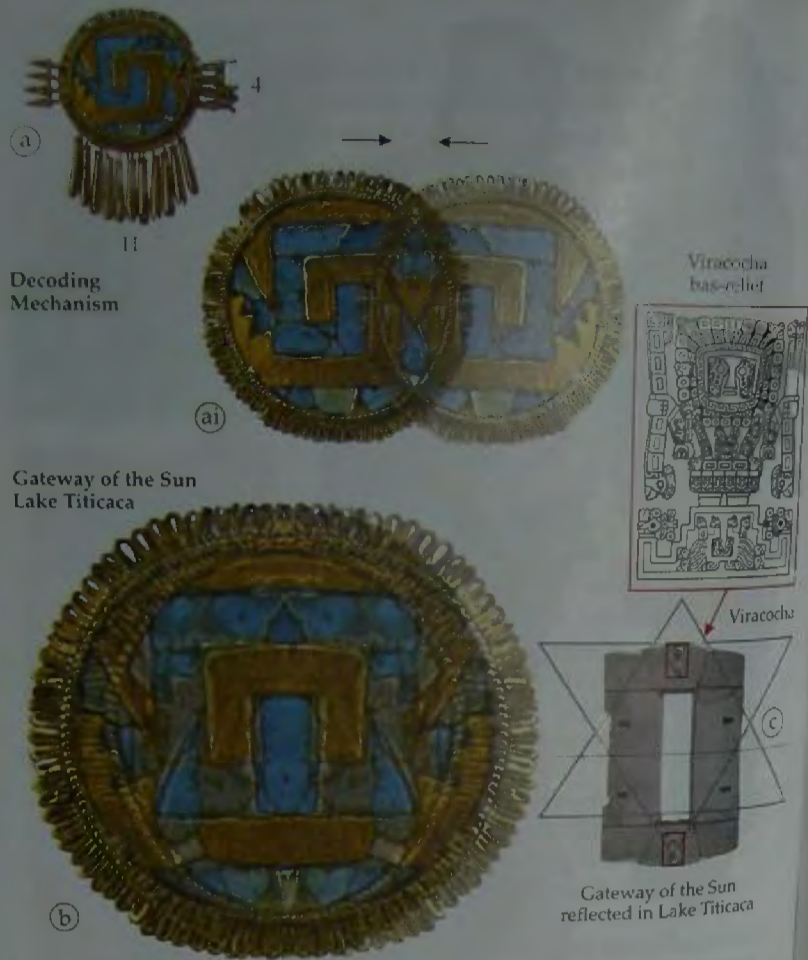

Plate 2. (a) The magnetic field of the Sun shifts every 1,366,040 days: $1,366,040 + 365.25 = 3,740$ years, exactly. This gold and turquoise sun shield from Monte Alban, Mexico, encodes this period: 4 (arrows) x 11 (pendants) x 85 (gold loops) = 3,740 [20 sunspot cycles of 187 years]. The four arrows symbolise the four previous ages of the Sun which all ended in catastrophic destruction. The 85 loops around the perimeter represent magnetic field loops of sunspots on the Sun's surface. Closer inspection of the sun shield reveals another Mayan transformer (ai) which when decoded reveals a composite picture (b) of the Gateway of the Sun at Tiahuanaco and its reflection in the waters of Lake Titicaca—all inside a Star of David, the geometric symbol of Judaism. (c) The Gateway of the Sun from Tiahuanaco, Bolivia [mirror imaged to show the reflection in the water] contained within a Star of David. Other orientations of the transparencies reveal more pictures (see plates 3 and plates 6-13). Figure 9 reveals the geometric symbolism behind the Star of David.



Plate 3. (a) Composite picture of the head and face of Viracocha. (b) Comparable picture of Lord Pacal, from the Viracocha vase of Tiahuanaco c. AD 500, Peru. (c) Composite picture of Lord Pacal, of Mexico (with the distinctive hairstyle), regurgitating a pearl [the symbol of the wisdom and the rebirth of Venus] inside a vesica pisces [the fish], the geometric symbol of Christianity. (d) Head of Lord Pacal, c. AD 750, from his tomb in the Pyramid of Inscriptions, Palenque, shown inside a vesica pisces. These secret pictures reveal that Viracocha, Lord Pacal and Christ were all different incarnations of the same spiritual energy (God) on Earth at different moments in history. [Compare (c) to the head and shoulders of Lord Pacal, appearing as Xipe Totec in the Mural of Bonampak transformer (plate 4)].

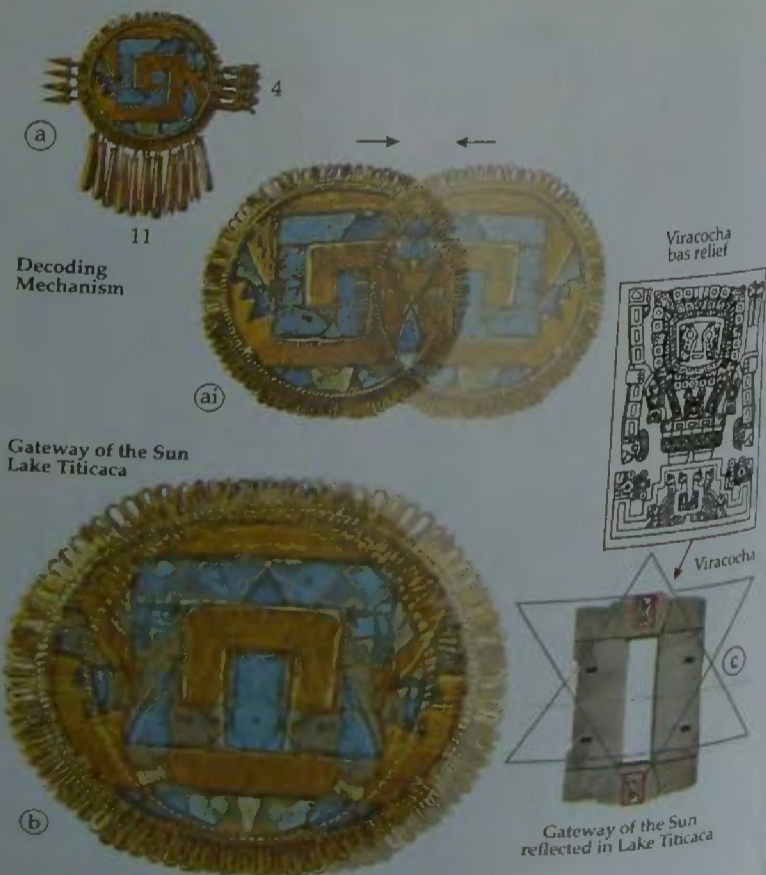

Plate 2. (a) The magnetic field of the Sun shifts every 1,366,040 days: $(1,366,040 + 365.25 = 3,740$ years, exactly). This gold and turquoise sun shield from Monte Alban, Mexico, encodes this period: 4 (arrows) x 11 (pendants) x 85 (gold loops) = 3,740 [20 sunspot cycles of 187 years]. The four arrows symbolise the four previous ages of the Sun which all ended in catastrophic destruction. The 85 loops around the perimeter represent magnetic field loops of sunspots on the Sun's surface. Closer inspection of the sun shield reveals another Maya Transformer (ai) which when decoded reveals a composite picture (b) of the Gateway of the Sun at Tiahuanaco and its reflection in the waters of Lake Titicaca—all inside a Star of David, the geometric symbol of Judaism. (c) The Gateway of the Sun from Tiahuanaco, Bolivia [mirror imaged to show the reflection in the water] contained within a Star of David. Other orientations of the transparencies reveal more pictures (see plates 3 and plates 6-13). Figure 9 reveals the geometric symbolism behind the Star of David.

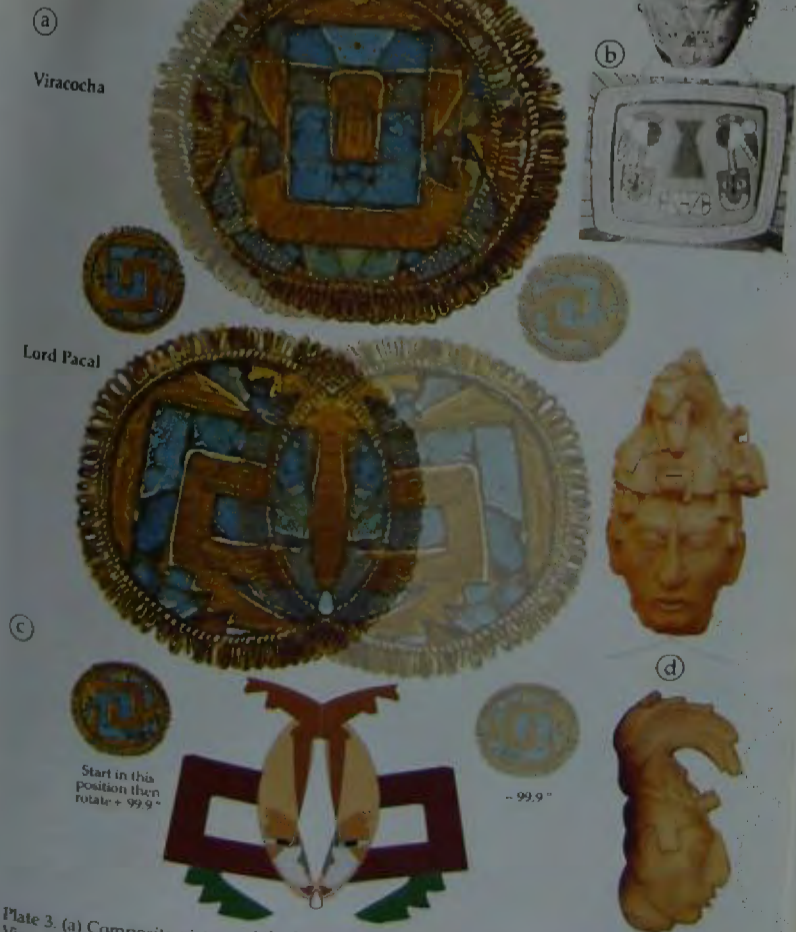

Plate 3. (a) Composite picture of the head and face of Viracocha. (b) Comparable picture of Lord Pacal, from the Viracocha vase of Tiahuanaco c. AD 500, Peru. (c) Composite picture of Lord Pacal, of Mexico (with the distinctive hairstyle), regurgitating a pearl [the symbol of the wisdom and the rebirth of Venus] inside a vesica pisces [the fish], the geometric symbol of Christianity. (d) Head of Lord Pacal, c. AD 750, from his tomb in the Pyramid of Inscriptions, Palenque, shown inside a vesica pisces. These secret pictures reveal that Viracocha, Lord Pacal and Christ were all different incarnations of the same spiritual energy (God) on Earth at different moments in history. [Compare (c) to the head and shoulders of Lord Pacal, appearing as Xipe Totec in the Mural of Bonampak transformer (plate 4)].

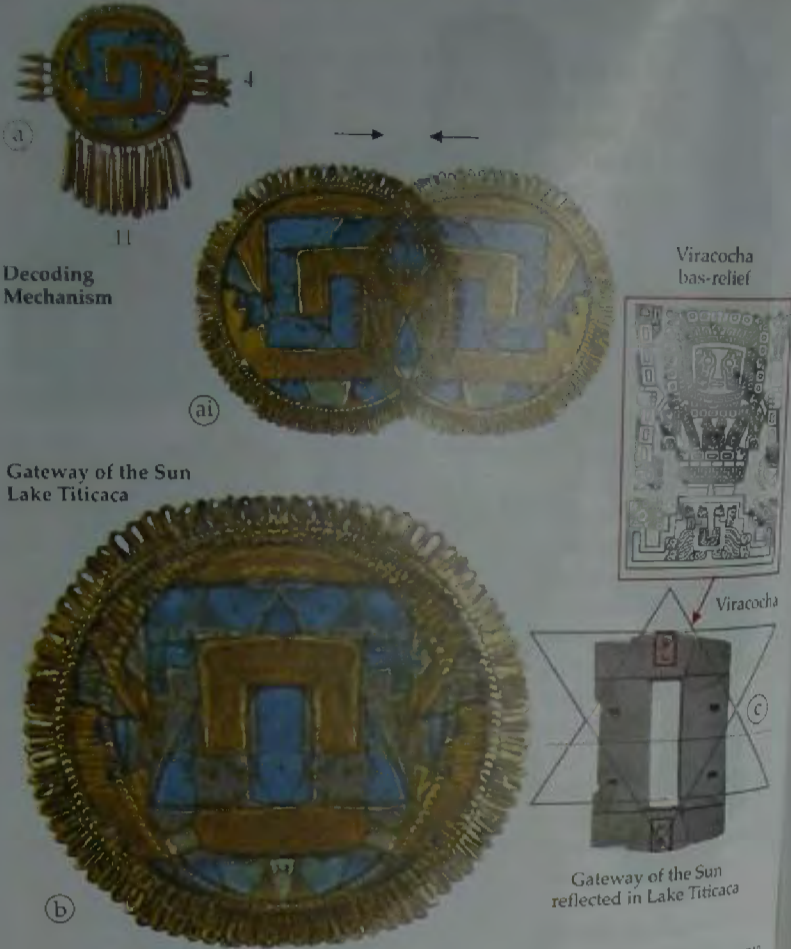

Plate 2. (a) The magnetic field of the Sun shifts every 1,366,040 days: $1,366,040 \div 365.25 = 3,740$ years, exactly. This gold and turquoise sun shield from Monte Alban, Mexico, encodes this period: 4 (arrows) \times 11 (pendants) \times 85 (gold loops) = $3,740$ [20 sunspot cycles of 187 years]. The four arrows symbolise the four previous ages of the Sun which all ended in catastrophic destruction. The 85 loops around the perimeter represent magnetic field loops of sunspots on the Sun's surface. Closer inspection of the sun shield reveals another Maya Transformer (ai) which when decoded reveals a composite picture (b) of the Gateway of the Sun at Tiahuanaco and its reflection in the waters of Lake Titicaca—all inside a Star of David, the geometric symbol of Judaism. (c) The Gateway of the Sun from Tiahuanaco, Bolivia [mirror imaged to show the reflection in the water] contained within a Star of David. Other orientations of the transparencies reveal more pictures (see plates 3 and plates 6-13). Figure 9 reveals the geometric symbolism behind the Star of David.



Plate 3. (a) Composite picture of the head and face of Viracocha. (b) Comparable picture of Viracocha, from the Viracocha vase of Tiahuanaco c. AD 500, Peru. (c) Composite picture of Lord Pacal, of Mexico (with the distinctive hairstyle), regurgitating a pearl [the symbol of the wisdom and the rebirth of Venus] inside a vesica pisces [the fish], the geometric symbol of Christianity. (d) Head of Lord Pacal, c. AD 750, from his tomb in the Pyramid of Viracocha, Palenque, shown inside a vesica pisces. These secret pictures reveal that Viracocha, Lord Pacal and Christ were all different incarnations of the same spiritual energy (God) on Earth at different moments in history. [Compare (c) to the head and shoulders of Lord Pacal, appearing as Xipe Totec in the Mural of Bonampak transformer (plate 4)].

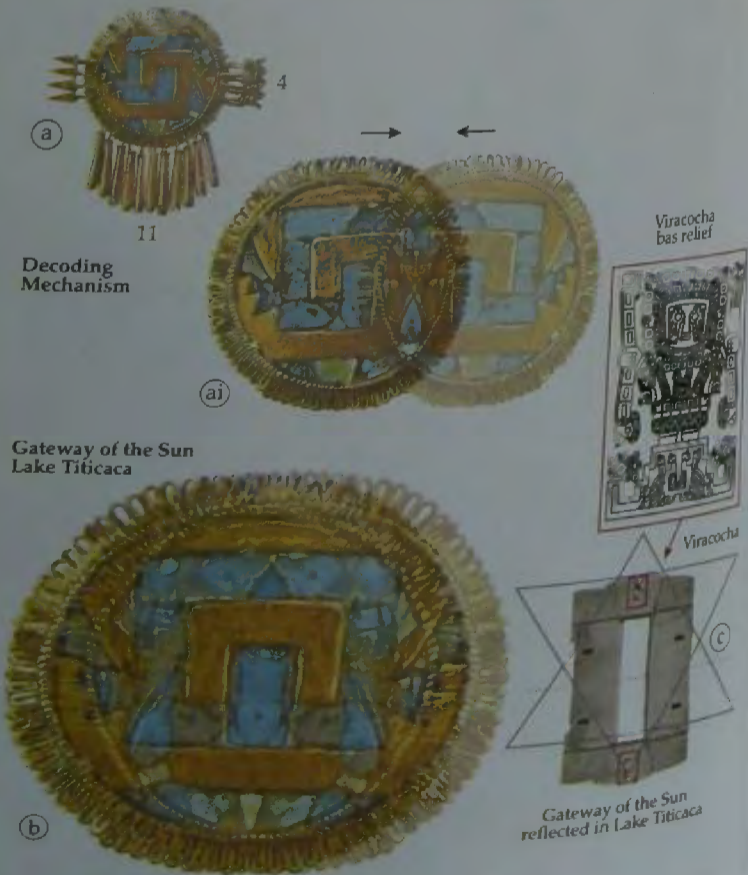

Plate 2. (a) The magnetic field of the Sun shifts every 1,366,040 days: $1,366,040 \div 365.25 = 3,740$ years, exactly. This gold and turquoise sun shield from Monte Alban, Mexico, encodes this period: 4 (arrows) \times 11 (pendants) \times 85 (gold loops) = $3,740$ [20 sunspot cycles of 187 years]. The four arrows symbolise the four previous ages of the Sun which all ended in catastrophic destruction. The 85 loops around the perimeter represent magnetic field loops of sunspots on the Sun's surface. Closer inspection of the sun shield reveals another Maya Transformer (ai) which when decoded reveals a composite picture (b) of the Gateway of the Sun at Tiahuanaco and its reflection in the waters of Lake Titicaca—all inside a Star of David, the geometric symbol of Judaism. (c) The Gateway of the Sun from Tiahuanaco, Bolivia [mirror imaged to show the reflection in the water] contained within a Star of David. (d) Other orientations of the transparencies reveal more pictures (see plates 3 and plates 6-13). Figure 9 reveals the geometric symbolism behind the Star of David.

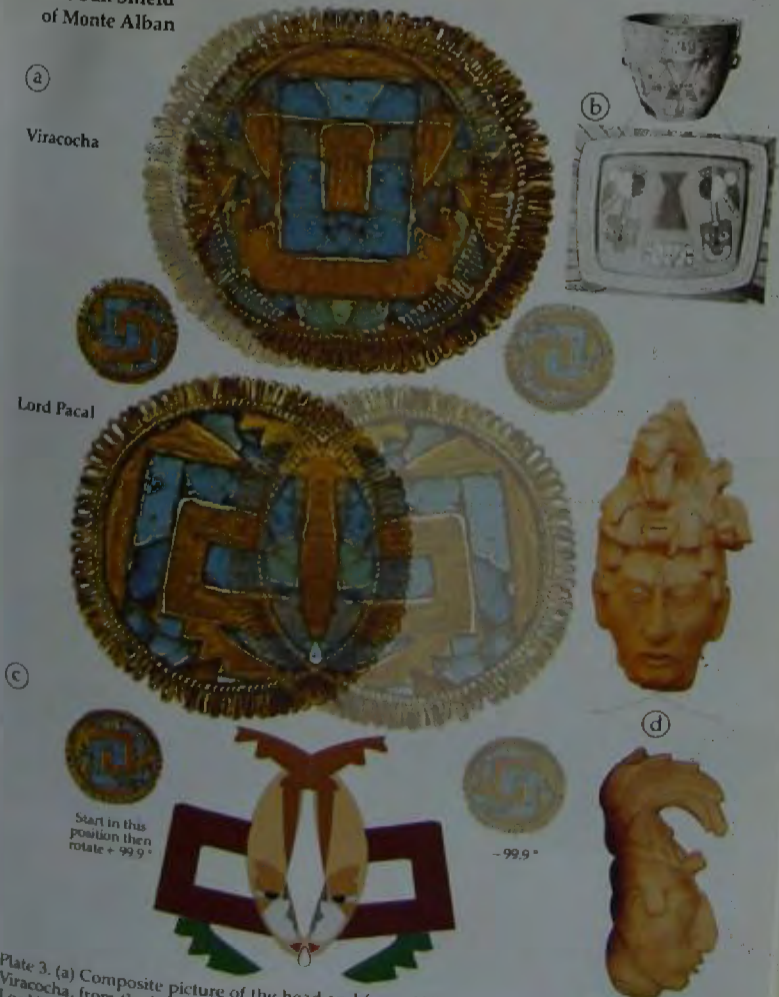
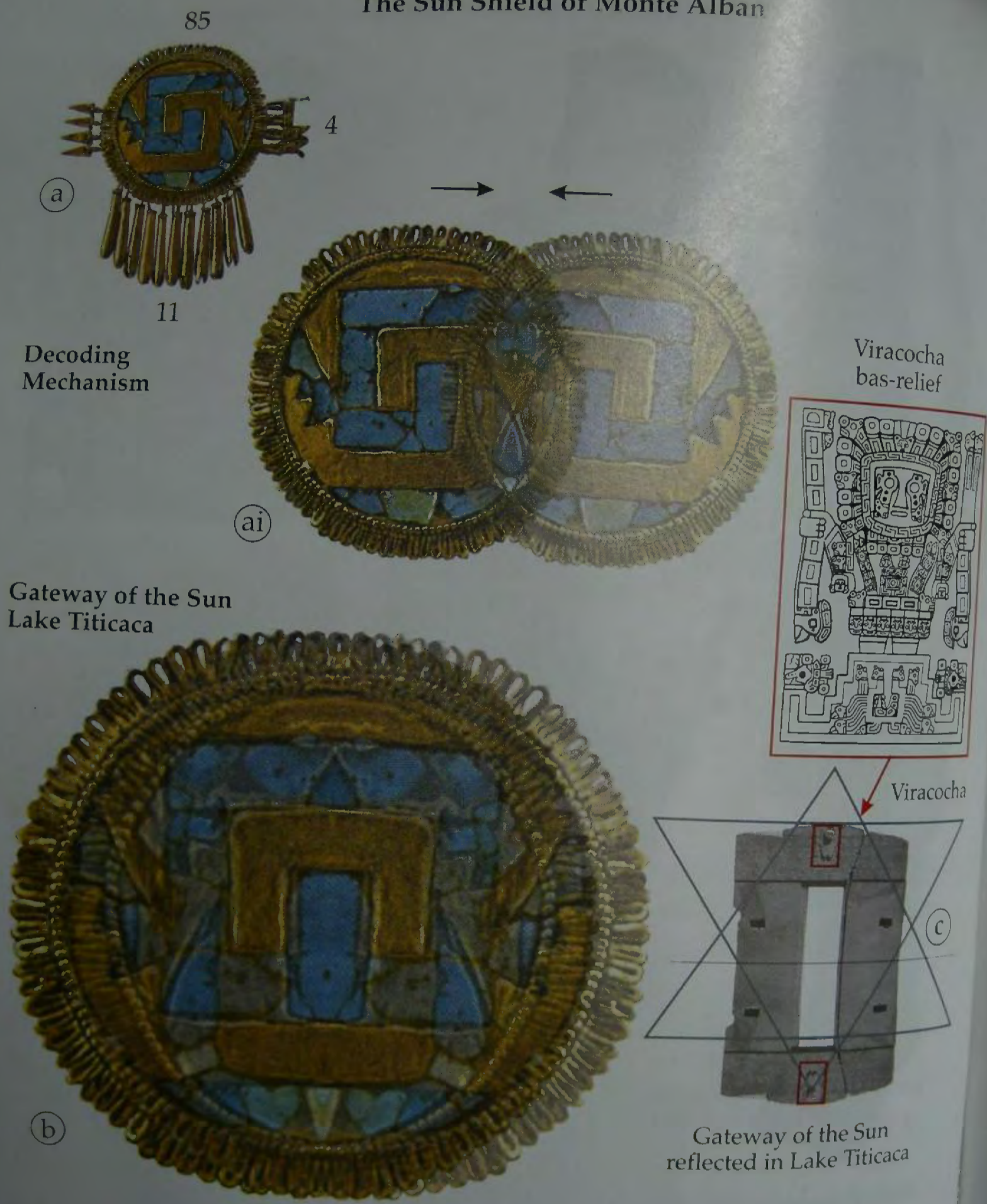

Plate 3. (a) Composite picture of the head and face of Viracocha. (b) Comparable picture of Viracocha, from the Viracocha vase of Tiahuanaco c. AD 500, Peru. (c) Composite picture of Lord Pacal, of Mexico (with the distinctive hairstyle), regurgitating a pearl [the symbol of the wisdom and the rebirth of Venus] inside a vesica pisces [the fish], the geometric symbol of Christianity. (d) Head of Lord Pacal, c. AD 750, from his tomb in the Pyramid of Viracocha, Palenque, shown inside a vesica pisces. These secret pictures reveal that Viracocha, Lord Pacal and Christ were all different incarnations of the same spiritual energy (God) on Earth at different moments in history. [Compare (c) to the head and shoulders of Lord Pacal, appearing as Xipe Totec in the Mural of Bonampak transformer (plate 4)].

The Sun Shield of Monte Alban



Decoding Mechanism

Gateway of the Sun
Lake Titicaca

Viracocha
bas-relief

Viracocha

Gateway of the Sun
reflected in Lake Titicaca

Plate 2. (a) The magnetic field of the Sun shifts every 1,366,040 days: $1,366,040 \div 365.25 = 3,740$ years, exactly. This gold and turquoise sun shield from Monte Alban, Mexico, encodes this period: 4 (arrows) \times 11 (pendants) \times 85 (gold loops) = 3,740 [20 sunspot cycles of 187 years]. The four arrows symbolise the four previous ages of the Sun which all ended in catastrophic destruction. The 85 loops around the perimeter represent magnetic field loops of sunspots on the Sun's surface. Closer inspection of the sun shield reveals another Mayan transformer (ai), and its reflection in the waters of Lake Titicaca—all inside a Star of David, the geometric symbol of Judaism. (c) The Gateway of the Sun from Tiahuanaco, Bolivia [mirror imaged to show the reflection in the water], contained within a Star of David. Other orientations of the transparencies reveal more pictures (see plates 3 and plates 6–13). Figure 9 reveals the geometric symbolism behind the Star of David.

Plate 3. (a) Con...
Viracocha, from...
Lord Pacal, of M...
the wisdom and...
of Christianity...
Inscriptions, Pa...
Viracocha, Lord...
(God) on Earth a...
Lord Pacal, appe...

The Sun Shield of Monte Alban

(a)

Viracocha



(b)

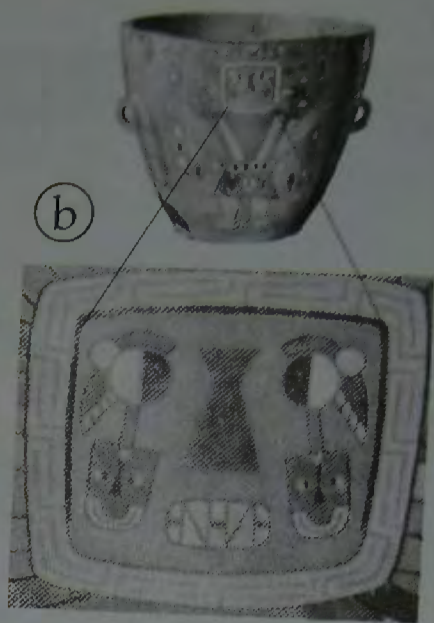

Viracocha bas-relief

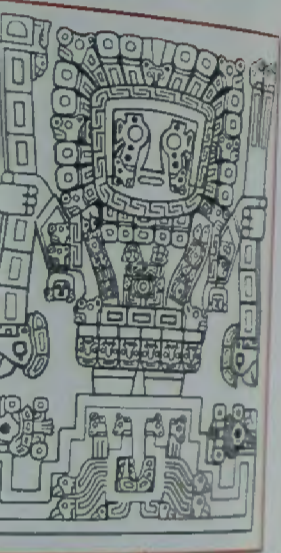

Lord Pacal



(d)



Viracocha



(c)

Start in this position then rotate + 99.9°



- 99.9°

of the Sun
Lake Titicaca

$040 \div 365.25 = 3,740$
Mexico, encodes this
of 187 years]. The
ded in catastrophic
ops of sunspots on
an transformer (ai)
e Sun at Tiahuanaco
e geometric symbol
or imaged to show
ations of the trans-
eals the geometric

Plate 3. (a) Composite picture of the head and face of Viracocha. (b) Comparable picture of Viracocha, from the Viracocha vase of Tiahuanaco c. AD 500, Peru. (c) Composite picture of Lord Pacal, of Mexico (with the distinctive hairstyle), regurgitating a pearl [the symbol of the wisdom and the rebirth of Venus] inside a vesica piscis [the fish], the geometric symbol of Christianity. (d) Head of Lord Pacal, c. AD 750, from his tomb in the Pyramid of Inscriptions, Palenque, shown inside a vesica piscis. These secret pictures reveal that Viracocha, Lord Pacal and Christ were all different incarnations of the same spiritual energy (God) on Earth at different moments in history. [Compare (c) to the head and shoulders of Lord Pacal, appearing as Xipe Totec in the Mural of Bonampak transformer (plate 4)].

The Sun Shield of Monte Alban

85



11

Decoding Mechanism



Viracocha bas relief



Gateway of the Sun
Lake Titicaca

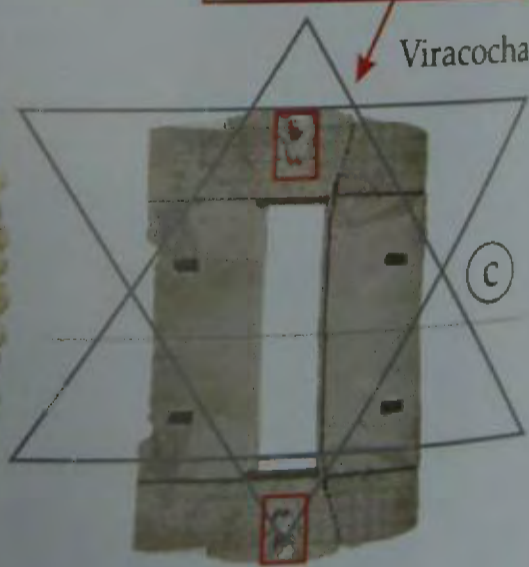

Gateway of the Sun
reflected in Lake Titicaca

Plate 2. (a) The magnetic field of the Sun shifts every 1,366,040 days: $(1,366,040 \div 365.25 = 3,740 \text{ years, exactly})$. This gold and turquoise sun shield from Monte Alban, Mexico, encodes this period: $4 \text{ (arrows)} \times 11 \text{ (pendants)} \times 85 \text{ (gold loops)} = 3,740$ [20 sunspot cycles of 187 years]. The four arrows symbolise the four previous ages of the Sun which all ended in catastrophic destruction. The 85 loops around the perimeter represent magnetic field loops of sunspots on the Sun's surface. Closer inspection of the sun shield reveals another Maya Transformer (ai) which when decoded reveals a composite picture (b) of the Gateway of the Sun at Tiahuanaco and its reflection in the waters of Lake Titicaca—all inside a Star of David, the geometric symbol of Judaism. (c) The Gateway of the Sun from Tiahuanaco, Bolivia [mirror imaged to show the reflection in the water] contained within a Star of David. (d) Other orientations of the transparencies reveal more pictures (see plates 3 and plates 6–13). Figure 9 reveals the geometric symbolism behind the Star of David.

Plate 3. (a) Viracocha Lord Paco wisdom Christian Palenque and Chri different appear

...these secret pictures reveal that
 ... Lord Pacal and Christ were all different incarnations of the same spiritual energy
 (God) on Earth at different moments in history. [Compare (c) to the head and shoulders of
 Lord Pacal, appearing as Xipe Totec in the Mural of Bonampak transformer (plate 4)].

The Sun Shield
 of Monte Alban

(a)

Viracocha

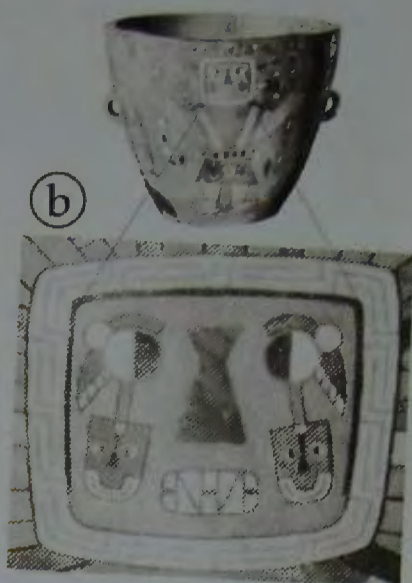
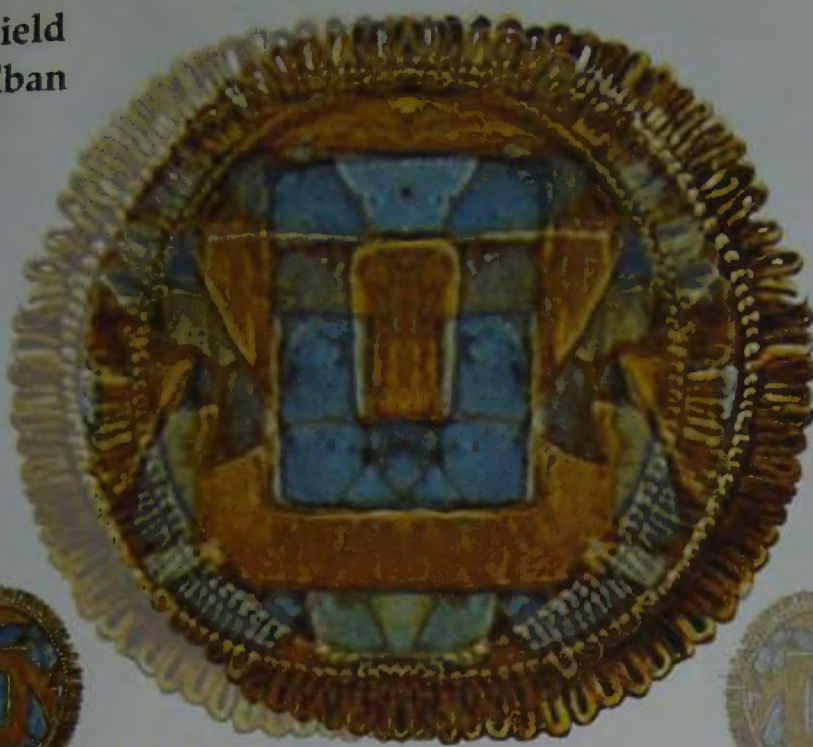

Lord Pacal



(d)



Start in this
 position then
 rotate + 99.9°

- 99.9°



Viracocha
 bas relief

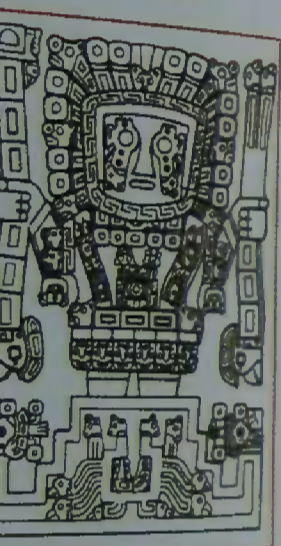

of the Sun
 Lake Titicaca

$366,040 \div 365.25 =$
 n, Mexico, encodes
 cycles of 187 years].
 ded in catastrophic
 ops of sunspots on
 va Transformer (ai)
 Sun at Tiahuanaco
 vid, the geometric
 [mirror imaged to
 her orientations of
 figure 9 reveals the

Plate 3. (a) Composite picture of the head and face of Viracocha. (b) Comparable picture of Viracocha, from the Viracocha vase of Tiahuanaco c. AD 500, Peru. (c) Composite Picture of Lord Pacal, of Mexico, (with the distinctive hairstyle) regurgitating a pearl [the symbol of the wisdom and the rebirth of Venus] inside a vesica pisces [the fish] the geometric symbol of Christianity (d) Head of Lord Pacal, c. AD 750, from his tomb in the Pyramid of Inscriptions, Palenque, shown inside a vesica pisces. These secret pictures reveal that Viracocha, Lord Pacal and Christ were all different incarnations of the same spiritual energy (God) on Earth at different moments in history. [Compare (c) to the head and shoulders of Lord Pacal, appearing as Xipe Totec in the Mural of Bonampak transformer (plate 4)].

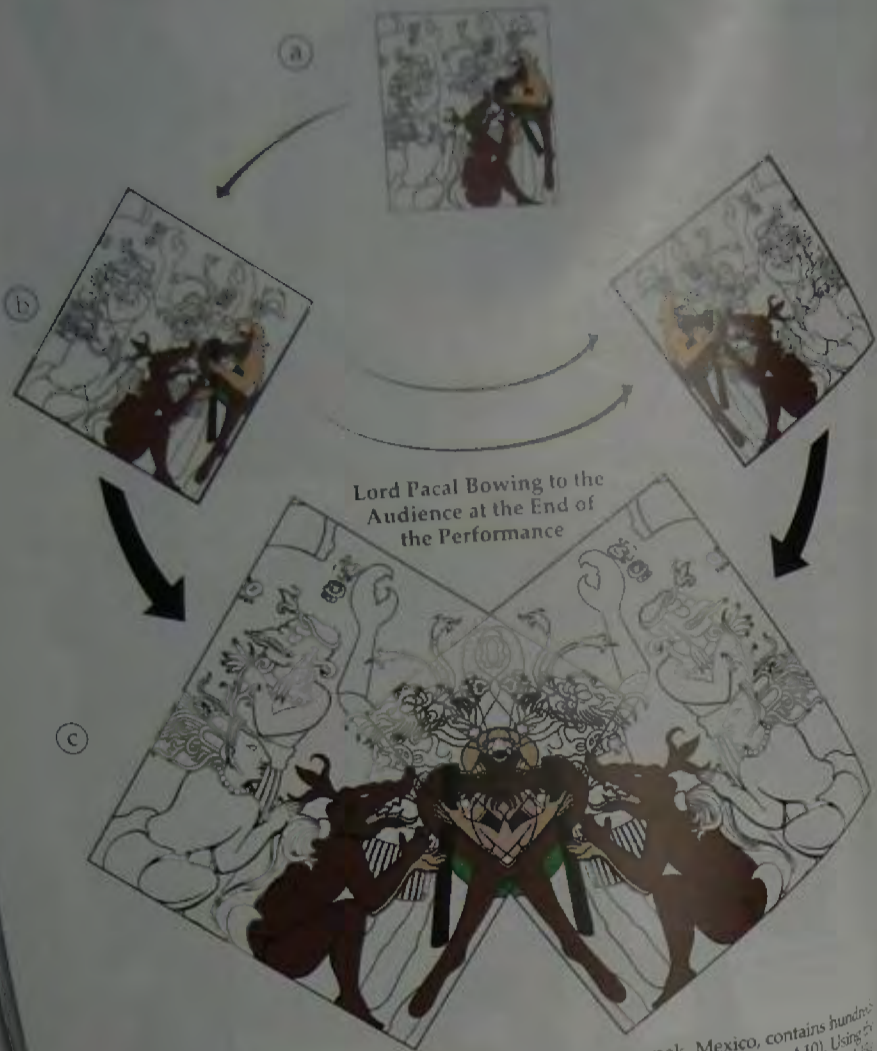

Plate 4. This picture, part of a mural from a temple at Bonampak, Mexico, contains hundreds of hidden pictures, just like the Amazing Lid of Palenque (plate 5b and figure A10). Using the same decoding process, the secret pictures are revealed. These tell stories that are enacted, like a theatre production, by the gods of the Maya. This decoded scene, obtained when the transparencies are juxtaposed by 66.6° [... here is wisdom, let him that hath understanding count the number of the beast; for it is the number of a man and his number is 666', Revelation XIII, 18] is the final one in the story of Xipe Totec, Lord of the Stags, God of the East, Fire and Sacrifice. It shows Xipe Totec, half-stag, half-man, carrying two sticks—which he used to rub together to make fire—bowing to the audience of two stags, who applaud the end of the performance. This finale, where the actors appear on stage and bow to the audience, is a common feature of these decodable pictures, which appear in many forms—carvings, paintings and jewellery—and are collectively known as Maya Transformers. The stag was associated with the Sun and worshipped by the Celts and other sun-worshipping civilizations.

"I saw an angel come down from Heaven ... and a rainbow was upon his head and his face was as it were, the Sun ... and he set his right foot upon the sea and his left foot upon the earth." Revelation X



Plate 5. (a) Stucco head of Lord Pacal. (b) Decoded picture from the carving on his tomb lid (the Amazing Lid of Palenque) that corresponds to the stucco head. A bat mask—the sign of death—covers his mouth. Covering the bat mask, a small man, wearing a hat, raises his arms and exposes his pure heart. (c) A small man wearing a hat with raised arms, from the tomb of Viracocha Pachacamac, Peru, c. AD 300. (d) Golden crab-man from the tomb of Viracocha, c. AD 500. The crab, which lives in the foam of the sea (on land and in the water), is a metaphor for the perfect human being—who is simultaneously in touch with the air, water, fire [sunshine] and earth. (e) Reconstruction of Viracocha Pachacamac (from the Museum of Archaeology, Lima, Peru). Inca accounts tell of two great leaders that walked the lands of Peru performing miracles, Viracocha (foam of the sea) and Viracocha Pachacamac '... a great leader, a white man of large stature and authoritative demeanour who took the highland route north from Tiahuanaco and followed the coast from Nazca to Sipan, performing miracles on the way. He spoke with great kindness, giving men instruction on how to live, admonishing them to love one another and show charity to all. They called him Viracocha Pachacamac which, in their language, means 'God of the World ...' (Cieza de Leon, Cronica del Peru, part II, chs. 4 and 5)

The Mural of Bonampak

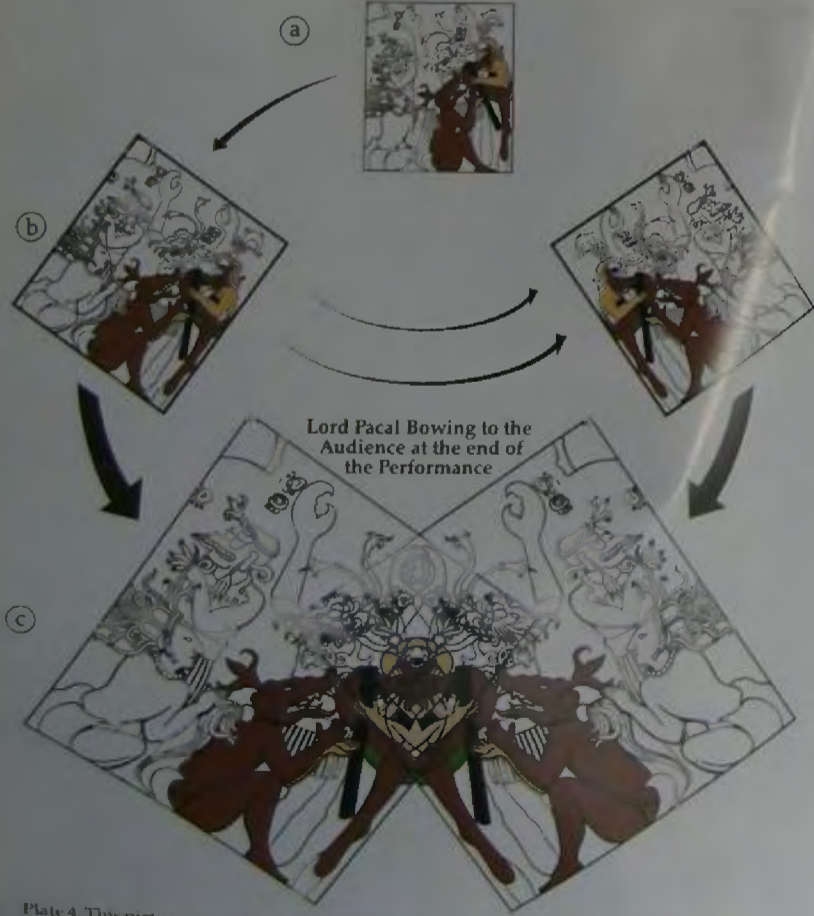

Plate 4. This picture, part of a mural from a temple at Bonampak, Mexico, contains hundreds of hidden pictures, just like the Amazing Lid of Palenque (plate 5b and figure A10). Using the same decoding process, the secret pictures are revealed. These tell stories that are enacted, like a theatre production, by the gods of the Maya. This decoded scene, obtained when the transparencies are juxtaposed by 66.6° [... here is wisdom, let him that hath understanding count the number of the beast; for it is the number of a man and his number is 666', Revelation XIII, 18] is the final one in the story of Xipe Totec, Lord of the Stags, God of the East, Fire and Sacrifice. It shows Xipe Totec, half-stag, half-man, carrying two sticks—which he used to rub together to make fire—bowing to the audience of two stags, who applaud the end of the performance. This finale, where the actors appear on stage and bow to the audience, is a common feature of these decodable pictures, which appear in many forms—carvings, paintings and jewellery—and are collectively known as Maya Transformers. The stag was associated with the Sun and worshipped by the Celts and other sun-worshipping civilizations.

The Sun-Kings of Mexico and Peru

"I saw an angel come down from Heaven ... and a rainbow was upon his head and his face was, as it were, the Sun ... and he set his right foot upon the sea and his left foot upon the earth." Revelation X



Plate 5. (a) Stucco head of Lord Pacal. (b) Decoded picture from the carving on his tomb lid (the Amazing Lid of Palenque) that corresponds to the stucco head. A bat mask—the sign of death—covers his mouth. Covering the bat mask, a small man, wearing a hat, raises his arms and exposes his pure heart. (c) A small man wearing a hat with raised arms, from the tomb of Viracocha Pachacamac, Peru, c. AD 300. (d) Golden crab-man from the tomb of Viracocha, c. AD 500. The crab, which lives in the foam of the sea (on land and in the water), is a metaphor for the perfect human being—who is simultaneously in touch with the air, water, fire [sunshine] and earth. (e) Reconstruction of Viracocha Pachacamac (from the Museum of Archaeology, Lima, Peru). Inca accounts tell of two great leaders that walked the lands of Peru performing miracles, Viracocha (foam of the sea) and Viracocha Pachacamac '... a great leader, a white man of large stature and authoritative demeanour who took the highland route north from Tiahuanaco and followed the coast from Nazca to Sipan, performing miracles on the way. He spoke with great kindness, giving men instruction on how to live, admonishing them to love one another and show charity to all. They called him Viracocha Pachacamac which, in their language, means 'God of the World ...' (Cieza de Leon, Cronica del Peru, Part II, Chs. 4 and 5).

The Mural of Bonampak

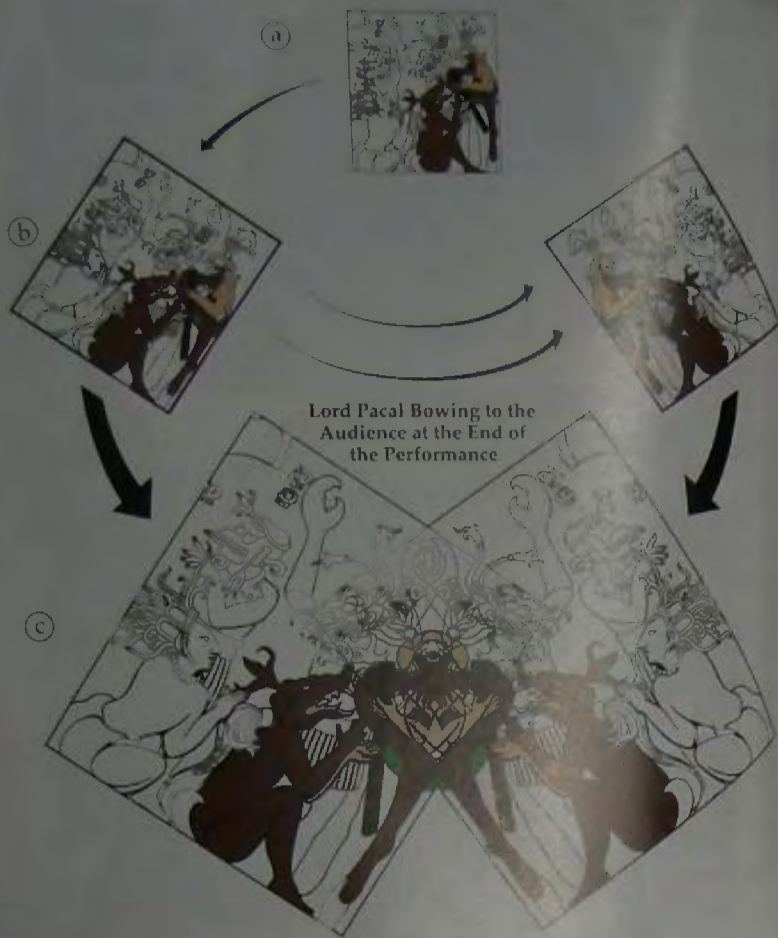

Plate 4. This picture, part of a mural from a temple at Bonampak, Mexico, contains hundreds of hidden pictures, just like the Amazing Lid of Palenque (plate 5b and figure A10). Using the same decoding process, the secret pictures are revealed. These tell stories that are enacted, like a theatre production, by the gods of the Maya. This decoded scene, obtained when the transparencies are juxtaposed by 66.6° [... here is wisdom, let him that hath understanding count the number of the beast; for it is the number of a man and his number is 666, Revelation XIII, 18] is the final one in the story of Xipe Totec, Lord of the Stags, God of the East, Fire and Sacrifice. It shows Xipe Totec, half-stag, half-man, carrying two sticks—which he used to rub together to make fire—bowing to the audience of two stags, who applaud the end of the performance. This finale, where the actors appear on stage and bow to the audience, is a common feature of these decodable pictures, which appear in many forms—carvings, paintings and jewellery—and are collectively known as Maya Transformers. The stag was associated with the Sun and worshipped by the Celts and other sun-worshipping civilizations.

The Sun-Kings of Mexico and Peru



Plate 5. (a) Stucco head of Lord Pacal. (b) Decoded picture from the carving on his tomb lid (the Amazing Lid of Palenque) that corresponds to the stucco head. A bat mask—the sign of death—covers his mouth. Covering the bat mask, a small man, wearing a hat, raises his arms and exposes his pure heart. (c) A small man wearing a hat with raised arms, from the tomb of Viracocha Pachacamac, Peru, c. AD 300. (d) Golden crab-man from the tomb of Viracocha, c. AD 500. The crab, which lives in the foam of the sea (on land and in the water), is a metaphor for the perfect human being—who is simultaneously in touch with the air, water, fire [sunshine] and earth. (e) Reconstruction of Viracocha Pachacamac (from the Museum of Archaeology, Lima, Peru). Inca accounts tell of two great leaders that walked the lands of Peru performing miracles, Viracocha (foam of the sea) and Viracocha Pachacamac '... a great leader, a white man of large stature and authoritative demeanour who took the highland route north from Tiahuanaco and followed the coast from Nazca to Sipan, performing miracles on the way. He spoke with great kindness, giving men instruction on how to live, admonishing them to love one another and show charity to all. They called him Viracocha Pachacamac which, in their language, means 'God of the World ...' (Cieza de Leon, Cronica del Peru, part II, chs. 4 and 5).

The Mural of Bonampak

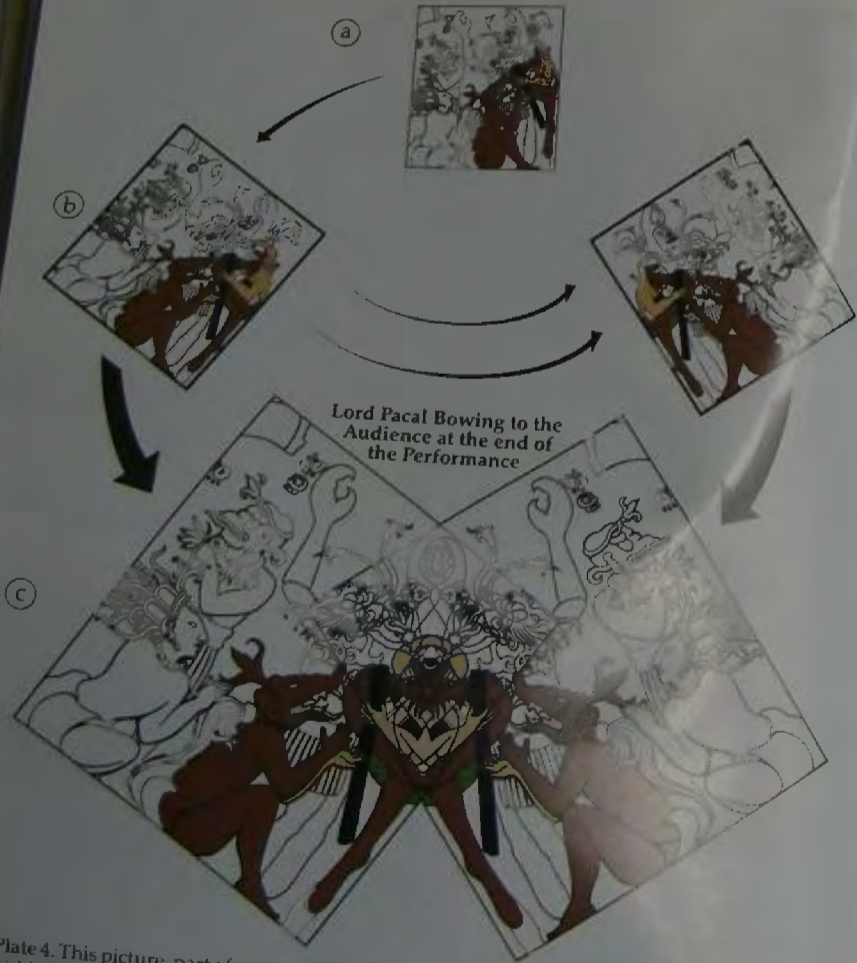

Plate 4. This picture, part of a mural from a temple at Bonampak, Mexico, contains hundreds of hidden pictures, just like the Amazing Lid of Palenque (plate 5b and figure A10). Using the same decoding process, the secret pictures are revealed. These tell stories that are enacted, like a theatre production, by the gods of the Maya. This decoded scene, obtained when the transparencies are juxtaposed by 66.6° [... here is wisdom, let him that hath understanding count the number of the beast; for it is the number of a man and his number is 666, Revelation XIII, 18] is the final one in the story of Xipe Totec, Lord of the Stags, God of the East, Fire and Sacrifice. It shows Xipe Totec, half-stag, half-man, carrying two sticks—which he used to rub together to make fire—bowing to the audience of two stags, who applaud the end of the performance. This finale, where the actors appear on stage and bow to the audience, is a common feature of these decodable pictures, which appear in many forms—carvings, paintings and jewellery—and are collectively known as Maya Transformers. The stag was associated with the Sun and worshipped by the Celts and other sun-worshipping civilizations.

The Sun-Kings of Mexico and Peru



Plate 5. (a) Stucco head of Lord Pacal. (b) Decoded picture from the carving on his tomb lid (the Amazing Lid of Palenque) that corresponds to the stucco head. A bat mask—the sign of death—covers his mouth. Covering the bat mask, a small man, wearing a hat, raises his arms and exposes his pure heart. (c) A small man wearing a hat with raised arms, from the tomb of Viracocha Pachacamac, Peru, c. AD 300. (d) Golden crab-man from the tomb of Viracocha, c. AD 500. The crab, which lives in the foam of the sea (on land and in the water) is a metaphor for the perfect human being—who is simultaneously in touch with the air, water, fire [sunshine] and earth. (e) Reconstruction of Viracocha Pachacamac (from the Museum of Archaeology, Lima, Peru). Inca accounts tell of two great leaders that walked the lands of Peru performing miracles, Viracocha (foam of the sea) and Viracocha Pachacamac '... a great leader, a white man of large stature and authoritative demeanour who took the highland route north from Tiahuanaco and followed the coast from Nazca to Sipan, performing miracles on the way. He spoke with great kindness, giving men instruction on how to live, admonishing them to love one another and show charity to all. They called him Viracocha Pachacamac which, in their language, means 'God of the World ...' (Cieza de Leon, Cronica del Peru, part II, chs. 4 and 5).

The Sun-Kings of Mexico and Peru

'I saw an angel come down from Heaven . . . and a rainbow was upon his head and his face was, as it were, the Sun . . . and he set his right foot upon the sea and his left foot upon the earth'. Revelation X



Plate 5. (a) Stucco head of Lord Pacal. (b) Decoded picture from the carving on his tomb lid (the Amazing Lid of Palenque) that corresponds to the stucco head. A bat mask—the sign of death—covers his mouth. Covering the bat mask, a small man, wearing a hat, raises his arms and exposes his pure heart. (c) A small man wearing a hat with raised arms, from the tomb of Viracocha Pachacamac, Peru, c. AD 300. (d) Golden crab-man from the tomb of Viracocha, c. AD 500. The crab, which lives in the foam of the sea (on land and in the water), is a metaphor for the *perfect human being*—who is simultaneously in touch with the air, water, fire [sunshine] and earth. (e) Reconstruction of Viracocha Pachacamac (from the Museum of Archaeology, Lima, Peru). Inca accounts tell of two great leaders that walked the lands of Peru performing miracles, Viracocha (*foam of the sea*) and Viracocha Pachacamac ' . . . a great leader, a white man of large stature and authoritative demeanour who took the highland route north from Tiahuanaco and followed the coast from Nazca to Sipan, performing miracles on the way. He spoke with great kindness, giving men instruction on how to live, admonishing them to love one another and show charity to all. They called him Viracocha Pachacamac which, in their language, means 'God of the World . . .' (Cieza de Leon, *Cronica del Peru*, part II, chs. 4 and 5)

contains hundreds
are A10). Using the
at are enacted, like
obtained when the
ath understanding
is 666', Revelation
of the East, Fire and
which he used to rub
to the audience, is
—carvings, paintings
stag was associated
vilizations.

The Sun-Kings of Mexico and Peru

"I saw an angel come down from Heaven
... and a rainbow was upon his head and his face was,
as it were, the Sun... and he set his right foot upon the
sea and his left foot upon the earth. Revelation X.



Plate 5. (a) Stucco head of Lord Pacal. (b) Decoded picture from the carving on his tomb lid (the Amazing Lid of Palenque) that corresponds to the stucco head. A bat mask—the sign of death—covers his mouth. Covering the bat mask, a small man, wearing a hat, raises his arms and exposes his pure heart. (c) A small man wearing a hat with raised arms, from the tomb of Viracocha Pachacamac, Peru c. AD 300. (d) Golden crab-man from the tomb of Viracocha, c. AD 500. The crab, which lives in the foam of the sea (on land and in the water) is a metaphor for the perfect human being—who is simultaneously in touch with the air, water, fire [sunshine] and earth. (e) Reconstruction of Viracocha Pachacamac (from the Museum of Archaeology, Lima, Peru). Inca accounts tell of two great leaders that walked the lands of Peru performing miracles, Viracocha (*foam of the sea*) and Viracocha Pachacamac '...a great leader, a white man of large stature and authoritative demeanour who took the highland route north from Tiahuanaco and followed the coast from Nazca to Sipan, performing miracles on the way. He spoke with great kindness, giving men instruction on how to live, admonishing them to love one another and show charity to all. They called him Viracocha Pachacamac which, in their language, means 'God of the World...' (Cieza de Leon, *Cronica del Peru*, Part II, Chs. 4 and 5).

The Mural of Bonampak



Lord Pacal Bowing to the Audience at the end of the Performance

Plate 4. This picture, part of a mural from a temple at Bonampak, Mexico, contains hundreds of hidden pictures, just like the Amazing Lid of Palenque (plate 5b and figure A10). Using the same decoding process, the secret pictures are revealed. These tell stories that are enacted, like a theatre production, by the gods of the Maya. This decoded scene, obtained when the transparencies are juxtaposed by 66.6° ['...here is wisdom, let him that hath understanding count the number of the beast; for it is the number of a man and his number is 666', Revelation XIII,18] is the final one in the story of Xipe Totec, Lord of the Stags, God of the East, Fire and Sacrifice. It shows Xipe Totec, half-stag, half-man, carrying two sticks—which he used to rub together to make fire—bowing to the audience of two stags, who applaud the end of the performance. This finale, where the actors appear on stage and bow to the audience, is a common feature of these decodable pictures, which appear in many forms—carvings, paintings and jewellery—and are collectively known as Maya Transformers. The stag was associated with the Sun and worshipped by the Celts and other sun worshipping civilizations.

Plate 5. (a) Stupa of the Amazing Lid of Palenque, which covers the death—covers the death—and exposes his death. (b) Viracocha Pachacuti, 500. The crab, with perfect human beauty. (c) Reconstructions of the earth. (d) Inca accounts of miracles, Viracocha's large stature and Tiahuanaco and spoke with great one another and language, means

The Mural of Bonampak

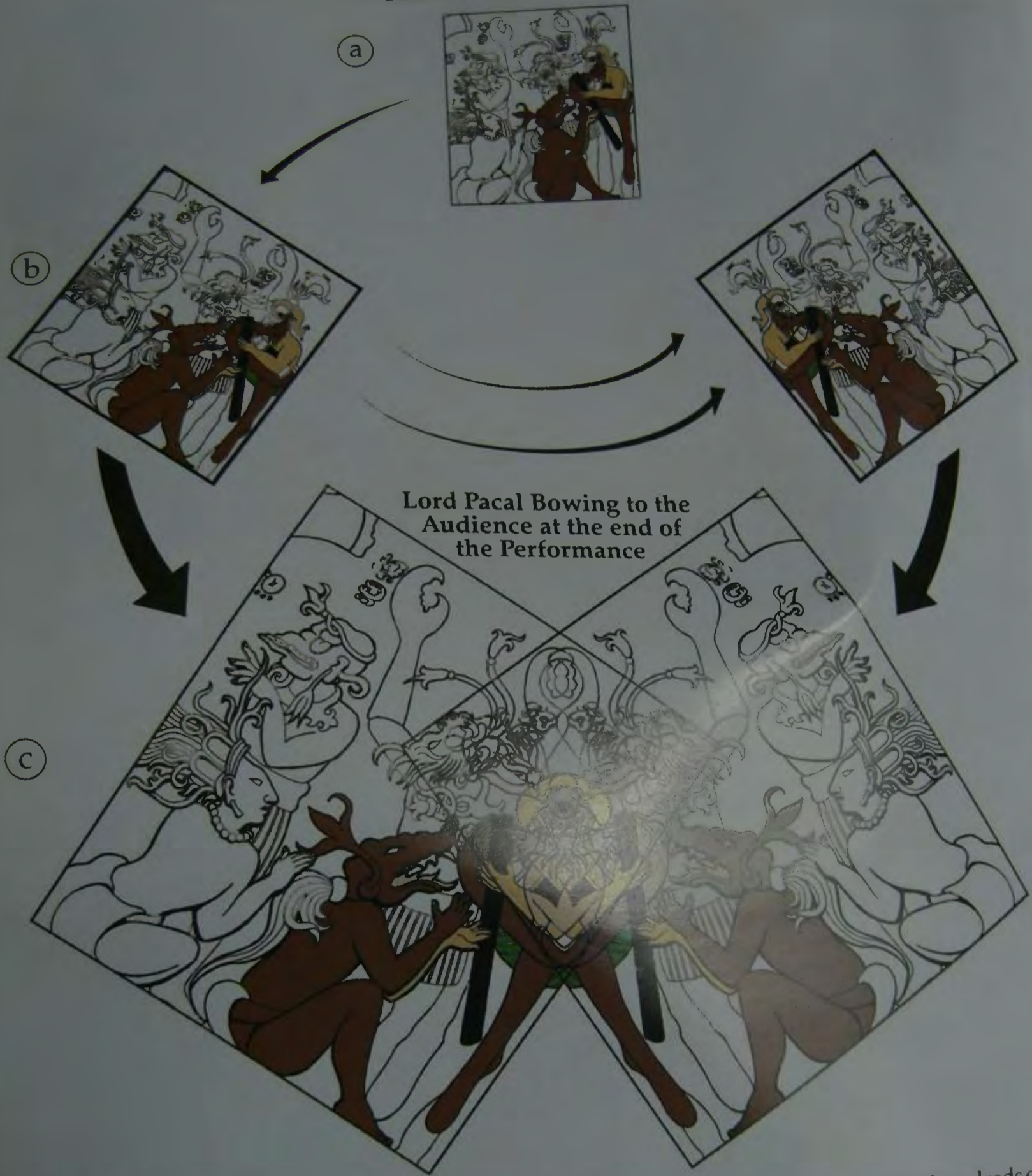

Plate 4. This picture, part of a mural from a temple at Bonampak, Mexico, contains hundreds of hidden pictures, just like the Amazing Lid of Palenque (plate 5b and figure A10). Using the same decoding process, the secret pictures are revealed. These tell stories that are enacted, like a theatre production, by the gods of the Maya. This decoded scene, obtained when the transparencies are juxtaposed by 66.6° ['...here is wisdom, let him that hath understanding count the number of the beast; for it is the number of a man and his number is 666', Revelation XIII, 18] is the final one in the story of Xipe Totec, Lord of the Stags, God of the East, Fire and Sacrifice. It shows Xipe Totec, half-stag, half-man, carrying two sticks—which he used to rub together to make fire—bowing to the audience of two stags, who applaud the end of the performance. This finale, where the actors appear on stage and bow to the audience, is a common feature of these decodable pictures, which appear in many forms—carvings, paintings and jewellery—and are collectively known as Maya Transformers. The stag was associated with the Sun and worshipped by the Celts and other sun worshipping civilizations.

Lord Pacal as the Stag



Plate 6. Lord Pacal as the stag, a personification of Christ. The small man with the hat from Peru appears between his antlers—which become his wings. A baby bird, representing Quetzalcoatl, covers his mouth. Another bird hangs on a chain from around his neck. The small man with the hat also appears with wings in a scene from the mosaic mask of Palenque (plate 24).

The Birth of Christ

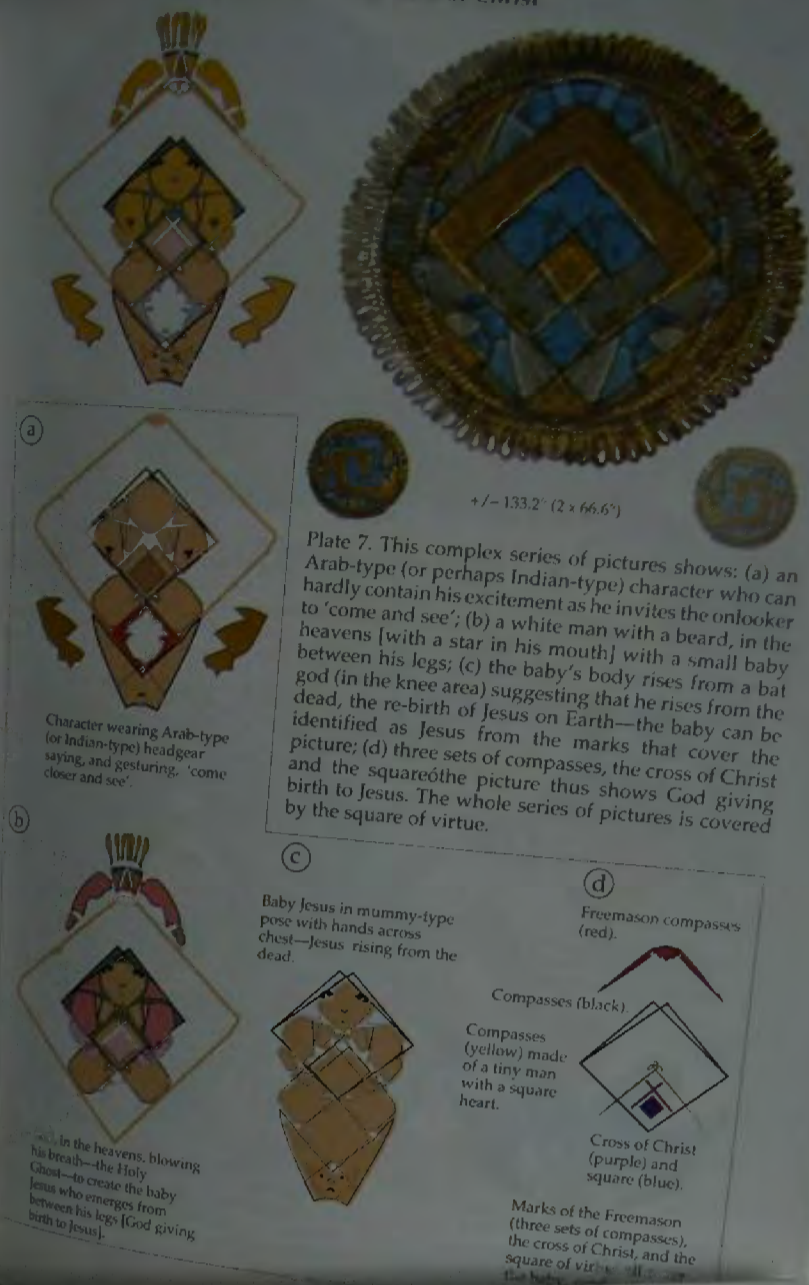

Plate 7. This complex series of pictures shows: (a) an Arab-type (or perhaps Indian-type) character who can hardly contain his excitement as he invites the onlooker to 'come and see'; (b) a white man with a beard, in the heavens [with a star in his mouth] with a small baby between his legs; (c) the baby's body rises from a bat god (in the knee area) suggesting that he rises from the dead, the re-birth of Jesus on Earth—the baby can be identified as Jesus from the marks that cover the picture; (d) three sets of compasses, the cross of Christ and the square—the picture thus shows God giving birth to Jesus. The whole series of pictures is covered by the square of virtue.

Character wearing Arab-type (or Indian-type) head-gear saying, and gesturing, 'come closer and see'.

God, in the heavens, blowing his breath—the Holy Ghost—to create the baby Jesus who emerges from between his legs [God giving birth to Jesus].

Baby Jesus in mummy-type pose with hands across chest—Jesus rising from the dead.

Freemason compasses (red).

Compasses (black).

Compasses (yellow) made of a tiny man with a square heart.

Cross of Christ (purple) and square (blue).

Marks of the Freemason (three sets of compasses), the cross of Christ, and the square of virtue, all cover the baby, confirming identification.

Lord Pacal as the Stag



Plate 6. Lord Pacal as the stag, a personification of Christ. The small man with the hat from Peru appears between his antlers—which become his wings. A baby bird, representing Quetzalcoatl, covers his mouth. Another bird hangs on a chain from around his neck. The small man with the hat also appears with wings in a scene from the Mosaic Mask of Palenque (plate 24).

The Birth of Christ

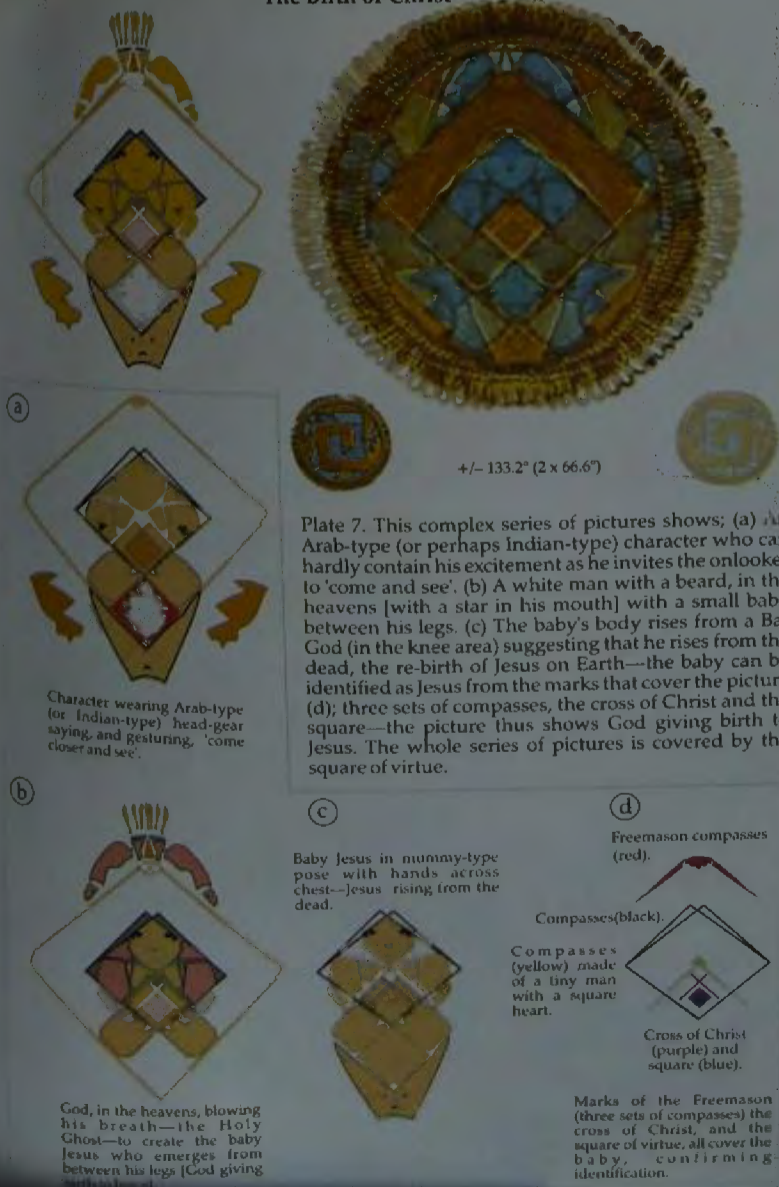

Plate 7. This complex series of pictures shows: (a) An Arab-type (or perhaps Indian-type) character who can hardly contain his excitement as he invites the onlooker to 'come and see'. (b) A white man with a beard, in the heavens [with a star in his mouth] with a small baby between his legs. (c) The baby's body rises from a Bat God (in the knee area) suggesting that he rises from the dead, the re-birth of Jesus on Earth—the baby can be identified as Jesus from the marks that cover the picture (d); three sets of compasses, the cross of Christ and the square—the picture thus shows God giving birth to Jesus. The whole series of pictures is covered by the square of virtue.

Character wearing Arab-type (or Indian-type) head-gear saying, and gesturing, 'come closer and see'.

God, in the heavens, blowing his breath—the Holy Ghost—to create the baby Jesus who emerges from between his legs [God giving birth to Jesus].

Baby Jesus in mummy-type pose with hands across chest—Jesus rising from the dead.

Freemason compasses (red).

Compasses (black).

Compasses (yellow) made of a tiny man with a square heart.

Cross of Christ (purple) and square (blue).

Marks of the Freemason (three sets of compasses), the cross of Christ, and the square of virtue, all cover the baby, confirming identification.

Lord Pacal as the Stag

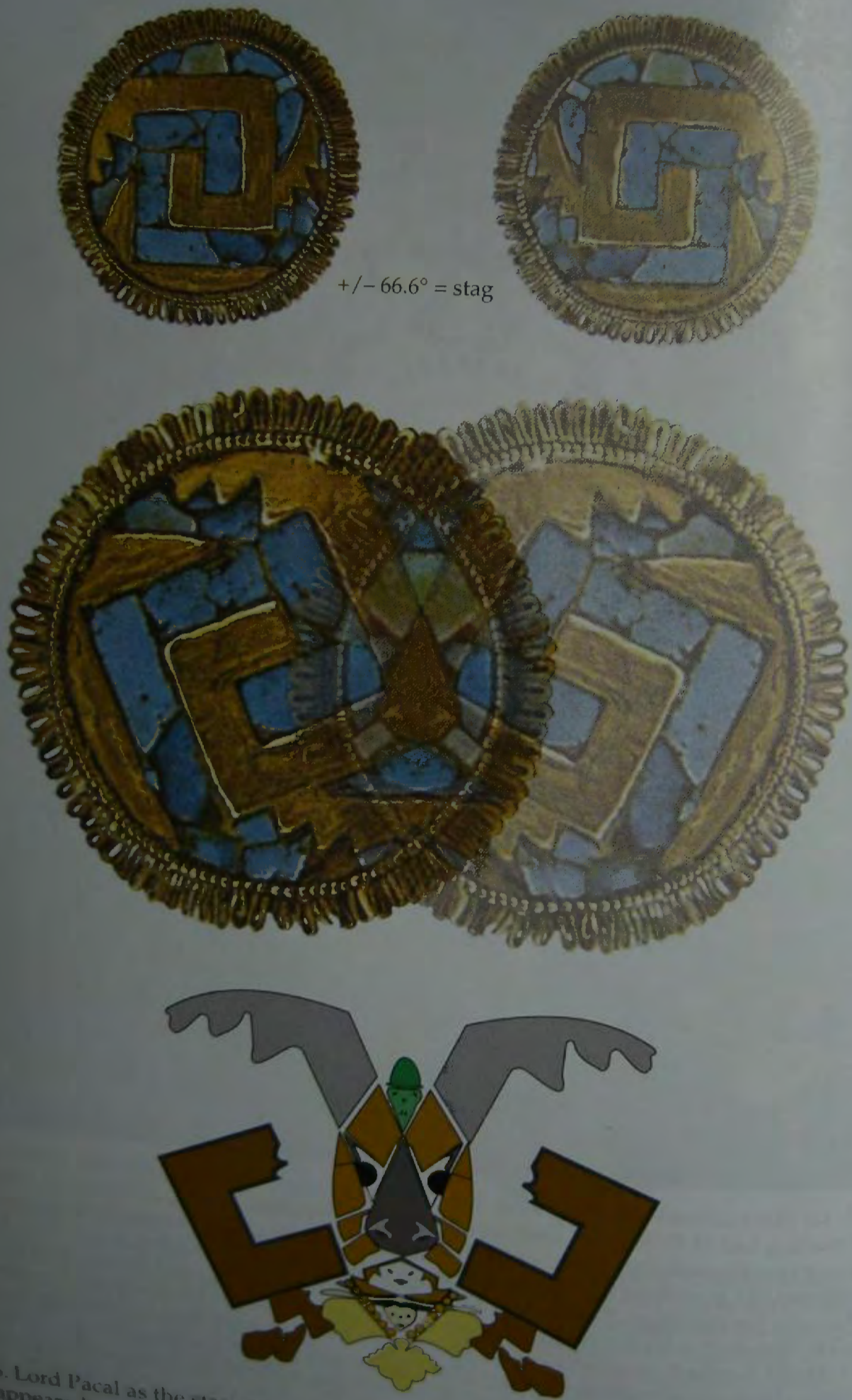
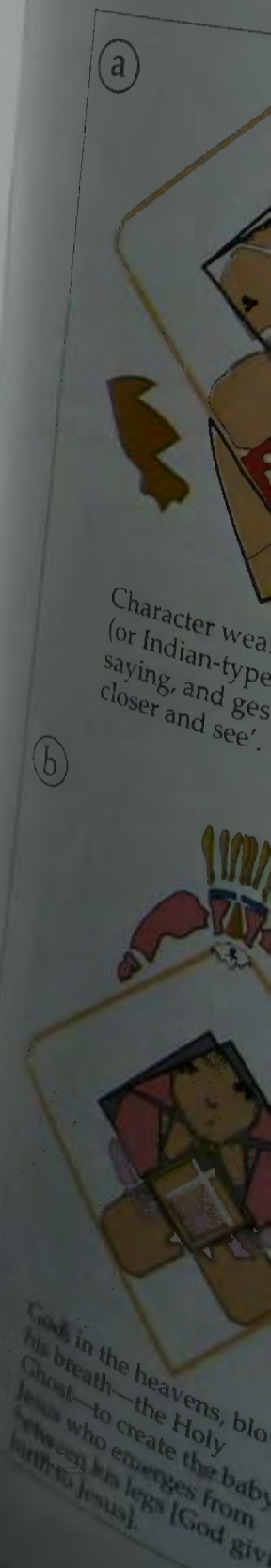

Plate 6. Lord Pacal as the stag, a personification of Christ. The small man with the hat from Peru appears between his antlers—which become his wings. A baby bird, representing Quetzalcoatl, covers his mouth. Another bird hangs on a chain from around his neck. The small man with the hat also appears with wings in a scene from the mosaic mask of Palenque (plate 24).





+/- 133.2° (2 x 66.6°)

Plate 7. This complex series of pictures shows: (a) an Arab-type (or perhaps Indian-type) character who can hardly contain his excitement as he invites the onlooker to 'come and see'; (b) a white man with a beard, in the heavens [with a star in his mouth] with a small baby between his legs; (c) the baby's body rises from a bat god (in the knee area) suggesting that he rises from the dead, the re-birth of Jesus on Earth—the baby can be identified as Jesus from the marks that cover the picture; (d) three sets of compasses, the cross of Christ and the square—the picture thus shows God giving birth to Jesus. The whole series of pictures is covered by the square of virtue.



Character wearing Arab-type (or Indian-type) headgear saying, and gesturing, 'come closer and see'.



God, in the heavens blowing his breath—the Holy Spirit—to create the baby Jesus who emerges from between his legs [God giving birth to Jesus].

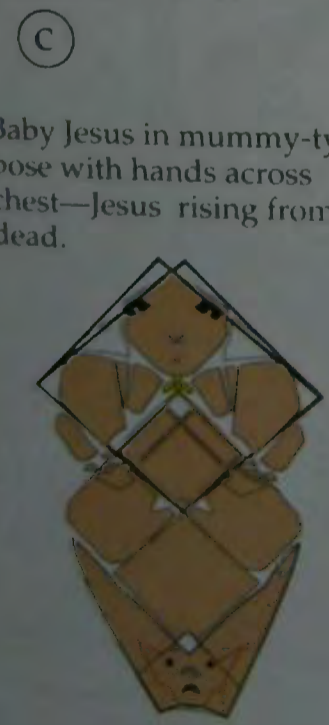

Baby Jesus in mummy-type pose with hands across chest—Jesus rising from the dead.

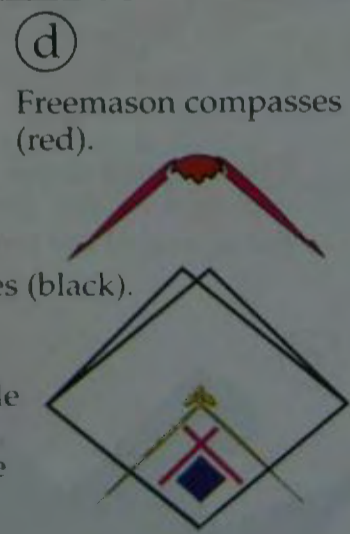

Freemason compasses (red).

Compasses (black).

Compasses (yellow) made of a tiny man with a square heart.

Cross of Christ (purple) and square (blue).

Marks of the Freemason (three sets of compasses), the cross of Christ, and the square of virtue, all cover the baby, confirming...

around his neck. The
saic mask of Palenque

... following
... the Holy
Ghost—to create the baby
Jesus who emerges from
between his legs [God giving
birth to Jesus].

square (blue).
Marks of the Freemason
(three sets of compasses),
the cross of Christ, and the
square of virtue.

The Birth of Christ



+/- 133.2° (2 x 66.6°)



Character wearing Arab-type (or Indian-type) head-gear saying, and gesturing, 'come closer and see'.

Plate 7. This complex series of pictures shows; (a) An Arab-type (or perhaps Indian-type) character who can hardly contain his excitement as he invites the onlooker to 'come and see'. (b) A white man with a beard, in the heavens [with a star in his mouth] with a small baby between his legs. (c) The baby's body rises from a Bat God (in the knee area) suggesting that he rises from the dead, the re-birth of Jesus on Earth—the baby can be identified as Jesus from the marks that cover the picture (d); three sets of compasses, the cross of Christ and the square—the picture thus shows God giving birth to Jesus. The whole series of pictures is covered by the square of virtue.



(c)

Baby Jesus in mummy-type pose with hands across chest—Jesus rising from the dead.

(d)

Freemason compasses (red).



Compasses (black).



Compasses (yellow) made of a tiny man with a square heart.

Cross of Christ (purple) and square (blue).

Marks of the Freemason (three sets of compasses) the cross of Christ, and the square of virtue, all cover the baby, confirming identification.

God, in the heavens, blowing his breath—the Holy Ghost—to create the baby Jesus who emerges from between his legs [God giving birth to Jesus].

the hat from representing his neck. The k of Palenque

Lord Pacal as the Stag



+/- 66.6° = stag

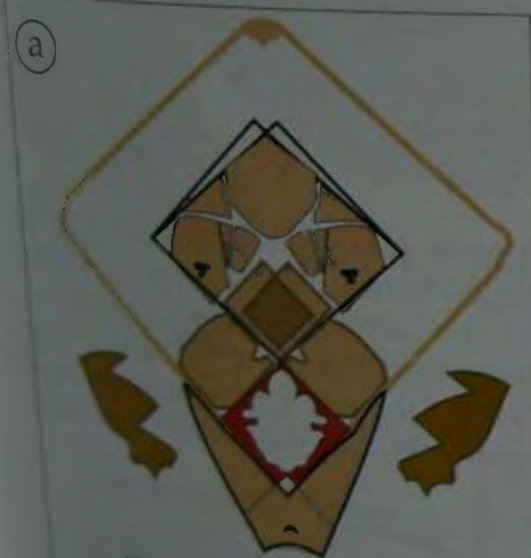

Plate 6. Lord Pacal as the stag, a personification of Christ. The small man with the hat from Peru appears between his antlers—which become his wings. A baby bird, representing Quetzalcoatl, covers his mouth. Another bird hangs on a chain from around his neck. The small man with the hat also appears with wings in a scene from the Mosaic Mask of Palenque (plate 24).

The Birth of Christ



$\pm 133.2^\circ$ ($2 \times 66.6^\circ$)



Character wearing Arab-type (or Indian-type) headgear saying, and gesturing, 'come closer and see'.



God, in the heavens, blowing his breath—the Holy Spirit—to create the baby Jesus who emerges from between his legs [God giving birth to Jesus].

(c) Baby Jesus in mummy-type pose with hands across chest—Jesus rising from the dead.



(d) Freemason compasses (red).

Compasses (black).

Compasses (yellow) made of a tiny man with a square heart.



Cross of Christ (purple) and square (blue).

Marks of the Freemason (three sets of compasses), the cross of Christ, and the square of virtue, all cover the baby, confirming identification.

an with the hat from y bird, representing around his neck. The atic mask of Palenque



+/- 133.2° (2 x 66.6°)

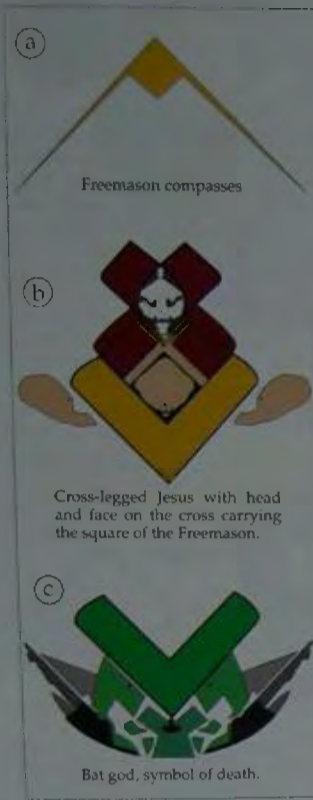

Freemason compasses

Cross-legged Jesus with head and face on the cross carrying the square of the Freemason.

Bat god, symbol of death.

Plate 8. Composite picture showing: (a) Jesus sitting cross-legged beneath the compasses of the Freemason; (b) he carries the square of the Freemason, representing virtue and purity and is (c) carried away by the bat god—meaning that Jesus was a Freemason who died a virtuous man

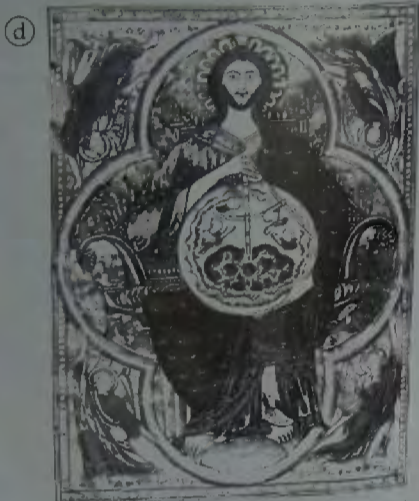

Christ as the Great Architect of the Universe, using the compasses of the Freemason. (Bible Moralisee c. 1235-1245, Laborde facsimile, 1911-27, British Library)

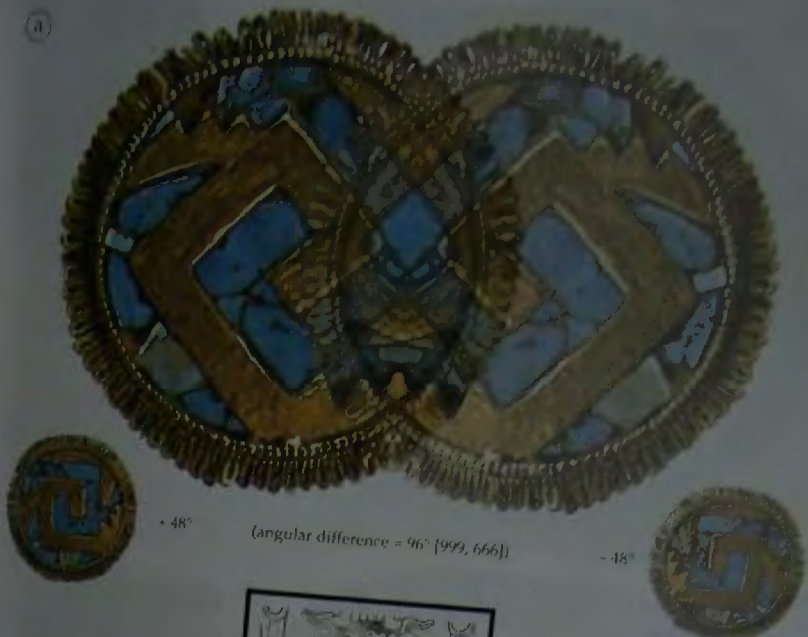

+ 48°

(angular difference = 96° [999, 666])

- 48°



Sun God from Aztec calendar stone.



Sun God from the Amazing Lid of Palenque.

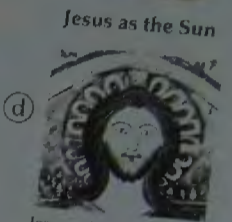

Jesus as the Sun

Jesus, with a halo of sunspot loops. (Bible Moralisee c. 1235-1245, Laborde facsimile, 1911-27, British Library)



Plate 9. (a) Composite picture showing Jesus as the Sun God, with an extended tongue, and sunspot loops on his head, inside a vesica piscis (the geometric symbol of Christianity). He is seen with the cross of the crucifixion across his forehead, the favoured location for the cross of baptism.



+/- 133.2° (2 x 66.6°)



Freemason compasses.

Cross-legged Jesus with head and face on the cross carrying the square of the Freemason.

Bat God, symbol of death.

Plate 8. Composite picture showing: (a) Jesus sitting cross-legged beneath the compasses of the Freemason; (b) He carries the square of the Freemason, representing virtue and purity and is (c) carried away by the Bat God—meaning that Jesus was a Freemason who died a virtuous man.

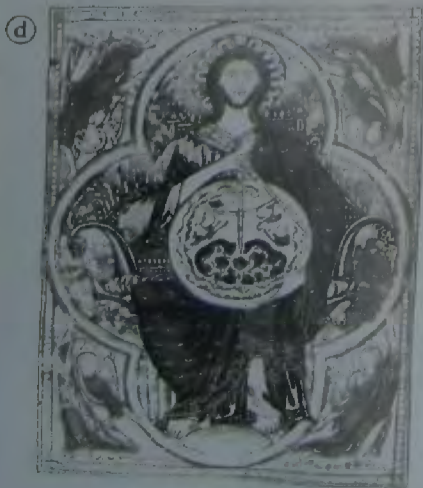

Christ as the Great Architect of the Universe, using the compasses of the Freemason. (Bible Moralisee c. 1235-1245, Laborde facsimile, 1911-27, British Library)



+ 48°

(angular difference = 96° [999, 666])

- 48°



Sun God from Aztec Calendar stone



Sun God from the Amazing Lid of Palenque.

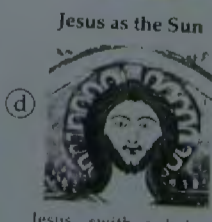

Jesus as the Sun

Jesus, with a halo of sunspot loops. (Bible Moralisee c. 1235-1245, Laborde facsimile, 1911-27, British Library)



Plate 9. (a) Composite picture showing Jesus as the Sun God, with an extended tongue, and sunspot loops on his head, inside a vesica piscis (the geometric symbol of Christianity). He is seen with the cross of the Crucifixion across his forehead, the favoured location for the cross of baptism.

The Life of Christ



+/- 133.2° (2 x 66.6°)

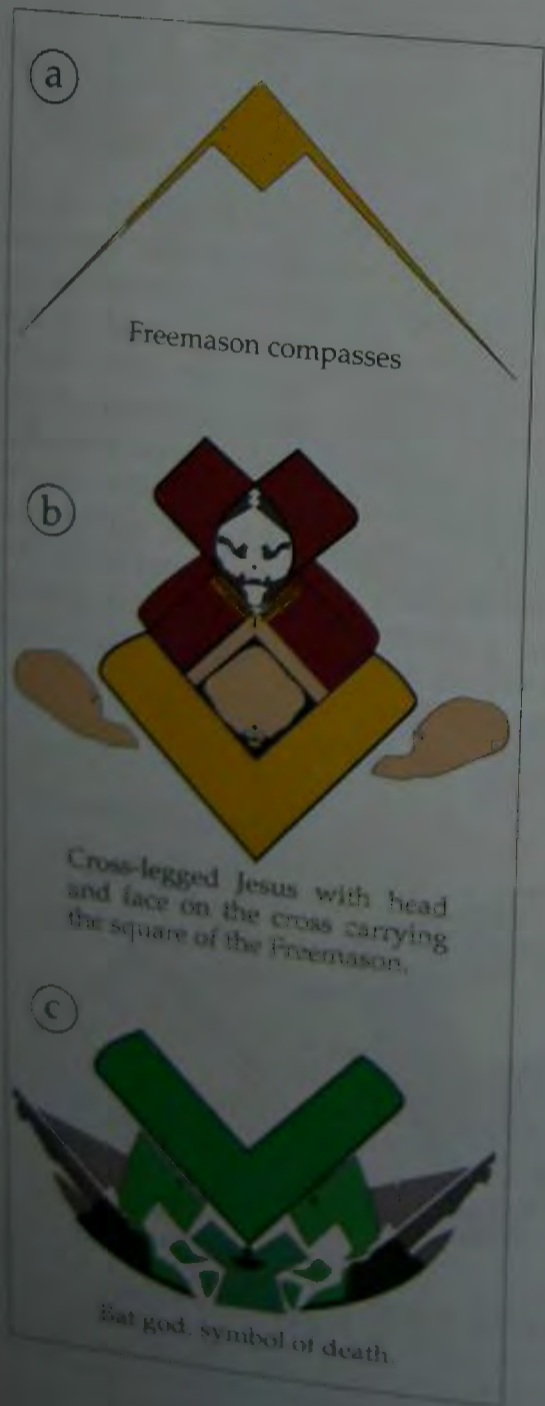

Plate 8. Composite picture showing: (a) Jesus sitting cross-legged beneath the compasses of the Freemason; (b) he carries the square of the Freemason, representing virtue and purity and is (c) carried away by the bat god—meaning that Jesus was a Freemason who died a virtuous man.



Christ as the Great Architect of the Universe, using the compasses of the Freemason. (*Bible Moralisee* c. 1235-1245 Laborde facsimile, 1911-27, British Library)

Sun God from calendar

Plate 9. (a) Composite sunspot loops on the cross of baptism.

Death by Crucifixion

(a)



+ 48°

(angular difference = 96° [999, 666])



- 48°

(a) Jesus
esses of the
re of the
rity and is
aning that
uous man.

Jesus as the Sun

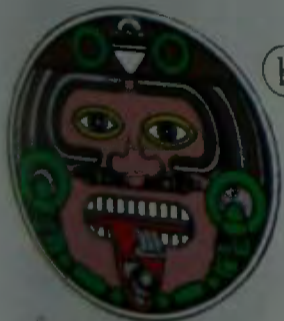

Sun God from Aztec
calendar stone.

(b)



Sun God from the Amazing Lid
of Palenque.

(c)



Jesus, with a halo of
sunspot loops. (*Bible
Moralisée* c. 1235-1245,
Laborde facsimile,
1911-27, British Library)

(d)



Plate 9. (a) Composite picture showing Jesus as the Sun God, with an extended tongue, and sunspot loops on his head, inside a vesica pisces (the geometric symbol of Christianity). He is seen with the cross of the crucifixion across his forehead, the favoured location for the cross of baptism.

verse, using the
alisée c. 1235-1245,
rary)

The Life of Christ

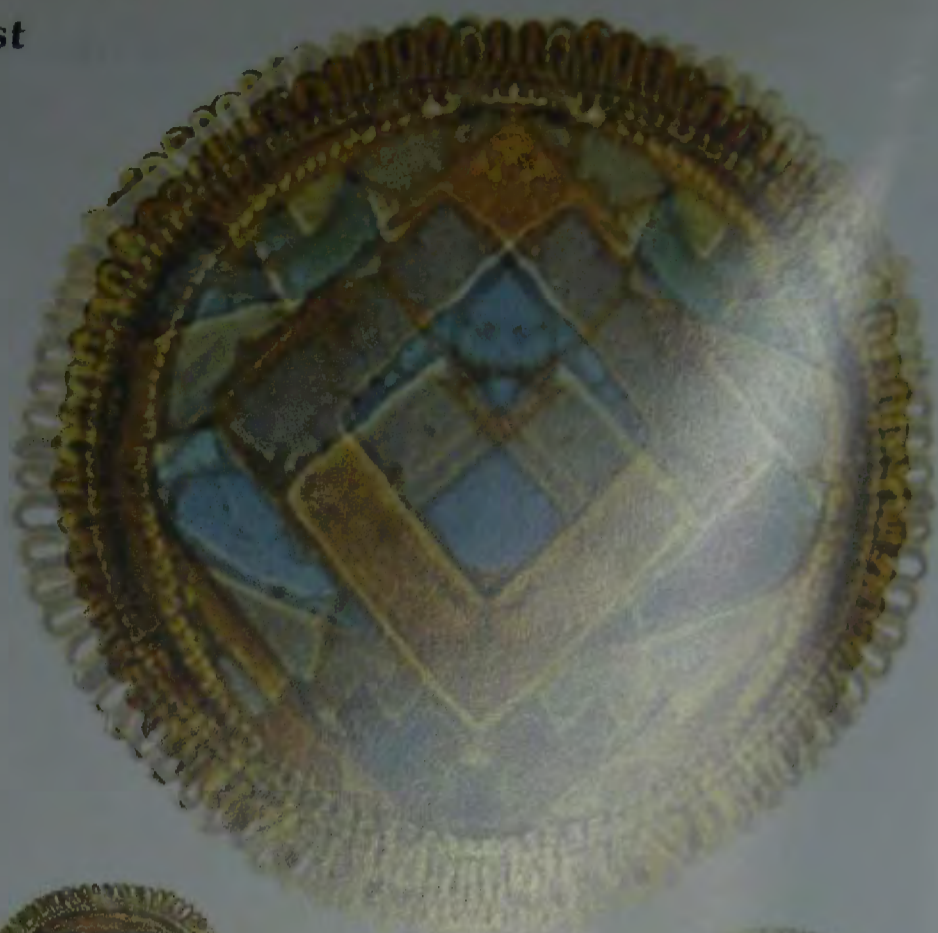

$\pm 133.2^\circ (2 \times 66.6^\circ)$



Plate 8. Composite picture showing; (a) Jesus sitting cross-legged beneath the compasses of the Freemason. (b) He carries the square of the Freemason, representing virtue and purity and is (c) carried away by the Bat God—meaning that Jesus was a Freemason who died a virtuous man.

(a)

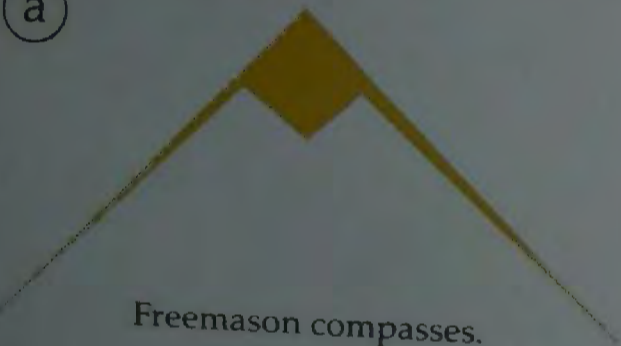

Freemason compasses.

(b)



Cross-legged Jesus with head and face on the cross carrying the square of the Freemason.

(c)



Bat God, symbol of death.

(d)



Christ as the Great Architect of the Universe, using the compasses of the Freemason. (Bible Moralisee c. 1235-1245, Laborde facsimile, 1211-27, British Library)

Plate 9. (a) sunspot loc seen with th of baptism

Death by Crucifixion

(a)

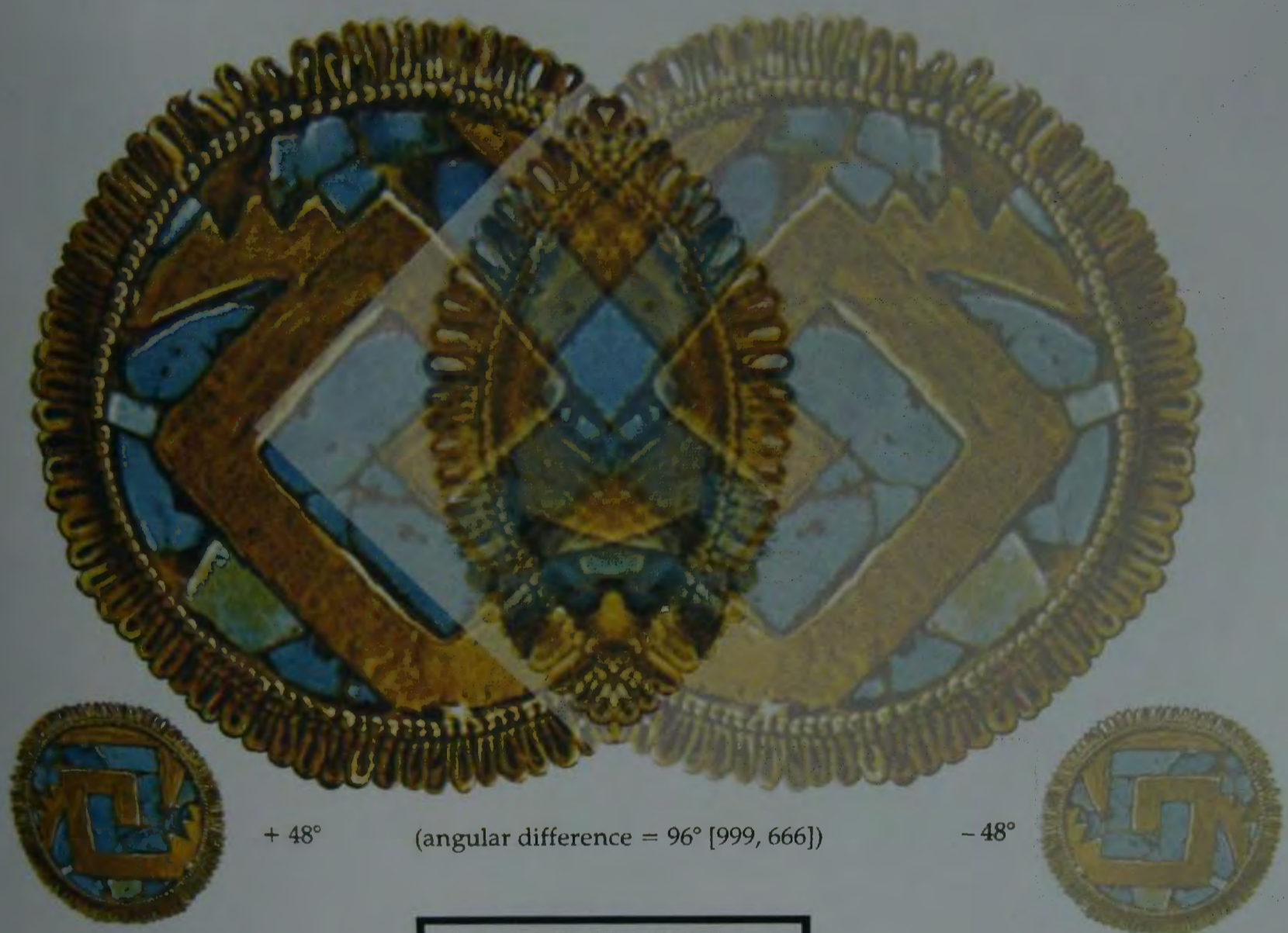

+ 48°

(angular difference = 96° [999, 666])

- 48°

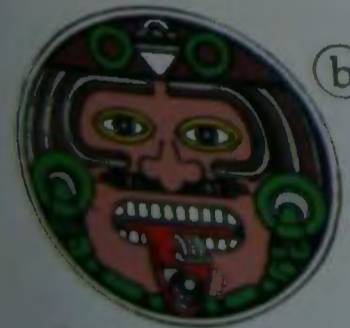

Sun God from Aztec Calendar stone.

(b)



Sun God from the Amazing Lid of Palenque.

(c)

Jesus as the Sun



Jesus, with a halo of sunspot loops. (*Bible Moralisee* c. 1235-1245, Laborde facsimile, 1911-27, British Library.)

(d)



Plate 9. (a) Composite picture showing Jesus as the Sun God, with an extended tongue, and sunspot loops on his head, inside a vesica piscis (the geometric symbol of Christianity). He is seen with the cross of the Crucifixion across his forehead, the favoured location for the cross of baptism.

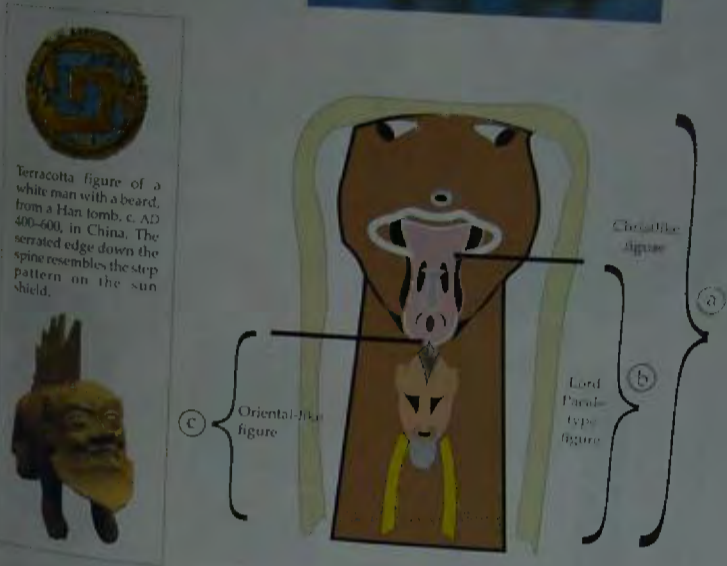

Plate 10. (a) and (c) Composite picture of a bat, the symbol of darkness and death, hanging from the Christian cross, revealing that Viracocha (plate 3) died on the cross. (b) and (c) The scene is carried by Xiuhtechutli, who carried the sacrificial brazier of cremation on his back. The Sun and Venus, representing God and Jesus, shine above his head. An Olmec head (d) an earlier incarnation of Viracocha, watches over him [inside the brazier, (e)] during the sacrifice.

Xiuhtechutli, Lord of Fire and Sacrifice
Xiuhtechutli was one and the same as Xipe Totec, the Lord of Sacrifice.

Christ on the Cross

Plate 11. An even closer examination of the composite of the bat hanging from the cross reveals more complex pictures inside the bat: (a) a Christlike figure; (b) a Lord Pacal-type figure and (c) an Oriental-like figure. [The images are much more persuasive when displayed on the computer using maximum zoom]. Thus a picture of Christ is shown dying on the cross. [To see the Christlike figure, gaze at the eyes, just below the hood, and wait for the picture to snap into consciousness].



Terracotta figure of a white man with a beard, from a Han tomb, c. AD 400-600, in China. The serrated edge down the spine resembles the step pattern on the sun shield.

Death on the Cross

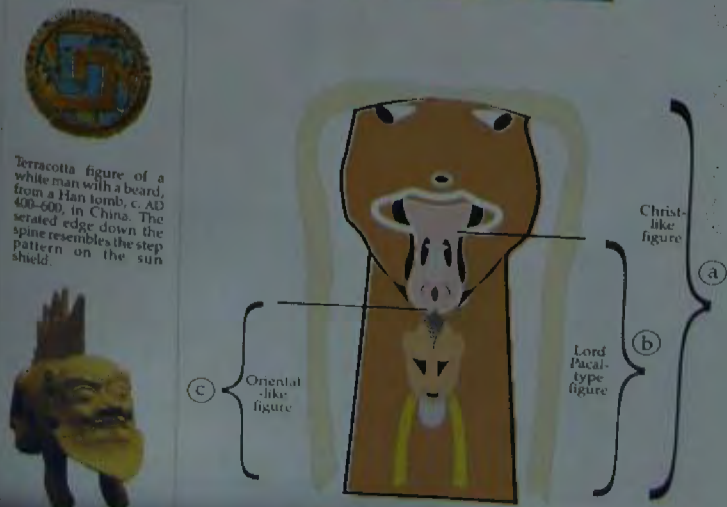

Plate 10. (a) and (c) Composite picture of a bat, the symbol of darkness and death, hanging from the Christian cross, revealing that Viracocha (plate 3) died on the cross. (b) and (c) The scene is carried by Xiuhtechutli who carried the sacrificial brazier of cremation on his back. The Sun and Venus, representing God and Jesus, shine above his head. An Olmec head (d) an earlier incarnation of Viracocha, watches over him [inside the brazier, (e)] during the sacrifice.

Xiuhtechutli, Lord of fire and sacrifice
Xiuhtechutli was one and the same as Xipe Totec, the Lord of Sacrifice.

Christ on the Cross

Plate 11. An even closer examination of the composite of the bat hanging from the cross reveals more complex pictures inside the bat: (a) A Christ-like figure. (b) A Lord Pacal-type figure and (c) An oriental-like figure. [The images are much more persuasive when displayed on the computer using maximum zoom]. Thus a picture of Christ is shown dying on the cross. [To see the Christ-like figure gaze at the eyes, just below the hood, and wait for the picture to snap into consciousness].



Terracotta figure of a white man with a beard, from a Han tomb, c. AD 400-600, in China. The serrated edge down the spine resembles the step pattern on the sun shield.

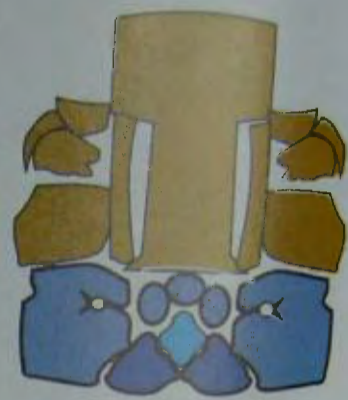

**Xiuhtechutli,
Lord of Fire and
Sacrifice**

Xiuhtechutli was one and the same as Xipe Totec, the Lord of Sacrifice.

Plate 10. (a) and (c) Composite picture of a bat, the symbol of darkness and death, hanging from the Christian cross, revealing that Viracocha (plate 3) died on the cross. (b) and (c) The scene is carried by Xiuhtechutli, who carried the sacrificial brazier of cremation on his back. The Sun and Venus, representing God and Jesus, shine above his head. An Olmec head (all an earlier incarnation of Viracocha, watches over him [inside the brazier, (e)] during the sacrifice.

Pla
tio
han
mo
bat
Lor
Ori
are
dis
max
of C
cross
figu
below
pictur
ness].

Terracotta
white man
from a Har
400-600, in
serrated ed
spine resem
pattern of
shield.



Christ on the Cross

Plate 11. An even closer examination of the composite of the bat hanging from the cross reveals more complex pictures inside the bat: (a) a Christlike figure; (b) a Lord Pacal-type figure and (c) an Oriental-like figure. [The images are much more persuasive when displayed on the computer using maximum zoom]. Thus a picture of Christ is shown dying on the cross. [To see the Christlike figure, gaze at the eyes, just below the hood, and wait for the picture to snap into consciousness].



Terracotta figure of a white man with a beard, from a Han tomb, c. AD 400-600, in China. The serrated edge down the spine resembles the step pattern on the sun shield.

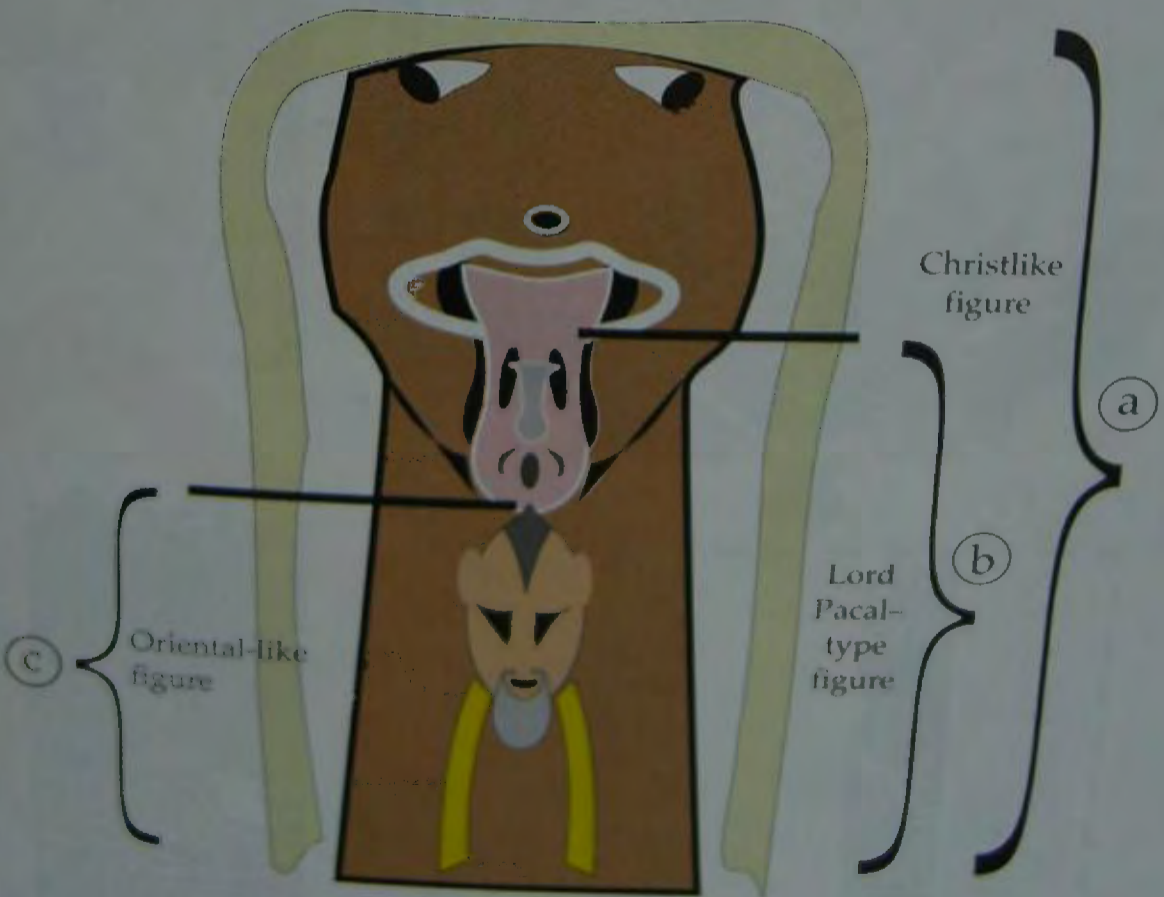

e

b

utli,
e and
ce
one and the
c, the Lord
h, hanging
and (c) The
on his back.
ec head (d),
during the

Christ on the Cross

Plate 11. An even closer examination of the composite of the bat hanging from the cross reveals more complex pictures inside the bat; (a) A Christ-like figure. (b) A Lord Pacal-type figure and (c) An oriental-like figure. [The images are much more persuasive when displayed on the computer using maximum zoom]. Thus a picture of Christ is shown dying on the cross. [To see the Christ-like figure gaze at the eyes, just below the hood, and wait for the picture to snap into consciousness].



Terracotta figure of a white man with a beard, from a Han tomb, c. AD 400-600, in China. The serrated edge down the spine resembles the step pattern on the sun shield.

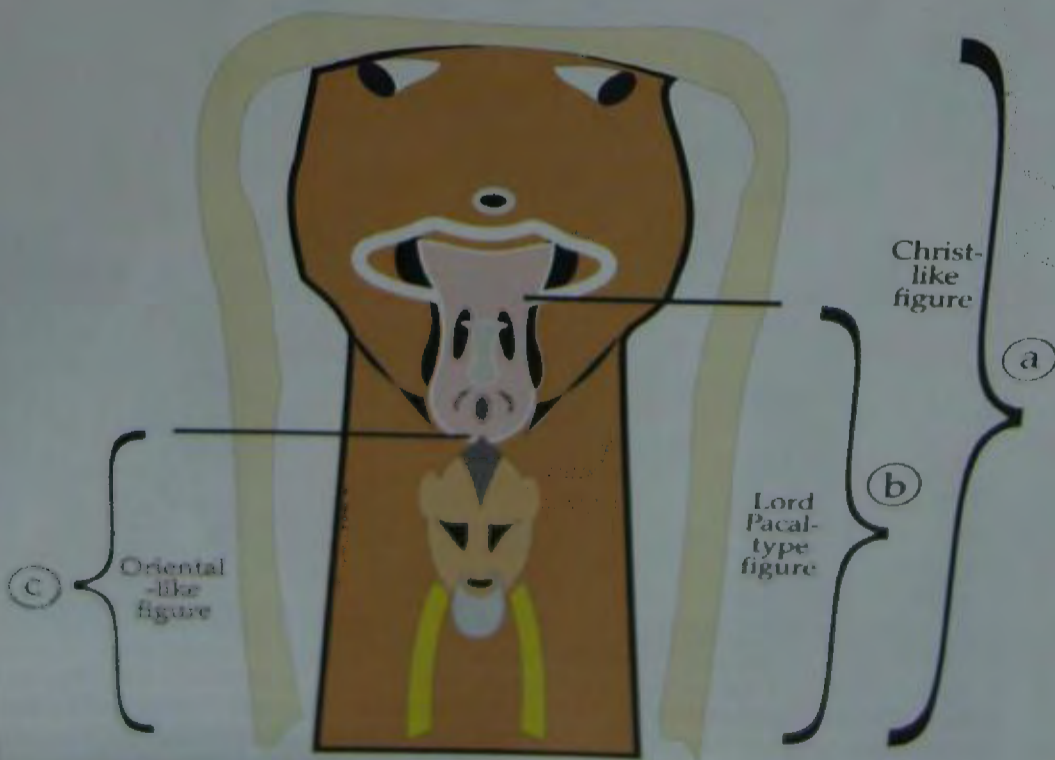

Death on the Cross

Olmec Head

(a)



(d)



(e)

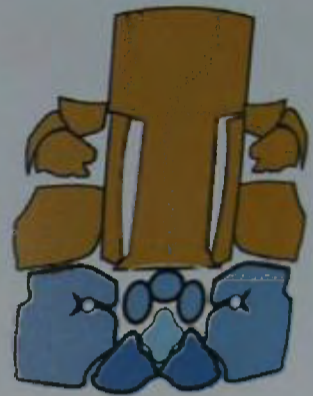

(b)



**Xiuhtechutli,
Lord of fire and
sacrifice**

Xiuhtechutli was one and the same as Xipe Totec, the Lord of Sacrifice.

(c)



Plate 10. (a) and (c) Composite picture of a bat, the symbol of darkness and death, hanging from the Christian cross, revealing that Viracocha (plate 3) died on the cross. (b) and (c) The scene is carried by Xiuhtechutli who carried the sacrificial brazier of cremation on his back. The Sun and Venus, representing God and Jesus, shine above his head. An Olmec head (d), an earlier incarnation of Viracocha, watches over him [inside the brazier, (e)] during the sacrifice.

F
e
c
h
re
pi
Cl
Pa
or
im
pe
on
ma
pic
dyi
the
the
hoo
pic
cons

Terra
white
from
400-6
serate
spine
patter
shield.

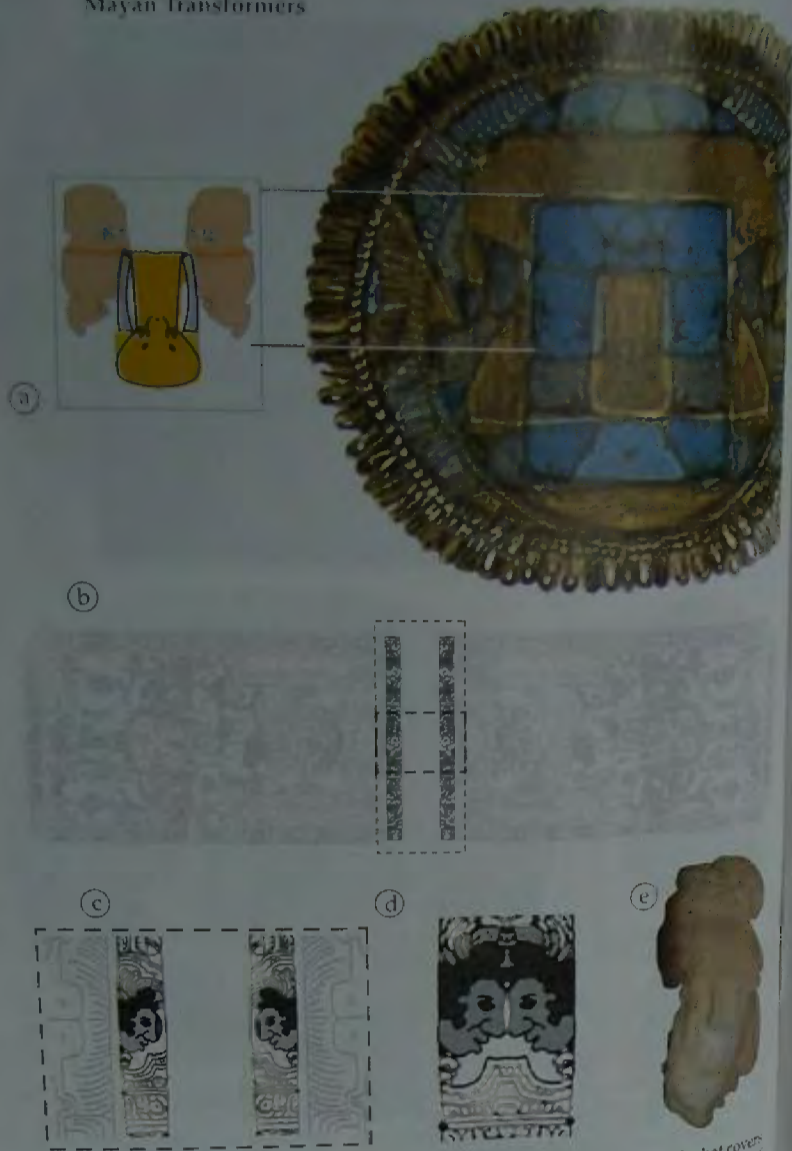

Plate 12. (a) Composite picture of Lord Pacal, as the twins (Venus) in profile. The bat covers both noses, referring to the secret (darkened) instructions encoded into the Amazing Lid of Palenque, (b), (c) and (d), that reveal the Maya transformer decoding process. (e) Stucco head from Pacal's tomb showing the same 'decoding' mark on the nose (emphasised).

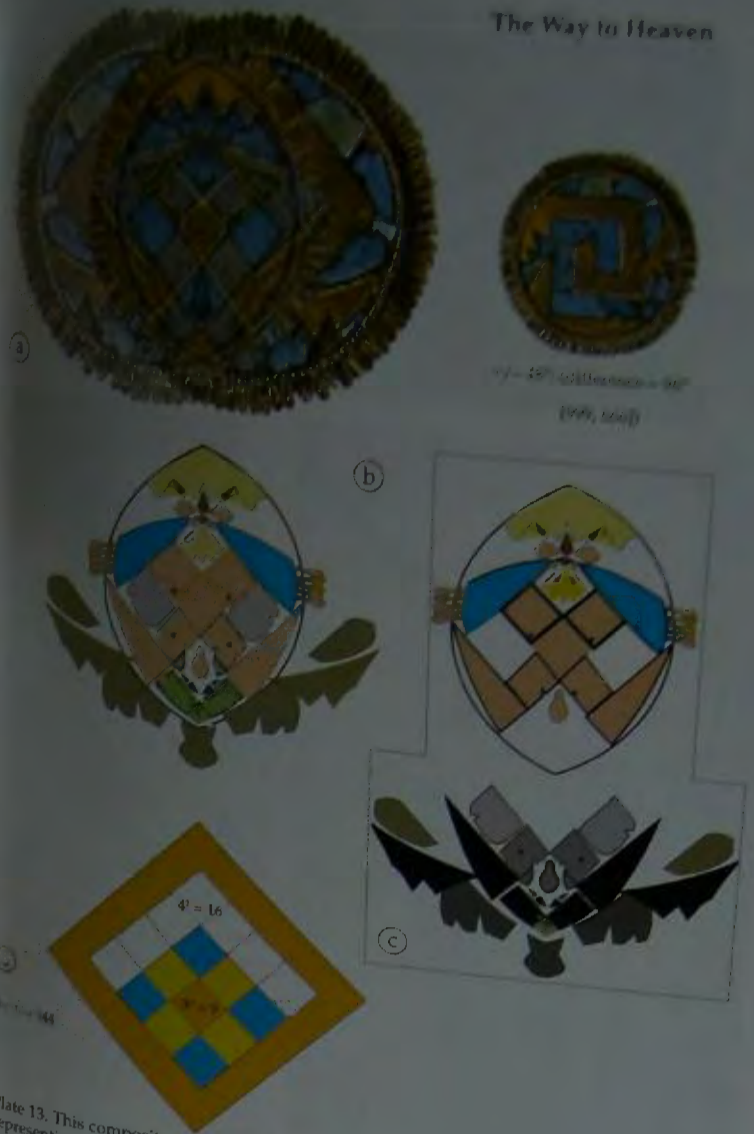

Plate 13. This composite picture shows (what appears to be) God, (b) his curved shoulders representing the Earth's horizon. His mouth appears to be the rising Sun, his eyes the rising star and the falling star. He opens his cloak and in so doing exposes his naked body and so is carried away by the bat (c); meaning that those who live by the body (a physical life) find only death and darkness, the place of the bat. (d) The 3, squared, and the 4, squared: $3^2 = 9$, $4^2 = 16$; $3^2 \times 4^2 = 144$, an abbreviation of the 144,000 from Revelation. The non-physical, who are numbered among the 144,000, find eternal life.

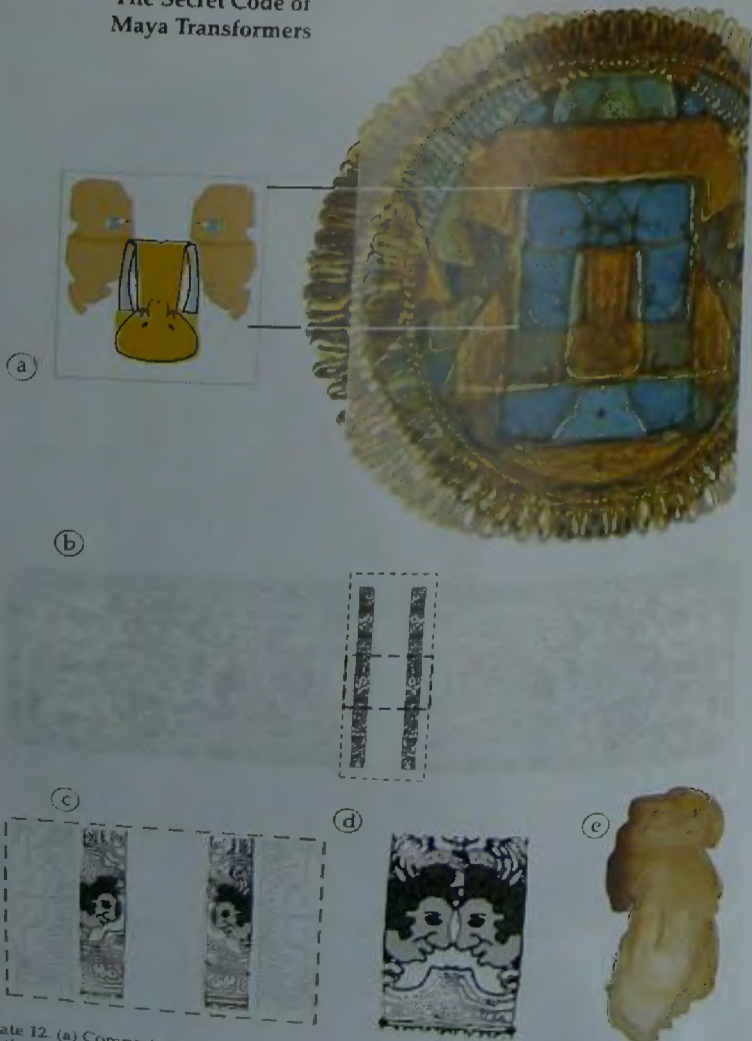

Plate 12. (a) Composite picture of Lord Pacal, as the twins (Venus) in profile. The bat covers both noses, referring to the secret (darkened) instructions encoded into the Amazing Lid of Palenque, (b), (c) and (d), that reveal the Maya Transformer decoding process. (e) Stucco head from Pacal's tomb showing the same 'decoding' mark on the nose (emphasised).

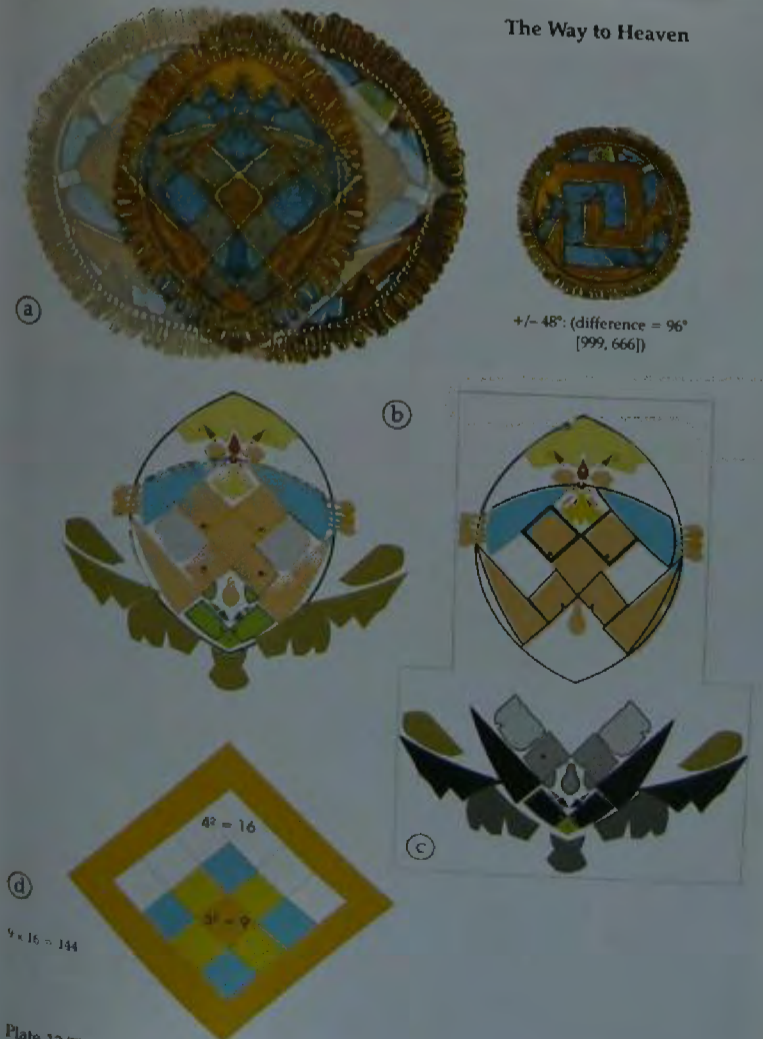

Plate 13. This composite picture shows (what appears to be) God, (b) his curved shoulders representing the Earth's horizon. His mouth appears to be the rising Sun, his eyes the rising star and the falling star. He opens his cloak and in so doing exposes his naked body and so is carried away by the bat (c); meaning that those who live by the body (a physical life) find only death and darkness, the place of the bat. (d) The three, squared, and the four, squared: $3^2 = 9$, $4^2 = 16$; $3^2 \times 4^2 = 144$, an abbreviation of the 144,000 from Revelation. The non-physical, who are numbered among the 144,000, find eternal life.

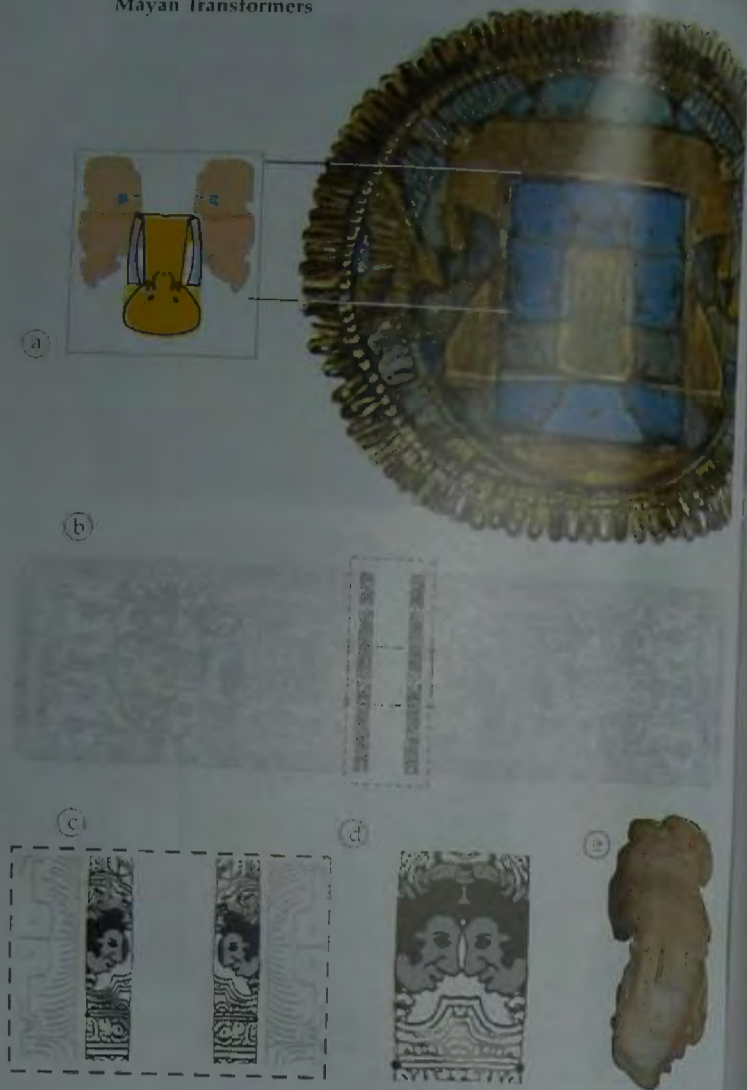

Plate 12. (a) Composite picture of Lord Pacal, as the twins (Venus) in profile. The bat covers both noses, referring to the secret (darkened) instructions encoded into the Amazing Lid of Palenque, (b), (c) and (d), that reveal the Maya transformer decoding process. (e) Stucco head from Pacal's tomb showing the same 'decoding' mark on the nose (emphasised).

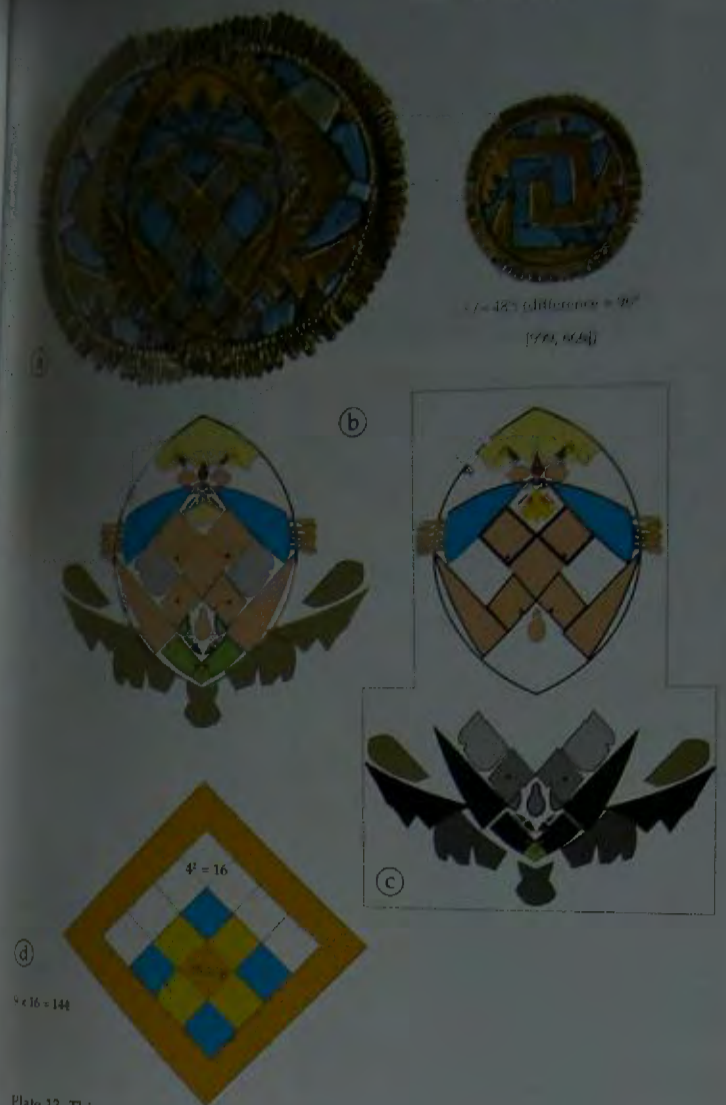

Plate 13. This composite picture shows (what appears to be) God, (b) his curved shoulders representing the Earth's horizon. His mouth appears to be the rising Sun, his eyes the rising star and the falling star. He opens his cloak and in so doing exposes his naked body and so is carried away by the bat, (c) meaning that those who live by the body (a physical life) find only death and darkness, the place of the bat. (d) The 3, squared, and the 4, squared: $3^2 = 9$, $4^2 = 16$; $3^2 \times 4^2 = 144$, an abbreviation of the 144,000 from Revelation. The non-physical, who are numbered among the 144,000, find eternal life.

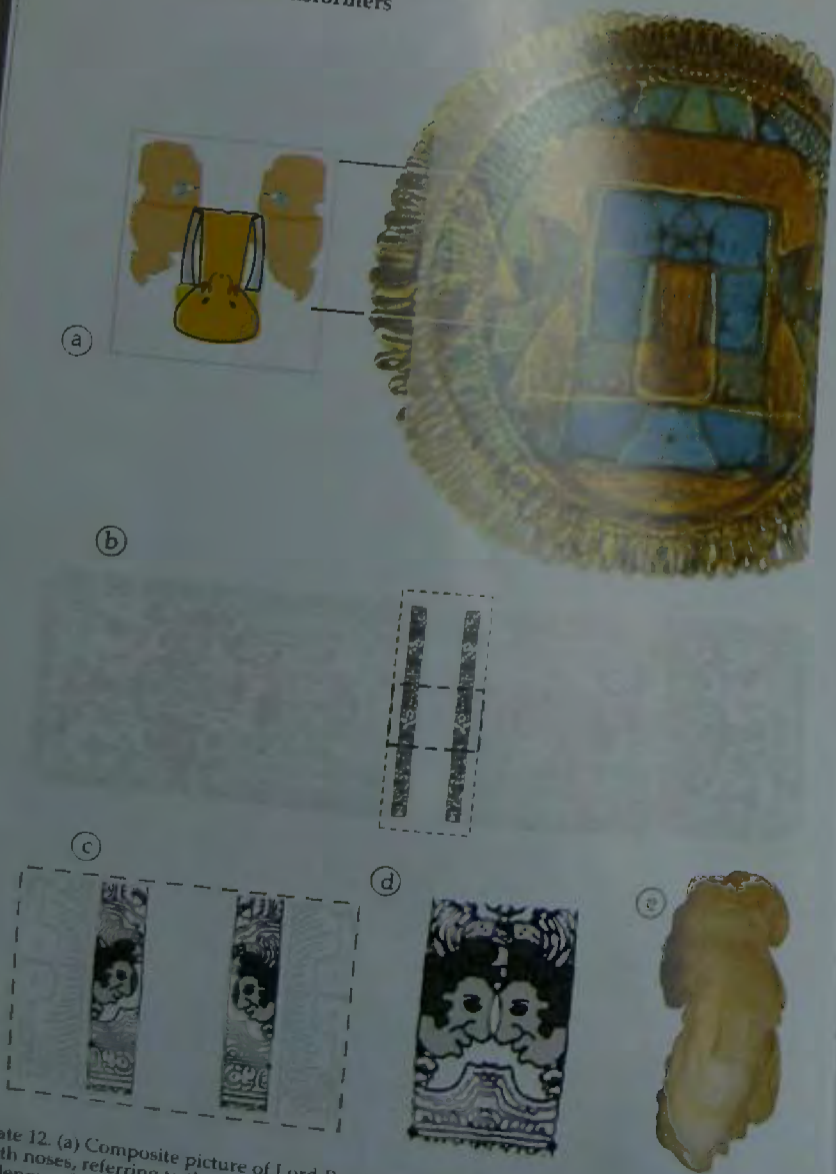

Plate 12. (a) Composite picture of Lord Pacal, as the twins (Venus) in profile. The bat covers both noses, referring to the secret (darkened) instructions encoded into the Amazing Lid of Palenque, (b), (c) and (d), that reveal the Maya Transformer decoding process. (e) Stucco head from Pacal's tomb showing the same 'decoding' mark on the nose (emphasised).



Plate 13. This composite picture shows (what appears to be) God, (b) his curved shoulders representing the Earth's horizon. His mouth appears to be the rising Sun, his eyes the rising star and the falling star. He opens his cloak and in so doing exposes his naked body and so is carried away by the bat, (c) meaning that those who live by the body (a physical life) find only death and darkness, the place of the bat. (d) The three, squared, and the four, squared; $3^2 = 9$, $4^2 = 16$; $3^2 \times 4^2 = 144$, an abbreviation of the 144,000 from Revelation. The non-physical, who are numbered among the 144,000, find eternal life.

The Secret Code of
Mayan Transformers

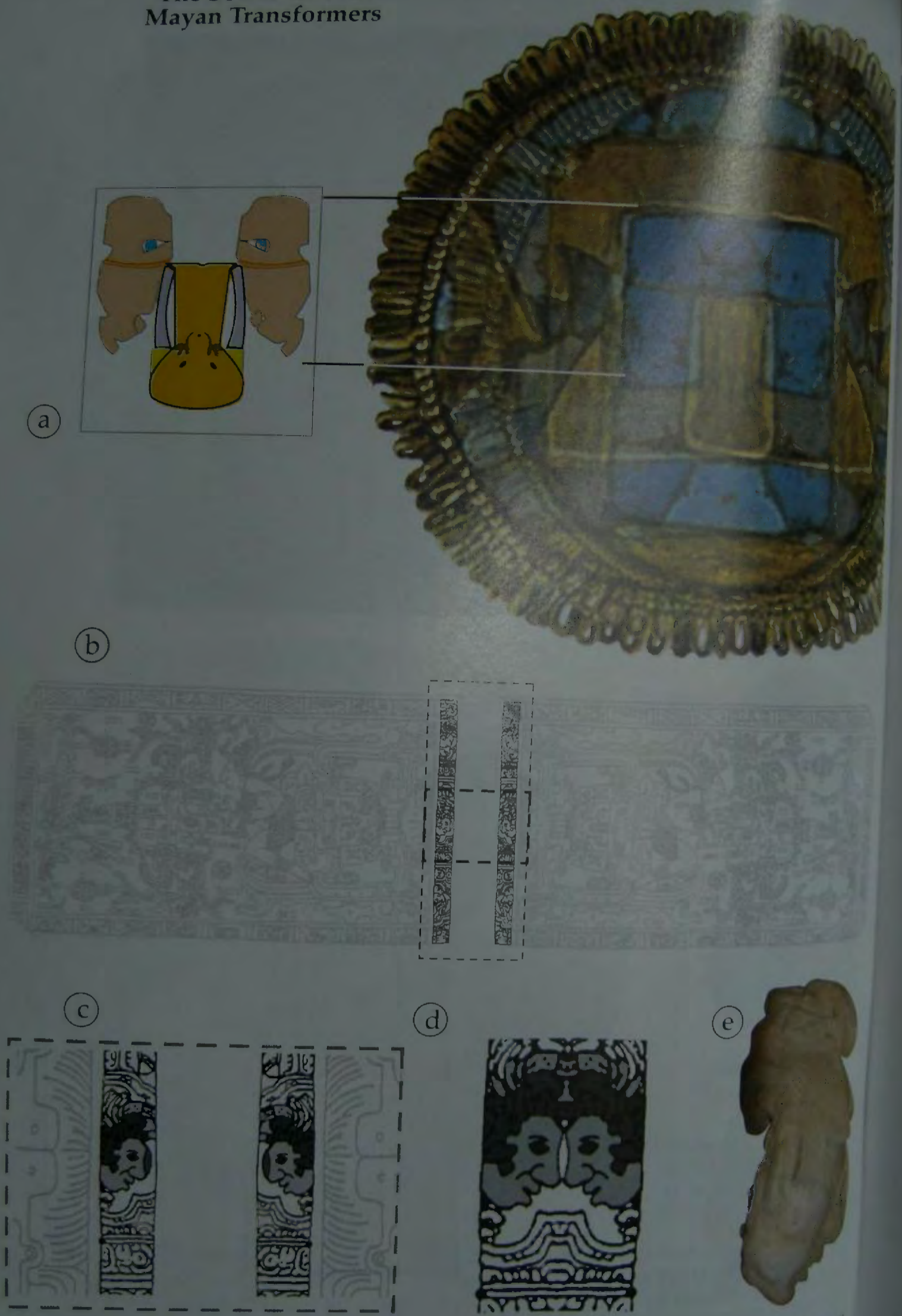

Plate 12. (a) Composite picture of Lord Pacal, as the twins (Venus) in profile. The bat covers both noses, referring to the secret (darkened) instructions encoded into the Amazing Lid of Palenque, (b), (c) and (d), that reveal the Mayan transformer decoding process. (e) Stucco head from Pacal's tomb showing the same 'decoding' mark on the nose (emphasised).

9 x 16 = 144

Plate 13. This representing the star and the face is carried away only death and $4^2 = 16$; $3^2 \times 4^2$ are numbered



②



④

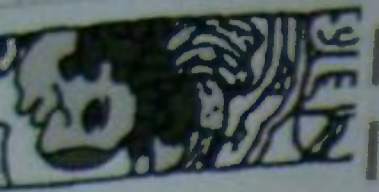

③

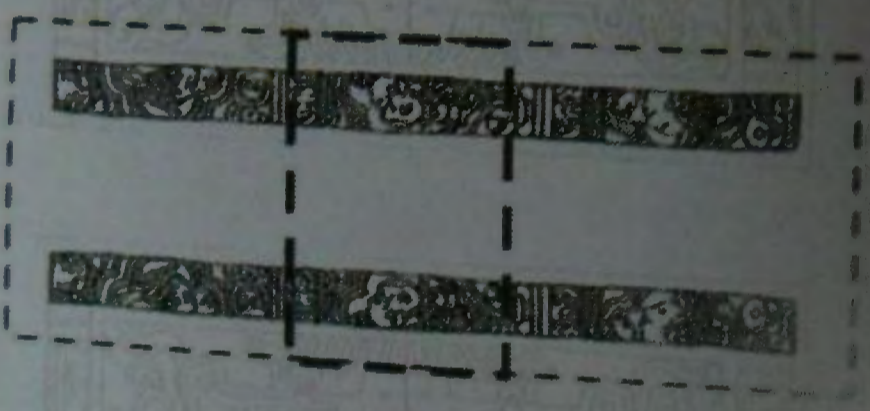
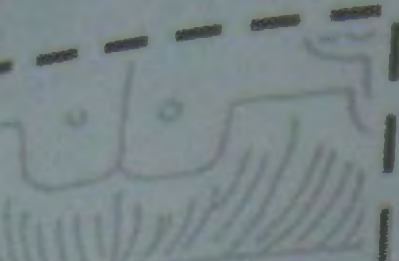

①



b



c

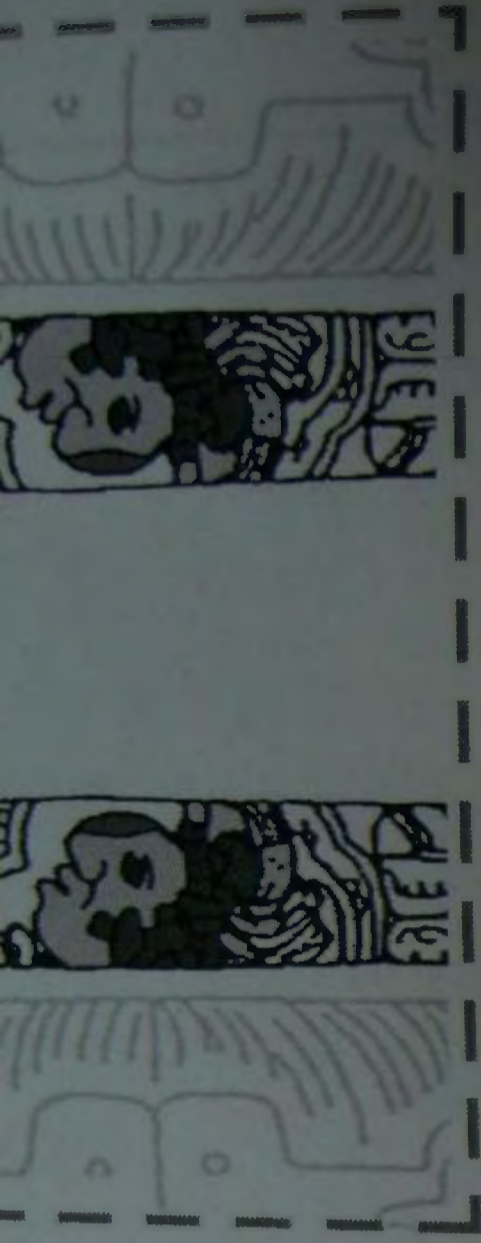

d



e



The Way to Heaven



+/- 48°: (difference = 96°)

[999, 666])

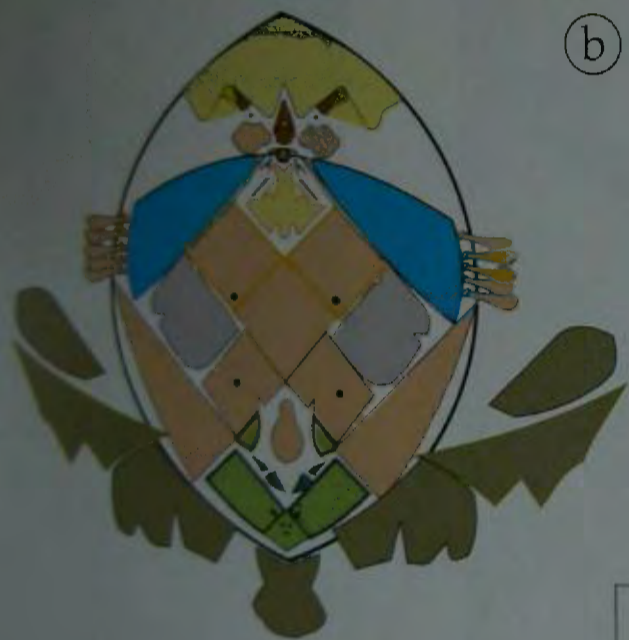

(a)

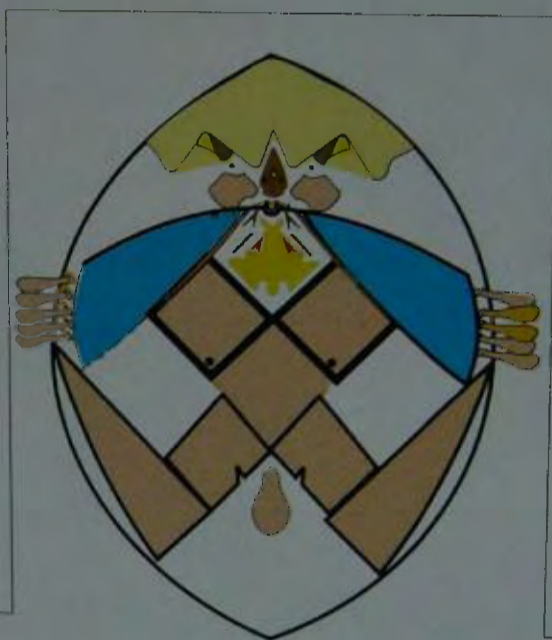

(c)

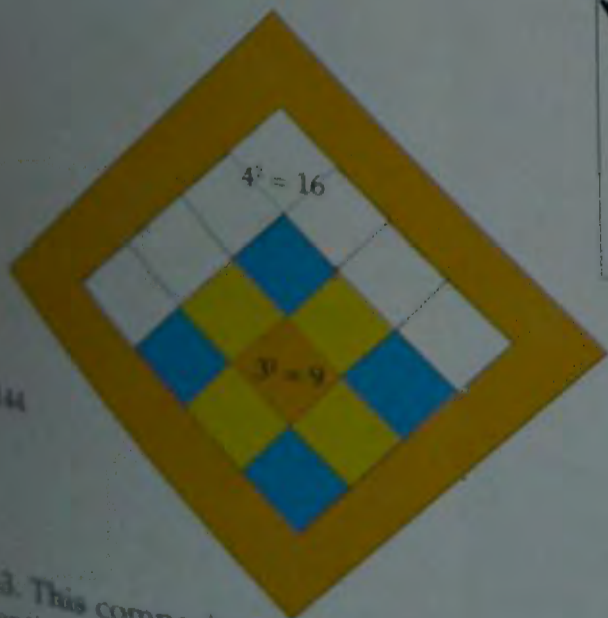

(d)

3 x 4 = 12

Plate 13. This composite picture shows (what appears to be) God, (b) his curved shoulders representing the Earth's horizon. His mouth appears to be the rising Sun, his eyes the rising star and the falling star. He opens his cloak and in so doing exposes his naked body and so is carried away by the bat, (c) meaning that those who live by the body (a physical life) find only death and darkness, the place of the bat. (d) The 3, squared, and the 4, squared: $3^2 = 9$, $4^2 = 16$; $3^2 \times 4^2 = 144$, an abbreviation of the 144,000 from Revelation. The non-physical, who are numbered among the 144,000, find eternal life.

le. The bat covers
e Amazing Lid of
rocess. (e) Stucco
emphasised).

The Way to Heaven



(a)



+/- 48°: (difference = 96°
[999, 666])



(b)



(c)

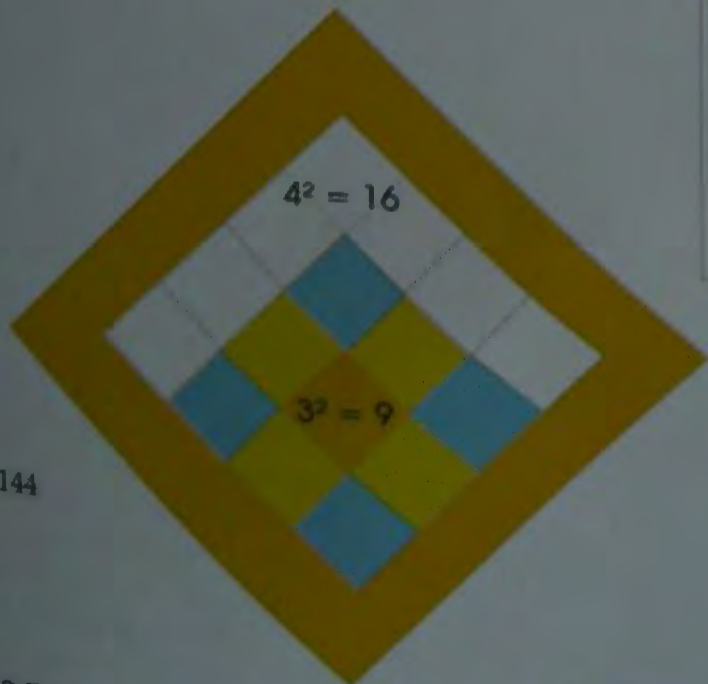

(d)

$9 \times 16 = 144$

Plate 13. This composite picture shows (what appears to be) God (b), his curved shoulders representing the Earth's horizon. His mouth appears to be the rising Sun, his eyes the rising star and the falling star. He opens his cloak and in so doing exposes his naked body and so is carried away by the bat (c); meaning that those who live by the body (a physical life) find only death and darkness, the place of the bat. (d) The three, squared, and the four, squared; $3^2 = 9$, $4^2 = 16$; $3^2 \times 4^2 = 144$, an abbreviation of the 144,000 from Revelation. The non-physical, who are numbered among the 144,000, find eternal life.

The Secret Code of Maya Transformers

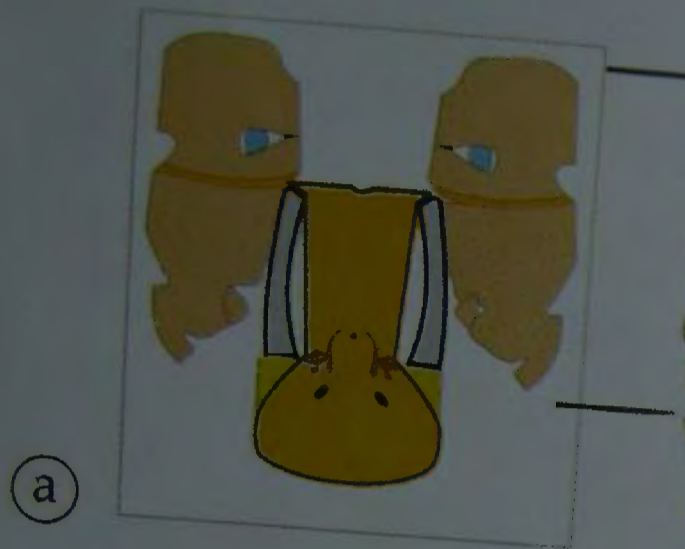

(b)

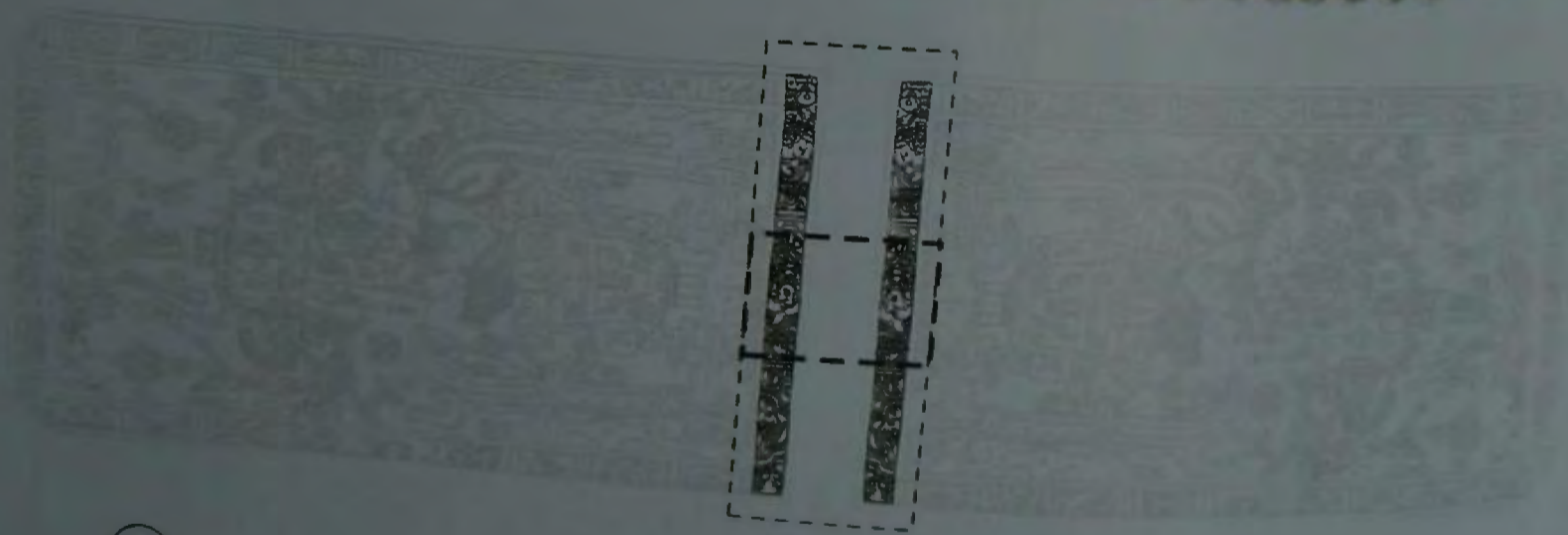

(c)



(d)

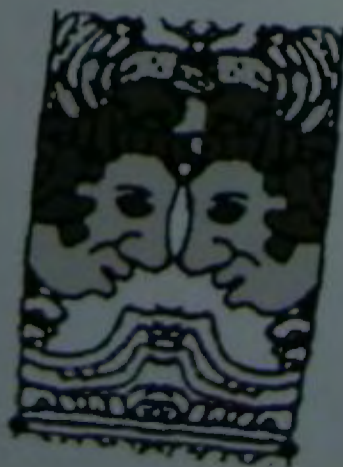

(e)



Plate 12. (a) Composite picture of Lord Pacal, as the twins (Venus) in profile. The bat covers both noses, referring to the secret (darkened) instructions encoded into the Amazing Lid of Palenque, (b), (c) and (d), that reveal the Maya Transformer decoding process. (e) Stucco head from Pacal's tomb showing the same 'decoding' mark on the nose (emphasised).

9 x 16 =

Plate 1
represe
star and
carried a
death a
4² = 16
are num



Plate 14. (a) Bronze Basse Yutz flagon, c. 400 BC, found during construction of a new road at Basse Yutz, France, in 1927. The design style typifies the second phase of the La Tène style of Celtic art. The spout and the base are circumscribed with coral inlay. The lid contains a beautiful semispherical bronze stud, detailed in (b), which is patterned with a tracery of bronze wire in-filled with coloured enamel (molten glass), the earliest known appearance of the technique in Europe. (c) Second vase of the pair [almost the same size as (a)].

Forty Years in the Wilderness
 The Patriarchal Period
 from the Exodus of Egypt
 into Canaan

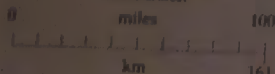

The route followed by the Israelites from Egypt through the desert to Canaan is identified by the red line.

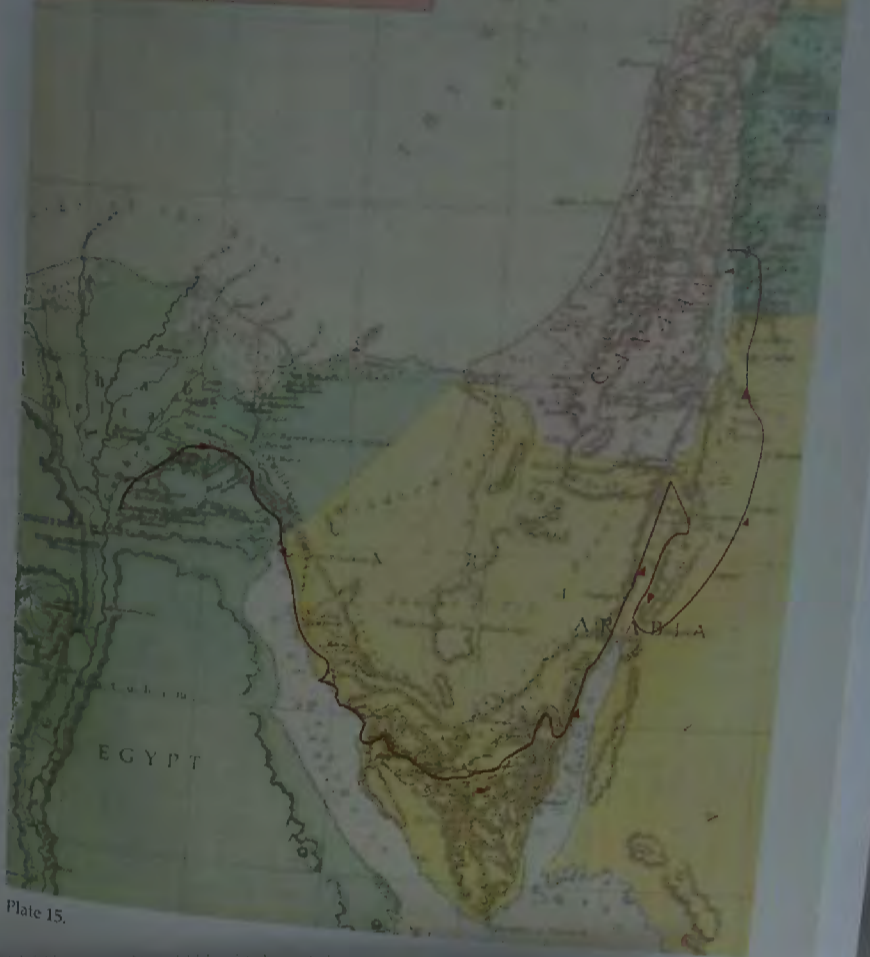

Plate 15.



Plate 14. (a) Bronze Basse Yutz flagon, c. 400 BC, found during construction of a new road at Basse Yutz, France, in 1927. The design style typifies the second phase of the La Tène style of Celtic art. The spout and the base are circumscribed with coral inlay. The lid contains a beautiful semispherical bronze stud, detailed in (b), which is patterned with a tracery of bronze wire in-filled with coloured enamel (molten glass), the earliest known appearance of the technique in Europe. (c) Second vase of the pair [almost the same size as (a)].

40 Years in the Wilderness

The Patriarchal Period
 from the Exodus of Egypt
 into Canaan

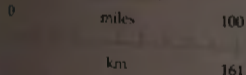

The route followed by the Israelites from Egypt through the desert to Canaan is identified by the red line.

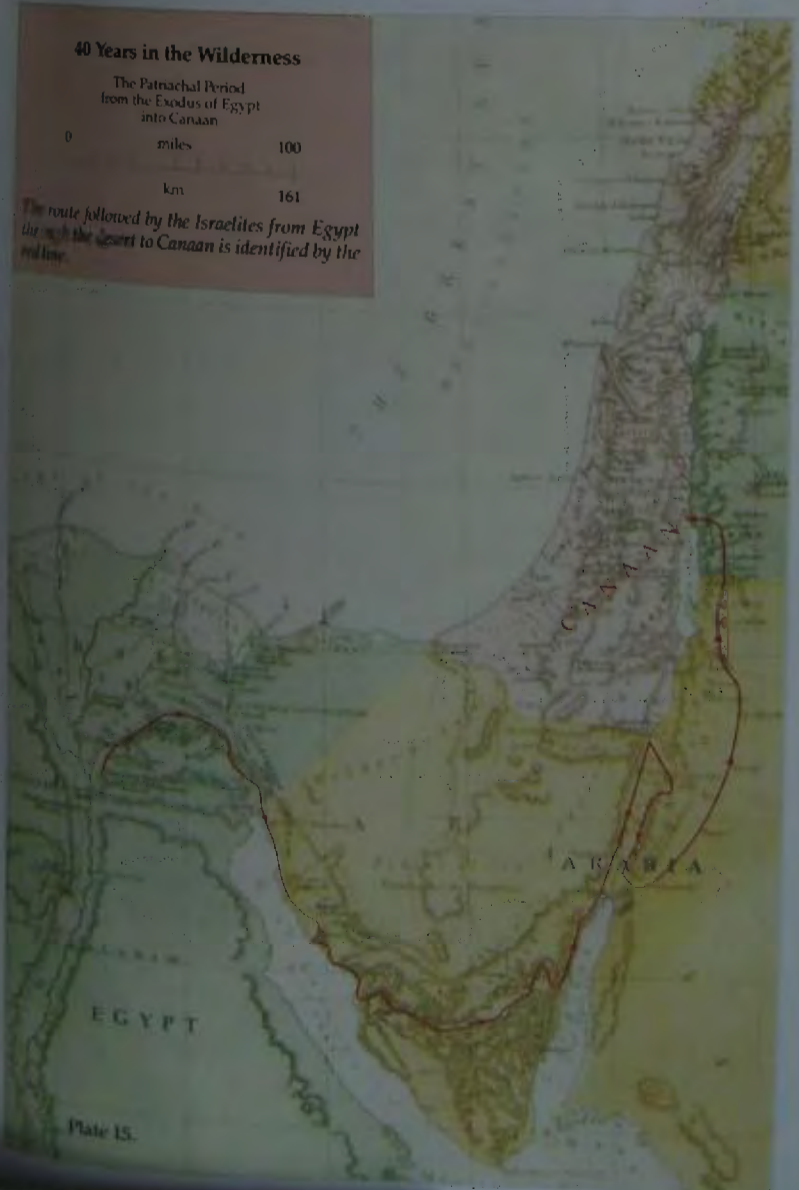

Plate 15.

The Basse Yutz Flagons, c. 400 BC



Plate 14. (a) Bronze Basse Yutz flagon, c. 400 BC, found during construction of a new road at Basse Yutz, France, in 1927. The design style typifies the second phase of the La Tène style of Celtic art. The spout and the base are circumscribed with coral inlay. The lid contains a beautiful semispherical bronze stud, detailed in (b), which is patterned with a tracery of bronze wire in-filled with coloured enamel (moulted glass), the earliest known appearance of the technique in Europe. (c) Second vase of the pair [almost the same size as (a)].

The Basse Yutz Flagons, c. 400 BC



Plate 14. (a) Bronze Basse Yutz flagon, c. 400 BC, found during construction of a new road at Basse Yutz, France, in 1927. The design style typifies the second phase of the La Tène style of Celtic art. The spout and the base are circumscribed with coral inlay. The lid contains a beautiful semispherical bronze stud, detailed in (b), which is patterned with a tracery of bronze wire in-filled with coloured enamel (molten glass), the earliest known appearance of the technique in Europe. (c) Second vase, of the pair (almost the same size as (a).)

The r
throu
red lin

The Long Journey of the Israelites

40 Years in the Wilderness

The Patriarchal Period
from the Exodus of Egypt
into Canaan

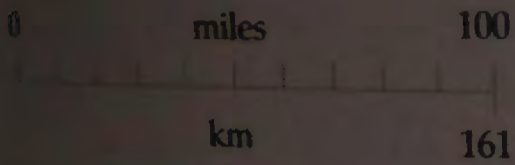

The route followed by the Israelites from Egypt through the desert to Canaan is identified by the red line.

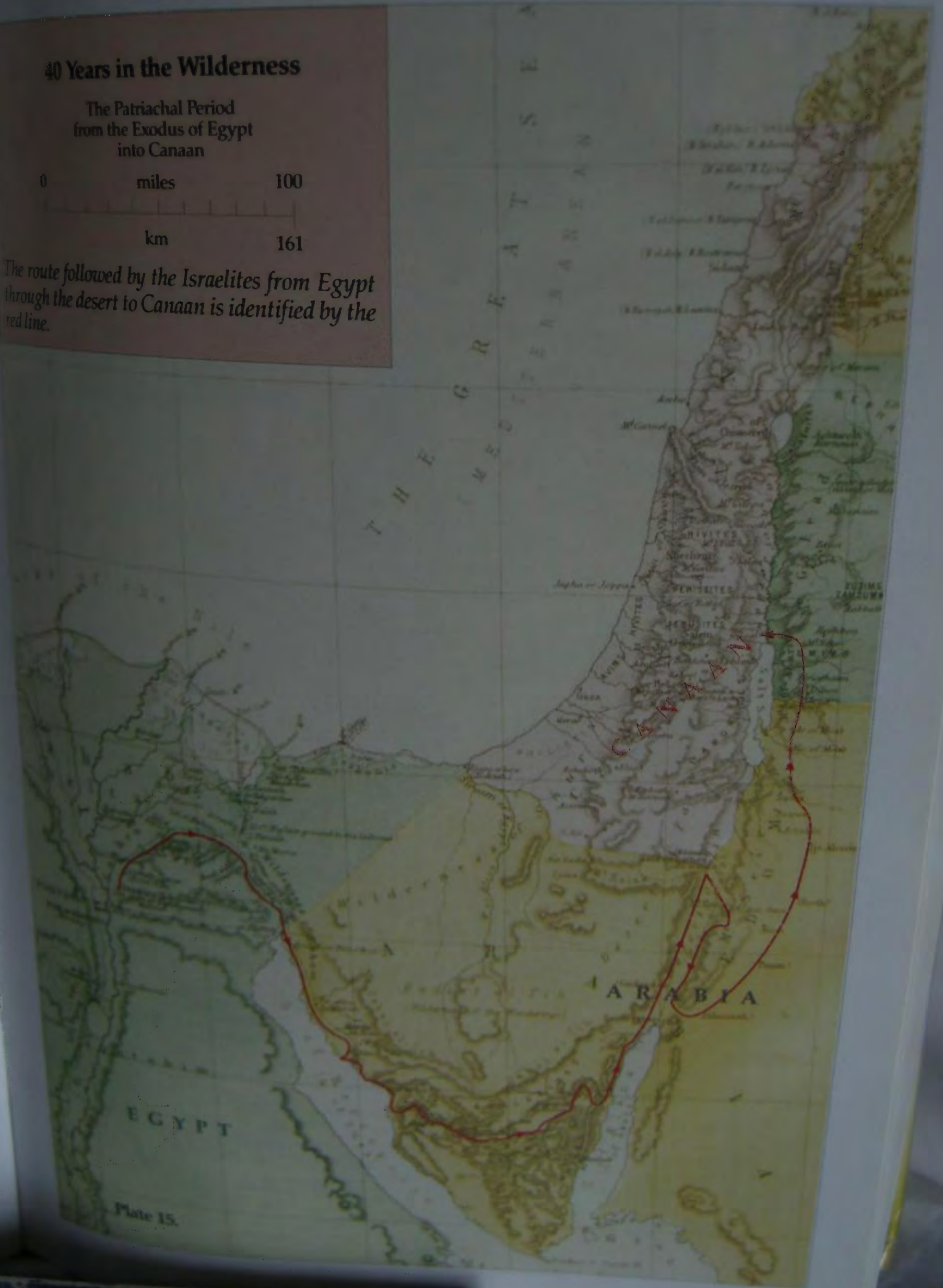

se
nd
ew
, in
yle
e of
art.
are
oral
s a
ical
(b).
th a
e in-
amel
rliest
f the
(c)
pair
(a.)

Forty Years in the Wilderness

The Patriarchal Period
from the Exodus of Egypt
into Canaan

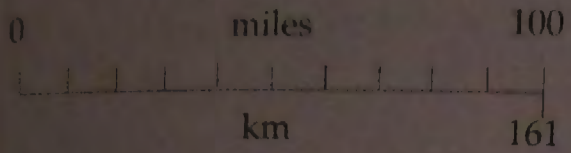

The route followed by the Israelites from Egypt through the desert to Canaan is identified by the red line.

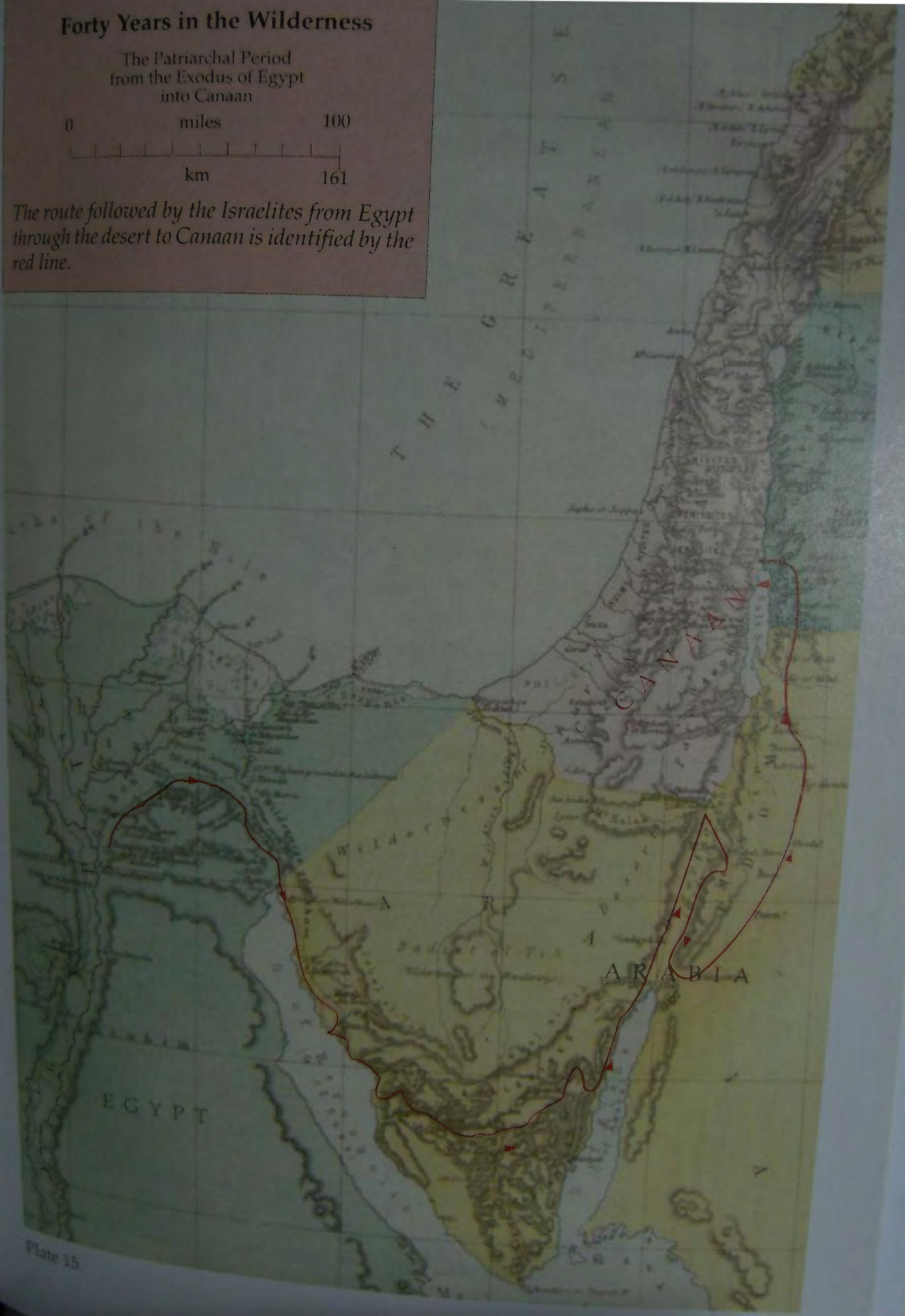



Plate 16. Initial page of the Gospel according to Saint Mark, from the Lindisfarne Gospels, known to date from AD 698. The names of the saints appear in Latinised Greek. The distinctive font is identical to the one used in the names of the saints carved on the Ardagh Chalice (discussed shortly), but there the names appear in Latin.

The Arthurian Legend of the Holy Grail



Plate 17. King Arthur (with crown and staff) together with eight of his knights (Summoned to the Quest by a Dame, Edward Burne-Jones, c. 1898, tapestry) commemorating the Last Supper. The mysterious empty seat, known as the *Siege Perilous* (next to Arthur) belonged to his 'right-hand man', the knight who would one day return with the Holy Grail. The inscription on the fabric over the empty chair reads 'CCCCXIII - Henniuis Peractis . Post . Natum . Uim . Nostrum . I . C . Oportet . Hanc . Sede . Compleri . In the year of our Lord AD 453 winter is over. It is right and proper for this seat to be occupied', meaning that 'the dark days are over, the Holy Grail [the cup of light] has been found'.



Plate 16. Initial page of the Gospel according to Saint Mark, from the Lindisfarne Gospels, known to date from AD 698. The names of the saints appear in Latinised-Greek. The distinctive font is identical to the one used in the names of the saints carved on the Ardagh Chalice (discussed shortly), but there the names appear in Latin.

The Arthurian Legend of the Holy Grail



Plate 17. King Arthur (with crown and staff) together with eight of his knights (Summoned to the Quest by a Dame, Edward Burne-Jones, c. 1898, tapestry) commemorating the Last Supper. The mysterious empty seat, known as the *Siege Perilous* (next to Arthur) belonged to his 'right-hand man', the knight who would one day return with the Holy Grail. The inscription on the fabric over the empty chair reads 'CCCCXIII - Henniuis Peractis . Post . Natum . Uim . Nostrum . I . C . Oportet . Hanc . Sede . Compleri . In the year of our Lord AD 453 winter is over. It is right and proper for this seat to be occupied', meaning that 'the dark days are over, the Holy Grail [the cup of light] has been found'.



Plate 16. Initial page of the Gospel according to Saint Mark, from the Lindisfarne Gospels, known to date from AD 698. The names of the saints appear in Latinised Greek. The distinctive font is identical to the one used in the names of the saints carved on the Ardagh Chalice (discussed shortly), but there the names appear in Latin.

The Lindisfarne Gospels



Plate 16. Initial-page of the Gospel according to Saint Mark, from the Lindisfarne Gospels, known to date from AD 698. The names of the saints appear in Latinised-Greek. The distinctive fount is identical to the one used in the names of the saints carved on the Ardagh Chalice (discussed shortly), but there the names appear in Latin.

The Arthurian Legend of the Holy Grail



Plate 17. King Arthur (with crown and staff) together with eight of his knights ('Summoned to the Quest by a Damsel', Edward Burne-Jones, c. 1898, tapestry) commemorating the Last Supper. The mysterious empty seat, known as the *Siege Perilous* (next to Arthur) belonged to his 'right-hand man', the knight who would one day return with the Holy Grail. The inscription on the fabric over the empty chair reads 'CCCCCLIII - Hiemius Peractis. Post . Natum . Umn . Nostrum - I - C . Oportet . Hanc . Sede . Compleri'; 'In the year of our Lord AD 453 winter is over. It is right and proper for this seat to be occupied, meaning that the dark days are over, the Holy Grail [the cup of light] has been found'.

The Arthurian Legend of the Holy Grail



Plate 17. King Arthur (with crown and staff) together with eight of his knights (Summoned to the Quest by a Damsel, Edward Burne-Jones, c. 1898, tapestry) commemorating the Last Supper. The mysterious empty seat, known as the *Siege Perilous* (next to Arthur), belonged to his 'right-hand man', the knight who would one day return with the Holy Grail. The inscription on the fabric over the empty chair reads 'CCCCCLIII - Hiemiuss for this seat to be occupied', meaning that 'the dark days are over, the Holy Grail [the cup of light] has been found'.
Peractis . Post . Natum . Umn . Nostrum - I - C . Oportet . Hanc . Sede . Compleri'; 'In the year of our Lord AD 453 winter is over. It is right and proper



Plate 18. This painting of 'Fair Rosamund' by John W. Waterhouse, 1916, is typical of those from the Pre-Raphaelite school of art that flourished in England from around 1850 to 1925. To the uninitiated it appears to show a simple picture of a princess waiting anxiously for her knight in shining armour. It actually contains secret information from the book of Ecclesiastes, in the Bible, explaining the mysteries of life—of Heaven and Hell (see figure 42).

The Arthurian Legend of The Holy Grail and Excalibur [the Sword of King Arthur]



Plate 19. King Arthur (seated centre) together with his nine knights at the Round Table (after a fifteenth-century manuscript). Arthur also appears in time lapse, in the left-hand panel window, drawing the legendary sword from the stone. The Holy Grail (flanked by two anthropomorphic golden dragon-angels, centre) is shown as a chalice, identical to the Ardargh Chalice, with light radiating through a samsite pall that carries the cross of Christ.



Plate 18. This painting, *Fair Rosamund*, by John W. Waterhouse, 1916, is typical of those from the Pre-Raphaelite school of art that flourished in England from around 1850 to 1925. To the uninitiated it appears to show a simple picture of a princess waiting anxiously for her knight in shining armour. It actually contains secret information from the book of Ecclesiastes, in the Bible, explaining the mysteries of life—of Heaven and Hell (see figure 42).

The Arthurian Legend of the Holy Grail and Excalibur [the Sword of King Arthur]



Plate 19. King Arthur (seated centre) together with his nine knights at the Round Table (after a fifteenth-century manuscript). Arthur also appears in time lapse, in the left-hand panel window, drawing the legendary sword from the stone. The Holy Grail (flanked by two anthropomorphic golden dragon-angels, centre) is shown as a chalice, identical to the Ardargh Chalice, with light radiating through a samsite pall that carries the cross of Christ.

The Arthurian Legend of The Holy Grail and Excalibur [the Sword of King Arthur]



Plate 19. King Arthur (seated centre) together with his nine knights at the Round Table (after a fifteenth-century manuscript). Arthur also appears in time lapse, in the left-hand panel window, drawing the legendary sword from the stone. The Holy Grail (flanked by two anthropomorphic golden dragon-angels, centre) is shown as a chalice, identical to the Ardargh Chalice, with light radiating through a samsite pall that carries the cross of Christ.

typical of those from
1850 to 1925. To the
of Ecclesiastes, in the
42).

The Arthurian Legend of the Holy Grail and Excalibur [the Sword of King Arthur]



Plate 19. King Arthur (seated centre) together with his nine knights at the Round Table (after a fifteenth-century manuscript). Arthur also appears in time lapse, in the left-hand-panel window, drawing the legendary sword from the stone. The Holy Grail (flanked by two anthropomorphic golden dragon-angels, centre) is shown as a chalice, identical to the Ardagh Chalice, with light radiating through a samite pall that carries the cross of Christ.



Plate 18. This painting of 'Fair Rosamund' by John W. Waterhouse, 1916, is typical of those from the Pre-Raphaelite school of art that flourished in England from around 1850 to 1925. To the uninitiated it appears to show a simple picture of a princess waiting anxiously for her knight in shining armour. It actually contains secret information from the book of Ecclesiastes, in the Bible, explaining the mysteries of life—of Heaven and Hell (see figure 42).

The Arthurian Legend

MA
Bests

The Secrets of the Pre-Raphaelites



Plate 18. This painting, *Fair Rosamund*, by John W. Waterhouse, 1916, is typical of those from the Pre-Raphaelite school of art that flourished in England from around 1850 to 1925. To the uninitiated it appears to show a simple picture of a princess waiting anxiously for her knight in shining armour. It actually contains secret information from the book of Ecclesiastes, in the Bible, explaining the mysteries of life—of Heaven and Hell (see figure 42).

The Arthurian Legend of the Holy Grail and Excalibur [the...]

The Secrets of the Tara Brooch (I)

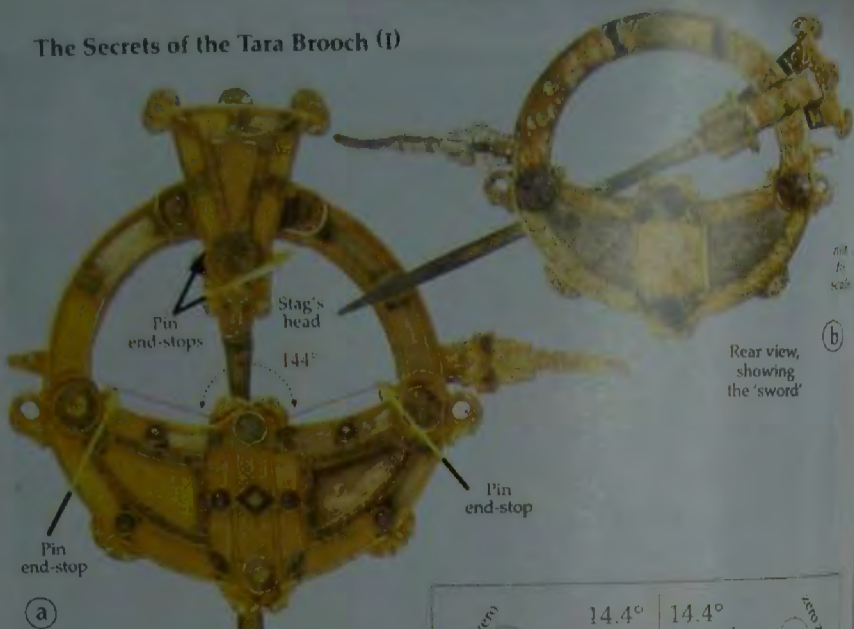

One end of the pin carries the head and antlers of a stag. The angle between the antlers measures 14.4°. The antler appendages each carry two circles (representing two zeros). A semicircle sits centred in the antler arrangement, representing a half-zero, shared by each antler. The sum of the arrangement hence amounts to 144,000, from Revelation, confirming the efficacy of the interpretation of measuring the angle between the pin end-stops on the main ring.

Plate 20. The Tara brooch contains secret knowledge of a very high scientific and spiritual order, associating its sister artefact, the Ardagh Chalice, with the same provenance. It also contains an account of the Arthurian legend of Excalibur. The stag's head can be slid around the ring until it reaches one of the pin end-stops. The pin (the sword) can then be removed from the stone set into the ring, by swinging it backwards, away from the brooch. Then the angle between the pin end-stops 144° [an abbreviation of the sacred number 144,000, from the book of Revelation in the Bible] can be measured. Hence the expression: 'he who draws the sword from the stone [who understands the meaning of the expression "144,000"] will be a King in Heaven' [from the Arthurian legend]. Clearly, the esoteric code of the Tara brooch was also broken by King Arthur, giving him knowledge of where to find the Grail. Later the story became part of the Arthurian so-called 'legend', which is actually fact.

The Tara Brooch (II—detail)



Plate 21. Tara brooch detail: (a) and (f) a pair of dragon heads; (b) dragon head safety chain buckle connector; (c) Buckle (connected to ring by hinge pin); (d) two glass human heads (black); (e) two entwined vulture heads; (g) dragon heads from the tomb; (h) four profile dragon heads; (i) and (j) bird/dragon heads.

The Secrets of the Tara Brooch (I)

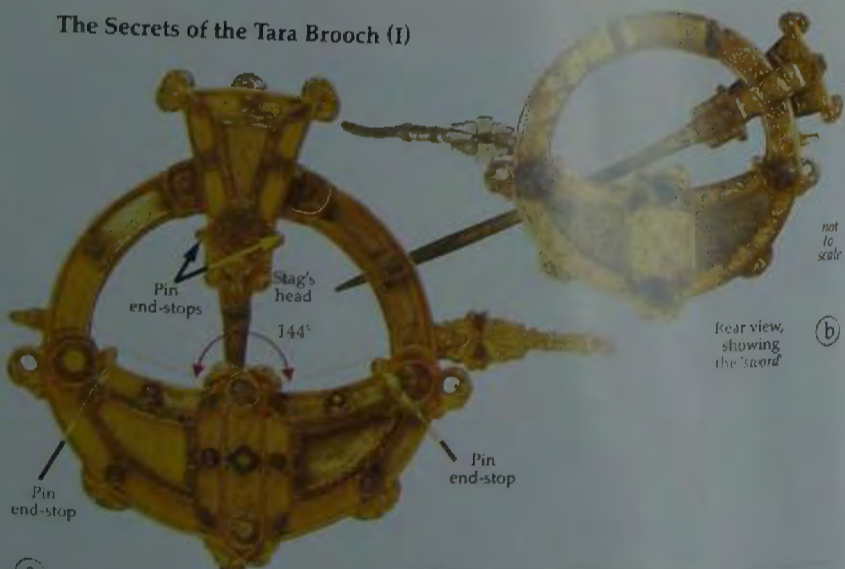

One end of the pin carries the head and antlers of a stag. The angle between the antlers measures 14.4°. The antler appendages each carry two circles (representing two zeros). A semicircle sits centred in the antler arrangement, representing a half-zero, shared by each antler. The sum of the arrangement hence amounts to 144,000, from Revelation, confirming the efficacy of the interpretation of measuring the angle between the pin end-stops on the main ring.

Plate 20. The Tara Brooch contains secret knowledge of a very high scientific and spiritual order, associating its sister artefact, the Ardagh Chalice, with the same provenance. It also contains an account of the Arthurian legend of Excalibur; the stag's head can be slid around the ring until it reaches one of the pin end-stops. The pin (the sword) can then be removed from the stone set into the ring, by swinging it backwards, away from the brooch. Then the angle between the pin end-stops 144° [an abbreviation of the sacred number 144,000, from the book of Revelation in the Bible] can be measured. Hence the expression: 'he who draws the sword from the stone [who understands the meaning of the expression "144,000"] will be a King in Heaven' [from the Arthurian legend]. Clearly, the esoteric code of the Tara brooch was also broken by King Arthur, giving him knowledge of where to find the Grail. Later the story became part of the Arthurian so-called 'legend', which is actually fact.

The Tara Brooch (II—detail)

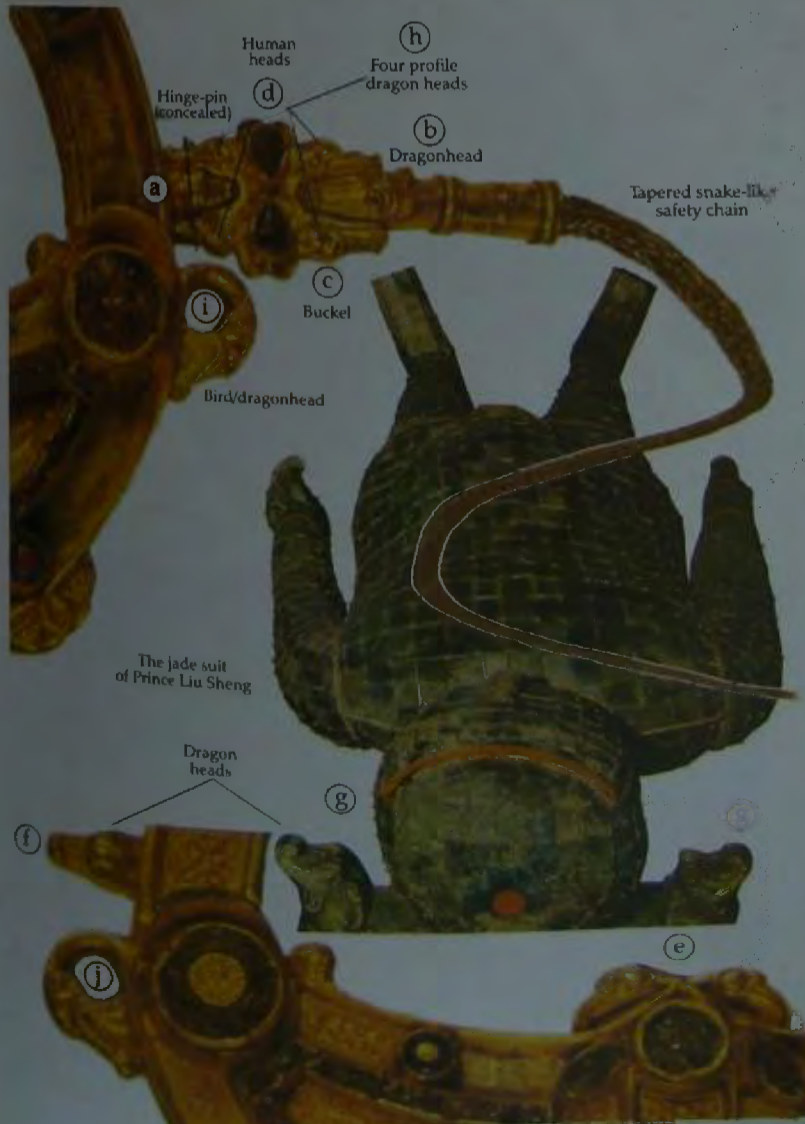

The Secrets of the Tara Brooch (I)



One end of the pin carries the head and antlers of a stag. The angle between the antlers measures 14.4°. The antler appendages each carry two circles (representing two zeros). A semicircle sits centred in the antler arrangement, representing a half-zero, shared by each antler. The sum of the arrangement hence amounts to 144,000, from Revelation, confirming the efficacy of the interpretation of measuring the angle between the pin end-stops on the main ring.

Plate 20. The Tara brooch contains secret knowledge of a very high scientific and spiritual order, associating its sister artefact, the Ardagh Chalice, with the same provenance. It also contains an account of the Arthurian legend of Excalibur. The stag's head can be slid around the ring until it reaches one of the pin end-stops. The pin (the sword) can then be removed from the stone set into the ring, by swinging it backwards, away from the brooch. Then the angle between the pin end-stops 144° [an abbreviation of the sacred number 144,000, from the book of Revelation in the Bible] can be measured. Hence the expression 'he who draws the sword from the stone [who understands the meaning of the expression "144,000"] will be a King in Heaven' [from the Arthurian legend]. Clearly, the esoteric code of the Tara brooch was also broken by King Arthur, giving him knowledge of where to find the Grail. Later the story became part of the Arthurian so-called 'legend', which is actually fact.

The Tara Brooch (II—detail)



Plate 21. Tara brooch detail: (a) and (f) a pair of dragon heads; (b) dragon head safety chain to buckle connector; (c) Buckle (connected to ring by hinge pin); (d) two glass human heads (back); (e) two entwined vulture heads; (g) dragon heads from the tomb of Prince Liu Sheng; (h) four profile dragon heads; (i) and (j) bird/dragon heads.

The Secrets of the Tara Brooch (I)

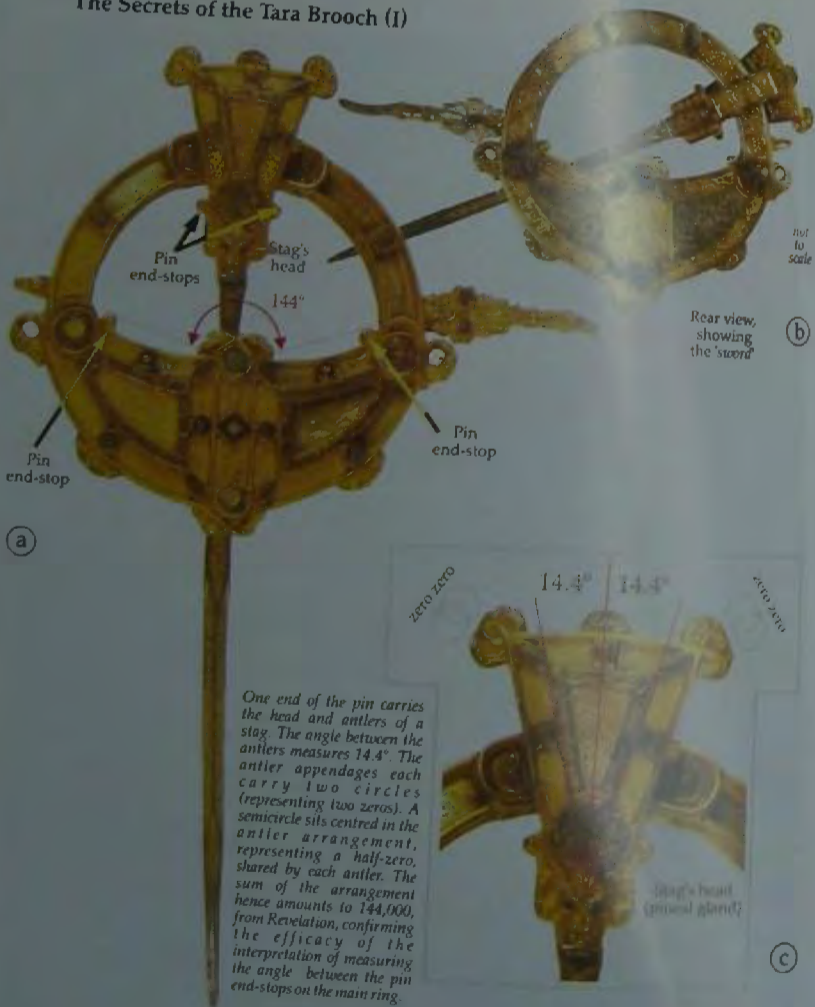

The Tara Brooch (II—detail)

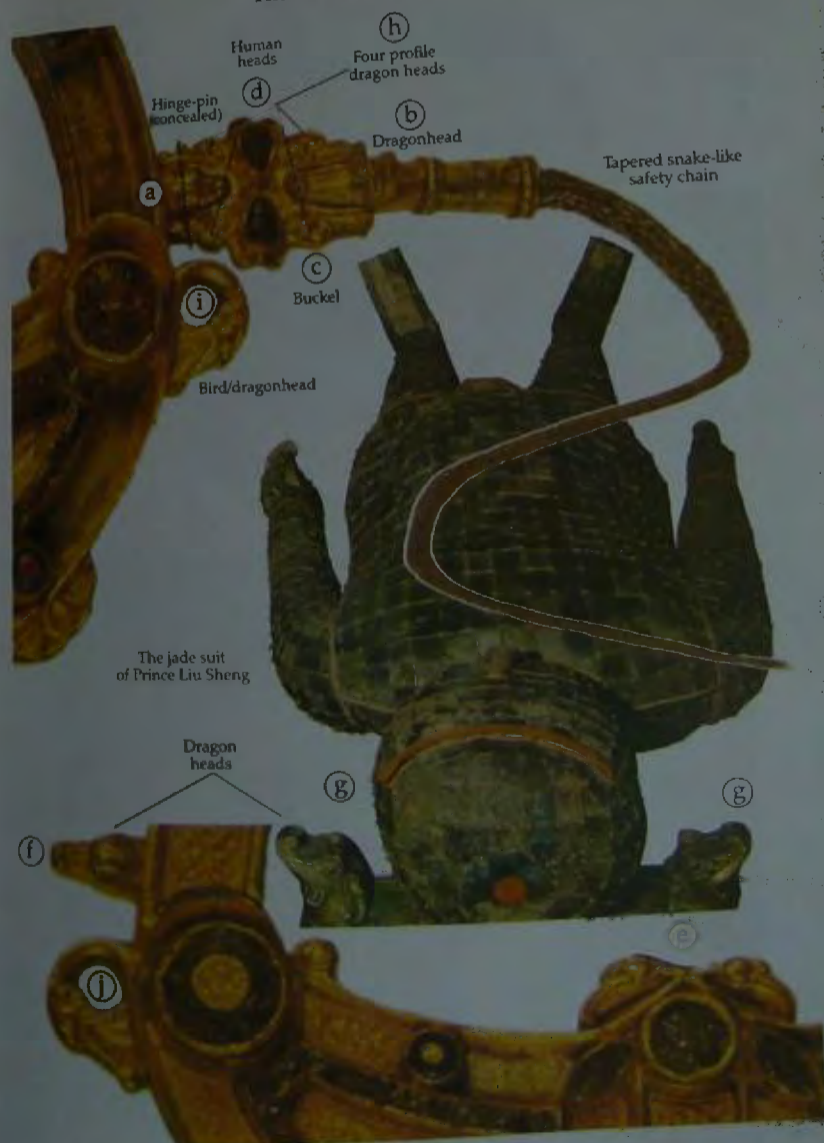
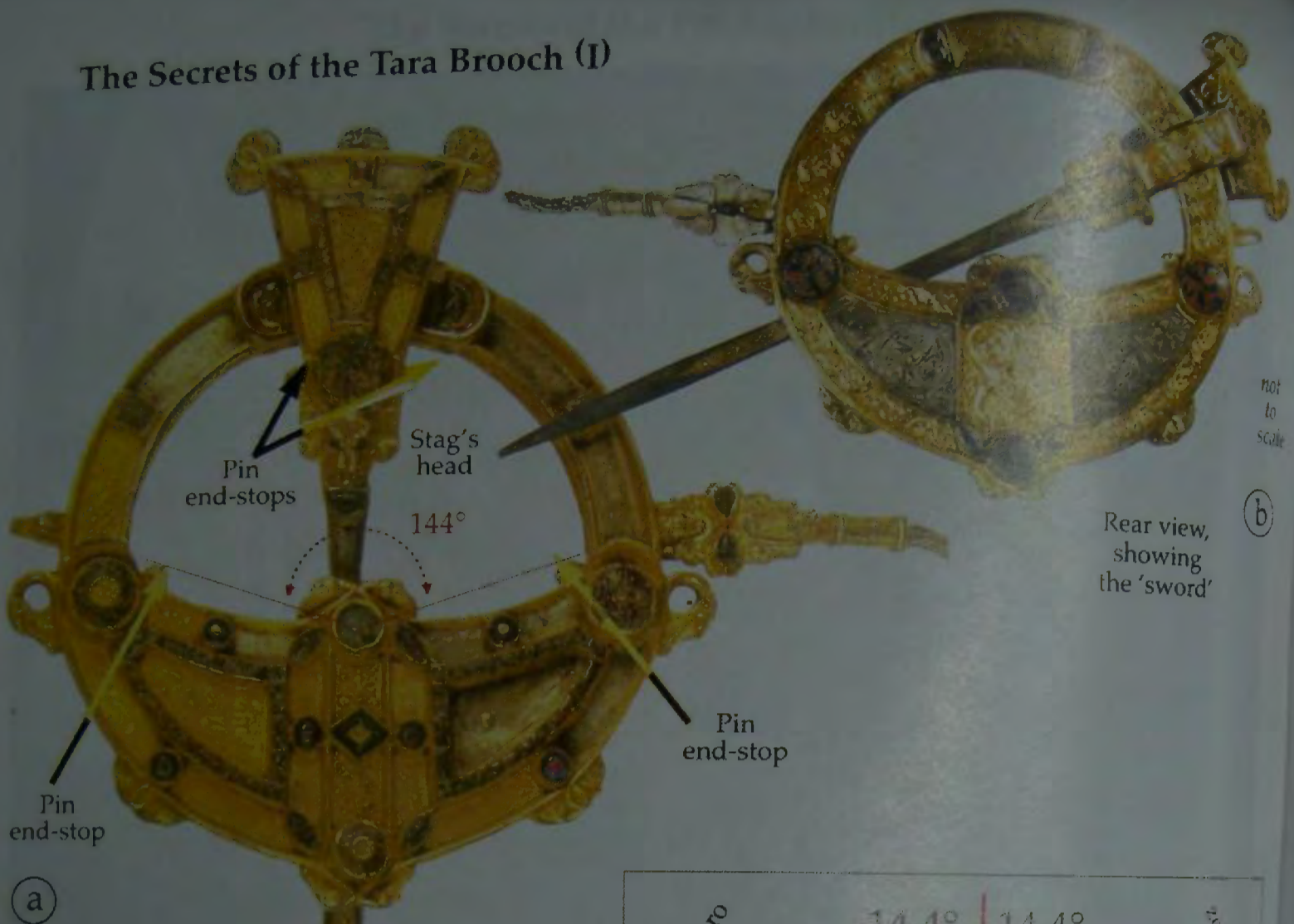

Plate 20. The Tara Brooch contains secret knowledge of a very high scientific and spiritual order, associating its sister artefact, the Ardagh Chalice, with the same provenance. It also contains an account of the Arthurian legend of Excalibur; the stag's head can be slid around the ring until it reaches one of the pin end-stops. The pin (the sword) can then be removed from the stone set into the ring, by swinging it backwards, away from the brooch. Then the angle between the pin end-stops 144° [an abbreviation of the sacred number 144,000, from the book of Revelation in the Bible] can be measured. Hence the expression 'he who draws the sword from the stone [who understands the meaning of the expression "144,000"] will be a King in Heaven' [from the Arthurian legend]. Clearly, the esoteric code of the Tara Brooch was also broken by King Arthur, giving him knowledge of where to find the Grail. Later the story became part of the Arthurian so-called 'legend', which is actually fact.

Plate 21. Tara Brooch detail; (a) and (f) A pair of dragon heads. (b) Dragonhead safety chain to buckle connector. (c) Buckle (connected to ring by hinge-pin). (d) Two glass human heads (back); (e) two entwined vulture heads; (g) Dragon heads from the tomb of Prince Liu Sheng; (h) four profile dragon heads; (i) and (j) bird/dragon heads.

The Secrets of the Tara Brooch (I)



(a)

(b)

One end of the pin carries the head and antlers of a stag. The angle between the antlers measures 14.4° . The antler appendages each carry two circles (representing two zeros). A semicircle sits centred in the antler arrangement, representing a half-zero, shared by each antler. The sum of the arrangement hence amounts to 144,000, from Revelation, confirming the efficacy of the interpretation of measuring the angle between the pin end-stops on the main ring.

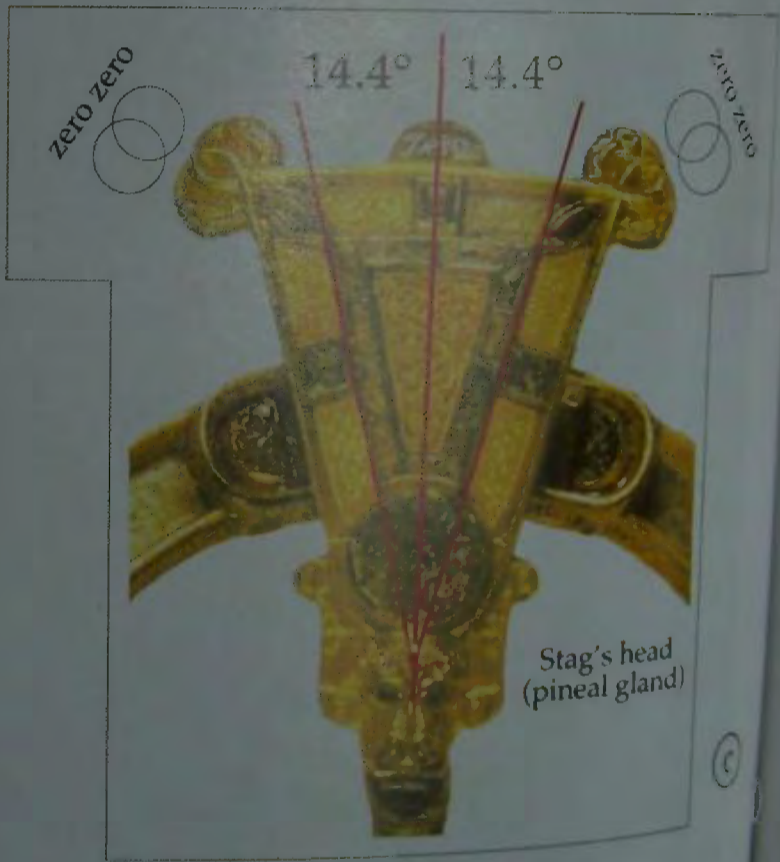

(c)

Plate 20. The Tara brooch contains secret knowledge of a very high scientific and spiritual order, associating its sister artefact, the Ardagh Chalice, with the same provenance. It also contains an account of the Arthurian legend of Excalibur. The stag's head can be slid around the ring until it reaches one of the pin end-stops. The pin (the sword) can then be removed from the stone set into the ring, by swinging it backwards, away from the brooch. Then the angle between the pin end-stops 144° [an abbreviation of the sacred number 144,000, from the book of Revelation in the Bible] can be measured. Hence the expression: 'he who draws the sword from the stone [who understands the meaning of the expression "144,000"] will be a King in Heaven' [from the Arthurian legend]. Clearly, the esoteric code of the Tara brooch was also broken by King Arthur, giving him knowledge of where to find the Grail. Later the story became part of the Arthurian so-called 'legend', which is actually fact.

Plate 21. Tara brooch detail to buckle connector; (c) B (black); (e) two entwined; (f) four profile dragon he

The Secrets of the Tara Brooch (I)

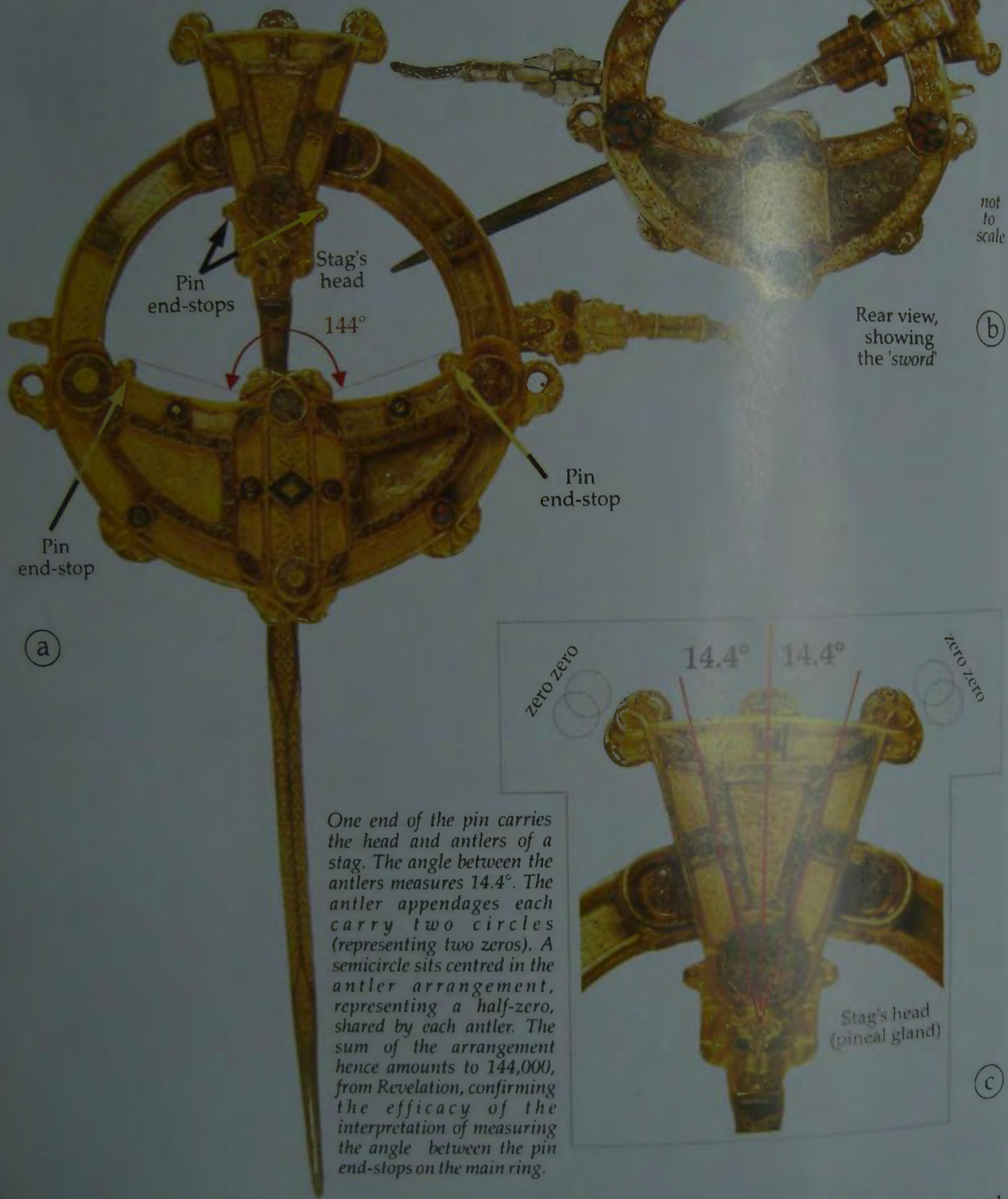

One end of the pin carries the head and antlers of a stag. The angle between the antlers measures 14.4° . The antler appendages each carry two circles (representing two zeros). A semicircle sits centred in the antler arrangement, representing a half-zero, shared by each antler. The sum of the arrangement hence amounts to 144,000, from Revelation, confirming the efficacy of the interpretation of measuring the angle between the pin end-stops on the main ring.

Plate 20. The Tara Brooch contains secret knowledge of a very high scientific and spiritual order, associating its sister artefact, the Ardagh Chalice, with the same provenance. It also contains an account of the Arthurian legend of Excalibur; the stag's head can be slid around the ring until it reaches one of the pin end-stops. The pin (the sword) can then be slid around from the stone set into the ring, by swinging it backwards, away from the brooch. Then the angle between the pin end-stops 144° [an abbreviation of the sacred number 144,000, from the book of Revelation in the Bible] can be measured. Hence the expression 'he who draws the sword from the stone [who understands the meaning of the expression '144,000'] will be a King in Heaven [from the Arthurian legend]. Clearly, the esoteric code of the Tara Brooch was also broken by King Arthur, giving him knowledge of where to find the Grail. Later the story became part of the Arthurian so-called 'legend', which is actually fact.

Plate 21
buckle
(black).
(h) Four

The Tara Brooch (II—detail)

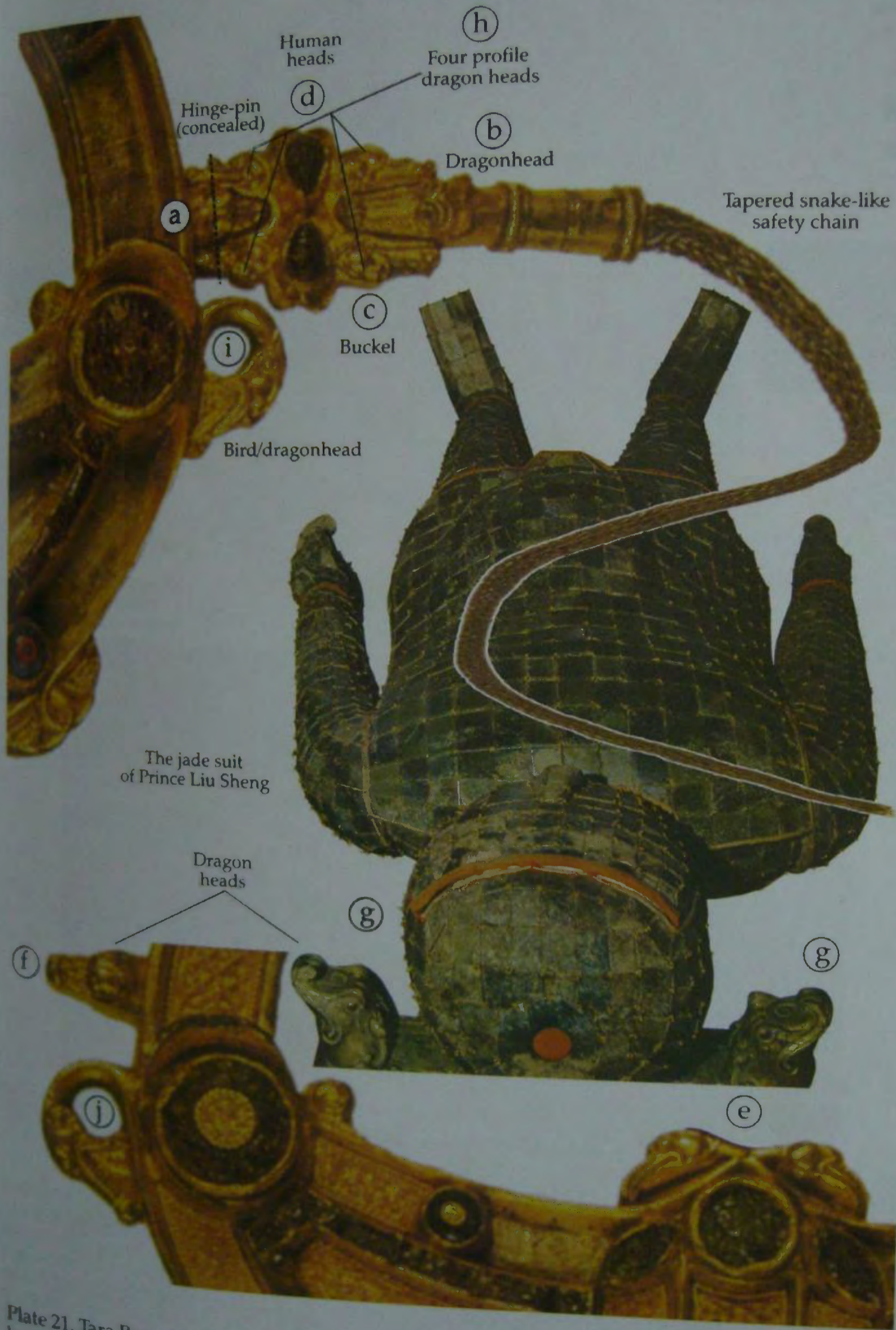
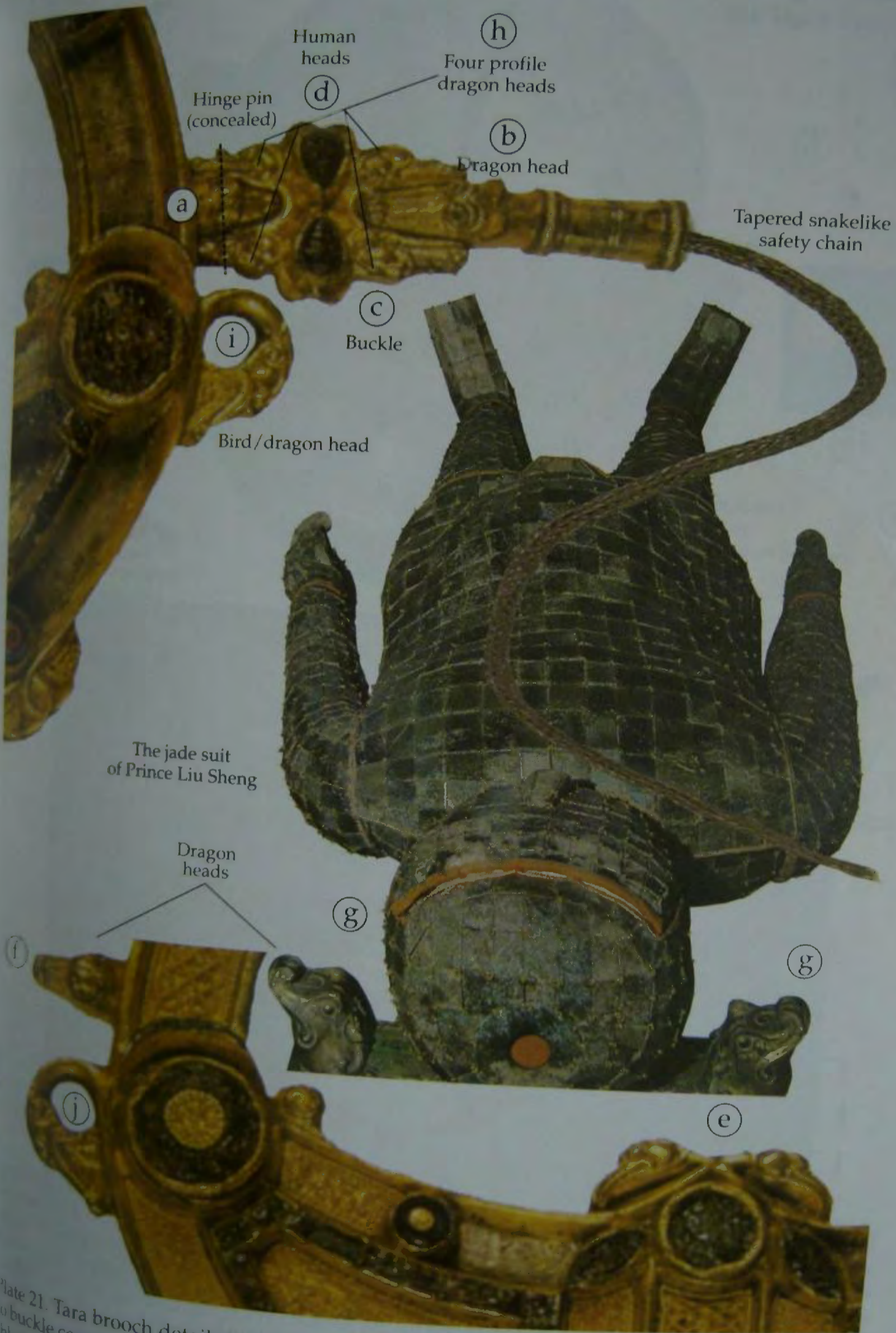

Plate 21. Tara Brooch detail; (a) and (f) A pair of dragon heads. (b) Dragonhead safety chain to buckle connector. (c) Buckle (connected to ring by hinge-pin). (d) Two glass human heads (black). (e) Two entwined vulture heads. (g) Dragon heads from the tomb of Prince Liu Sheng. (h) Four profile dragon heads. (i) and (j) Bird/dragon heads.

The Tara Brooch (II—detail)



The jade suit of Prince Liu Sheng

Plate 21. Tara brooch detail: (a) and (f) a pair of dragon heads; (b) dragon head safety chain to buckle connector; (c) Buckle (connected to ring by hinge pin); (d) two glass human heads (black); (e) two entwined vulture heads; (g) dragon heads from the tomb of Prince Liu Sheng; (h) four profile dragon heads; (i) and (j) bird/dragon heads.

not to scale

front view, showing 'sword'

zero zero

head gland)

and spiritual enance. It also be slid around n be removed ooch. Then the 144,000, from he who draws '144,000"] will he Tara brooch Grail. Later the

The Secrets of Tara Brooch (III)

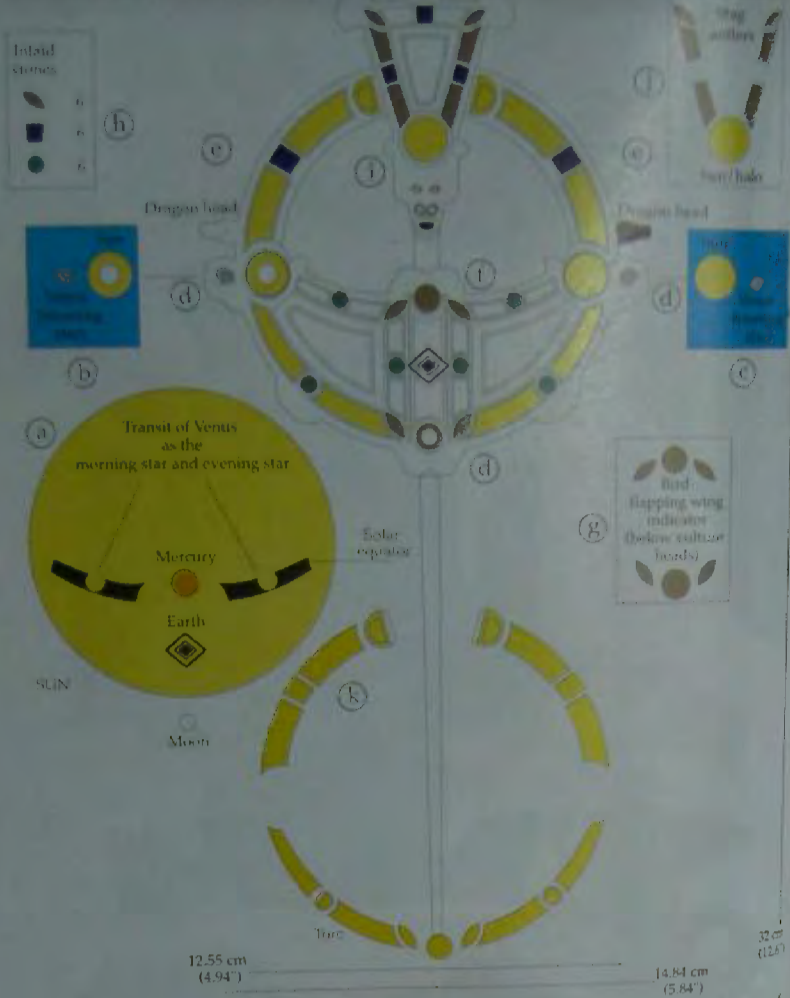

Plate 22. The Tara brooch contains the super-science of the Sun and the higher orders of spirituality. (a) The main ring represents the disc of the Sun. The planet Mercury appears closest to the Sun. The twin-star (planet) Venus is seen in both of its manifestations (as the morning star and the evening star) transiting the face of the Sun along the solar equator [also shown in (b) and (c)]. The Earth, represented by the square [in China, by the square in Venus, and the moon is shown in its orbit around the Earth. (d) Bird/dragon heads (also shown in plate 21a and 21j). (e) Dragon head astronomical data indicators (also shown in plate 21a and 21f). (f) and (g) Flapping wing vulture indicators. (h) The number 666 represented by inlaid stones. (i and j) The stag [the mark of Cernunnos—Christ] (figure 22) wearing a halo and antlers [containing the number 144,000 (plate 20c)]. (k) Torc of Cernunnos [Venus] (figure 22).

The Ardagh Chalice—the Holy Grail



Plate 23. (a) The so-called 'Ardagh Chalice', a solar cross features in between the handles on both sides of the bowl. A ring of 12 enamelled studs, inlaid with bronze and silver wire—to produce twelve individual patterns—circumscribes the cup beneath the rim. The name of an Apostle is engraved beneath each of the studs. The ones seen here, box-framed) read IACOBI [James] and TATHEVS [Thaddeus [Jude Thaddeus]].

The Secrets of Tara Brooch (III)

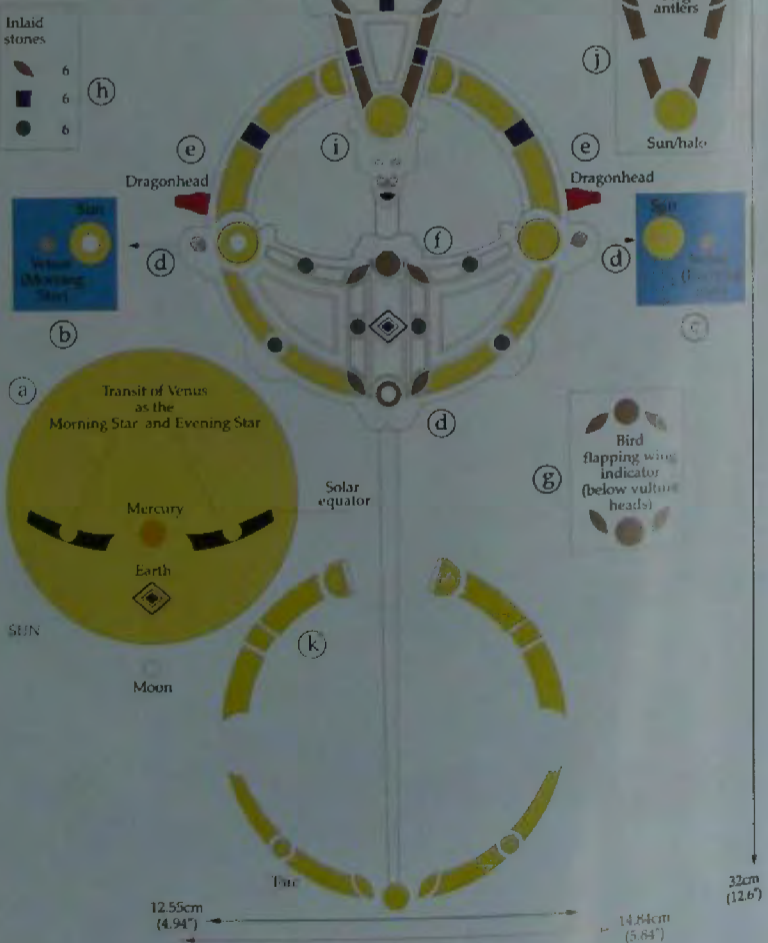

Plate 22. The Tara Brooch contains the super-science of the Sun and the higher orders of spirituality; (a) The main ring represents the disc of the Sun. The planet Mercury appears closest to the Sun. The twin-star (planet) Venus is seen in both of its manifestations (as the morning star and the evening star) transiting the face of the Sun along the solar equator [also shown in (b) and (c)]. The Earth, represented by the square [in China, by the square in Venus, and the moon is shown in its orbit around the Earth. (d) Bird/dragon heads (also shown in plate 21a and 21j). (e) Dragon head astronomical data indicators (also shown in plate 21a and 21f). (f) and (g) Flapping wing vulture indicators. (h) The number 666 represented by inlaid stones. (i and j) The stag [the mark of Cernunnos—Christ] (figure 22) wearing a halo and antlers [containing the number 144,000 (plate 20c)]. (k) Torc of Cernunnos [Venus] (figure 22).

The Ardagh Chalice—the Holy Grail

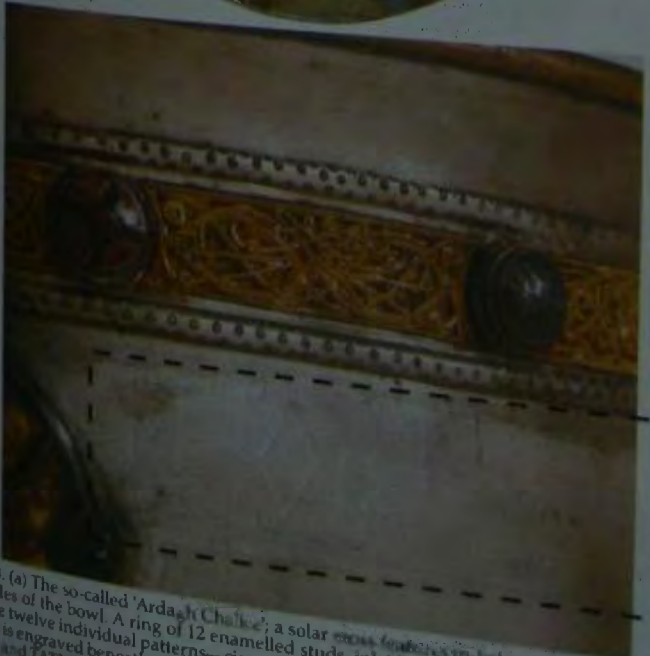

Plate 23. (a) The so-called 'Ardagh Chalice', a solar cross features in between the handles on both sides of the bowl. A ring of 12 enamelled studs, inlaid with bronze and silver wire—to produce twelve individual patterns—circumscribes the cup beneath the rim. The name of an Apostle is engraved beneath each of the studs. The ones seen here, box-framed) read IACOBI [James] and TATHEVS [Thaddeus [Jude Thaddeus]].

The Secrets of Tara Brooch (III)



Plate 22. The Tara brooch contains the super-science of the Sun and the higher orders of spirituality. (a) The main ring represents the disc of the Sun. The planet Mercury appears closest to the Sun. The twin-star (planet) Venus is seen in both of its manifestations (as the morning star and the evening star) transiting the face of the Sun along the solar equator [also shown in (b) and (c)]. The Earth, represented by the square [in China], is shown beyond Venus and the moon is shown in its orbit around the Earth. (d) Bird/dragon heads (also shown in plate 21i and 21j). (e) Dragon head astronomical data indicators (also shown in plate 21a and 21i). (f) and (g) Flapping wing vulture indicators. (h) The number 666 represented by inlaid stones. (i and j) The stag [the mark of Cernunnos—Christ] (figure 22) wearing a halo and antlers [containing the number 144,000 (plate 20c)]. (k) Torc of Cernunnos [Venus] (figure 22).

Plate 23. (a) The so-called both sides of the bowl. Produce twelve individ Apostle is engraved be LACOM (James) and

The Secrets of Tara Brooch (III)

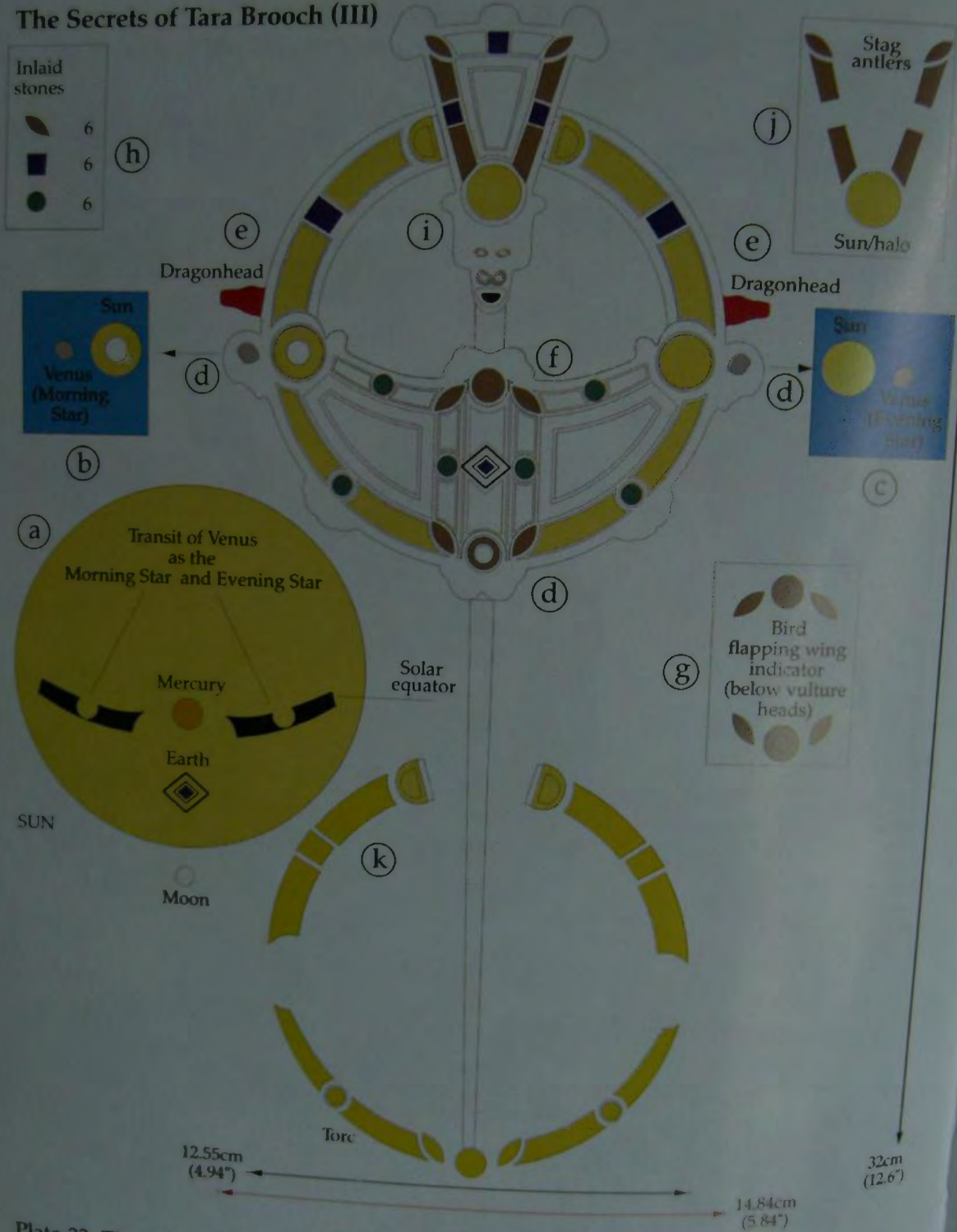

Plate 22. The Tara Brooch contains the super-science of the Sun and the higher orders of spirituality; (a) The main ring represents the disc of the Sun. The planet Mercury appears closest to the Sun. The twin-star (planet) Venus is seen in both of its manifestations (as the morning star and the evening star) transiting the face of the Sun along the solar equator [also shown in (b) and (c)]. The Earth, represented by the square [in China] is shown beyond Venus, and the moon is shown in its orbit around the Earth. (d) Bird/Dragon heads (also shown in plate 21i and 21j). (e) Dragonhead astronomical data indicators (also shown in plate 21a and 21f). (f) and (g) Flapping wing vulture indicators. (h) The number 666 represented by inlaid stones. (i and j) The stag [the mark of Cernunnos—Christ] (figure 22) wearing a halo and antlers [containing the number 144,000 (plate 20c)]. (k) Torc of Cernunnos [Venus] (figure 22).

Plate 23. (a) The both sides of the produce twelve Apostle is engr [James] and TATI

The Ardagh Chalice—
The Holy Grail



(a)



(b)

Plate 23. (a) The so-called 'Ardagh Chalice'; a solar cross features in-between the handles on both sides of the bowl. A ring of 12 enamelled studs, inlaid with bronze and silver wire—to produce twelve individual patterns—circumscribes the cup beneath the rim. The name of an Apostle is engraved beneath each of the studs. The ones seen here, box-framed) read IACOBI [James] and TATHEVS (Thaddeus [Jude Thaddeus]).

32cm
(12.6")

...ders of
...appears
...s (as the
...tor [also
...d Venus,
...shown in
...e 21a and
...by inlaid
...halo and
...gure 22).

The Ardagh Chalice—
the Holy Grail



a



b

Plate 23. (a) The so-called Ardagh Chalice. A solar cross features in between the handles on both sides of the bowl. A ring of 12 enamelled studs, inlaid with bronze and silver wire—to produce twelve individual patterns—circumscribes the cup beneath the rim. The name of an Apostle is engraved beneath each of the studs. (b) The ones seen here (box-framed) read IACOBI [James] and TATHEVS [Thaddeus (Jude Thaddeus)].

The Mosaic Mask of Palenque
The First Picture of God (I)



Plate 24. The mosaic mask of Palenque transparencies, set to 99.9°, reveal a complex picture confirming that Lord Pacal (who made the mask), Viracocha and Christ were all one and the same spiritual energy. (a) The main character is the man with the hat from the tomb of Viracocha Pachacamac [box-framed] in Peru. (b) Viracocha also appears as a crab (purple) across the man's face. The [egg-shaped] face of the bat god [with appendages on the forehead] in turn covers the face of the crab (hence the three sets of eyes). The soul of the man can be seen in the centre of his hat emerging from a hole in his head (see also plate 21g). (c) The soul is caught in the open beak of an eagle who carries it away to the heavens. (d) Just beneath the soul a Christlike figure stands, emulating the Crucifixion, carrying the compasses of the Freemason in his hands (his face and ankles are coloured red to help identification). The eagle carries away the compasses and the Christlike figure in its claws. The man with the hat takes flight as his spirit flies away (see also figures 65 and 66).

At around the same time, Arthur's evil stepsister Morgan-le-Fay seduces Arthur, using sorcery and trickery partially learned from Merlin, and becomes pregnant, in the hope of prising the crown from Arthur's lineage to her own.

Without Excalibur the land falls into decline and Arthur, depressed, sends his knights on a quest for the Holy Grail in the hope that the powers of the Grail will compensate for the loss of the sword. All of the knights search for the Grail without success and find only death. In Malory's version the knight Perceval sees the Grail but is unable to retrieve it. Following Perceval's attempt one seat is left empty at the round table, the Siege Perilous [the seat of peril]. Merlin ordains:

... in the Siege Perilous there shall no man sit therein but one, and if there be any so hardy to do it he shall be destroyed, and he that shall sit there shall have no peril.

As we have already heard, another version says that the Grail passed in a line of stewardship from Joseph of Arimathea eventually to the knight Sir Galahad who 'took our Lord's body between his hands more than 300 years after Joseph's death'.

Arthur, worn out and weary from a broken heart after years away from his beloved Guinevere, forgives her in his heart and mind. She then meets with Arthur and returns Excalibur, which she has treasured and kept safe during their years apart.

During the years of the quest Arthur's son by Morgan-le-Fay, Mordred, grows to manhood and challenges Arthur to hand over the crown. Refusing, the two armies go into battle on Salisbury Plain where both Arthur and Mordred are mortally wounded. Two surviving knights, Lucan and Bedivere, help Arthur to a chapel by the sea. Arthur asks that Excalibur be tossed into a lake, saying, 'one day a king will come and raise the sword again'. Arthur's body is then carried to his final resting place in Glastonbury where the inscription on his tomb reads 'here lies Arthur king that was, king that shall be', referring to the fact that he would be born again: a king in Heaven.

Like Chrétien's account of the Arthurian legends (*Perceval ou le conte du Graal*), Malory's version must surely be allegorical allowing us, once again, to reconsider the quotation from Rabbi Moses Maimonides:

The Mosaic Mask of Palenque
The first Picture of God (I)



Plate 24. The Mosaic Mask of Palenque transparencies, set to 99.9°, reveal a complex picture confirming that Lord Pacal (who made the mask), Viracocha and Christ were all one and the same spiritual energy. (a) The main character is the man with the hat from the tomb of Viracocha Pachacamac [box-framed] in Peru. (b) Viracocha also appears as a crab (purple) across the man's face. The [egg-shaped] face of the bat god [with appendages on the forehead] in turn covers the face of the crab (hence the three sets of eyes). The soul of the man can be seen in the centre of his hat emerging from a hole in his head (see also plate 21g). (c) The soul is caught in the open beak of an eagle who carries it away to the heavens. (d) Just beneath the soul a Christlike figure stands, emulating the Crucifixion, carrying the compasses of the Freemason in his hands (his face and ankles are coloured red to help identification). The eagle carries away the compasses and the Christlike figure in its claws. The man with the hat takes flight as his spirit flies away (see also figures 64 and 65).

Encoding of Celtic Numbers

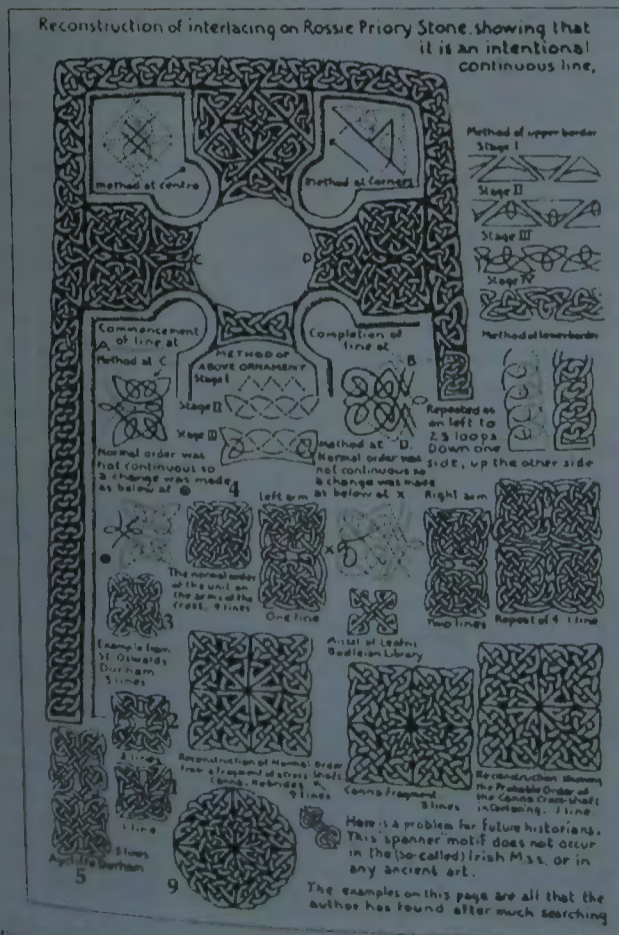

Figure 37. George Bain's observations showed that Celtic continuous-line interlacing patterns comprise of either 1-, 2-, 3-, 4-, 5- or 9-line construction. No 6-line pattern has been found. Celtic pattern numbers thus stop at 6, except for the 8-line pattern, the Sun, drawing attention to the significance of the numbers 6 and 9 (666 and 999) and the Sun, showing once again that the Celts were aware of the deeper science of the Sun and the higher orders of spirituality. (From *The Celtic Art - Methods of Construction*)

The Mosaic Mask of Palenque The First Picture of God (II)



Plate 24. The mosaic mask of Palenque transparencies, set to 99.9°, reveal a complex picture confirming that Lord Pacal (who made the mask), Viracocha and Christ were all one and the same spiritual energy. (a) The main character is the man with the hat from the tomb of Viracocha Pachacamac [box-framed] in Peru. (b) Viracocha also appears as a crab (purple) across the man's face. The [egg-shaped] face of the bat god [with appendages on the forehead] in turn covers the face of the crab (hence the three sets of eyes). The soul of the man can be seen in the centre of his hat emerging from a hole in his head (see also plate 21g). (c) The soul is caught in the open beak of an eagle who carries it away to the heavens. (d) Just beneath the soul a Christlike figure stands, emulating the Crucifixion, carrying the compasses of the Freemason in his hands (his face and ankles are coloured red to help identification). The eagle carries away the compasses and the Christlike figure in its claws. The man with the hat takes flight as his spirit flies away (see also figures 65 and 66).

The Mosaic Mask of Palenque
The First Picture of God III



Plate 24. The mosaic mask of Palenque transparencies, set to 99.9°, reveal a complex picture confirming that Lord Pacal (who made the mask), Viracocha and Christ were all one and the same spiritual energy. (a) The main character is the man with the hat from the tomb of Viracocha Pachacamac [box-framed] in Peru. (b) Viracocha also appears as a crab (purple) across the man's face. The [egg-shaped] face of the bat god [with appendages on the forehead] in turn covers the face of the crab (hence the three sets of eyes). The soul of the man can be seen in the centre of his hat emerging from a hole in his head (see also plate 21g). (c) The soul is caught in the open beak of an eagle who carries it away to the heavens. (d) Just beneath the soul a Christlike figure stands, emulating the Crucifixion, carrying the compasses of the Freemason in his hands (his face and ankles are coloured red to help identification). The eagle carries away the compasses and the Christlike figure in its claws. The man with the hat takes flight as his spirit flies away (see also figures 65 and 66).

At around the same time, Arthur's evil stepsister Morgan-le-Fay seduces Arthur, using sorcery and trickery partially learned from Merlin, and becomes pregnant, in the hope of prising the crown from Arthur's lineage to her own.

Without Excalibur the land falls into decline and Arthur, depressed, sends his knights on a quest for the Holy Grail in the hope that the powers of the Grail will compensate for the loss of the sword. All of the knights search for the Grail without success and find only death. In Malory's version the knight Perceval sees the Grail but is unable to retrieve it. Following Perceval's attempt one seat is left empty at the round table, the Siege Perilous [*the seat of peril*]. Merlin ordains:

... in the Siege Perilous there shall no man sit therein but one, and if there be any so hardy to do it he shall be destroyed, and he that shall sit there shall have no peril.

As we have already heard, another version says that the Grail passed in a line of stewardship from Joseph of Arimathea eventually to the knight Sir Galahad who 'took our Lord's body between his hands more than 300 years after Joseph's death'.

Arthur, worn out and weary from a broken heart after years away from his beloved Guinevere, forgives her in his heart and mind. She then meets with Arthur and returns Excalibur, which she has treasured and kept safe during their years apart.

During the years of the quest Arthur's son by Morgan-le-Fay, Mordred, grows to manhood and challenges Arthur to hand over the crown. Refusing, the two armies go into battle on Salisbury Plain where both Arthur and Mordred are mortally wounded. Two surviving knights, Lucan and Bedivere, help Arthur to a chapel by the sea. Arthur asks that Excalibur be tossed into a lake, saying, 'one day a king will come and raise the sword again'. Arthur's body is then carried to his final resting place in Glastonbury where the inscription on his tomb reads 'here lies Arthur king that was, king that shall be', referring to the fact that he would be born again: a king in Heaven.

Like Chrétien's account of the Arthurian legends (*Perceval ou le conte du Graal*), Malory's version must surely be allegorical allowing us, once again, to reconsider the quotation from Rabbi Moses Maimonides:

119

THE CYCLES

after Uther is mortally wounded in battle and as he dies he thrust his sword Excalibur into a large boulder in the forest saying 'he who draws the sword from the stone shall be [the next] King'.

Merlin passes Arthur to the noble family of Sir Ector who foster and rear the child as one of their own, for around 18 years.

After Uther's death England had no King and Nobleman of the times met regularly in jousting tournaments to decide who should have the title. Merlin reminds them that only 'he who draws the sword from the stone' shall be eligible to become King. Many knights try to draw the sword from the stone but all fail. Some years later Arthur journeyed to London to watch a tournament in which his guardian knight was taking part. Realising he had mislaid his sword the knight instructed Arthur to find one, whereupon Arthur effortlessly 'pulled the sword from the stone' to become King of England and, using the powers of Excalibur, the greatest warrior-king in the land.

One day Lancelot 'the bravest knight from a land overseas' meets Arthur on a bridge that covers a stream and challenges his right to be King. A sword-fight breaks out during which Lancelot questions Arthur's irrational passion saying 'who are you Sir, who will fight to the death for a stretch of road you could easily ride around?'

Using the powers of Excalibur Arthur wins the fight but accidentally breaks the magic sword into two, effectively breaking that which legend says 'could not be broken'. Arthur, filled with remorse, recognises that the sword has been taken from him because of his own ego, pride and anger. He had misused the powers of the sword on a good man. Falling to the ground, he begs God for forgiveness and apologises to Lancelot. Merlin appears and summons a new sword from the lake and Lancelot pledges allegiance to Arthur.

This is the heyday of Arthurian rule. He marries Guinevere, the daughter of the Knight Leon de Grance and establishes a 'Round Table' of sun worship at his magnificent mediaeval castle in Camelot where fellow knights, inspired by courage, truth, duty and sacrifice meet to enjoy the days of peace and tranquillity.

There is no consensus for the number of knights who joined Arthur at his Round Table. Malory's version gives 26, representing the 26-day rotation rate of the Sun's equatorial magnetic field. In other versions (plates

A LAND WITHOUT A KING

17 and 19) 9 knights are proposed, the highest number that can be reached before becoming one with God.

All is well at the Round Table until Lancelot meets Guinevere. The couple fall in love and betray Arthur. Arthur, devastated, discovers them, entwined. Unable to forgive them, he thrusts Excalibur into the ground next to their naked bodies, thus banishing them both from the land.

At around the same time Arthur's evil stepsister Morgan-le-Fay seduces Arthur, using sorcery and trickery partially learned from Merlin, and becomes pregnant, in the hope of prising the crown from Arthur's lineage to her own.

Without Excalibur the land falls into decline and Arthur, depressed, sends his knights on a quest for the Holy Grail in the hope that the powers of the Grail will compensate for the loss of the sword. All of the knights search for the Grail without success and find only death. In Malory's version the knight Perceval sees the Grail but is unable to retrieve it. Following Perceval's attempt one seat is left empty at the round table, the Siege Perilous [*the seat of peril*]. Merlin ordains:

... in the Siege Perilous there shall no man sit therein but one, and if there be any so hardy to do it he shall be destroyed, and he that shall sit there shall have no peril.

As we have already heard, another version says that the Grail passed in a line of stewardship from Joseph of Aramathea eventually to the knight Sir Galahad who 'took our Lord's body between his hands more than 300 years after Joseph's death'.

Arthur, worn out and weary from a broken heart after years away from his beloved Guinevere, forgives her in his heart and mind. She then meets with Arthur and returns Excalibur, which she has treasured and kept safe during their years apart.

During the years of the quest Arthur's son by Morgan-le-Fay, Mordred, grows to manhood and challenges Arthur to hand over the Crown. Refusing, the two armies go into battle on Salsbury Plain where both Arthur and Mordred are mortally wounded. Two surviving knights, Lucan and Bedivere, help Arthur to a chapel by the sea. Arthur asks that Excalibur be tossed into a lake, saying, 'one day a king will come and raise the sword again'. Arthur's body is then carried to his final resting place in

King Arthur (Lineage)

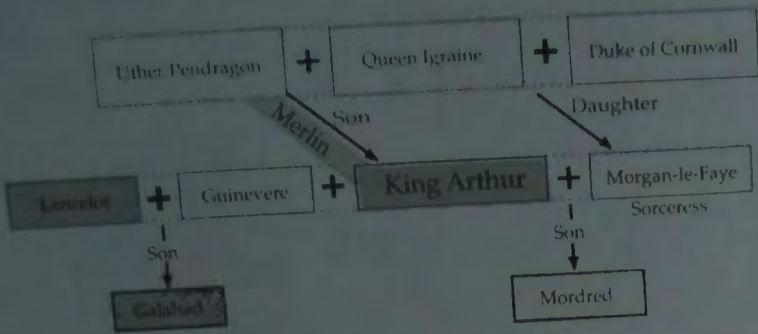

Figure 40. Lineage of King Arthur and his associates. Merlin, the magician, was the mentor of King Uther who summoned the magical sword Excalibur to help Uther win battles and become king. Using trickery and deception he arranged the union between Uther and Igraine that resulted in the birth of Arthur. After Uther's death Merlin counsels Arthur as king.

The Knights of the Round Table

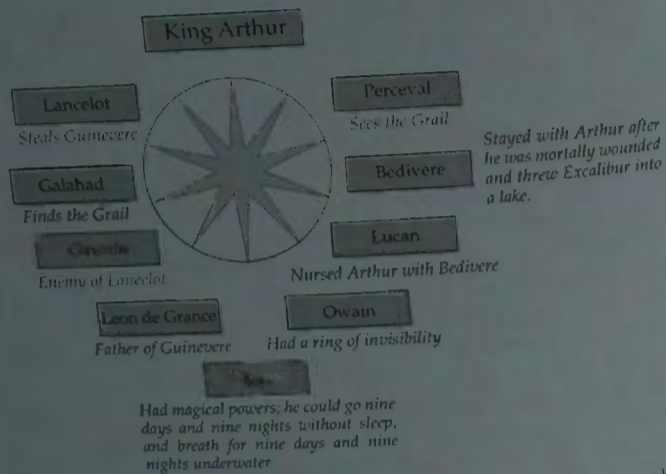

Figure 41. Arthur established the Round Table in thanks to God for giving the land one king, peace and prosperity. The warrior-knights were a brethren of Freemasons who met regularly to discuss the secrets of the Sun and the higher orders of spirituality. These names feature in Malory's version of the Arthurian legend but other accounts include other knights.

Every time you find in . . . a tale, the reality of which is repugnant to both reason and common sense, then be sure that the tale contains a profound allegory veiling a deeply mysterious truth; and the greater the absurdity of the letter, the deeper the wisdom of spirit. (*Hidden Wisdom in the Holy Bible*, vol. 1, G. Hodson, Wheaton, Ill.: Theosophical Publishing House)

Malory was trying to convey that Excalibur, the magical double-edged sword of truth and courage, was the only thing that could bring peace to the land—meaning, more specifically, that only truth and courage will bring peace. Lord Krishna gives the same message to the soldier Arjuna in the Bhagavad Gita before the battle of Kurukshetra begins. During the discourse Lord Krishna tells Arjuna that the battle should be fought not because it might be won or lost but out of duty, because it needs to be fought. If he wins, he will become a king on Earth and should he lose he will become a king in Heaven, because he has performed his duty.

The Bhagavad Gita then considers the nature of attachment:

In this world there is a two-fold path. There is the path of wisdom for those who meditate and the path of action for those who work. No man can refrain from activity by refraining from action; nor can he reach perfection by refusing to act. He cannot remain inactive because Nature will compel him to act or not to act. All honour to him whose mind controls his senses; because he is thereby beginning to practise 'karma-yoga', the path of right action, keeping himself always unattached. Do your duty as prescribed; for action for duty's sake is superior to inaction . . . let your acts be done without attachment, as sacrifice only . . . he who does not help the revolving wheel of sacrifice but instead leads a sinful life, rejoicing in the gratification of his senses, O Arjuna! He breathes in vain. (*The Bhagavad Gita*, chapter III, Shri Purohit Swami, Faber & Faber, 1935)

And in regard to desire:

Desire leads to frustration, frustration to anger, anger to delusion and delusion to self-destruction. (*The Bhagavad Gita*, chapter II, Shri Purohit Swami, Faber & Faber, 1935)

King Arthur (Lineage)

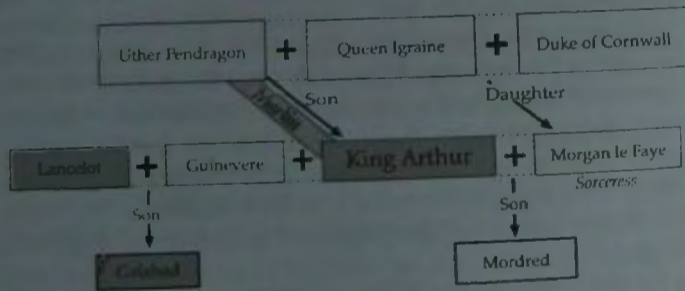

Figure 40. Lineage of King Arthur and his associates. Merlin, the magician, was the mentor of King Uther who summoned the magical sword Excalibur to help Uther win battles and become king. Using trickery and deception he arranged the union between Uther and Igraine that resulted in the birth of Arthur. After Uther's death Merlin counsels Arthur as King.

The Knights of the Round Table

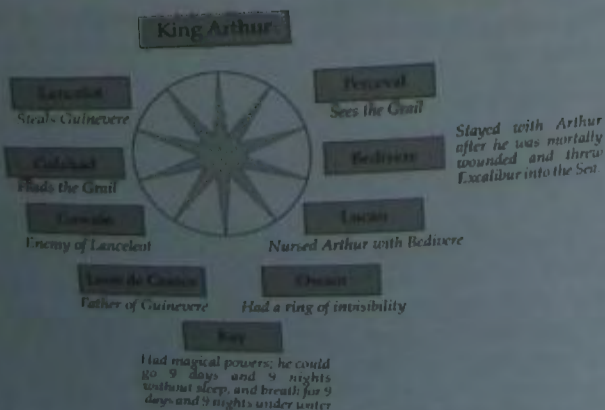

Figure 41. Arthur established the Round Table in thanks to God for giving the land one king, peace and prosperity. The warrior-knights were a brethren of Freemasons who met regularly to discuss the secrets of the Sun and the higher orders of spirituality. These names feature in Malory's version of the Arthurian legend but other accounts include other knights.

Glastonbury where the inscription on his tomb reads 'here lies Arthur King that was, King that shall be', referring to the fact that he would be born again; a King in Heaven.

Like Chrétien de Troyes account of the Arthurian legends (*Perceval ou le conte du Graal*) Malory's version must surely be allegorical allowing us, once again, to reconsider the quotation from Rabbi Moses Maimonides:

Every time you find in . . . a tale, the reality of which is repugnant to both reason and common sense, then be sure that the tale contains a profound allegory veiling a deeply mysterious truth; and the greater the absurdity of the letter, the deeper the wisdom of spirit (*Hidden Wisdom in the Holy Bible*, vol.1, G.Hodson, Wheaton Ill. Theosophical Publishing House).

Malory was trying to convey that Excalibur—the magical double-edged sword of truth and courage—was the only thing that could bring peace to the land; meaning, more specifically, that only truth and courage will bring peace. Lord Krishna gives the same message to the soldier Arjuna in the Bhagava Gita before the battle of Kurukshetra begins. During the discourse Lord Krishna tells Arjuna that the battle should be fought not because it might be won or lost but out of duty, because it needs to be fought. If he wins he will become a King on Earth and should he lose he will become a King in Heaven, because he has performed his duty.

The Bhagavad Gita then considers the nature of attachment:

In this world there is a two-fold path. There is the path of wisdom for those who meditate and the path of action for those who work. No man can refrain from activity by refraining from action; nor can he reach perfection by refusing to act. He cannot remain inactive because Nature will compel him to act or not to act. All honour to him whose mind controls his senses; because he is thereby beginning to practise 'karma-yoga', the path of right action, keeping himself always unattached. Do your duty as prescribed; for action for duty's sake is superior to inaction . . . let your acts be done without attachment, as sacrifice only . . . he who does not help the revolving wheel of sacrifice but instead leads a sinful life, rejoicing in the gratification of his senses, O Arjuna! He breathes in vain. (*The Bhagavad Gita*, Chapter III, Shri Purohit Swami, Faber & Faber, 1935).

King Arthur had broken the sword in a fit of vanity, ego and rage fighting a pointless battle with Lancelot who questioned what the fight was about: 'you will fight to the death for a piece of road that you could easily ride around'. Arthur repents and asks for forgiveness and in return Merlin summons a replacement sword. This part of the tale reassures us that if we repent, we will be restored to our previous position.

But, in time, his desires fulfilled, Arthur forgets about the importance of the sword (truth and courage) and, sliding into a life of ease, comfort, inaction and attachment, relegates the importance of the sword to second place in his life, preferring instead the affections of Guinevere. She is thus taken away from him, into the arms of Lancelot who might more deserve her affections because he lacks the ego, vanity and passion earlier displayed by Arthur. Again driven by ego and anger Arthur, unable to forgive, thrusts Excalibur into the ground alongside the sleeping lovers as an expression of dismay. His land, his alliance with the Knights of the Round Table and his health now all begin to slip into oblivion, until he finds it in his heart to forgive Guinevere and Lancelot. He searches for Christ (the blood of Christ in the Grail). Finding the Grail, he finds it in his heart to forgive Guinevere and Lancelot. Then Excalibur, truth and courage, return to him. Finally, he falls, to rise again a king in Heaven.

Therein lies the allegory in the tale. But how could the allegory be saved, written down and preserved for future generations to help those on the narrow path to get to Heaven next time around? As before, it could be set down in pictures or numbers as well as myth.

The Pre-Raphaelites

The pharaohs of the Old Kingdom were the first in our present cosmic cycle to encode the secret teachings into the pyramids. Tutankhamun, Solomon, Ch'in Shi Huangdi, the Viracochas and Lord Pacal continued the tradition in their own times. During the Middle Ages mediaeval Freemasons encoded the knowledge into the architecture of the cathedrals that blossomed throughout Europe. And then, the Pre-Raphaelite artists, a body of Freemasons known as the Brotherhood, continued the ancient tradition encoding the secrets for themselves, in paintings, tapestries and stained glass as their forefathers had done before them.

122

William Morris, one of the great Pre-Raphaelites, was born in 1834, the son of a wealthy copper-mining industrialist in Victorian England. In 1853 he moved to Oxford to study theology at the University but soon switched to architecture. There, he befriended Edward Burne-Jones, who became one of the most famous Pre-Raphaelites. In 1853 the two teamed up with the painter Dante Gabriel Rossetti and the colloquial 'Brotherhood' was born. John Everett Millais, John W. Waterhouse, Arthur Hughes, Ford Maddox-Brown, William Holman Hunt, Edmund Blair, Leighton Frank Dicksee, William Frank Calderon and others soon joined them.

As before, their aim was to sing the praise of God in their works, believing that the soul of man could be raised to Heaven through artistic expression. They longed for a bygone romantic age—the age of chivalry, courage, duty and truth enshrined in the Arthurian legends.

One of the first collaborative projects undertaken by Morris, Burne-Jones and Rossetti was the painting of the ceiling of the Oxford University Union building with water-colour frescoes of the much loved Arthurian legends. One of the last, by Burne-Jones and Morris, was the design and production of a series of six 'Holy Grail' tapestry panels that had been commissioned by an Australian mining engineer, William Knox D'Arcy, to decorate the walls of Stanmore Hall. The series consisted of: 1. The Knights of the Round Table Summoned to the Quest by a Damsel (plate 17); 2. The Arming and Departure of the Knights; 3. The Failure of Sir Lancelot to enter the Chapel of the Holy Grail; 4. The Failure of Sir Gawaine; 5. The Ship; and 6. The Attainment.

It took Burne-Jones three years to finish the design of the scenes that he started in 1890. Morris, who by that time had become the foremost designer and producer of tapestries, wallpaper, stained glass and furniture in England, then wove the tapestries. The six magnificent tapestries featuring the Arthurian legends are now kept in the Birmingham Museum and Art Gallery in England. Another complete set was woven for William D'Arcy's partner, Mr. McCulloch, for his house in Queen's Gate, London, and a handful of individual panel repeats were produced for other clients.

The fact that they referred to themselves as the Brotherhood implies that they must have inherited their esoteric knowledge from their Freemason fathers. Plate 18, *Fair Rosamund*, by John W. Waterhouse

123

THE CELTIC CHRONICLES

And in regard to desire;

Desire leads to frustration, frustration to anger, anger to delusion and delusion to self-destruction (*The Bhagavad Gita*, Chapter II, Shri Purohit Swami, Faber & Faber, 1935).

King Arthur had broken the sword in a fit of vanity, ego and rage fighting a pointless battle with Lancelot who questioned what the fight was about: 'you will fight to the death for a piece of road that you could easily ride around'. Arthur repents and asks for forgiveness and in return Merlin summons a replacement sword. This part of the tale reassures us that if we repent we will be restored to our previous position.

But, in time, his desires fulfilled, Arthur forgets about the importance of the sword (truth and courage) and, sliding into a life of ease, comfort, inaction and attachment relegates the importance of the sword to second place in his life, preferring instead the affections of Guinevere. She is thus taken away from him, into the arms of Lancelot who might more deserve her affections because he lacks the ego, vanity and passion earlier displayed by Arthur. Again driven by ego and anger Arthur, unable to forgive, thrusts Excalibur into the ground alongside the sleeping lovers as an expression of dismay. His land, his alliance with the Knights of the Round Table and his health now all begin to slip into oblivion, until he finds it in his heart to forgive Guinevere and Lancelot. He searches for Christ (the blood of Christ in the Grail). Finding the Grail he finds it in his heart to forgive Guinevere and Lancelot. Then Excalibur, truth and courage, return to him. Finally, he falls, to rise again a King in Heaven.

Therein lies the allegory in the tale. But how could the allegory be saved, written down and preserved for future generations to help those on the narrow path to get to Heaven next time around? As before, it could be set down in pictures or numbers as well as myth.

The Pre-Raphaelites

The Pharaohs of the Old Kingdom were the first in our present cosmic cycle to encode the secret teachings into the pyramids. Tutankhamun, Solomon, Ch'in Shi Huangdi, the Viracochas and Lord Pacal continued the tradition in their own times. During the Middle Ages mediaeval Freemasons encoded the knowledge into the architecture of the cathedrals that blossomed throughout Europe. And then, the Pre-Raphaelite artists, a body of Freemasons known as the Brotherhood, continued the ancient tradition encoding the secrets for themselves, in paintings, tapestries and stained glass as their forefathers had done before them.

124

A LAND WITHOUT A KING

And then, the Pre-Raphaelite artists, a body of Freemasons known as 'the brotherhood', continued the ancient tradition encoding the secrets for themselves, in paintings, tapestries and stained glass as their forefathers had done before them.

William Morris, one of the great Pre-Raphaelites, was born in 1834, the son of a wealthy Copper mining industrialist in Victorian England. In 1853 he moved to Oxford, to study theology at the University but soon switched to Architecture. There, he befriended Edward Burne-Jones who became one of the most famous Pre-Raphaelites. In 1853 the two teamed up with the painter Dante Gabriel Rossetti and the colloquial 'Brotherhood' was born. John Everett Millais, John W. Waterhouse, Arthur Hughes, Ford Maddox-Brown, William Holman Hunt, Edmund Blair, Leighton Frank Dicksee, William Frank Calderon and others soon joined them.

As before, their aim was to sing the praise of God in their works, believing that the soul of man could be raised to Heaven through artistic expression. They longed for a bygone romantic age—the age of chivalry, courage, duty and truth enshrined in the Arthurian legends.

One of the first collaborative projects undertaken by Morris, Burne-Jones and Rossetti was the painting of the ceiling of the Oxford University Union building with water-colour frescoes of the much loved Arthurian legends. One of the last, by Burne-Jones and Morris, was the design and production of a series of six 'Holy Grail' tapestry panels that had been commissioned by an Australian mining Engineer, William Knox D'Arcy, to decorate the walls of Stanmore Hall. The series comprised of: 1. The Knights of the Round Table Summoned to the Quest by a Damsel (plate 17). 2. The Arming and Departure of the Knights. 3. The Failure by Sir Lancelot to enter the Chapel of the Holy Grail. 4. The Failure of Sir Gawaine. 5. The Ship and 6. The Attainment.

It took Burne-Jones three years to finish the design of the scenes that he started in 1890. Morris, who by that time had become the foremost designer and producer of tapestries, wallpaper, stained glass and furniture in England, then wove the tapestries. The six magnificent tapestries featuring the Arthurian legends are now kept in the Birmingham Museum and Art Gallery in England. Another complete set was woven for William D'Arcy's partner, Mr McCulloch, for his house in Queen's Gate,

King Arthur had broken the sword in a fit of vanity, ego and rage fighting a pointless battle with Lancelot who questioned what the fight was about: 'you will fight to the death for a piece of road that you could easily ride around'. Arthur repents and asks for forgiveness and in return Merlin summons a replacement sword. This part of the tale reassures us that if we repent, we will be restored to our previous position.

But, in time, his desires fulfilled, Arthur forgets about the importance of the sword (truth and courage) and, sliding into a life of ease, comfort, inaction and attachment, relegates the importance of the sword to second place in his life, preferring instead the affections of Guinevere. She is thus taken away from him, into the arms of Lancelot who might more deserve her affections because he lacks the ego, vanity and passion earlier displayed by Arthur. Again driven by ego and anger Arthur, unable to forgive, thrusts Excalibur into the ground alongside the sleeping lovers as an expression of dismay. His land, his alliance with the Knights of the Round Table and his health now all begin to slip into oblivion, until he finds it in his heart to forgive Guinevere and Lancelot. He searches for Christ (the blood of Christ in the Grail). Finding the Grail, he finds it in his heart to forgive Guinevere and Lancelot. Then Excalibur, truth and courage, return to him. Finally, he falls, to rise again a king in Heaven.

Therein lies the allegory in the tale. But how could the allegory be saved, written down and preserved for future generations to help those on the narrow path to get to Heaven next time around? As before, it could be set down in pictures or numbers as well as myth.

The Pre-Raphaelites

The pharaohs of the Old Kingdom were the first in our present cosmic cycle to encode the secret teachings into the pyramids. Tutankhamun, Solomon, Ch'in Shi Huangdi, the Viracochas and Lord Pacal continued the tradition in their own times. During the Middle Ages mediaeval Freemasons encoded the knowledge into the architecture of the cathedrals that blossomed throughout Europe. And then, the Pre-Raphaelite artists, a body of Freemasons known as the Brotherhood, continued the ancient tradition encoding the secrets for themselves, in paintings, tapestries and stained glass as their forefathers had done before them.

122

THE CELTIC CHRONICLES

And in regard to desire:

Desire leads to frustration, frustration to anger, anger to delusion and delusion to self-destruction (*The Bhagavad Gita, Chapter II, Sri Parashra Swami, Faber & Faber, 1935*)

King Arthur had broken the sword in a fit of vanity, ego and rage fighting a pointless battle with Lancelot who questioned what the fight was about: 'you will fight to the death for a piece of road that you could easily ride around'. Arthur repents and asks for forgiveness and in return Merlin summons a replacement sword. This part of the tale reassures us that if we repent we will be restored to our previous position.

But, in time, his desires fulfilled, Arthur forgets about the importance of the sword (truth and courage) and, sliding into a life of ease, comfort, inaction and attachment relegates the importance of the sword to second place in his life, preferring instead the affections of Guinevere. She is thus taken away from him, into the arms of Lancelot who might more deserve her affections because he lacks the ego, vanity and passion earlier displayed by Arthur. Again driven by ego and anger Arthur, unable to forgive, thrusts Excalibur into the ground alongside the sleeping lovers as an expression of dismay. His land, his alliance with the Knights of the Round Table and his health now all begin to slip into oblivion, until he finds it in his heart to forgive Guinevere and Lancelot. He searches for Christ (the blood of Christ in the Grail). Finding the Grail he finds it in his heart to forgive Guinevere and Lancelot. Then Excalibur, truth and courage, return to him. Finally, he falls, to rise again a King in Heaven.

Therein lies the allegory in the tale. But how could the allegory be saved, written down and preserved for future generations to help those on the narrow path to get to Heaven next time around? As before, it could be set down in pictures or numbers as well as myths.

The Pre-Raphaelites

The Pharaohs of the Old Kingdom were the first in our present cosmic cycle to encode the secret teachings into the pyramids. Tutankhamun, Solomon, Ch'in Shi Huangdi, the Viracochas and Lord Pacal continued the tradition in their own times. During the Middle Ages mediaeval Freemasons encoded the knowledge into the architecture of the cathedrals that blossomed throughout Europe. And then, the Pre-Raphaelite artists, a body of Freemasons known as the Brotherhood, continued the ancient tradition encoding the secrets for themselves, in paintings, tapestries and stained glass as their forefathers had done before them.

123

William Morris, one of the great Pre-Raphaelites, was born in 1834, the son of a wealthy copper-mining industrialist in Victorian England. In 1853 he moved to Oxford to study theology at the University but soon switched to architecture. There, he befriended Edward Burne-Jones, who became one of the most famous Pre-Raphaelites. In 1853 the two teamed up with the painter Dante Gabriel Rossetti and the colloquial 'Brotherhood' was born. John Everett Millais, John W. Waterhouse, Arthur Hughes, Ford Maddox-Brown, William Holman Hunt, Edmund Blair, Leighton Frank Dicksee, William Frank Calderon and others soon joined them.

As before, their aim was to sing the praise of God in their works, believing that the soul of man could be raised to Heaven through artistic expression. They longed for a bygone romantic age—the age of chivalry, courage, duty and truth enshrined in the Arthurian legends.

One of the first collaborative projects undertaken by Morris, Burne-Jones and Rossetti was the painting of the ceiling of the Oxford University Union building with water-colour frescoes of the much loved Arthurian legends. One of the last, by Burne-Jones and Morris, was the design and production of a series of six 'Holy Grail' tapestry panels that had been commissioned by an Australian mining engineer, William Knox D'Arcy, to decorate the walls of Stanmore Hall. The series consisted of: 1. The Knights of the Round Table Summoned to the Quest by a Damsel; 2. The Arming and Departure of the Knights; 3. The Failure by Sir Lancelot to enter the Chapel of the Holy Grail; 4. The Failure of Sir Gawaine; 5. The Ship; and 6. The Attainment.

It took Burne-Jones three years to finish the design of the scenes that he started in 1890. Morris, who by that time had become the foremost designer and producer of tapestries, wallpaper, stained glass and furniture in England, then wove the tapestries. The six magnificent tapestries featuring the Arthurian legends are now kept in the Birmingham Museum and Art Gallery in England. Another complete set was woven for William D'Arcy's partner, Mr. McCulloch, for his house in Queen's Gate, London, and a handful of individual panel repeats were produced for other clients.

The fact that they referred to themselves as the Brotherhood implies that they must have inherited their esoteric knowledge from their Freemason fathers. Plate 18, *Fair Rosamund*, by John W. Waterhouse

123

chairs that blossomed throughout Europe. And then, the Pre-Raphaelite artists, a body of Freemasons known as 'the brotherhood', continued the ancient tradition encoding the secrets for themselves, in paintings, tapestries and stained glass as their forefathers had done before them.

William Morris, one of the great Pre-Raphaelites, was born in 1834, the son of a wealthy Copper mining industrialist in Victorian England. In 1853 he moved to Oxford, to study theology at the University but soon switched to Architecture. There, he befriended Edward Burne-Jones who became one of the most famous Pre-Raphaelites. In 1853 the two teamed up with the painter Dante Gabriel Rossetti and the colloquial 'Brotherhood' was born. John Everett Millais, John W. Waterhouse, Arthur Hughes, Ford Maddox-Brown, William Holman Hunt, Edmund Blair, Leighton Frank Dicksee, William Frank Calderon and others soon joined them.

As before, their aim was to sing the praise of God in their works, believing that the soul of man could be raised to Heaven through artistic expression. They longed for a bygone romantic age—the age of chivalry, courage, duty and truth enshrined in the Arthurian legends.

One of the first collaborative projects undertaken by Morris, Burne-Jones and Rossetti was the painting of the ceiling of the Oxford University Union building with water-colour frescoes of the much loved Arthurian legends. One of the last, by Burne-Jones and Morris, was the design and production of a series of six 'Holy Grail' tapestry panels that had been commissioned by an Australian mining Engineer, William Knox D'Arcy, to decorate the walls of Stanmore Hall. The series comprised of: 1. The Knights of the Round Table Summoned to the Quest by a Damsel (plate 17); 2. The Arming and Departure of the Knights; 3. The Failure by Sir Lancelot to enter the Chapel of the Holy Grail; 4. The Failure of Sir Gawaine; 5. The Ship and 6. The Attainment.

It took Burne-Jones three years to finish the design of the scenes that he started in 1890. Morris, who by that time had become the foremost designer and producer of tapestries, wallpaper, stained glass and furniture in England, then wove the tapestries. The six magnificent tapestries featuring the Arthurian legends are now kept in the Birmingham Museum and Art Gallery in England. Another complete set was woven for William D'Arcy's partner, Mr. McCulloch, for his house in Queen's Gate,

124

London and a handful of individual panel repeats were produced for other clients.

The fact that they referred to themselves as the Brotherhood infers that they must have inherited their esoteric knowledge from their freemason fathers'. Plate 18, *Fair Rosamund*, by John W. Waterhouse (1916) and its schematic, figure 42, demonstrate how they went about encoding esoteric information into their works: The art lover sees only a good quality picture of a princess anxiously waiting for her knight in shining armour to pass-by. It seems that the chambermaid has been ushered behind the curtain, to take a break from spinning—just in case, if fate dictates, the knight decides to stop at the window and strike up a conversation. After all, he could hardly be frank and honest about his intentions or feelings if he believed that someone might be listening.

The art expert may have more to say. He might begin by explaining the romantic symbolism contained in Pre-Raphaelite paintings: how, in the painting, the rose clinging to the wall by the window symbolises the princess's desire to cling to her prospective lover. He might go on to explain how her right hand anxiously clutches her left wrist, carefully avoiding contact with the red fabric of the vest she wears beneath her dress—a metaphor that says she 'no longer wishes to hold on to her virginity'. Indeed, a closer look at the floor shows the faintest glimpse of red creeping from beneath her dress, symbolic of the blood from her first loving encounter. And the maid looks on, furtively; realising that these may be the final moments of her employment if the desires of her mistress are fulfilled.

The esotericist will labour longer, in the knowledge that only a human-being filled with God could produce such a beautiful piece of art. He would appreciate instinctively that no individual achieves anything. It is the Godly energy within the individual that achieves. A swallow cannot fly through the branches of a tree at 100 miles per hour. It is not the bird that flies. It is not the bird-brain that achieves. It is God within the bird that flies so miraculously. The esotericist understands the true purpose of life, the higher knowledge, the super-science of the Sun and the higher orders of spirituality. He is eager to share his knowledge with the like-minded and at the same time protect it from the profane. He exists in the spiritual dimension above and away from the profane. It is

The Secrets in the Painting

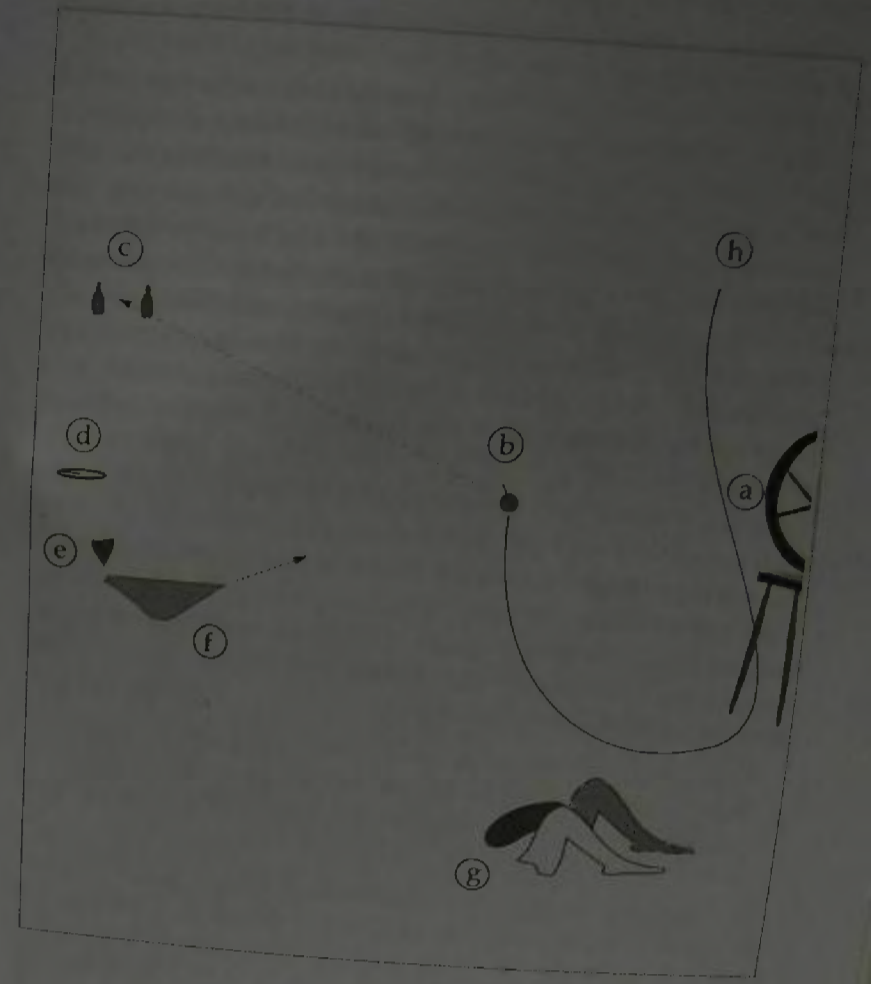

Figure 42. (a) Compasses of the Freemason (set at 66°) representing God, the Great Architect of the Universe. (b) The Sun, on its axis. (c) Twins, representing Venus, the morning star and the evening star. (d) Vagina. (e) Bikini line. (f) Arrow pointing to the vulva of the Princess, the Sun and Heaven. (g) Lovers entwined. (h) Silver thread, the cable-tow. The painting contains a secret story explaining the mysteries of life.

A LAND WITHOUT A KING

(1916) and its schematic, figure 42, demonstrate how they went about encoding esoteric information into their works.

The art lover sees only a good-quality picture of a princess anxiously waiting for her knight in shining armour to pass by. It seems that the chambermaid has been ushered behind the curtain, to take a break from spinning—just in case, if fate dictates, the knight decides to stop at the window and strike up a conversation. After all, he could hardly be frank and honest about his intentions or feelings if he believed that someone might be listening.

The art expert may have more to say. He might begin by explaining the romantic symbolism contained in Pre-Raphaelite paintings: how, in the painting, the rose clinging to the wall by the window symbolises the princess's desire to cling to her prospective lover. He might go on to explain how her right hand anxiously clutches her left wrist, carefully avoiding contact with the red fabric of the vest she wears beneath her dress—a metaphor that says she 'no longer wishes to hold on to her virginity'. Indeed, a closer look at the floor shows the faintest glimpse of red creeping from beneath her dress, symbolic of the blood from her first loving encounter. And the maid looks on, furtively; realising that these may be the final moments of her employment if the desires of her mistress are fulfilled.

The esotericist will labour longer, in the knowledge that only a human being filled with God could produce such a beautiful piece of art. He would appreciate instinctively that no individual achieves anything. It is the godly energy within the individual that achieves. A swallow cannot fly through the branches of a tree at 100 miles per hour. It is not the bird that flies. It is not the bird brain that achieves. It is God within the bird that flies so miraculously. The esotericist understands the true purpose of life, the higher knowledge, the super-science of the Sun and the higher orders of spirituality. He is eager to share his knowledge with the like-minded and at the same time protect it from the profane. He exists in the spiritual dimension above and away from the profane. It is as though the intellectual body hitches itself to the spiritual and in so doing experiences consciousness free of physical or emotional restraint. This capability is not open to lower initiates but only to the higher adepts who have progressed through disciplined study of the sacred sciences, years of devotion and probation.

The Secrets in the Painting

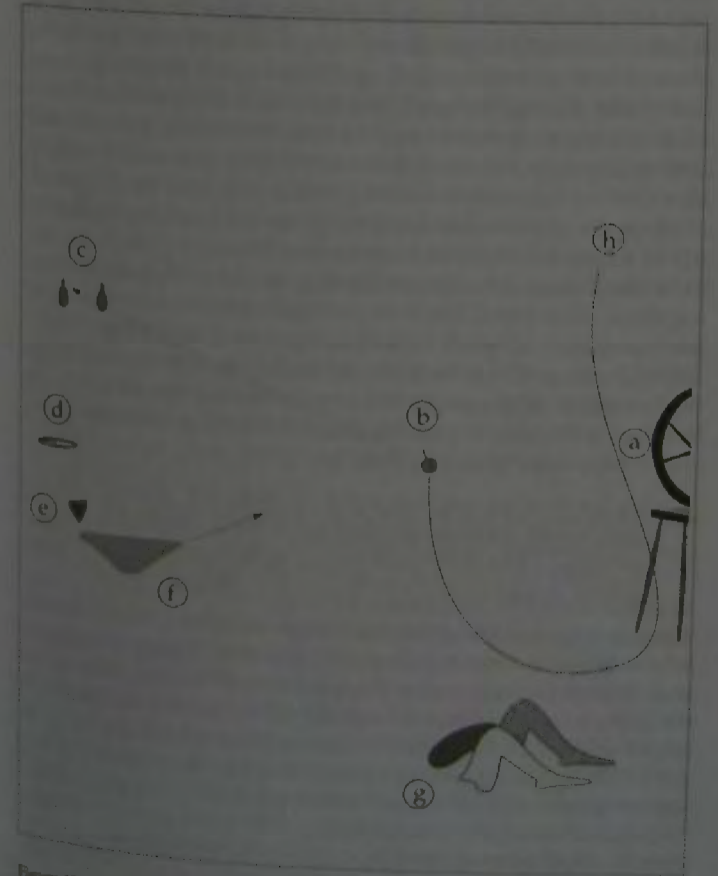

Figure 42. (a) Compasses of the Freemason (set at 66°) representing God, the Great Architect of the Universe. (b) The Sun, on its axis. (c) Twins, representing Venus, the morning star and the evening star. (d) Vagina. (e) Bikini line. (f) Arrow pointing to the vulva of the Princess, the Sun and Heaven. (g) Lovers entwined. (h) Silver thread, the cable-tow. The painting contains a secret story explaining the mysteries of life.

London and a handful of individual panel repeats were produced for other clients.

The fact that they referred to themselves as the Brotherhood infers that they must have inherited their esoteric knowledge from their freemason fathers'. Plate 18, *Fair Rosamund*, by John W. Waterhouse (1916) and its schematic, figure 42, demonstrate how they went about encoding esoteric information into their works. The art lover sees only a good quality picture of a princess anxiously waiting for her knight in shining armour to pass-by. It seems that the chambermaid has been ushered behind the curtain, to take a break from spinning—just in case, if fate dictates, the knight decides to stop at the window and strike up a conversation. After all, he could hardly be frank and honest about his intentions or feelings if he believed that someone might be listening.

The art expert may have more to say. He might begin by explaining the romantic symbolism contained in Pre-Raphaelite paintings: how, in the painting, the rose clinging to the wall by the window symbolises the princess's desire to cling to her prospective lover. He might go on to explain how her right hand anxiously clutches her left wrist, carefully avoiding contact with the red fabric of the vest she wears beneath her dress—a metaphor that says she 'no longer wishes to hold on to her virginity'. Indeed, a closer look at the floor shows the faintest glimpse of red creeping from beneath her dress, symbolic of the blood from her first loving encounter. And the maid looks on, furtively; realising that these may be the final moments of her employment if the desires of her mistress are fulfilled.

The esotericist will labour longer, in the knowledge that only a human-being filled with God could produce such a beautiful piece of art. He would appreciate instinctively that no individual achieves anything. It is the Godly energy within the individual that achieves. A swallow cannot fly through the branches of a tree at 100 miles per hour. It is not the bird that flies. It is not the bird-brain that achieves. It is God within the bird that flies so miraculously. The esotericist understands the true purpose of life, the higher knowledge, the super-science of the Sun and the higher orders of spirituality. He is eager to share his knowledge with the like-minded and at the same time protect it from the profane. He exists in the spiritual dimension above and away from the profane. It is

The Secrets in the Painting

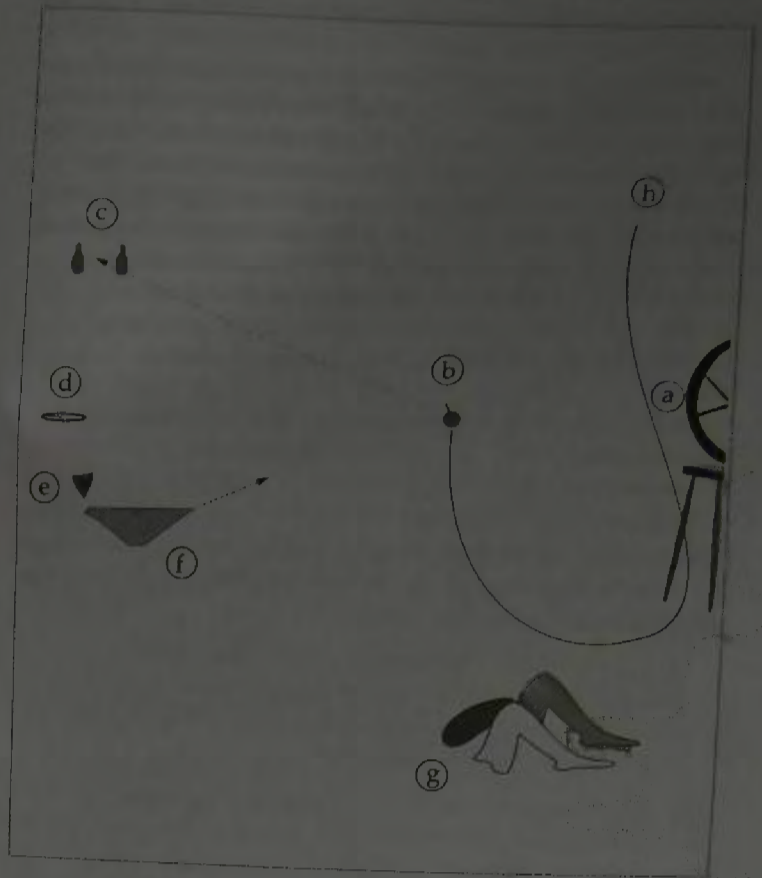

Figure 42. (a) Compasses of the Freemason (set at 66°) representing God, the Great Architect of the Universe. (b) The Sun, on its axis. (c) Twins, representing Venus, the morning star and the evening star. (d) Vagina. (e) Bikini line. (f) Arrow pointing to the vulva of the Princess, the Sun and Heaven. (g) Lovers entwined. (h) Silver thread, the cable-tow. The painting contains a secret story explaining the mysteries of life.

(1916) and its schematic, figure 42, demonstrate how they went about encoding esoteric information into their works.

The art lover sees only a good-quality picture of a princess anxiously waiting for her knight in shining armour to pass by. It seems that the chambermaid has been ushered behind the curtain, to take a break from spinning—just in case, if fate dictates, the knight decides to stop at the window and strike up a conversation. After all, he could hardly be frank and honest about his intentions or feelings if he believed that someone might be listening.

The art expert may have more to say. He might begin by explaining the romantic symbolism contained in Pre-Raphaelite paintings: how, in the painting, the rose clinging to the wall by the window symbolises the princess's desire to cling to her prospective lover. He might go on to explain how her right hand anxiously clutches her left wrist, carefully avoiding contact with the red fabric of the vest she wears beneath her dress—a metaphor that says she 'no longer wishes to hold on to her virginity'. Indeed, a closer look at the floor shows the faintest glimpse of red creeping from beneath her dress, symbolic of the blood from her first loving encounter. And the maid looks on, furtively, realising that these may be the final moments of her employment if the desires of her mistress are fulfilled.

The esotericist will labour longer, in the knowledge that only a human being filled with God could produce such a beautiful piece of art. He would appreciate instinctively that no individual achieves anything. It is the godly energy within the individual that achieves. A swallow cannot fly through the branches of a tree at 100 miles per hour. It is not the bird that flies. It is not the bird brain that achieves. It is God within the bird that flies so miraculously. The esotericist understands the true purpose of life, the higher knowledge, the super-science of the Sun and the higher orders of spirituality. He is eager to share his knowledge with the like-minded and at the same time protect it from the profane. He exists in the spiritual dimension above and away from the profane. It is as though the intellectual body hitches itself to the spiritual and in so doing experiences consciousness free of physical or emotional restraint. This capability is not open to lower initiates but only to the higher adepts who have progressed through disciplined study of the sacred sciences, years of devotion and probation.

The Secrets in the Painting

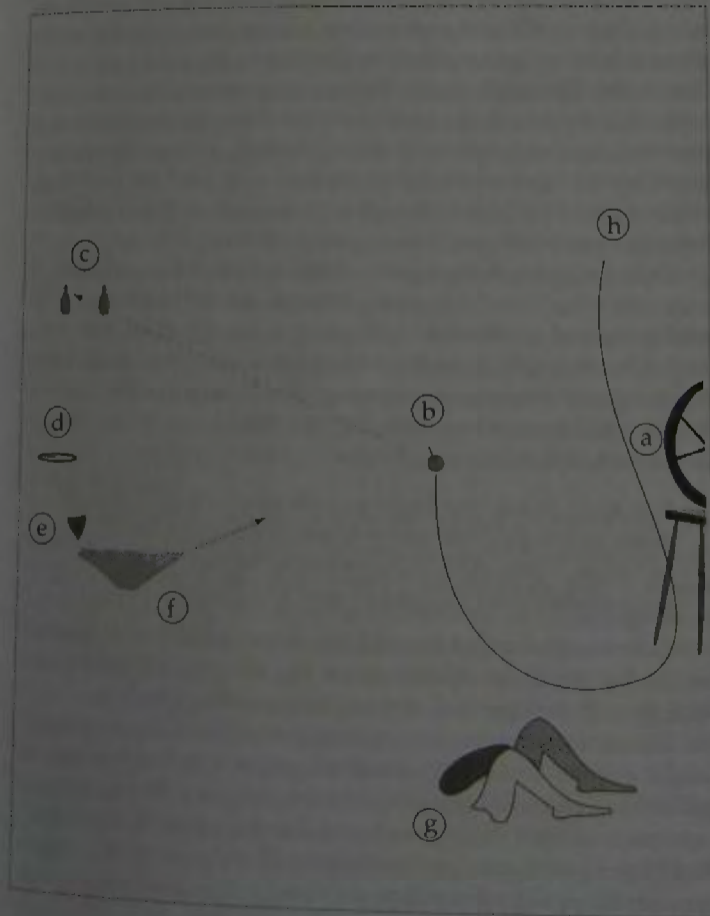

Figure 42. (a) Compasses of the Freemason (set at 66°) representing God, the Great Architect of the Universe. (b) The Sun, on its axis. (c) Twins, representing Venus, the morning star and the evening star. (d) Vagina. (e) Bikini line. (f) Arrow pointing to the vulva of the Princess, the Sun and Heaven. (g) Lovers entwined. (h) Silver thread, the cable-tow. The painting contains a secret story explaining the mysteries of life.

as though the intellectual body hitches itself to the spiritual and in so doing experiences consciousness free of physical or emotional restraint. This capability is not open to lower initiates but only to the higher adepts who have progressed through disciplined study of the sacred sciences, years of devotion and probation.

Temporary evacuation of the soul from the body results from a three-fold technique obtainable only by disciplined meditation and ritual which teaches men how to function away from the physical body at will. They teach that the spiritual nature, the soul, is attached to the physical form at certain points, symbolised by the three nails of the Crucifixion. Through initiation they are taught to withdraw the nails, enable the divine nature of man to come down from the cross and thereby release their own soul from their body into another dimension. Out-of-body-experiences are possible only once the emotional, intellectual and physical bodies are at peace and equilibrium which in turn is achieved through the meditation and ritual.

During an out-of-body-experience the soul leaves the body through a mythical silver thread that, with practice, extends from the navel. The journeying soul can leave the body safely, providing the higher intellect holds this umbilical cord tight to provide a return path to the body. The practise is dangerous, as breakage of the silver thread precludes its return to the body. Should this happen then the initiate would die. Ecclesiastes, in the Bible, says this:

Man goeth to his long home and the mourners go about the streets: or ever the silver cord be loosed or the golden bowl (halo) be broken... then shall the dust return to the Earth as it was; and the spirit shall return to God who gave it (*Ecclesiastes XII, 5-7*).

The reason for the look of fear and trepidation on the face of the maid behind the curtain now becomes clear. The silver thread, passing as it does through the open legs of the spinning wheel, adds to the story; she is fearful that her princess will submit to desire, fearful that the knight will find Heaven between her legs. She fears that her mistress will sell her soul to desire and attachment and perish. She too sees the passionate embrace on the floor, beneath her long flowing dress, wrestling in each others arms and holds tight to the silver cord that extends from her

Temporary evacuation of the soul from the body results from a three-fold technique obtainable only by disciplined meditation and ritual which teaches men how to function away from the physical body at will. They teach that the spiritual nature, the soul, is attached to the physical form at certain points, symbolised by the three nails of the Crucifixion. Through initiation they are taught to withdraw the nails, enable the divine nature of man to come down from the cross and thereby release their own soul from their body into another dimension. Out-of-body experiences are possible only once the emotional, intellectual and physical bodies are at peace and equilibrium which in turn is achieved through the meditation and ritual.

During an out-of-body experience the soul leaves the body through a mythical silver thread that, with practice, extends from the navel. The journeying soul can leave the body safely, providing the higher intellect holds this umbilical cord tight to provide a return path to the body. The practise is dangerous, as breakage of the silver thread precludes its return to the body. Should this happen, then the initiate would die. Ecclesiastes, in the Bible, says this:

Man goeth to his long home and the mourners go about the streets: or ever the silver cord be loosed or the golden bowl (halo) be broken... then shall the dust return to the Earth as it was; and the spirit shall return to God who gave it. (*Ecclesiastes XII, 5-7*)

The reason for the look of fear and trepidation on the face of the maid behind the curtain now becomes clear. The silver thread, passing as it does through the open legs of the spinning wheel, adds to the story; she is fearful that her princess will submit to desire, fearful that the knight will find Heaven between her legs. She fears that her mistress will sell her soul to desire and attachment and perish. She too sees the passionate embrace on the floor, beneath her long flowing dress, wrestling in each others arms and holds tight to the silver cord that extends from her navel in a vain attempt to tether her mistress to Earth—one last-gasp effort to save her mistress from selling her soul to oblivion as the Holy Ghost, her veil, clings to her head for dear life. Her desire, like King Arthur's, can only lead to anger, delusion and self-destruction.

So the painting has more to say to the spiritually pre-disposed than first meets the eye.

navel in the a vain attempt to tether her mistress to Earth—one last-gasp effort to save her mistress from selling her soul to oblivion as the Holy Ghost, her veil, clings to her head for dear life. Her desire, like King Arthur's, can only lead to anger, delusion and self destruction.

So the painting has more to say to the spiritually pre-disposed than first meets the eye.

In the same way, the Pre-Raphaelite painting *Summoned to the Quest by a Damsel* by Edward Burne-Jones, 1898 (plate 17) has more to say. To the art lover it is simply a gathering of King Arthur and eight of his Knights commemorating the Last Supper of Christ. The mysterious empty seat, known as the Siege Perilous (next to Arthur), as we have heard, belonged to his 'right-hand man', the knight who would one day return with the Holy Grail. However, close inspection of the scene reveals that the sheet, draped over the chair, carries a mysterious inscription, in Latin, that reads 'CCCCLIII - Hiemius Peractis . Post . Natum . Umn . Nos trum - I - C . Oportet . Hanc . Sede . Compleri': 'In the year of our Lord AD 453 winter is over. It is right and proper for this seat to be occupied'—meaning 'the dark days are over, the Holy Grail [the cup of light] has been found'.

Edward Burne-Jones, as part of the Brotherhood, would not have included the quotation into the picture if it were meaningless. The picture is, once again, another classic example of artistic beauty and the artist again clearly filled with Godly energy. In the scene a damsel beckons, by the side of the returning knight's horse, saying 'come and look at the Grail'.

The date of AD 453 fits in with the version of events that says Galahad 'took our Lord's body between his hands more than 300 years after Joseph's death, and then he died'. Joseph likely died in around AD 64, after building the church at Glastonbury. If the inscription on the fabric over the chair is correct then it supports the account, AD 453 being 'more than 300 years after the death of Joseph of Aramathea'.

It is not just the Pre-Raphaelites who have more to convey; plate 19 shows a mediaeval painting featured in the French manuscript *Livre de Messire Lancelot du lac* (by Gautier de Moap Ms. Francais 120 fol. 524v). This one is even more revealing in regard to the legends of King Arthur. Again we see Arthur at the Round Table this time accompanied by his 9 Knights. They behold the cup of light in the middle of the table. The cup

In the same way, the Pre-Raphaelite painting *Summoned to the Quest by a Damsel* by Edward Burne-Jones, 1898 (plate 17), has more to say. To the art lover it is simply a gathering of King Arthur and eight of his knights commemorating the Last Supper of Christ. The mysterious empty seat, known as the Siege Perilous (next to Arthur), as we have heard, belonged to his 'right-hand man', the knight who would one day return with the Holy Grail. However, close inspection of the scene reveals that the sheet, draped over the chair, carries a mysterious inscription, in Latin, that reads 'CCCCLIII - Hiemius Peractis . Post . Natum . Umn . Nos trum - I - C . Oportet . Hanc . Sede . Compleri': 'In the year of our Lord AD 453 winter is over. It is right and proper for this seat to be occupied'—meaning 'the dark days are over, the Holy Grail [the cup of light] has been found'.

Edward Burne-Jones, as part of the Brotherhood, would not have included the quotation in the picture if it were meaningless. The picture is, once again, another classic example of artistic beauty and the artist again clearly filled with godly energy. In the scene a damsel beckons, by the side of the returning knight's horse, saying 'come and look at the Grail'.

The date of AD 453 fits in with the version of events that says Galahad 'took our Lord's body between his hands more than 300 years after Joseph's death, and then he died'. Joseph likely died in around AD 64, after building the church at Glastonbury. If the inscription on the fabric over the chair is correct, then it supports the account, AD 453 being 'more than 300 years after the death of Joseph of Arimathea'.

It is not just the Pre-Raphaelites who have more to convey; plate 19 shows a mediaeval painting featured in the French manuscript *Livre de Messire Lancelot du lac* (by Gautier de Moap, Ms. Francais 120 fol. 524v). This one is even more revealing in regard to the legends of King Arthur. Again we see Arthur at the Round Table, this time accompanied by his nine knights. They behold the cup of light in the middle of the table. The cup is flanked by two golden anthropomorphic dragon-angels and light radiates from the cup in all directions. The floor within the circular table is again chequered and squared, indicating esoteric importance.

Curiously, and enigmatically, Arthur appears twice in the same picture—at the same time—as though in time-lapse, in the left-hand-panel

is flanked by two golden anthropomorphic dragon-angels and light radiates from the cup in all directions. The floor within the circular table is again chequered and squared indicating esoteric importance.

Curiously, and enigmatically, Arthur appears *twice* in the same picture—at the same time—as though in time-lapse, in the left-hand panel window. He wears the same clothes at the table as he does outside—at the same time. Outside he can be seen pulling a sword from the stone. Now the Arthurian legends fuse together. The story of worshipping the Grail is *inextricably linked* with the event of pulling the sword from the stone, which can only mean that the act of pulling the sword from the stone led to the discovery of the Grail. This understanding is crucial if we are to understand the esoteric significance of the Arthurian so-called legends. Moreover, if we recall, Malory suggests that the Grail was found only after Guinevere returned Excalibur—which could only happen after Excalibur had firstly been removed from the stone.

The Secrets of the Tara Brooch

The Tara brooch (plate 20) is one of the most famous of more than 50 known Celtic brooches. It was found on the beach at the mouth of the river Boyne near Bettystown, County Meath in 1850 and passed to a firm of Jewellers, Waterhouse and Company, of Dublin, who named it Tara (after the name of the ancient Irish seat of Kings located north-west of Dublin) simply to enhance its value. Archaeologists believe the brooch must have been manufactured in around AD 700 because the artistic style is similar to that embodied in the illuminated manuscripts. But this need not be the case, as we shall see.

There are two styles of brooch, thought to have been used as cloak fasteners from around AD 450 to AD 950. Figure 43 demonstrates the different principles of the various mechanisms; the penannular (figure 43a) type of brooch vary in size but are typically 5–10cm (2–4 inches) in diameter, consisting of 'almost a ring' which is split at the lower part to facilitate the through-passage of a swinging pin and the second version, thought to have appeared later, the ring brooch (figure 43b) where a piece of metal bridges the split in the ring or, alternatively, like the Tara Brooch, where the ring continues unbroken along the entire circumference.

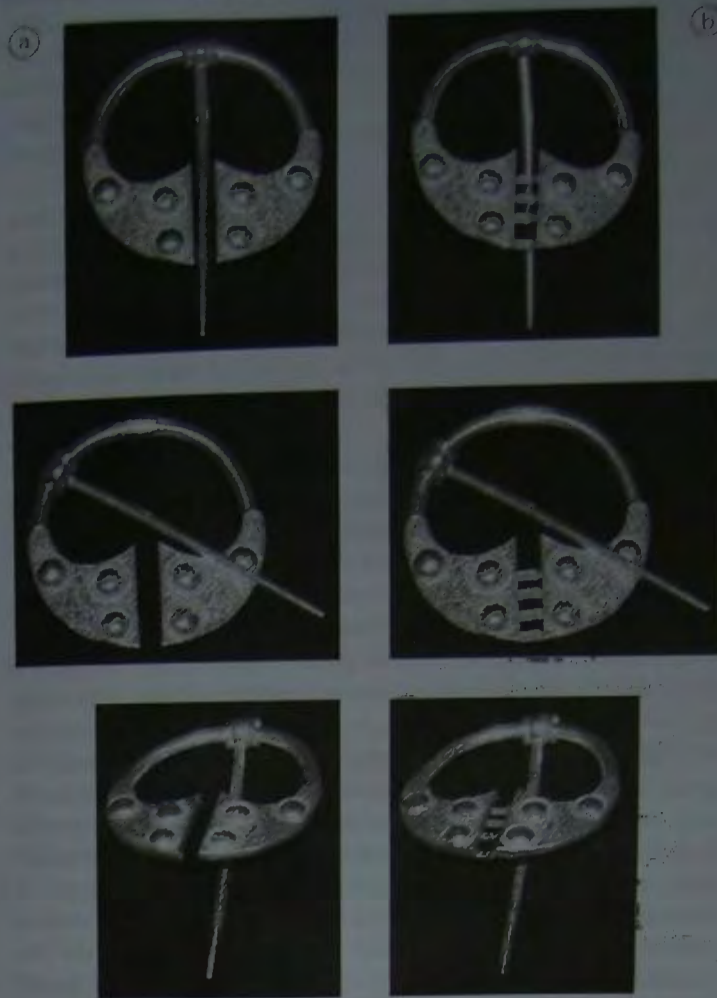

Figure 43. (a) The Penannular style of brooch was broken at one point of the ring facilitating the through-passage of the fastening pin. (b) The Ring brooch was either a continuous ring or, as shown here, bridged by connecting bars. The pin could not pass through the ring, although it could be flipped-over (for demonstration purposes) when not in use, as shown here (right).

A LAND WITHOUT A KING

window. He wears the same clothes at the table as he does outside—at the same time. Outside he can be seen pulling a sword from the stone. Now the Arthurian legends fuse together. The story of worshipping the Grail is *inextricably linked* with the event of pulling the sword from the stone, which can only mean that the act of pulling the sword from the stone led to the discovery of the Grail. This understanding is crucial if we are to understand the esoteric significance of the Arthurian so-called legends. Moreover, if we recall, Malory suggests that the Grail was found only after Guinevere returned Excalibur—which could only happen after Excalibur had firstly been removed from the stone.

The Secrets of the Tara Brooch

The Tara brooch (plate 20) is one of the most famous of more than fifty known Celtic brooches. It was found on the beach at the mouth of the river Boyne near Bettystown, County Meath, in 1850 and passed to a firm of jewellers, Waterhouse and Company, of Dublin, who named it Tara (after the name of the ancient Irish seat of kings located north-west of Dublin) simply to enhance its value. Archaeologists believe the brooch must have been manufactured in around AD 700 because the artistic style is similar to that embodied in the illuminated manuscripts. But this need not be the case, as we shall see.

There are two styles of brooch, thought to have been used as cloak fasteners from around AD 450 to AD 950. Figure 43 demonstrates the different principles of the various mechanisms. The penannular (figure 43a) type of brooch varies in size but is typically 5–10 cm (2–4 inches) in diameter, consisting of 'almost a ring' which is split at the lower part to facilitate the through passage of a swinging pin and the second version, thought to have appeared later, the ring brooch (figure 43b) where a piece of metal bridges the split in the ring or, alternatively, like the Tara brooch, where the ring continues unbroken along the entire circumference.

Clearly the two types of mechanism operated differently. The small pin on the penannular was firstly stabbed through the two pieces of fabric toward the chest and then back through the fabric away from the chest to the front side. The pin could then be passed through the

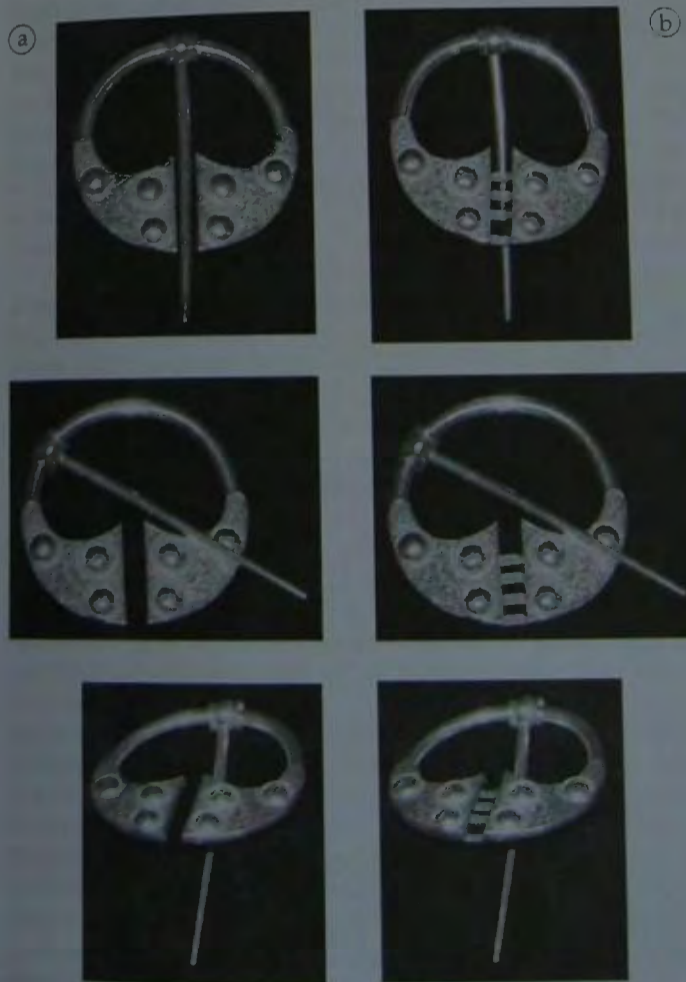

Figure 43. (a) The penannular style of brooch was broken at one point of the ring facilitating the through passage of the fastening pin. (b) The ring brooch was either a continuous ring or, as shown here, bridged by connecting bars. The pin could not pass through the ring, although it could be flipped-over (for demonstration purposes) when not in use, as shown here (right).

Clearly the two types of mechanism operated differently. The small pin on the penannular was firstly stabbed through the two pieces of fabric toward the chest and then back through the fabric away from the chest to the front side. The pin could then be passed through the gap in the ring and then slid around the ring, the end of the pin resting, stressed, on the ring of the brooch. The pin thus fastened the two pieces of fabric together.

The later ring brooches are, generally, much larger than the simple penannular ones. The pin on the Tara brooch, for example, is 32cm (12.6 inches) long [*Treasures of the National Museum of Ireland*, Gill and Macmillan, 2002] and the ring diameter, [scaled from the computer using the 32cm (12.6-inch) pin as a reference], measures 14.84cm (5.84 inches) [although the diameter given in the *Treasures of the National Museum of Ireland* is 8.7cm (3.42 inches) which, following visual inspection of the brooch, cannot be correct].

The pin on the Tara brooch is far too large to stab through the fabric without causing substantial damage to the material. However, experiments with the smaller ring brooch (figure 43b) show that it can be used to hold two pieces of fabric together using a different method to that used by the penannular. The same method could therefore be used with the Tara brooch; starting with the brooch in front of the chest, one of the tri-angular ends of a cloak is firstly passed from the front through the ring, under the pin and back out through the front of the ring. The large pin is then slid around the ring so as to crush the fabric already in the ring (thus opening-up an empty gap on the other side of the ring). The second corner of the cloak is now passed through the empty gap in the ring, under the pin (as before) and again out through the front of the ring. Both corners of the fabric are then gripped by the hands and pulled apart, from centre to shoulders, which forces the larger parts of the cloak into the ring where they jam tight. The main pin is thus required to travel around the ring, within limits, and to move forwards and backwards.

This demonstrates that the enormous Tara brooch, could, theoretically, be used as a cloak fastener. The idea being that once fastened the cloak is pulled sideways so that the brooch settles below the shoulder. Which is all very well, unless the wearer should fall over and become impaled on the massive 32-cm (12.6-inch) pin. Immediately, the rational observer

gap in the ring and then slid around the ring, the end of the pin resting, stressed, on the ring of the brooch. The pin thus fastened the two pieces of fabric together.

The later ring brooches are, generally, much larger than the simple penannular ones. The pin on the Tara brooch, for example, is 32 cm (12.6 inches) long [*Treasures of the National Museum of Ireland*, Gill and Macmillan, 2002] and the ring diameter [scaled from the computer using the 32-cm (12.6-inch) pin as a reference] measures 14.84 cm (5.84 inches) [although the diameter given in the *Treasures of the National Museum of Ireland* is 8.7 cm (3.42 inches) which, following visual inspection of the brooch, cannot be correct].

The pin on the Tara brooch is far too large to stab through the fabric without causing substantial damage to the material. However, experiments with the smaller ring brooch (figure 43b) show that it can be used to hold two pieces of fabric together using a different method to that used by the penannular. The same method could therefore be used with the Tara brooch: starting with the brooch in front of the chest, one of the triangular ends of a cloak is firstly passed from the front through the ring, under the pin and back out through the front of the ring. The large pin is then slid around the ring so as to crush the fabric already in the ring (thus opening-up an empty gap on the other side of the ring). The second corner of the cloak is now passed through the empty gap in the ring, under the pin (as before) and again out through the front of the ring. Both corners of the fabric are then gripped by the hands and pulled apart, from centre to shoulders, which forces the larger parts of the cloak into the ring where they jam tight. The main pin is thus required to travel around the ring, within limits, and to move forwards and backwards.

This demonstrates that the enormous Tara brooch could, theoretically, be used as a cloak fastener, the idea being that once fastened, the cloak is pulled sideways so that the brooch settles below the shoulder. Which is all very well, unless the wearer should fall over and become impaled on the massive 32-cm (12.6-inch) pin. Immediately, the rational observer questions the real purpose of the massive so-called ring brooches.

The main ring and pin of the Tara brooch are made of gold-plated silver, the gilt being much worn with time. The front consists of several

questions the real purpose of the massive so-called ring brooches.

The main ring and pin of the Tara brooch are made of gold-plated silver, the gilt being much worn with time. The front comprises of several recessed panels decorated with gold filigree interspersed with stones of glass, enamel and amber. One of the panels is missing, revealing a tiny metal stud that holds a back-panel into position. Solid surfaces are finely engraved.

The ring carries several cast animals and birds; two baby dragonheads project outwards from the horizontal centre-line of the main circular ring (plates 21a and f, and 22e). One dragonhead (plate 21a) grips a carved cast swinging-buckle hinged between its teeth. The other side of the buckle attaches to a tapered snake-like zoomorphic-style safety-chain made of woven gilt wire, the head-end of which grips the buckle between its teeth (plate 21b). The head of the creature is similar to the dragonhead that Cernunnos carries in his left hand in the Gundestrup Cauldron [c. 100 BC] (figure 20). The buckle itself sports two tiny black glass human heads, vertically mirror imaged (plate 21d). Two entwined vulture heads hang over the centre of the ring (plate 21e and figure 22f). Two more heads project from either side of the main ring (figure 21i and j). The heads at first appear to be dragon-like but the associated long neck is smooth, without scales, more like the neck and head of a bird, perhaps a pelican. In any event they are 'feathered-snakes', another pair, without the neck loop are seen entwined on the lower ring (plate 22d).

The lower part of the wedge-shaped brooch pin is decorated with the head and face of a stag with stylised antlers (plates 20a, and 22i) comprised of several engraved panels each separated with stones of different shape, style and colour.

Clearly, the brooch has many spiritual associations; the appearance of the stag's head shares much in common with Cernunnos, the Celtic god known to have been worshipped in around 100 BC who is associated with Christ; the dragon-like safety-chain again associates the piece with Cernunnos and the feathered-snake (part bird, part snake and part stag). And the brooch has astronomical associations; the two tiny black mirror-imaged glass heads on the buckle, with the twins of Venus; the vulture heads, with those of Tutankhamun (who was also known as the feathered-snake, the 'Son of God' who carried the vulture on his forehead);

recessed panels decorated with gold filigree interspersed with stones of glass, enamel and amber. One of the panels is missing, revealing a tiny metal stud that holds a back panel in position. Solid surfaces are finely engraved.

The ring carries several cast animals and birds; two baby dragonheads project outwards from the horizontal centre-line of the main circular ring (plates 21a and f, and 22e). One dragon head (plate 21a) grips a carved cast swinging buckle hinged between its teeth. The other side of the buckle attaches to a tapered snake-like zoomorphic-style safety chain made of woven gilt wire, the head end of which grips the buckle between its teeth (plate 21b). The head of the creature is similar to the dragon head that Cernunnos carries in his left hand in the Gundestrup Cauldron [c. 100 BC] (figure 22). The buckle itself sports two tiny black glass human heads, vertically mirror imaged (plate 21d). Two entwined vulture heads hang over the centre of the ring (plate 21e and plate 22f). Two more heads project from either side of the main ring (plate 21i and j). The heads at first appear to be dragon-like but the associated long neck is smooth, without scales, more like the neck and head of a bird, perhaps a pelican. In any event they are 'feathered snakes'; another pair, without the neck loop (plate 22d), are seen entwined on the lower ring.

The lower part of the wedge-shaped brooch pin is decorated with the head and face of a stag with stylised antlers (plates 20a and 22j) comprising several engraved panels, each separated with stones of different shape, style and colour.

Clearly, the brooch has many spiritual associations: the appearance of the stag's head has much in common with Cernunnos, the Celtic god known to have been worshipped in around 100 BC who is associated with Christ; the dragon-like safety chain again associates the piece with Cernunnos and the feathered snake (part bird, part snake and part stag). And the brooch has astronomical associations: the two tiny black mirror-imaged glass heads on the buckle, with the twins of Venus; the vulture heads, with those of Tutankhamun (who was also known as the feathered snake, the 'Son of God' who carried the vulture on his forehead); and the dragon/pelican heads (if that is what they are) with the feathered snake and the constellation of Orion [in Peru] and resurrection.

Clearly the two types of mechanism operated differently. The small pin on the penannular was firstly stabbed through the two pieces of fabric toward the chest and then back through the fabric away from the chest to the front side. The pin could then be passed through the gap in the ring and then slid around the ring, the end of the pin resting, stressed, on the ring of the brooch. The pin thus fastened the two pieces of fabric together.

The later ring brooches are, generally, much larger than the simple penannular ones. The pin on the Tara brooch, for example, is 32cm (12.6 inches) long [*Treasures of the National Museum of Ireland*, Gill and Macmillan, 2002] and the ring diameter, [scaled from the computer using the 32cm (12.6-inch) pin as a reference], measures 14.84cm (5.84 inches) [although the diameter given in the *Treasures of the National Museum of Ireland* is 8.7cm (3.42 inches) which, following visual inspection of the brooch, cannot be correct].

The pin on the Tara brooch is far too large to stab through the fabric without causing substantial damage to the material. However, experiments with the smaller ring brooch (figure 43b) show that it can be used to hold two pieces of fabric together using a different method to that used by the penannular. The same method could therefore be used with the Tara brooch; starting with the brooch in front of the chest, one of the triangular ends of a cloak is firstly passed from the front through the ring, under the pin and back out through the front of the ring. The large pin is then slid around the ring so as to crush the fabric already in the ring (thus opening-up an empty gap on the other side of the ring). The second corner of the cloak is now passed through the empty gap in the ring, under the pin (as before) and again out through the front of the ring. Both corners of the fabric are then gripped by the hands and pulled apart, from centre to shoulders, which forces the larger parts of the cloak into the ring where they jam tight. The main pin is thus required to travel around the ring, within limits, and to move forwards and backwards.

This demonstrates that the enormous Tara brooch, could, theoretically, be used as a cloak fastener. The idea being that once fastened the cloak is pulled sideways so that the brooch settles below the shoulder. Which is all very well, unless the wearer should fall over and become impaled on the massive 32-cm (12.6-inch) pin. Immediately, the rational observer

gap in the ring and then slid around the ring, the end of the pin resting, stressed, on the ring of the brooch. The pin thus fastened the two pieces of fabric together.

The later ring brooches are, generally, much larger than the simple penannular ones. The pin on the Tara brooch, for example, is 32 cm (12.6 inches) long [*Treasures of the National Museum of Ireland*, Gill and Macmillan, 2002] and the ring diameter [scaled from the computer using the 32-cm (12.6-inch) pin as a reference] measures 14.84 cm (5.84 inches) [although the diameter given in the *Treasures of the National Museum of Ireland* is 8.7 cm (3.42 inches) which, following visual inspection of the brooch, cannot be correct].

The pin on the Tara brooch is far too large to stab through the fabric without causing substantial damage to the material. However, experiments with the smaller ring brooch (figure 43b) show that it can be used to hold two pieces of fabric together using a different method to that used by the penannular. The same method could therefore be used with the Tara brooch: starting with the brooch in front of the chest, one of the triangular ends of a cloak is firstly passed from the front through the ring, under the pin and back out through the front of the ring. The large pin is then slid around the ring so as to crush the fabric already in the ring (thus opening-up an empty gap on the other side of the ring). The second corner of the cloak is now passed through the empty gap in the ring, under the pin (as before) and again out through the front of the ring. Both corners of the fabric are then gripped by the hands and pulled apart, from centre to shoulders, which forces the larger parts of the cloak into the ring where they jam tight. The main pin is thus required to travel around the ring, within limits, and to move forwards and backwards.

This demonstrates that the enormous Tara brooch could, theoretically, be used as a cloak fastener, the idea being that once fastened, the cloak is pulled sideways so that the brooch settles below the shoulder. Which is all very well, unless the wearer should fall over and become impaled on the massive 32-cm (12.6-inch) pin. Immediately, the rational observer questions the real purpose of the massive so-called ring brooches.

The main ring and pin of the Tara brooch are made of gold-plated silver, the gilt being much worn with time. The front consists of several

questions the real purpose of the massive so-called ring brooches.

The main ring and pin of the Tara brooch are made of gold-plated silver, the gilt being much worn with time. The front comprises of several recessed panels decorated with gold filigree interspersed with stones of glass, enamel and amber. One of the panels is missing, revealing a tiny metal stud that holds a back panel into position. Solid surfaces are finely engraved.

The ring carries several cast animals and birds; two baby dragonheads project outwards from the horizontal centre-line of the main circular ring (plates 21a and f, and 22e). One dragonhead (plate 21a) grips a carved cast swinging-buckle hinged between its teeth. The other side of the buckle attaches to a tapered snake-like zoomorphic-style safety chain made of woven gilt wire, the head-end of which grips the buckle between its teeth (plate 21b). The head of the creature is similar to the dragonhead that Cernunnos carries in his left hand in the Gundestrup Cauldron [c. 100 BC] (figure 20). The buckle itself sports two tiny black glass human heads, vertically mirror imaged (plate 21d). Two entwined vulture heads hang over the centre of the ring (plate 21e and figure 22f). Two more heads project from either side of the main ring (figure 21i and j). The heads at first appear to be dragon-like but the associated long neck is smooth, without scales, more like the neck and head of a bird, perhaps a pelican. In any event they are 'feathered-snakes', another pair, without the neck loop are seen entwined on the lower ring (plate 22d).

The lower part of the wedge-shaped brooch pin is decorated with the head and face of a stag with stylised antlers (plates 20a, and 22i) comprised of several engraved panels each separated with stones of different shape, style and colour.

Clearly, the brooch has many spiritual associations; the appearance of the stag's head shares much in common with Cernunnos, the Celtic god known to have been worshipped in around 100 BC who is associated with Christ; the dragon-like safety-chain again associates the piece with Cernunnos and the feathered-snake (part bird, part snake and part stag). And the brooch has astronomical associations; the two tiny black mirror-imaged glass heads on the buckle, with the twins of Venus; the vulture heads, with those of Tutankhamun (who was also known as the feathered-snake, the 'Son of God' who carried the vulture on his forehead):

recessed panels decorated with gold filigree interspersed with stones of glass, enamel and amber. One of the panels is missing, revealing a tiny metal stud that holds a back panel in position. Solid surfaces are finely engraved.

The ring carries several cast animals and birds; two baby dragon heads project outwards from the horizontal centre-line of the main circular ring (plates 21a and f, and 22e). One dragon head (plate 21a) grips a carved cast swinging buckle hinged between its teeth. The other side of the buckle attaches to a tapered snake-like zoomorphic-style safety chain made of woven gilt wire, the head end of which grips the buckle between its teeth (plate 21b). The head of the creature is similar to the dragon head that Cernunnos carries in his left hand in the Gundestrup Cauldron [c. 100 BC] (figure 22). The buckle itself sports two tiny black glass human heads, vertically mirror imaged (plate 21d). Two entwined vulture heads hang over the centre of the ring (plate 21e and plate 22f). Two more heads project from either side of the main ring (plate 21i and j). The heads at first appear to be dragon-like but the associated long neck is smooth, without scales, more like the neck and head of a bird, perhaps a pelican. In any event they are 'feathered snakes'; another pair, without the neck loop (plate 22d), are seen entwined on the lower ring.

The lower part of the wedge-shaped brooch pin is decorated with the head and face of a stag with stylised antlers (plates 20a and 22j) comprising several engraved panels, each separated with stones of different shape, style and colour.

Clearly, the brooch has many spiritual associations: the appearance of the stag's head has much in common with Cernunnos, the Celtic god known to have been worshipped in around 100 BC who is associated with Christ; the dragon-like safety chain again associates the piece with Cernunnos and the feathered snake (part bird, part snake and part stag). And the brooch has astronomical associations: the two tiny black mirror-imaged glass heads on the buckle, with the twins of Venus; the vulture heads, with those of Tutankhamun (who was also known as the feathered snake, the 'Son of God' who carried the vulture on his forehead); and the dragon/pelican heads (if that is what they are) with the feathered snake and the constellation of Orion [in Peru] and resurrection.

and the dragon/pelican heads (if that is what they are) with the feathered-snake and the constellation of Orion (in Peru) and resurrection.

Indeed, closer examination of the main-ring dragonheads (21a and 21f) shows them to be identical to a pair (plate 21g) found on the jade headrest of Prince Liu Sheng, the nephew of Ch'in Shi Huangdi (the Son of Heaven whose insignia was the dragon) the First Emperor of China. The hole at the top of the jade burial suit allowed for the release of the Soul.

In *The Terracotta Warriors I* showed how the arrangements of jade platelets in the spherical head-gear concealed the super-science of the Sun (figure 44). Here again, in the Tara brooch, a baby dragonhead looks out from either side of a circular ring, suggesting that the Tara Brooch might likewise conceal astronomical information beyond the obvious already mentioned.

With this in mind the brooch can be examined in greater detail (plate 22); the central ring (plate 22a) represents the Sun. Mercury, the closest planet to the Sun, can be seen closest to the solar equator. Moving outwards, away from the Sun, the next to appear is Venus, in its manifestation as the twin planet, a circle either side of Mercury on the solar equator. Moving out from Venus the Earth is shown as a blue square, as it is in China. The Moon can be seen below in its orbit around the Earth.

The looping dragon/pelican neck and heads (plate 22d—either side of the main ring) contain within them the manifestation of Venus in both of its emanations as the morning star and the evening star in the heavens (also shown inside boxes plate 22b and 22c) either side of [the main ring] the Sun.

A downward 'flapping-wings' symbol is created by three stones (shown in brown) beneath the entwined vulture heads (plate 22f). A similar symbolic flapping-wing arrangement appears above the lower pair of dragon/pelican heads (plate 22d, and both pairs are shown boxed in plate 22g) confirming that the juxtaposed creatures are indeed meant to be interpreted as birds (vultures and pelicans).

Altogether there are 6 [brown] wing shapes, two in each of the bird symbols and another two in the pin-end arrangement. There are also 6 blue square shapes and 6 circular green shapes (plate 22h) revealing the number 666.

Jade Head Gear of Prince Liu Sheng

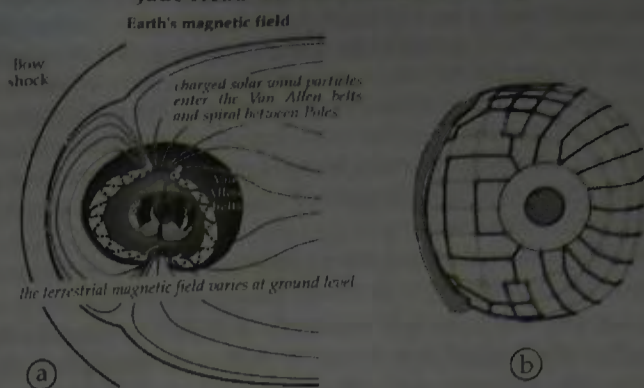

Figure 44. (a) Schematic of the Earth's magnetosphere compressed on the sunward side by the solar wind, corresponds with (b) lines on the head of the jade suit, created by intersections between the jade platelets. The circular head rests on a jade pillow that carries two dragonheads, one either side of the circular head—and the jade head itself (the circle) contains the super-science of the Sun. In the same way, the Tara Brooch carries a dragonhead either side of the main ring (plate 22 [red])—indicating that the main ring, in some way, might likewise contain the super-science of the Sun.

Plate 22i and 22j show detail of the stag's head with a halo on the crown chakra, at the top of the head, and the arrangement of antlers, in brown.

Closer examination (plate 20a) shows that the centre pin contains end-stops that correspond to end-stops on the stag's head, inviting the observer to slide the pin around the ring in either direction until it comes up against an end-stop. There must be a reason for this because the pin would stop anyway, of its own accord, as it crashed into the ring. The end-stops, thus, at first appear unnecessary and surplus to requirements. But we have to remind ourselves that the ancients never did anything without a good reason. This amounts to an invitation to slide the pin around the ring and measure the angle between the pin-end stops.

Sliding the pin around the ring between the end-stops (plate 20a) reveals the angle of 144°, representing the esoteric number of 144,000, the number destined for Heaven, mentioned in Revelation.

Indeed, closer examination of the main-ring dragon heads (plates 21a and 21f) shows them to be identical to a pair (plate 21g) found on the jade headrest of Prince Liu Sheng, the nephew of Ch'in Shi Huangdi (the Son of Heaven, whose insignia was the dragon), the first emperor of China. The hole at the top of the jade burial suit allowed for the release of the Soul.

In *The Terracotta Warriors I* showed how the arrangements of jade platelets in the spherical headgear concealed the super-science of the Sun (figure 44). Here again, in the Tara brooch, a baby dragon head looks out from either side of a circular ring, suggesting that the Tara brooch might likewise conceal astronomical information beyond the obvious already mentioned.

With this in mind the brooch can be examined in greater detail (plate 22). The central ring (plate 22a) represents the Sun. Mercury, the closest planet to the Sun, can be seen closest to the solar equator. Moving outwards, away from the Sun, the next to appear is Venus, in

Jade Headgear of Prince Liu Sheng

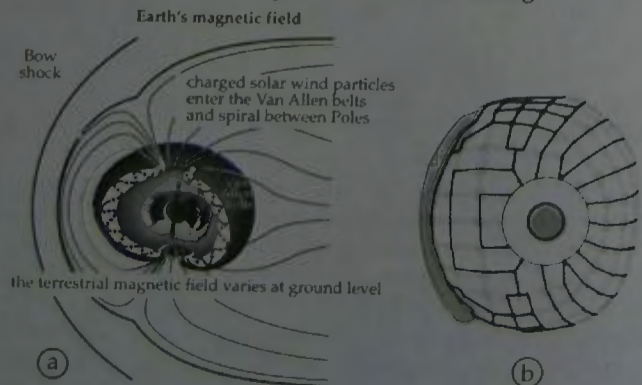

Figure 44. (a) Schematic of the Earth's magnetosphere compressed on the sunward side by the solar wind corresponds with (b) lines on the head of the jade suit, created by intersections between the jade platelets. The circular head rests on a jade pillow that carries two dragon heads, one either side of the circular head—and the jade head itself (the circle) contains the super-science of the Sun. In the same way, the Tara brooch carries a dragon head either side of the main ring (plate 22 [red])—indicating that the main ring, in some way, might likewise contain the super-science of the Sun.

its manifestation as the twin planet, a circle either side of Mercury on the solar equator. Moving out from Venus the Earth is shown as a blue square, as it is in China. The Moon can be seen below in its orbit around the Earth.

The looping dragon/pelican neck and heads (plate 22d—either side of the main ring) contain within them the manifestation of Venus in both of its emanations as the morning star and the evening star in the heavens (also shown inside boxes plate 22b and 22c) either side of [the main ring] the Sun.

A downward 'flapping-wings' symbol is created by three stones (shown in brown) beneath the entwined vulture heads (plate 22d). A similar symbolic flapping-wing arrangement appears above the lower pair of dragon/pelican heads (plate 22d), and both pairs are shown boxed in plate 22g, confirming that the juxtaposed creatures are indeed meant to be interpreted as birds (vultures and pelicans).

Altogether there are six [brown] wing shapes, two in each of the bird symbols and another two in the pin-end arrangement. There are also six blue square shapes and six circular green shapes (plate 22h), revealing the number 666.

Plate 22i and j show detail of the stag's head with a halo on the crown chakra, at the top of the head, and the arrangement of antlers, in brown.

Closer examination (plate 20a) shows that the centre pin contains end-stops that correspond to end-stops on the stag's head, inviting the observer to slide the pin around the ring in either direction until it comes up against an end-stop. There must be a reason for this because the pin would stop anyway, of its own accord, as it crashed into the ring. The end-stops, thus, at first appear unnecessary and surplus to requirements. But we have to remind ourselves that the ancients never did anything without a good reason. This amounts to an invitation to slide the pin around the ring and measure the angle between the pin end-stops.

Sliding the pin around the ring between the end-stops (plate 20a) reveals the angle of 144°, representing the esoteric number of 144,000, the number destined for Heaven, mentioned in Revelation.

That this abbreviated figure was intended to be conveyed and interpreted in this way is confirmed by measuring the angle between the antlers of the stag [Christ]. Plate 20c shows that the angle from

and the dragon/pelican heads (if that is what they are) with the feathered-snake and the constellation of Orion [in Peru] and resurrection.

Indeed, closer examination of the main-ring dragonheads (21a and 21f) shows them to be identical to a pair (plate 21g) found on the Jade headrest of Prince Liu Sheng, the nephew of Ch'in Shi Huangdi (the Son of Heaven whose insignia was the dragon) the First Emperor of China. The hole at the top of the jade burial suit allowed for the release of the Soul.

In *The Terracotta Warriors* I showed how the arrangements of jade platelets in the spherical head-gear concealed the super-science of the Sun (figure 44). Here again, in the Tara brooch, a baby dragonhead looks out from either side of a circular ring, suggesting that the Tara Brooch might likewise conceal astronomical information beyond the obvious already mentioned.

With this in mind the brooch can be examined in greater detail (plate 22): the central ring (plate 22a) represents the Sun. Mercury, the closest planet to the Sun, can be seen closest to the solar equator. Moving outwards, away from the Sun, the next to appear is Venus, in its manifestation as the twin planet, a circle either side of Mercury on the solar equator. Moving out from Venus the Earth is shown as a blue square, as it is in China. The Moon can be seen below in its orbit around the Earth.

The looping dragon/pelican neck and heads (plate 22d—either side of the main ring) contain within them the manifestation of Venus in both of its emanations as the morning star and the evening star in the heavens (also shown inside boxes plate 22b and 22c) either side of [the main ring] the Sun.

A downward 'flapping-wings' symbol is created by three stones (shown in brown) beneath the entwined vulture heads (plate 22f). A similar symbolic flapping-wing arrangement appears above the lower pair of dragon/pelican heads (plate 22d, and both pairs are shown boxed in plate 22g) confirming that the juxtaposed creatures are indeed meant to be interpreted as birds (vultures and pelicans).

Altogether there are 6 [brown] wing shapes, two in each of the bird symbols and another two in the pin-end arrangement. There are also 6 blue square shapes and 6 circular green shapes (plate 22h) revealing the number 666.

Jade Head Gear of Prince Liu Sheng

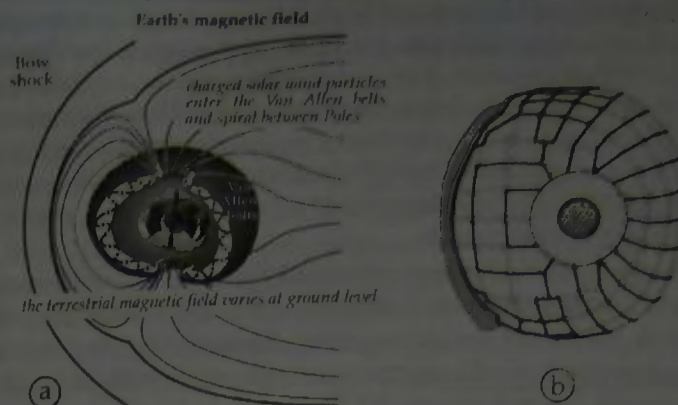

Figure 44. (a) Schematic of the Earth's magnetosphere compressed on the sunward side by the solar wind, corresponds with (b) lines on the head of the jade suit, created by intersections between the jade platelets. The circular head rests on a jade pillow that carries two dragonheads, one either side of the circular head—and the Jade head itself (the circle) contains the super-science of the Sun. In the same way, the Tara Brooch carries a dragonhead either side of the main ring (plate 22 [red])—indicating that the main ring, in some way, might likewise contain the super-science of the Sun.

Plate 22i and 22j show detail of the stag's head with a halo on the crown chakra, at the top of the head, and the arrangement of antlers, in brown.

Closer examination (plate 20a) shows that the centre pin contains end-stops that correspond to end-stops on the stag's head, inviting the observer to slide the pin around the ring in either direction until it comes up against an end-stop. There must be a reason for this because the pin would stop anyway, of its own accord, as it crashed into the ring. The end-stops, thus, at first appear unnecessary and surplus to requirements. But we have to remind ourselves that the ancients never did anything without a good reason. This amounts to an invitation to slide the pin around the ring and measure the angle between the pin-end stops.

Sliding the pin around the ring between the end-stops (plate 20a) reveals the angle of 144° , representing the esoteric number of 144,000, the number destined for Heaven, mentioned in Revelation.

A LAND WITHOUT A KING

Indeed, closer examination of the main-ring dragon heads (plates 21a and 21f) shows them to be identical to a pair (plate 21g) found on the jade headrest of Prince Liu Sheng, the nephew of Ch'in Shi Huangdi (the Son of Heaven, whose insignia was the dragon), the first emperor of China. The hole at the top of the jade burial suit allowed for the release of the Soul.

In *The Terracotta Warriors* I showed how the arrangements of jade platelets in the spherical headgear concealed the super-science of the Sun (figure 44). Here again, in the Tara brooch, a baby dragon head looks out from either side of a circular ring, suggesting that the Tara brooch might likewise conceal astronomical information beyond the obvious already mentioned.

With this in mind the brooch can be examined in greater detail (plate 22). The central ring (plate 22a) represents the Sun. Mercury, the closest planet to the Sun, can be seen closest to the solar equator. Moving outwards, away from the Sun, the next to appear is Venus, in

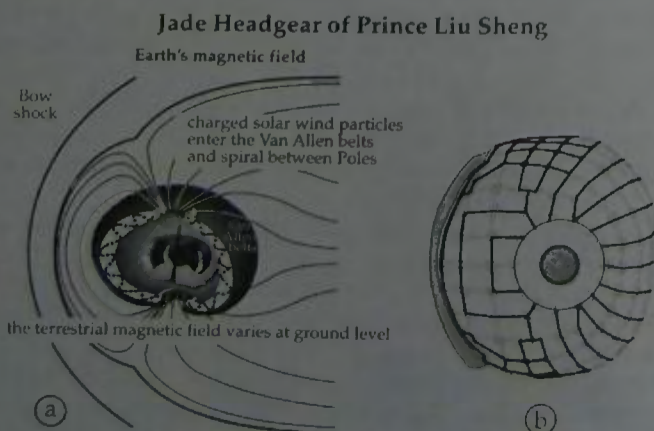

Figure 44. (a) Schematic of the Earth's magnetosphere compressed on the sunward side by the solar wind corresponds with (b) lines on the head of the jade suit, created by intersections between the jade platelets. The circular head rests on a jade pillow that carries two dragon heads, one either side of the circular head—and the jade head itself (the circle) contains the super-science of the Sun. In the same way, the Tara brooch carries a dragon head either side of the main ring (plate 22 [red])—indicating that the main ring, in some way, might likewise contain the super-science of the Sun.

A LAND WITHOUT A KING

its manifestation as the twin planet, a circle either side of Mercury on the solar equator. Moving out from Venus the Earth is shown as a blue square, as it is in China. The Moon can be seen below in its orbit around the Earth.

The looping dragon/pelican neck and heads (plate 22d—either side of the main ring) contain within them the manifestation of Venus in both of its emanations as the morning star and the evening star in the heavens (also shown inside boxes plate 22b and 22c) either side of [the main ring] the Sun.

A downward 'flapping-wings' symbol is created by three stones (shown in brown) beneath the entwined vulture heads (plate 22d). A similar symbolic flapping-wing arrangement appears above the lower pair of dragon/pelican heads (plate 22d), and both pairs are shown boxed in plate 22g, confirming that the juxtaposed creatures are indeed meant to be interpreted as birds (vultures and pelicans).

Altogether there are six [brown] wing shapes, two in each of the bird symbols and another two in the pin-end arrangement. There are also six blue square shapes and six circular green shapes (plate 22h), revealing the number 666.

Plate 22i and j show detail of the stag's head with a halo on the crown chakra, at the top of the head, and the arrangement of antlers, in brown.

Closer examination (plate 20a) shows that the centre pin contains end-stops that correspond to end-stops on the stag's head, inviting the observer to slide the pin around the ring in either direction until it comes up against an end-stop. There must be a reason for this because the pin would stop anyway, of its own accord, as it crashed into the ring. The end-stops, thus, at first appear unnecessary and surplus to requirements. But we have to remind ourselves that the ancients never did anything without a good reason. This amounts to an invitation to slide the pin around the ring and measure the angle between the pin-end-stops.

Sliding the pin around the ring between the end-stops (plate 20a) reveals the angle of 144° , representing the esoteric number of 144,000, the number destined for Heaven, mentioned in Revelation.

That this abbreviated figure was intended to be conveyed and interpreted in this way is confirmed by measuring the angle between the antlers of the stag [Christ]. Plate 20c shows that the angle from

That this abbreviated figure was intended to be conveyed and interpreted in this way is confirmed by measuring the angle between the antlers of the stag [Christ]. Plate 22c shows that the angle from the crown chakra (the pineal gland) of the antler arrangement to the vertical centre-line of the antler arrangement measures 14.4° . The antler appendages terminate in double-zeros and in-between these lies a semicircle (like the setting Sun) shared by both antlers. The antler arrangement thus yields 144,000. Confirming the efficacy of measuring the angle between the pin end-stops.

Moreover, when the pin is swung backwards, to facilitate the measurement of the angle of 144° from each pin end-stop position, we notice that the pin (which resembles a sword, figure 20b) moves, naturally, away from the [largest] stone fixed either side of the brooch front. This means that—by removing the pin (the sword) from the stone—the angle of 144° can be measured or 'he who draws the sword from the stone—and understands what is happening—becomes one of the 144,000, destined to be a King in Heaven'.

This all sounds familiar. In the Arthurian legend, whoever 'pulled the sword from the stone would become a King on Earth'. Arthur pulled the sword from the stone and became a King on Earth 'who would live again' in Heaven. Which surely means that King Arthur must have decoded the Tara brooch in the same way. The information contained within the Tara Brooch must be the foundation that supports the so-called myth contained in the Arthurian legend, which must actually be fact.

The rear of the brooch (plate 20b) is altogether more austere. Figure 45 enables analysis in greater detail: the four profile dragonheads (plate 21h) are on the obverse transformed into bony dragon skeleton heads, forming an immediate association with death. Two black semicircular stones, partially eclipsed by the main ring (figure 45a) show the rise and fall of Venus, but this time only as the 'black' evening star, emphasising darkness and death. The two large circular stones (figure 45b) are made of black glass, inlaid with 6 pieces of red glass [6, and again 6] and altogether there are 6 circular black stones (5 circular + 2 semi-circular), making 666 from the black circular stones on the obverse. The centre of each inlaid stone also embraces an equilateral triangle (666).

A LAND WITHOUT A KING

the crown chakra (the pineal gland) of the antler arrangement to the vertical centre-line of the antler arrangement measures 14.4° . The antler appendages terminate in double zeros and in between these lies a semicircle (like the setting Sun) shared by both antlers. The antler arrangement thus yields 144,000, confirming the efficacy of measuring the angle between the pin end-stops.

Moreover, when the pin is swung backwards, to facilitate the measurement of the angle of 144° from each pin end-stop position, we notice that the pin (which resembles a sword, plate 20b) moves, naturally, away from the [largest] stone fixed either side of the brooch front. This means that—by removing the pin (the sword) from the stone—the angle of 144° can be measured or 'he who draws the sword from the stone—and understands what is happening—becomes one of the 144,000, destined to be a king in Heaven'.

This all sounds familiar. In the Arthurian legend, whoever 'pulled the sword from the stone would become a king on Earth'. Arthur pulled the sword from the stone and became a king on Earth 'who would live again' in Heaven. Which surely means that King Arthur must have decoded the Tara brooch in the same way. The information contained within the Tara brooch must be the foundation that supports the so-called myth contained in the Arthurian legend, which must actually be fact.

The rear of the brooch (plate 20b) is altogether more austere. Figure 45 enables analysis in greater detail. The four profile dragon heads (plate 21h) are on the obverse transformed into bony dragon skeleton heads, forming an immediate association with death. Two black semicircular stones, partially eclipsed by the main ring (figure 45a), show the rise and fall of Venus, but this time only as the 'black' evening star, emphasising darkness and death. The two large circular stones (figure 45b) are made of black glass, inlaid with 6 pieces of red glass [6, and again 6] and altogether there are 6 circular black stones (five circular + two semi-circular), making 666 from the black circular stones on the obverse. The centre of each inlaid stone also embraces an equilateral triangle (666).

The flapping-wing bird indicators on the obverse this time appear only in black, referring to the bird of the night, the bat, and death. Venus appears yet again (figure 45c) in the ring panels (figure 45c) as two tiny white studs in a sea of Celtic swirling blackness.

The flapping-wing bird indicators on the obverse this time appear only in black, referring to the bird of the night, the bat, and death. Venus appears yet again in the ring panels (figure 45c) as two tiny white studs in a sea of Celtic swirling blackness.

The Tara brooch thus represents light and life on the front, for those who understand the super-science of the Sun and the higher orders of spirituality, and darkness and death on the back, for those who do not, revealing the choices between everlasting life or death.

The Tara brooch is not the only large ring brooch, several others have been found in Ireland and Scotland; like the Roscrea Brooch and the Loughmoe brooches of Tipperary, the Kilmainham brooch, the Ardagh Hoard brooches, the Cadboll brooch and the Hunterston brooch of Scotland among them. But the Tara Brooch is the largest, the most spectacular, the most beautiful, the most exquisite and the most ornate and the most sophisticated. It is the only one to carry pin-end stops, on the main pin and on the ring that are capable of making contact with each other. It is the only one to contain the super-science of the Sun and the higher orders of spirituality, it is the only one to feature a stag, a dragon, a snake and a torc (plate 22k), and it is far too large and dangerous to have been worn as a brooch.

The Ardagh Hoard

The Ardagh hoard was found in September 1868 under a stone slab beneath a hawthorn tree in a disused earth fort at Reerasta Rath (near Ardagh, County Limerick, Ireland) by Paddy Flanagan and Jimmy Quinn while digging potatoes for Jimmy's mother who rented around 20 acres of land from Nuns who owned the site. The treasure had been deliberately hidden and concealed at some time in antiquity. It comprised of a magnificent chalice that has since become known as the Ardagh Chalice (plate 23), a smaller undecorated simple copper-alloy chalice and four silver brooches, all said to date, by their style, from around AD 750 for the Ardagh Chalice and to around AD 950 for the brooches.

Two things become clear on inspection of the Ardagh Hoard. The Ardagh Chalice did not belong with the other items found, they had simply all been buried together. Secondly, archaeologists agree that whoever made the Ardagh Chalice must have made the Tara Brooch, because the

The Tara Brooch (rear)

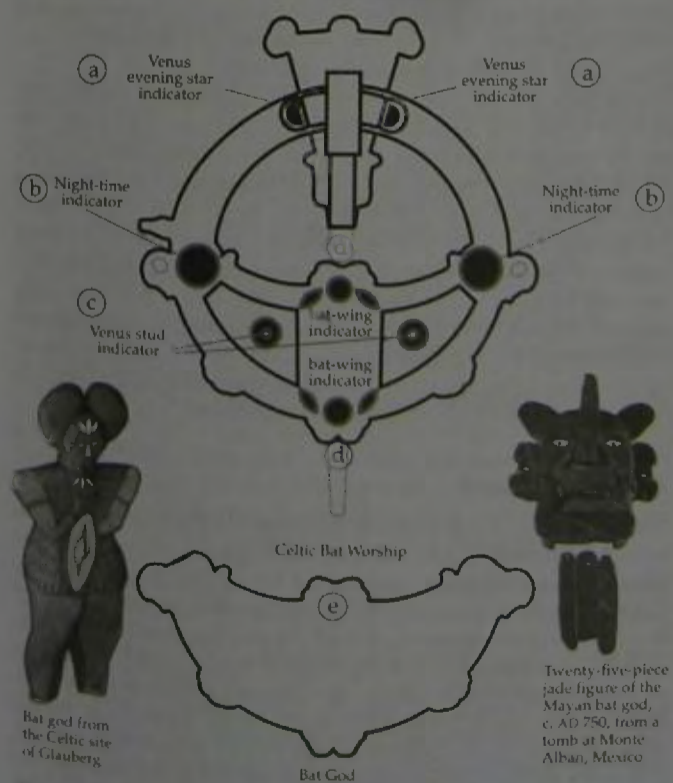

Figure 45. The rear of the Tara brooch is much more austere and sombre than the front. The four profile dragon heads on the front (plate 21h) become bony skeleton heads on the obverse, forming an immediate association with death. (a) The semicircular stones, either side of the pin, represent Venus rising and setting, but now only as the black evening star, in the darkness. The large black and red stones (b) likewise represent Venus as twin black planets and Venus appears yet again (c) as two tiny white studs in a sea of swirling blackness in the ring panels. (d) The brightly coloured flapping-wing indicators on the front now appear on the back in black, representing the wings of the bat, creature of the night, and (e) the outline of the entire brooch now becomes the outline of a bat, representing death. The Tara brooch thus represents light and life on the front and darkness and death on the back, revealing the choices between everlasting life, for those who understand the super-science of the Sun and the higher orders of spirituality, and death, for those who do not.

The Tara Brooch (rear)

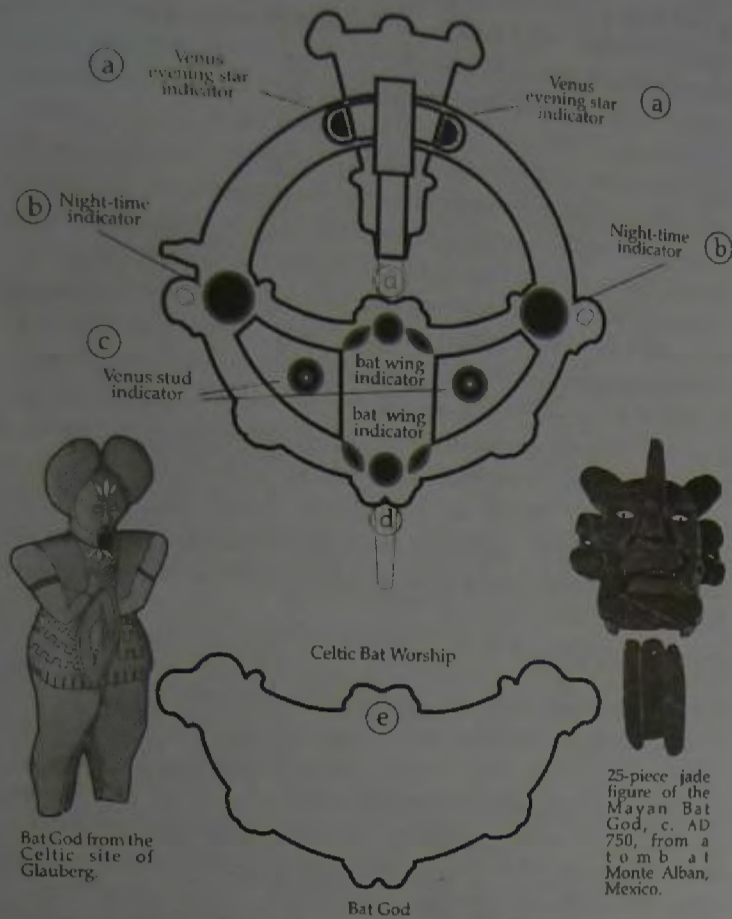

Figure 45. The rear of the Tara brooch is much more austere and sombre than the front. The four profile dragon heads on the front (plate 21h) become bony skeleton-heads on the obverse, forming an immediate association with death. The semicircular stones, either side of the pin, represent Venus rising and setting, but now only as the black evening star, in the darkness. The large black and red stones (b) likewise represent Venus as twin black planets and Venus appears yet again (c) as two tiny white studs in a sea of swirling blackness in the panels. The brightly coloured flapping-wing indicators on the front now appear on the back in black, representing the wings of the bat, creature of the night and the outline of the entire brooch now becomes the outline of a bat, representing death. The Tara brooch thus represents light and life on the front, and darkness and death on the back, revealing the choices between everlasting life, for those who understand the super-science of the Sun and the higher orders of spirituality, or death, for those who do not.

A LAND WITHOUT A KING

the crown chakra (the pineal gland) of the antler arrangement to the vertical centre-line of the antler arrangement measures 14.4° . The antler appendages terminate in double zeros and in between these lies a semicircle (like the setting Sun) shared by both antlers. The antler arrangement thus yields 144,000, confirming the efficacy of measuring the angle between the pin end-stops.

Moreover, when the pin is swung backwards, to facilitate the measurement of the angle of 144° from each pin end-stop position, we notice that the pin (which resembles a sword, plate 20b) moves, naturally, away from the [largest] stone fixed either side of the brooch front. This means that—by removing the pin (the sword) from the stone—the angle of 144° can be measured or 'he who draws the sword from the stone—and understands what is happening—becomes one of the 144,000, destined to be a king in Heaven'.

This all sounds familiar. In the Arthurian legend, whoever 'pulled the sword from the stone would become a king on Earth'. Arthur pulled the sword from the stone and became a king on Earth 'who would live again' in Heaven. Which surely means that King Arthur must have decoded the Tara brooch in the same way. The information contained within the Tara brooch must be the foundation that supports the so-called myth contained in the Arthurian legend, which must actually be fact.

The rear of the brooch (plate 20b) is altogether more austere. Figure 45 enables analysis in greater detail. The four profile dragon heads (plate 21h) are on the obverse transformed into bony dragon skeleton heads, forming an immediate association with death. Two black semicircular stones, partially eclipsed by the main ring (figure 45a), show the rise and fall of Venus, but this time only as the 'black' evening star, emphasising darkness and death. The two large circular stones (figure 45b) are made of black glass, inlaid with 6 pieces of red glass [6, and again 6] and altogether there are 6 circular black stones (five circular + two semicircular), making 666 from the black circular stones on the obverse. The centre of each inlaid stone also embraces an equilateral triangle (666).

The flapping-wing bird indicators on the obverse this time appear only in black, referring to the bird of the night, the bat, and death. Venus appears yet again (figure 45c) in the ring panels (figure 45c) as two tiny white studs in a sea of Celtic swirling blackness.

style, metalwork, design, craftsmanship and sophistication are unparalleled in Celtic artistic achievement elsewhere. This means that the Tara Brooch and the Ardagh Chalice were once kept together and must have become separated.

A quick glance at the chalice is revealing:

There are 12 stud mounts in the girdle that runs beneath the rim of the main bowl but only 11 studs, suggesting that one is missing. The 11 enamelled studs (plate 23a) are similar in style to the enamelled stud on the Basse Yutz flagons (plate 14) which archaeologists date at around 400 BC.

The name of an Apostle has been crudely engraved—as though with the tip of a large nail—beneath each of the stud mounts; a strange thing to do given the quality of workmanship in the rest of the piece.

The name of Judas Iscariot, who betrayed Jesus, is missing.

The name of Mathius, who replaced Judas, is also missing.

The name of St Paul, who was not at the Last Supper, appears as one of the 12 names.

The dating of the Chalice was agreed at around AD 750 because the style is identical to the Tara brooch and because the names of the Apostles have been carved in insular majuscule script—the very same script used in the Lindisfarne Gospels (plate 16) meaning, say archaeologists, that the Chalice must date from the same period (AD 698). [But this need not be the case, as we shall see].

And the chalice, like the Tara Brooch, contains an unusually large amount of esoteric information;

Two large solar-crosses dominate the main bowl—immediately associating the piece with the super-science of the Sun.

The pattern of name-carving continues around the chalice running into a Celtic knot-work continuous-line pattern beneath each solar cross, and onwards, to carvings of two dragonheads, one either side of the chalice beneath each of the handle escutcheons—and the dragon represents the feathered snake, a Supergod.

An unusual interlaced maze-like pattern [identical to one found on the Hallsatt scabbard (figure 4)—dating back to 600 BC—and

The Tara Brooch (rear)

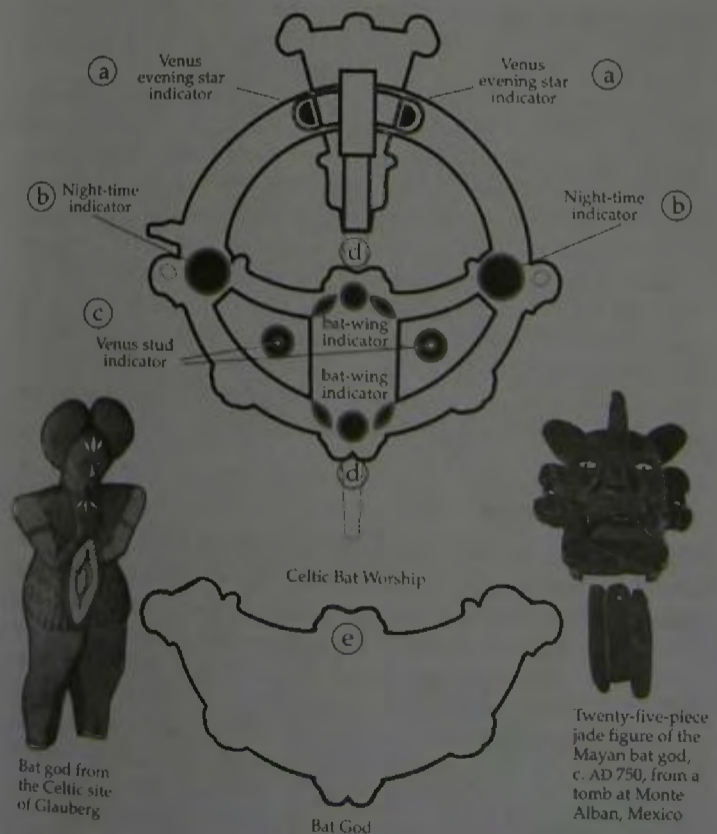

Figure 45. The rear of the Tara brooch is much more austere and sombre than the front. The four profile dragon heads on the front (plate 21h) become bony skeleton heads on the obverse, forming an immediate association with death. (a) The semicircular stones, either side of the pin, represent Venus rising and setting, but now only as the black evening star, in the darkness. The large black and red stones (b) likewise represent Venus as twin black planets and Venus appears yet again (c) as two tiny white studs in a sea of swirling blackness in the panels. (d) The brightly coloured flapping-wing indicators on the front now appear on the back in black, representing the wings of the bat, creature of the night, and (e) the outline of the entire brooch now becomes the outline of a bat, representing death. The Tara brooch thus represents light and life on the front and darkness and death on the back, revealing the choices between everlasting life, for those who understand the super-science of the Sun and the higher orders of spirituality, and death, for those who do not.

identical to another, one that circumscribes the head of Viracocha (figure A6f)—dating back to AD 500] circumscribes the base of the chalice.

Beneath the base a large quartz crystal (which, as we will see later, is synonymous with light) dominates the design and sits underneath, in the dark.

Decorative glass studs in the foot of the chalice are arranged as a pentagon and octagon—known freemason symbols.

We know that the Tara brooch is intimately associated with the Arthurian legend. We know that the Arthurian legend is associated with the Holy Grail, used by Christ at the Last Supper. And we know that that the Tara Brooch and the Ardagh Chalice were once kept together.

Take another look at the Grail legend illustration, plate 19;

In the illustration King Arthur pulls the sword from the stone—at the same time as he worships the Holy Grail at the Round Table—the illustration shows them together, in the same place at the same time.

In the illustration the Grail radiates light—and the Ardagh Chalice (as we shall see shortly) radiates light (from the quartz crystal in the foot-cone).

In the illustration the Grail is flanked on either side by two dragon-angels, and two dragons are engraved on the chalice, either side of the main bowl.

And the names of the Apostles, the followers of Christ, are engraved around the bowl. Surely, the inference is obvious? The so-called Ardagh Chalice *must* be the Holy Grail used by Christ at the Last Supper.

We need to examine the chalice carefully, to confirm the hypothesis.

CHAPTER FIVE

The Holy Grail

The Ardagh Chalice

It seems that Paddy Flanagan found the Ardagh hoard but Jimmy Quinn wanted to take all of the credit for the discovery. The dispute caused the two to fall-out forcing Paddy Flanagan to quit Mrs Quinn's employment. Soon after he died, impoverished, and was laid to rest in a pauper's grave in Newcastlewest. Jimmy Quinn fared no better; he died after emigrating to Australia where he was buried. Mrs Quinn sold the hoard to the Bishop of Limerick, Dr Butler, for £50. Butler examined the chalice with the antiquarian Lord Dunraven before selling it on to the Royal Irish Academy for £500 in 1873.

More than a hundred years later the Irish Academy published *The Treasures of Ireland* and noted;

The Chalice...is...a form well known from Byzantine silver hoards...it is inspired by eastern Mediterranean prototypes...the ultimate La Tène style [La Tène III, 150–50BC] is well represented (*The Treasures of Ireland*, p124, Royal Irish Academy, 1983).

And, according to *The Treasures of the National Museum of Ireland*;

The Ardagh Chalice is quite unlike other European chalices of the early mediaeval period...its closest companions are in fact, to be found

A LAND WITHOUT A KING

The Tara brooch thus represents light and life on the front, for those who understand the super-science of the Sun and the higher orders of spirituality, and darkness and death on the back, for those who do not, revealing the choices between everlasting life or death.

The Tara brooch is not the only large ring brooch; several others have been found in Ireland and Scotland, like the Roscrea brooch and the Loughmoe brooches of Tipperary, the Kilmainham brooch, the Ardagh hoard brooches, the Cadboll brooch and the Hunterston brooch of Scotland among them. But the Tara brooch is the largest, the most spectacular, the most beautiful, the most exquisite, the most ornate and the most sophisticated. It is the only one to carry pin end-stops, on the main pin and on the ring, that are capable of making contact with each other. It is the only one to contain the super-science of the Sun and the higher orders of spirituality; it is the only one to feature a stag, a dragon, a snake and a torc (plate 22k), and it is far too large and dangerous to have been worn as a brooch.

The Ardagh Hoard

The Ardagh hoard was found in September 1868 under a stone slab beneath a hawthorn tree in a disused earth-fort at Reerasta Rath (near Ardagh, County Limerick, Ireland) by Paddy Flanagan and Jimmy Quinn while digging potatoes for Jimmy's mother, who rented twenty acres of land from nuns who owned the site. The treasure had been deliberately hidden and concealed at some time in antiquity. It consisted of a magnificent chalice that has since become known as the Ardagh Chalice (plate 23), a smaller undecorated simple copper-alloy chalice and four silver brooches, all said to date, by their style, from around AD 750 for the Ardagh Chalice and to around AD 950 for the brooches.

Two things become clear on inspection of the Ardagh hoard. The Ardagh Chalice did not belong with the other items found; they had simply all been buried together. Secondly, archaeologists agree that whoever made the Ardagh Chalice *must have made the Tara brooch*, because the style, metalwork, design, craftsmanship and sophistication are unparalleled in Celtic artistic achievement elsewhere. This means that the Tara brooch and the Ardagh Chalice were once kept together and must have become separated.

A LAND WITHOUT A KING

A quick glance at the chalice is revealing:

- There are twelve stud mounts in the girdle that runs beneath the rim of the main bowl but only eleven studs, suggesting that one is missing. The eleven enamelled studs (plate 23a) are similar in style to the enamelled stud on the Basse Yutz flagons (plate 14), which archaeologists date around 400 BC.
- The name of an Apostle has been crudely engraved—as though with the tip of a large nail—beneath each of the stud mounts, a strange thing to do given the quality of workmanship in the rest of the piece.
- The name of Judas Iscariot, who betrayed Jesus, is missing.
- The name of Mathius, who replaced Judas, is also missing.
- The name of St. Paul, who was not at the Last Supper, appears as one of the twelve names.
- The dating of the chalice was agreed at around AD 750 because the style is identical to the Tara brooch and because the names of the Apostles have been carved in insular majuscule script, the very same script used in the Lindisfarne Gospels (plate 16)—meaning, say archaeologists, that the chalice *must* date from the same period (AD 698). [But this need not be the case, as we shall see].

And the chalice, like the Tara brooch, contains an unusually large amount of esoteric information:

- Two large solar crosses dominate the main bowl—immediately associating the piece with the super-science of the Sun.
- The pattern of name carving continues around the chalice, running into a Celtic knot-work continuous-line pattern beneath each solar cross and onwards, to carvings of two dragon heads, one either side of the chalice beneath each of the handle escutcheons—and the dragon represents the feathered snake, a Supergod.
- An unusual interlaced maze-like pattern [identical to one found on the Hallsatt scabbard (figure 4)—dating back to 600 BC—and identical to another, one that circumscribes the head of Viracocha (figure A6f)—dating back to AD 500] circumscribes the base of the chalice.
- Beneath the base a large quartz crystal (which, as we shall see later,

Identical to another, one that circumscribes the head of Viracocha (figure A6f)—dating back to AD 500] circumscribes the base of the chalice.

Beneath the base a large quartz crystal (which, as we will see later, is synonymous with light) dominates the design and sits underneath, in the dark.

Decorative glass studs in the foot of the chalice are arranged as a pentagon and octagon—known freemason symbols.

We know that the Tara brooch is intimately associated with the Arthurian legend. We know that the Arthurian legend is associated with the Holy Grail, used by Christ at the Last Supper. And we know that that the Tara Brooch and the Ardagh Chalice were once kept together.

Take another look at the Grail legend illustration, plate 19:

- In the illustration King Arthur pulls the sword from the stone—at the same time as he worships the Holy Grail at the Round Table—the illustration shows them together, in the same place at the same time.

- In the illustration the Grail radiates light—and the Ardagh Chalice (as we shall see shortly) radiates light (from the quartz crystal in the foot-cone).

- In the illustration the Grail is flanked on either side by two dragon-angels, and two dragons are engraved on the chalice, either side of the main bowl.

And the names of the Apostles, the followers of Christ, are engraved around the bowl. Surely, the inference is obvious? The so-called Ardagh Chalice *must* be the Holy Grail used by Christ at the Last Supper.

We need to examine the chalice carefully, to confirm the hypothesis.

CHAPTER FIVE

The Holy Grail

The Ardagh Chalice

It seems that Paddy Flanagan found the Ardagh hoard but Jimmy Quinn wanted to take all of the credit for the discovery. The dispute caused the two to fall-out forcing Paddy Flanagan to quit Mrs Quinn's employment. Soon after he died, impoverished, and was laid to rest in a pauper's grave in Newcastlewest. Jimmy Quinn fared no better; he died after emigrating to Australia where he was buried. Mrs Quinn sold the hoard to the Bishop of Limerick, Dr Butler, for £50. Butler examined the chalice with the antiquarian Lord Dunraven before selling it on to the Royal Irish Academy for £500 in 1873.

More than a hundred years later the Irish Academy published *The Treasures of Ireland* and noted:

The Chalice... is... a form well known from Byzantine silver hoards... it is inspired by eastern Mediterranean prototypes... the ultimate La Tène style [La Tène III, 150–50BC] is well represented (*The Treasures of Ireland*, p124, Royal Irish Academy, 1983).

And, according to *The Treasures of the National Museum of Ireland*:

The Ardagh Chalice is quite unlike other European chalices of the early mediaeval period... its closest companions are in fact, to be found

A LAND WITHOUT A KING

is synonymous with light) dominates the design and sits underneath, in the dark.

- Decorative glass studs in the foot of the chalice are arranged as a pentagon and an octagon—known Freemason symbols.

We know that the Tara brooch is intimately associated with the Arthurian legend. We know that the Arthurian legend is associated with the Holy Grail, used by Christ at the Last Supper. And we know that the Tara brooch and the Ardagh Chalice were once kept together.

Take another look at the Grail legend illustration, plate 19:

- In the illustration King Arthur pulls the sword from the stone, at the same time as he worships the Holy Grail at the Round Table—the illustration shows them together, in the same place at the same time.

- In the illustration the Grail radiates light—and the Ardagh Chalice (as we shall see shortly) radiates light (from the quartz crystal in the foot-cone).

- In the illustration the Grail is flanked by two dragon-angels and two dragons are engraved on the chalice, either side of the main bowl.

And the names of the Apostles, the followers of Christ, are engraved around the bowl. Surely, the inference is obvious. The so-called Ardagh Chalice *must* be the Holy Grail used by Christ at the Last Supper.

We need to examine the chalice carefully, to confirm the hypothesis.

CHAPTER FIVE

The Holy Grail

The Ardagh Chalice

It seems that Paddy Flanagan found the Ardagh hoard but Jimmy Quinn wanted to take all of the credit for the discovery. The dispute caused the two to fall out, forcing Paddy Flanagan to quit Mrs Quinn's employment. Soon after, he died, impoverished, and was laid to rest in a pauper's grave in Newcastlewest. Jimmy Quinn fared no better; he died after emigrating to Australia, where he was buried. Mrs Quinn sold the hoard to the bishop of Limerick, Dr Butler, for fifty pounds. Butler examined the chalice with the antiquarian Lord Dunraven before selling it to the Royal Irish Academy for £500 in 1873.

More than a hundred years later, the Irish Academy published *The Treasures of Ireland* and noted:

The Chalice... is... a form well known from Byzantine silver hoards... it is inspired by eastern Mediterranean prototypes... the ultimate La Tène style [La Tène III, 150–50 BC] is well represented. (*The Treasures of Ireland*, p. 124, Royal Irish Academy, 1983)

And, according to *The Treasures of the National Museum of Ireland*:

The Ardagh Chalice is quite unlike other European chalices of the early mediaeval period... its closest companions are in fact, to be found among Byzantine chalices of the Eastern Church. (*The Treasures of the National Museum of Ireland*, p. 178, Gill and Macmillan, 2002)

among Byzantine chalices of the Eastern Church (*The Treasures of the National Museum of Ireland*, p178, Gill and Macmillan, 2002).

The Irish claim jurisdiction for the writing of the Book of Kells, although the consensus today prefers that it was written at Iona. It is understandable that they should wish to claim jurisdiction over the manufacture of the Chalice, given its beauty, the quality and the craftsmanship evident in the piece. And, after all, the experts say, the carving of the names of the Apostles uses the very same insular majuscule script found in the Lindisfarne Gospels, which means that it *must* date to AD 698. Of course, they have no idea that the person who engraved it was different to the one who manufactured it. And they have no idea that the appearance of the Chalice inspired a whole new generation of inferior look-alikes. So there's no harm in describing the chalice as it actually appears, they have nothing to lose, because it *has* to date to AD 698. It's easy to see why they believe what they want to, despite the evidence;

- The La Tène style [150 BC–50 BC] is well represented; in other words, it seems to date from around 150–50 BC.
- It is influenced by the Byzantine style [AD 350+]—which itself was influenced by the earlier La Tène style [150–50 BC].
- It is inspired by eastern Mediterranean prototypes; meaning that it was probably made in the eastern Mediterranean.
- It is quite unlike other European chalices of the early mediaeval period; meaning that it is unlikely to be European.

Whether the Irish will prefer to deny that they now hold the Holy Grail, the most precious, the most treasured, the most sought-after liturgical relic of the Christian Church, in their own collection at the National Museum of Ireland, remains to be seen.

Construction of the Grail

The Irish Academy passed the chalice to a jeweller named Johnson who took it apart for cleaning and re-examination. Johnson's findings were incorporated into a report, written by Dunraven in the 1874 *Transactions of the Irish Academy*. The two investigators reached the conclusion that there are 354 separate parts to the chalice and that the bowl, stem and foot-cone were held together by a single iron bolt attached to the bowl.

The last Druidic calendar known to have been used (Chapter 1) is the one found at Coligny near Bourg-en-Bresse in France dating from the reign of Augustus (63 BC–AD 14). That was the last time, as far as we know, that the Druidic year of 354 days was used (although it might have been used by the Druids who defied the Romans at Ybys Mon until as late as AD 70). If the Chalice was made by Christian monks during the Lindisfarne period, as archaeologists suppose, then why encode the ancient calendar of pagan Druids into the arrangement? Why not encode the 365.25-day figure used by the Lindisfarne monks at the time?

In 1961 the Chalice had become loose at the stem and was sent to the research laboratory at the British Museum, in London, for repair and restoration. The anticipated restoration encountered many problems, not least of which was the re-organisation of the British Museum that entailed shifting departments between different buildings during the period the chalice was there, and the whole job took much longer than expected. At one point it was hurriedly re-assembled, placed in an exhibition, in 1962, and then taken apart again for the restoration job to continue.

In 1970 the Museum of Fine Arts, in Boston, U.S.A.—intending to demonstrate how modern scientific techniques could be used to study ancient archaeological artefacts—scoured museum inventories around the world for a suitable example to investigate. As fate would have it they chose the Ardagh Chalice and in 1970 produced a paper *Application of Science in Examination of Works of Art*, edited by William J. Young.

The objectives of the scientific investigation were, firstly, to find a way of permanently re-securing the loose neck (also referred to as the 'stem'). Secondly, to check Dunraven's account for reliability and to confirm his finding that 'a square iron bolt' held the bowl, stem and foot-cone together and, thirdly, to determine the nature of the various materials employed. The final objective was to collate results into a published format. As much evidence as possible was to be recorded photographically and by scaled drawings, whether it was currently understood or not, to facilitate future investigation.

It was agreed that the investigation would progress through various stages: the study and documentation of the chalice as it was received; disassembly of the chalice and the measurement, recording and clean-

The Irish claim jurisdiction for the writing of the Book of Kells, although the consensus today prefers that it was written at Iona. It is understandable that they should want to claim jurisdiction over the manufacture of the chalice, given its beauty, the quality and the craftsmanship evident in the piece. And, after all, the experts say, the carving of the names of the Apostles uses the very same insular majuscule script found in the Lindisfarne Gospels, which means that it *must* date to AD 698. Of course, they have no idea that the person who engraved it was different from the one who manufactured it. And they have no idea that the appearance of the chalice inspired a whole new generation of inferior look-alikes. So there's no harm in describing the chalice as it actually appears; they have nothing to lose, because it *has* to date to AD 698. It's easy to see why they believe what they want to, despite the evidence:

- The La Tène style [150 BC–50 BC] is well represented; in other words, it seems to date from around 150–50 BC.
- It is influenced by the Byzantine style [AD 350+]—which itself was influenced by the earlier La Tène style [150–50 BC].
- It is inspired by eastern Mediterranean prototypes, meaning that it was probably made in the eastern Mediterranean.
- It is quite unlike other European chalices of the early mediaeval period, meaning that it is unlikely to be European.

Whether the Irish will prefer to deny that they now hold the Holy Grail, the most precious, the most treasured, the most sought-after liturgical relic of the Christian Church, in their own collection at the National Museum of Ireland, remains to be seen.

Construction of the Grail

The Irish Academy passed the chalice to a jeweller named Johnson, who took it apart for cleaning and re-examination. Johnson's findings were incorporated into a report, written by Dunraven in the 1874 *Transactions of the Irish Academy*. The two investigators reached the conclusion that there are 354 separate parts to the chalice and that the bowl, stem and foot-cone were held together by a single iron bolt attached to the bowl.

The last Druidic calendar known to have been used (chapter 1) is the one found at Coligny near Bourg-en-Bresse in France dating from the reign of Augustus (63 BC–AD 14). That was the last time, as far as we know, that the Druidic year of 354 days was used (although it might have been used by the Druids who defied the Romans at Ybys Mon until as late as AD 70). If the chalice was made by Christian monks during the Lindisfarne period, as archaeologists suppose, then why encode the ancient calendar of pagan Druids into the arrangement? Why not encode the 365.25-day figure used by the Lindisfarne monks at the time?

In 1961 the chalice had become loose at the stem and was sent to the research laboratory at the British Museum, in London, for repair and restoration. The anticipated restoration encountered many problems, not least of which was the re-organisation of the British Museum, which entailed shifting departments between different buildings during the period the chalice was there, and the whole job took much longer than expected. At one point it was hurriedly re-assembled, placed in an exhibition, in 1962, and then taken apart again for the restoration job to continue.

In 1970 the Museum of Fine Arts, in Boston—intending to demonstrate how modern scientific techniques could be used to study ancient archaeological artefacts—scoured museum inventories around the world for a suitable example to investigate. As fate would have it, they chose the Ardagh Chalice and in 1970 produced a paper called *Application of Science in Examination of Works of Art*, edited by William J. Young.

The objectives of the scientific investigation were, firstly, to find a way of permanently re-securing the loose neck (also referred to as the 'stem'); secondly, to check Dunraven's account for reliability and to confirm his finding that 'a square iron bolt' held the bowl, stem and foot-cone together; and, thirdly, to determine the nature of the various materials employed. The final objective was to collate results into a published format. As much evidence as possible was to be recorded photographically and by scaled drawings, whether it was currently understood or not, to facilitate future investigation.

It was agreed that the investigation would progress through various stages: the study and documentation of the chalice as it was received; disassembly of the chalice and the measurement, recording

ing of individual components; assimilation of observations and resulting deductions; hypothecation, in regard to a theory to adequately explain the chalice and re-assembly and, finally, re-examination of the entire piece to confirm the theory.

The methods used to study the chalice included observation, through touch; measurement by a scale; callipers, slide gauge, micrometer, micrometer eye-piece (in a microscope) and by travelling microscope; direct visual observation and microscope assisted observation through air, oil-films and immersion in liquids. Indirect observations using moulds, wax impressions, silhouettes, shadows cast by straight edges and by grids of lines. Detailed comparisons were made visually by superimposition of negative images from one component on positive images of another component or by use of a synchroniscope—an instrument used by ballistic experts for comparing marks on bullets. Non-destructive tests were carried out to determine metallic content and hardness; observations were made on naturally etched surfaces, and on prepared and polished surfaces and samples were analysed using X-ray diffraction analysis and spectrography (the analysis of light emitted from a source). The recording of details was made primarily by photography, using varying types of light, backgrounds and cameras and a Vickers projection microscope, viewing objects directly and also indirectly through mirrors.

General Description

The entire piece (plate 23a) stands (figure 46) 178mm (7 inches) high and measures 185mm (7.3 inches) wide across the outer diameter of the bowl. Two handles, fixed on opposite sides of the bowl, increase the outer width to 230mm (9 inches)—[scaled on the computer from height and width measurements supplied].

The assembly brings together the main silver bowl that carries the [damaged] split-pin fastening bolt (figure 46). The bolt passes through the centre of a stem assembly made of three highly-decorated gold-plated bronze pieces comprising of a tubular stem with a concave washer-type interface collar, that cradles the bowl above, and an identical convex washer-type interface collar that sits on the foot-cone below (shaded in grey in the figure 46 cross-section box).

The Grail—Construction

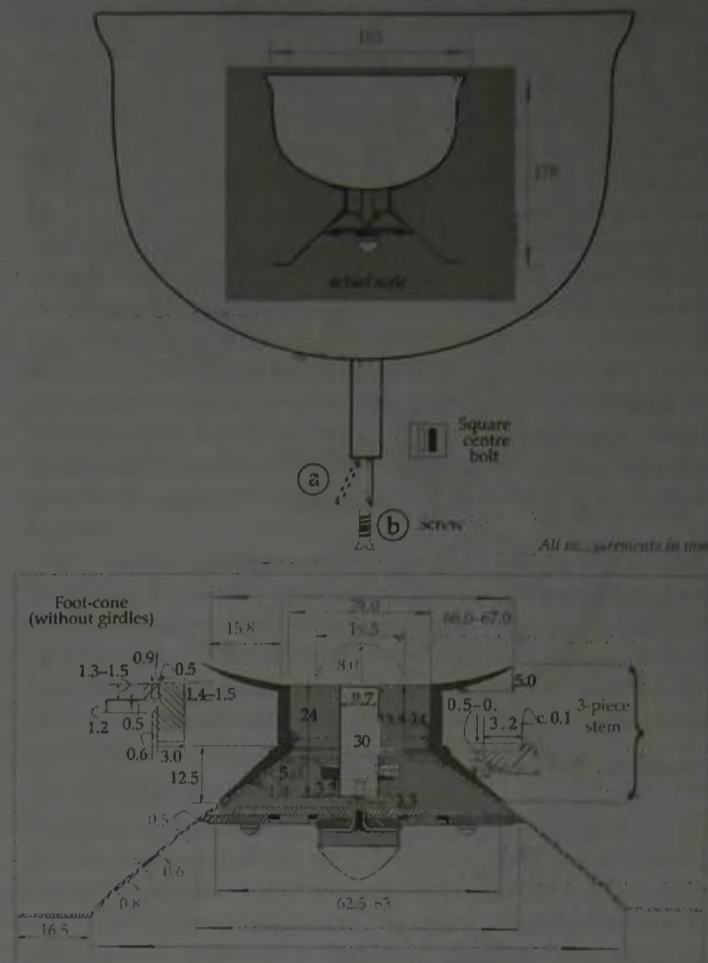

Figure 46. (a) The 354 pieces of the Grail are held together by a square bolt fashioned into a split-pin beneath the base of the bowl—the legs of which were originally spread apart to hold the assembly together. The damaged pin had been modified in the nineteenth-century by the jeweller, Johnson, and again, in 1962, by the British Museum who repaired the worn-out fixing by fitting a screw (b) into the square bolt that carried the pin. The assembled chalice thus relies entirely upon the integrity of the square bolt. The square represents virtue and knowledge for the esotericist.

THE HOLY GRAIL

and cleaning of individual components; assimilation of observations and resulting deductions; hypothecation, in regard to a theory to adequately explain the chalice and re-assembly and, finally, re-examination of the entire piece to confirm the theory.

The methods used to study the chalice included observation, through touch; measurement by a scale, callipers, slide gauge, micrometer, micrometer eyepiece (in a microscope) and travelling microscope; direct visual observation and microscope-assisted observation through air, oil films and immersion in liquids. Indirect observations using moulds, wax impressions, silhouettes, shadows cast by straight-edges and by grids of lines. Detailed comparisons were made visually by superimposition of negative images from one component on positive images of another component or by use of a synchroniscope—an instrument used by ballistic experts for comparing marks on bullets. Non-destructive tests were carried out to determine metallic content and hardness; observations were made on naturally etched surfaces, and on prepared and polished surfaces; and samples were analysed using X-ray diffraction analysis and spectrography (the analysis of light emitted from a source). The recording of details was made primarily by photography, using varying types of light, backgrounds and cameras and a Vickers projection microscope, viewing objects directly and also indirectly through mirrors.

General Description

The entire piece (plate 23a) stands 178 mm (7 inches) high and measures 185 mm (7.3 inches) wide across the outer diameter of the bowl (figure 46). Two handles, fixed on opposite sides of the bowl, increase the outer width to 230 mm (9 inches)—[scaled on the computer from height and width measurements supplied].

The assembly brings together the main silver bowl that carries the [damaged] split-pin fastening bolt (figure 46). The bolt passes through the centre of a stem assembly made of three highly decorated gold-plated bronze pieces consisting of a tubular stem with a concave washer-type interface collar that cradles the bowl above and an identical convex washer-type interface collar that sits on the foot-cone below (shaded in grey in the figure 46 cross-section box).

The Grail—Construction

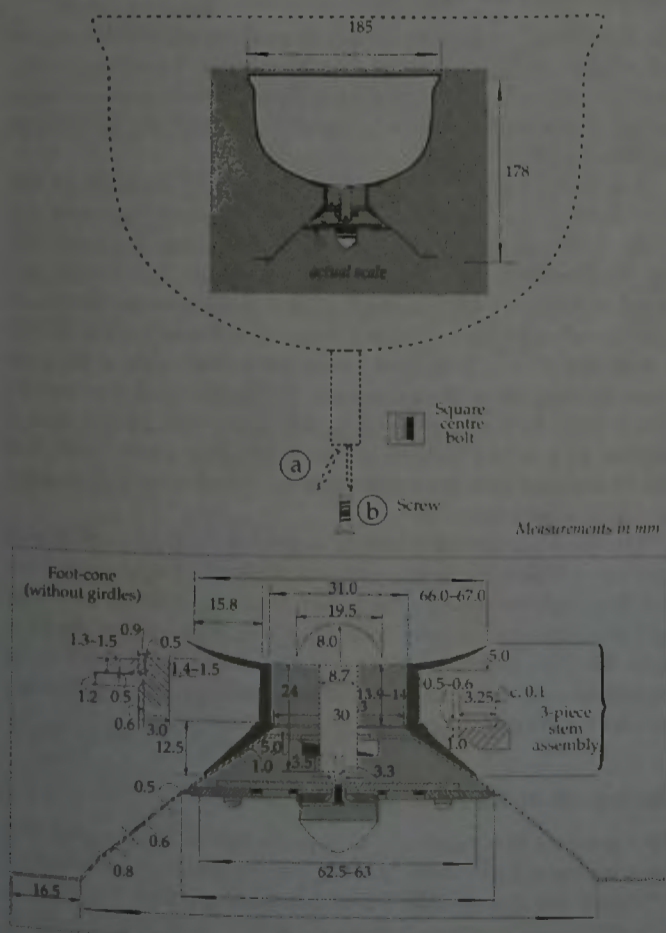

Figure 46. (a) The 354 pieces of the Grail are held together by a square bolt fashioned into a split-pin beneath the base of the bowl—the legs of which were originally spread apart to hold the assembly together. The damaged pin had been modified in the nineteenth century by the jeweller Johnson, and again, in 1962, by the British Museum, who repaired the worn-out fixing by fitting a screw (b) into the square bolt that carried the pin. The assembled chalice thus relies entirely upon the integrity of the square bolt. The square represents virtue and knowledge for the esotericist.

The Grail—Construction

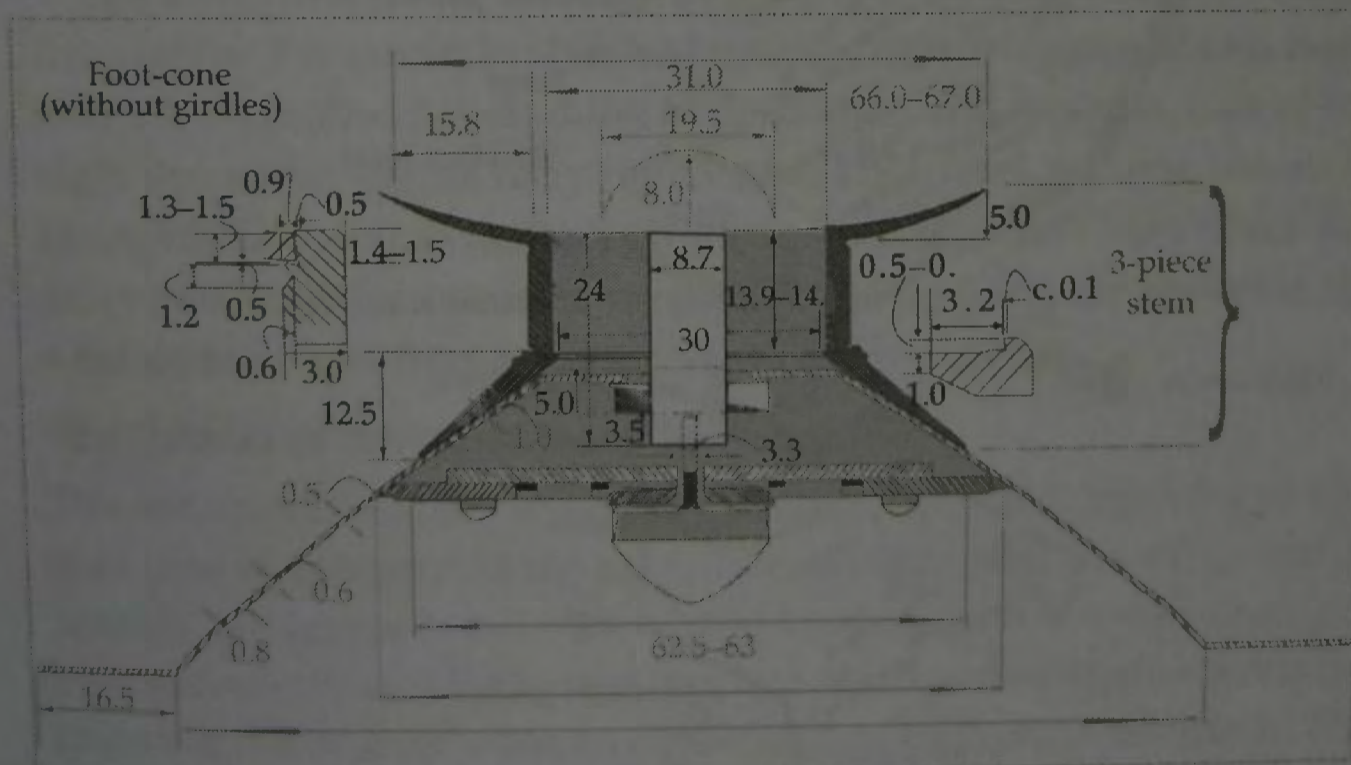
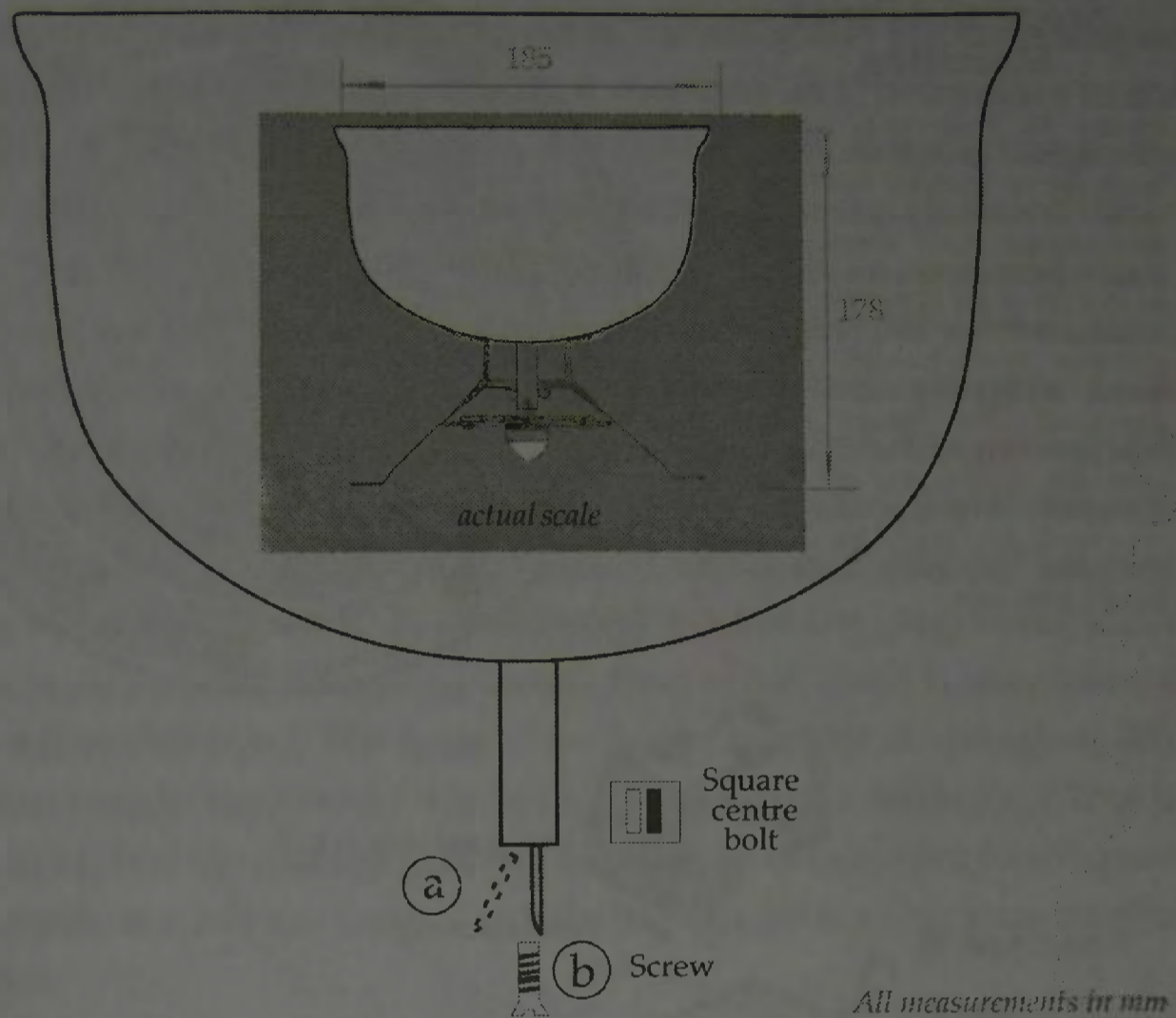

Figure 46. (a) The 354 pieces of the Grail are held together by a square bolt fashioned into a split-pin beneath the base of the bowl—the legs of which were originally spread apart to hold the assembly together. The damaged pin had been modified in the nineteenth-century by the jeweller, Johnson, and again, in 1962, by the British Museum who repaired the worn-out fixing by fitting a screw (b) into the square bolt that carried the pin. The assembled chalice thus relies entirely upon the integrity of the square bolt. The square represents virtue and knowledge for the esotericist.

The Grail—Construction

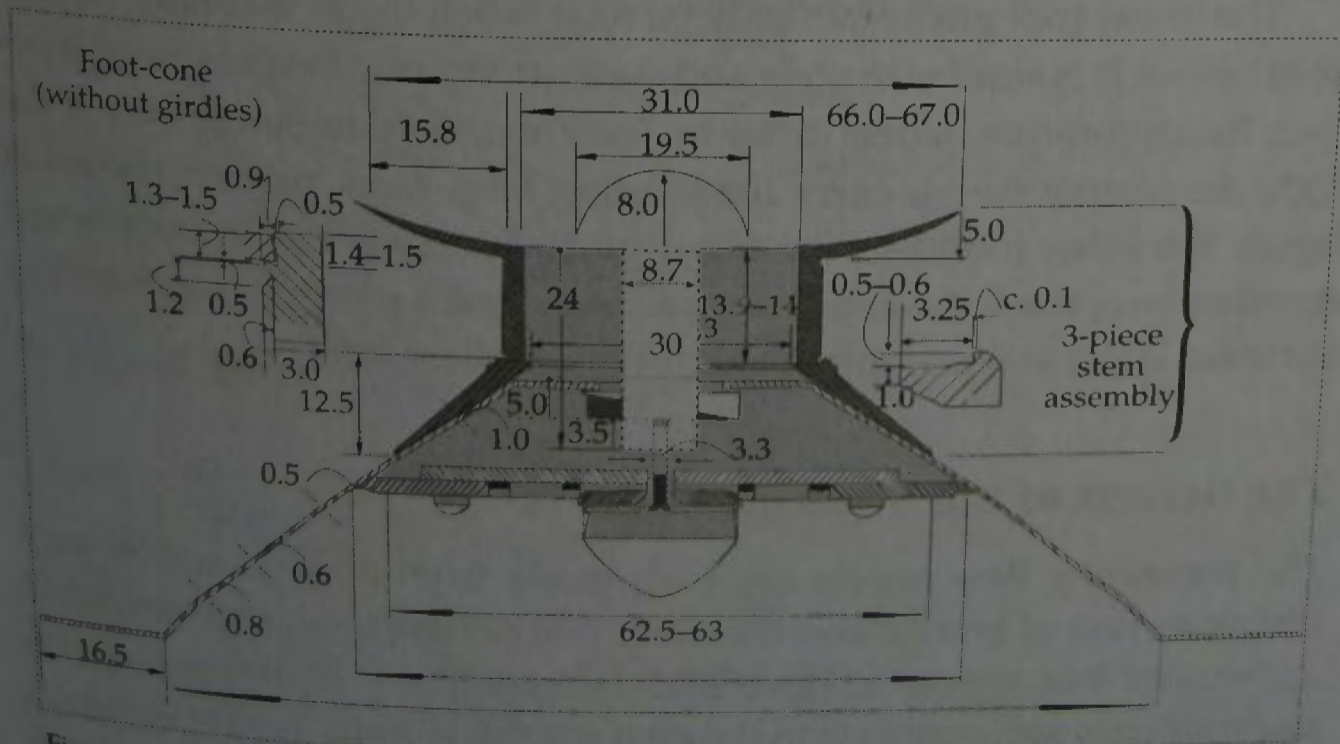
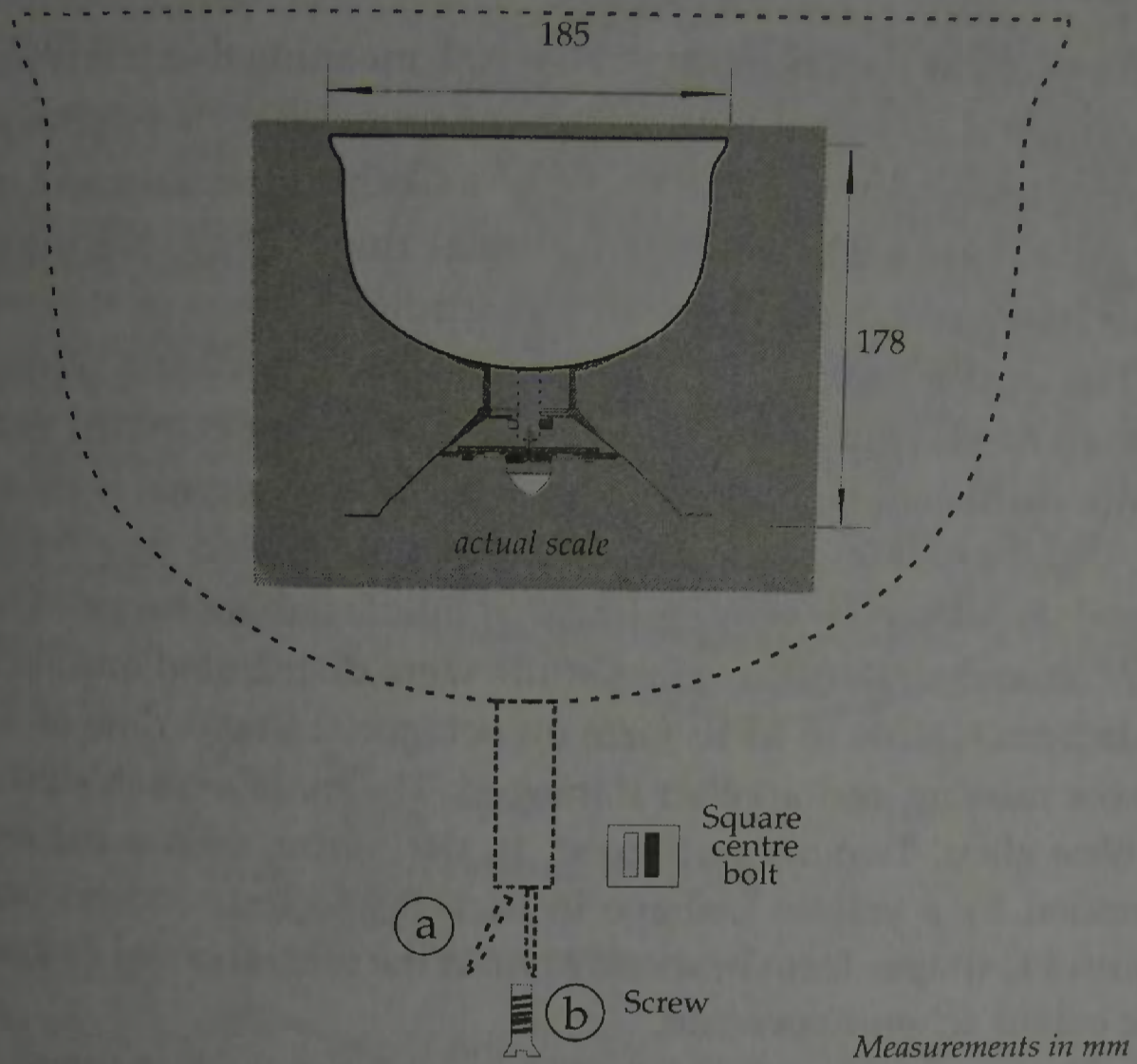

Figure 46. (a) The 354 pieces of the Grail are held together by a square bolt fashioned into a split-pin beneath the base of the bowl—the legs of which were originally spread apart to hold the assembly together. The damaged pin had been modified in the nineteenth century by the jeweller Johnson, and again, in 1962, by the British Museum, who repaired the worn-out fixing by fitting a screw (b) into the square bolt that carried the pin. The assembled chalice thus relies entirely upon the integrity of the square bolt. The square represents virtue and knowledge for the esotericist.

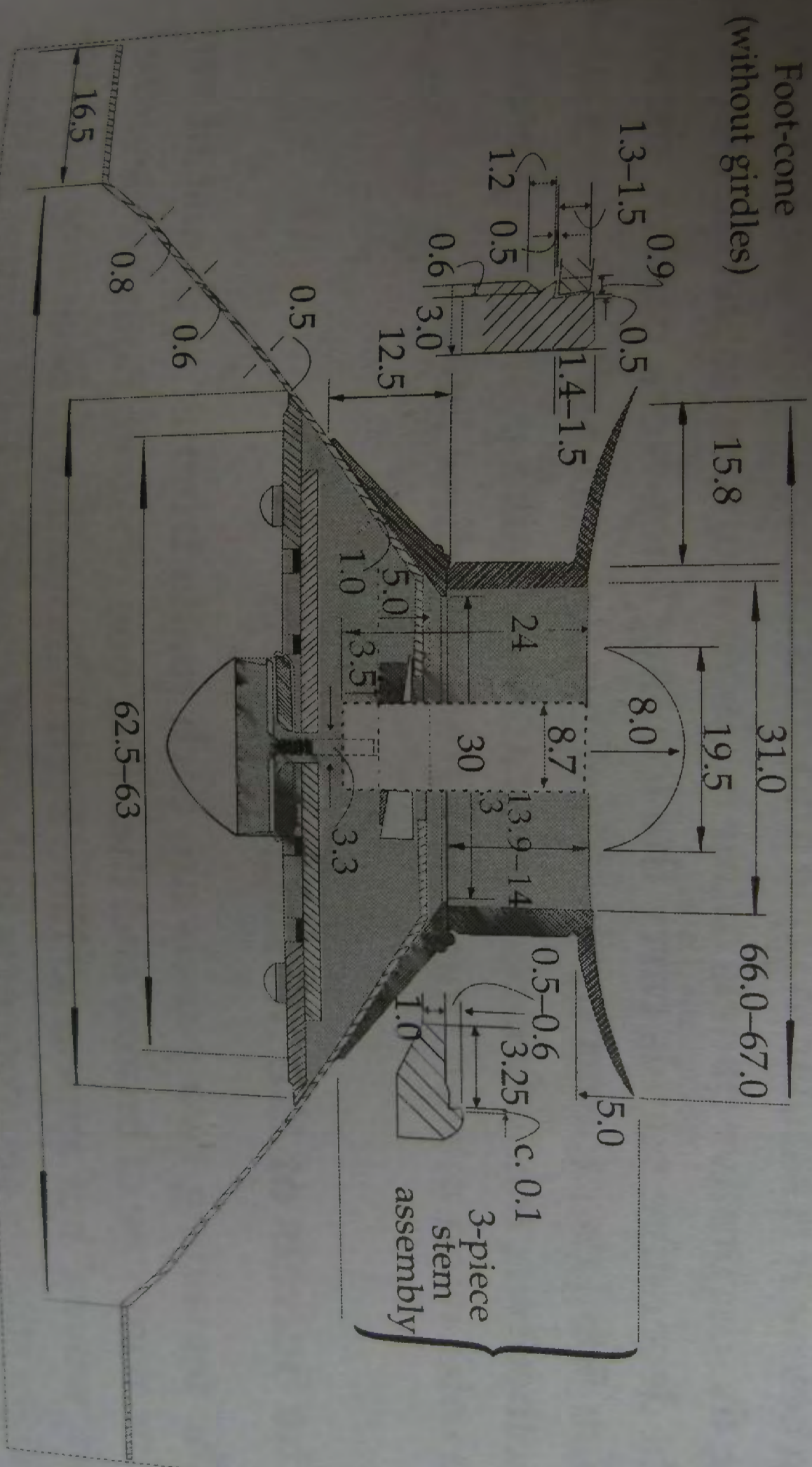

Figure 46. (a) The 354 pieces of the Grail are held together by a square bolt fashioned into a split-pin beneath the base of the bowl—the legs of which were originally spread apart to hold the assembly together. The damaged pin had been modified in the nineteenth century by the jeweller Johnson, and again, in 1962, by the British Museum, who repaired the worn-out fixing by fitting a screw (b) into the square bolt that carried the pin. The assembled chalice thus relies entirely upon the integrity of the square bolt. The square represents virtue and knowledge for the esotericist.

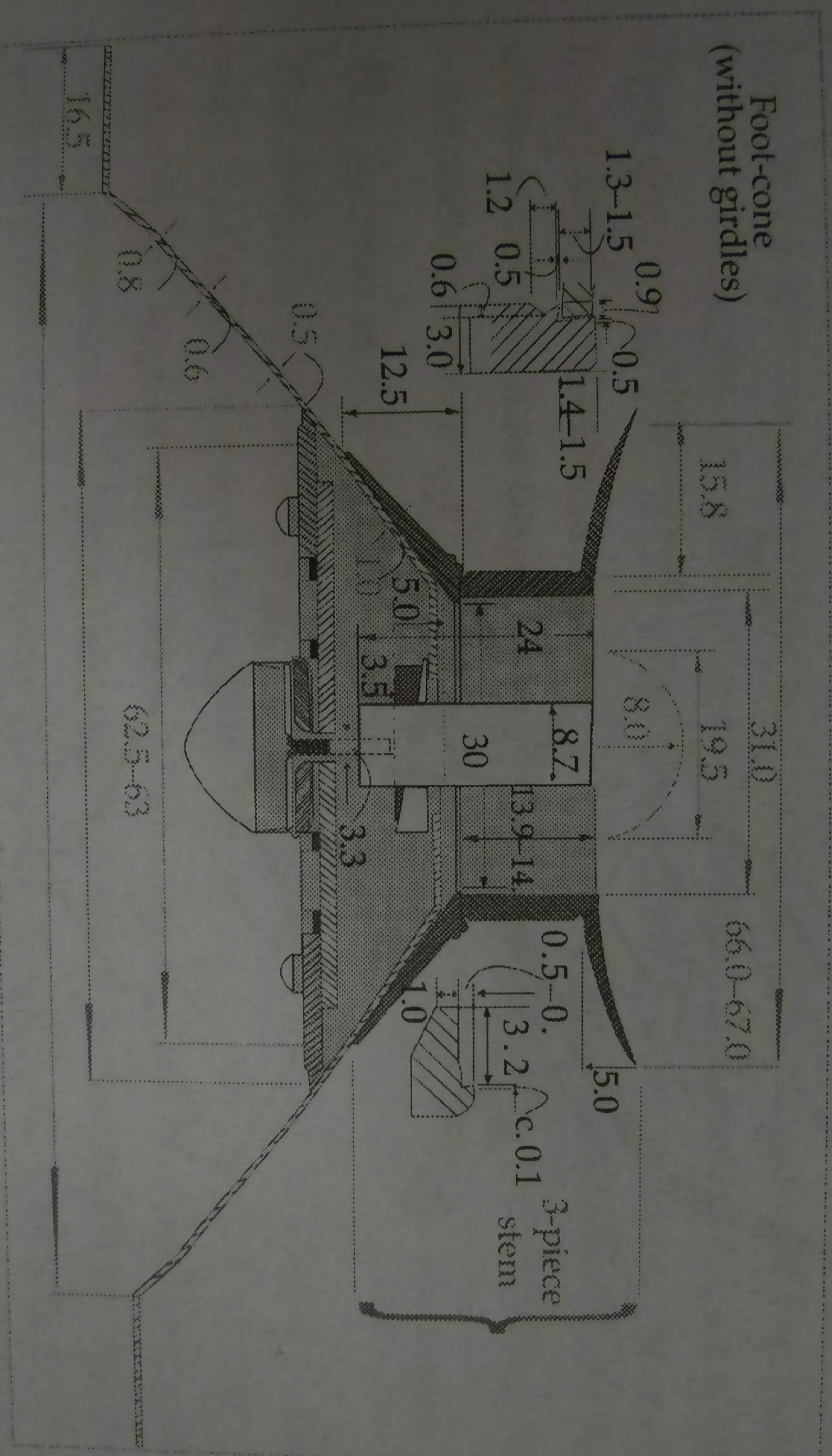
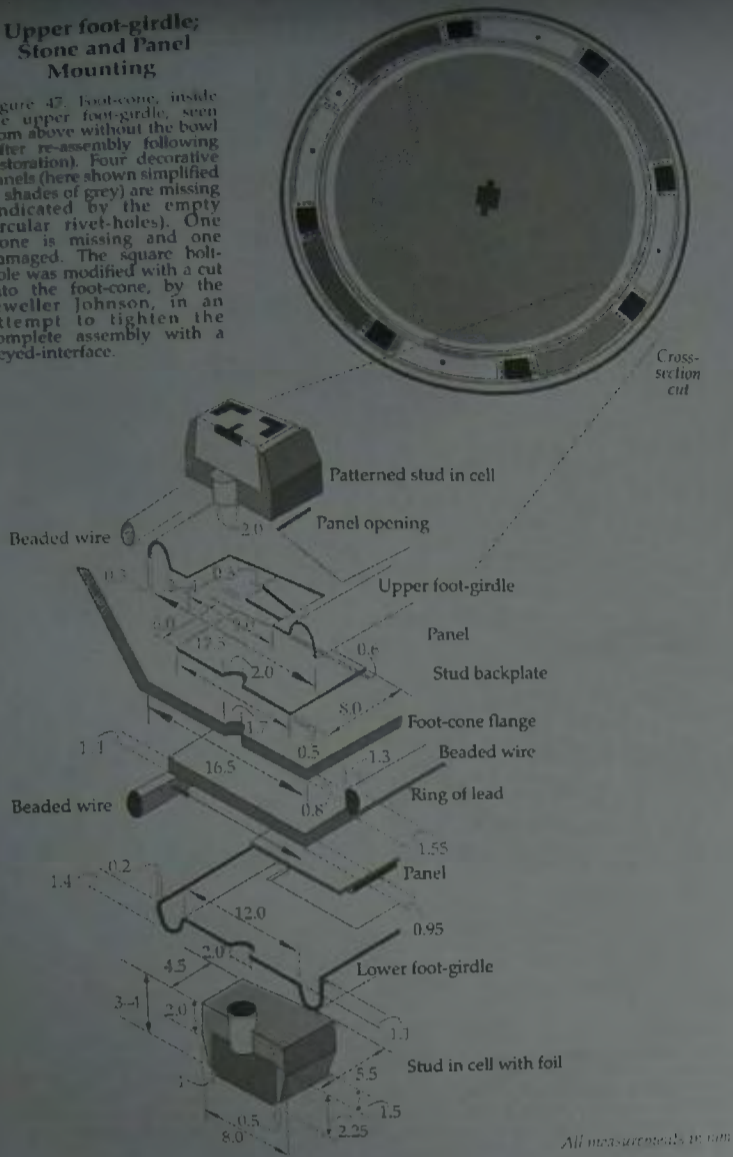

Figure 46. (a) The 354 pieces of the Grail are held together by a square bolt fashioned into a split-pin beneath the base of the bowl—the legs of which were originally spread apart to hold the assembly together. The damaged pin had been modified in the nineteenth-century by the jeweller, Johnson, and again, in 1962, by the British Museum who repaired the worn-out fixing by fitting a screw (b) into the square bolt that carried the pin. The assembled chalice thus relies entirely upon the integrity of the square bolt. The square represents virtue and knowledge for the esotericist.

Upper foot-girdle; Stone and Panel Mounting

Figure 47. Foot-cone, inside the upper foot-girdle, seen from above without the bowl (after re-assembly following restoration). Four decorative panels (here shown simplified in shades of grey) are missing (indicated by the empty circular rivet-holes). One stone is missing and one damaged. The square bolt-hole was modified with a cut into the foot-cone, by the jeweller Johnson, in an attempt to tighten the complete assembly with a keyed-interface.



All measurements in mm

The Secrets of the Foot Cone

The foot-cone is described as subconical, meaning that it is cone-shaped to a certain degree but becomes more rounded as it progresses to the cone tip, terminating in the shape of a Gothic arch. It has a foot flange that is sandwiched between two similar rings (figure 47), the so-called upper foot-girdle and the lower foot-girdle.

The upper foot-girdle (figure 47)—the one visible when viewed from above—originally carried eight miniature decorated panels that fit into dedicated slots in the ring. Four of the original eight are missing. The remaining four are made of gold-plated cast bronze, patterned with sharply-angular [zig-zag] interlaced knot-work. Originally eight almost-square blue glass studs were distributed around the ring in dedicated slots so as to form an octagonal shape. One of the studs is now missing and another damaged. The mass of each stud consists of blue glass. Two are patterned, in the centre, with a red cross surrounded by a yellow L-shape in each of the four corners [such that pairs of L-shapes form square parenthesis around the central cross] and two have the colour-scheme reversed.

The lower foot-girdle can only be seen when the foot-cone is viewed from below. It is similar in style and construction to the one above, however the decorative panels differ in decoration and material: four of the eight decorative panels carry the looping knot-work pattern, shown in figure 50b [also found in the bowl-girdle] and are made from silver. Another two, made from copper, carry swastika patterns, representing the solar wind as seen from Earth (more on these later).

The Secrets of the mesh-mat Panels

The remaining two panels are each made from a mesh-mat of very fine wire, one of bronze and the other one of silver. Both are described as 'woven' but appear to have been hand-knitted. Each row contains eight stitches and connects to the next row by a ninth. Figure 48 shows that the pattern is constructed using an equilateral triangle and a semicircle. The secrets in the mesh reveal that the soul and body are knitted together, as one, during a lifetime on Earth—by God (99999).

One of the stones in the lower foot-cone girdle is missing and another damaged.

The Secrets of the Foot-Cone

The foot-cone is described as subconical, meaning that it is cone-shaped to a certain degree but becomes more rounded as it progresses to the cone tip, terminating in the shape of a Gothic arch. It has a foot flange that is sandwiched between two similar rings (figure 47), the so-called upper foot girdle and the lower foot girdle.

The upper foot girdle (figure 47)—the one visible when viewed from above—originally carried eight miniature decorated panels that fit into dedicated slots in the ring. Four of the original eight are missing. The remaining four are made of gold-plated cast bronze, patterned with sharply angular [zigzag] interlaced knot-work. Originally eight almost-square blue glass studs were distributed around the ring in dedicated slots so as to form an octagonal shape. One of the studs is now missing and another damaged. The mass of each stud consists of blue glass. Two are patterned, in the centre, with a red cross surrounded by a yellow L-shape in each of the four corners [such that pairs of L-shapes form brackets around the central cross] and two have the colour scheme reversed.

The lower foot girdle can only be seen when the foot-cone is viewed from below. It is similar in style and construction to the one above; however, the decorative panels differ in decoration and material: four of the eight decorative panels carry the looping knot-work pattern, shown in figure 50b [also found in the bowl girdle] and are made from silver. Another two, made from copper, carry swastika patterns, representing the solar wind as seen from Earth (more on these later).

The Secrets of the Mesh-mat Panels

The remaining two panels are each made from a mesh-mat of very fine wire, one of bronze and the other one of silver. Both are described as 'woven' but appear to have been hand-knitted. Each row contains eight stitches and connects to the next row by a ninth. Figure 48 shows that the pattern is constructed using an equilateral triangle and a semicircle. The secrets in the mesh reveal that the soul and body are knitted together, as one, during a lifetime on Earth—by God (99999).

One of the stones in the lower foot-cone girdle is missing and another damaged.

Upper Foot Girdle: Stone and Panel Mounting

Figure 47. Foot-cone, inside the upper foot girdle, seen from above without the bowl (after re-assembly following restoration). Four decorative panels (here shown simplified in shades of grey) are missing (indicated by the empty circular rivet holes). One stone is missing and one damaged. The square bolt-hole was modified with a cut into the foot-cone, by the jeweller Johnson, in an attempt to tighten the complete assembly with a keyed-interface.

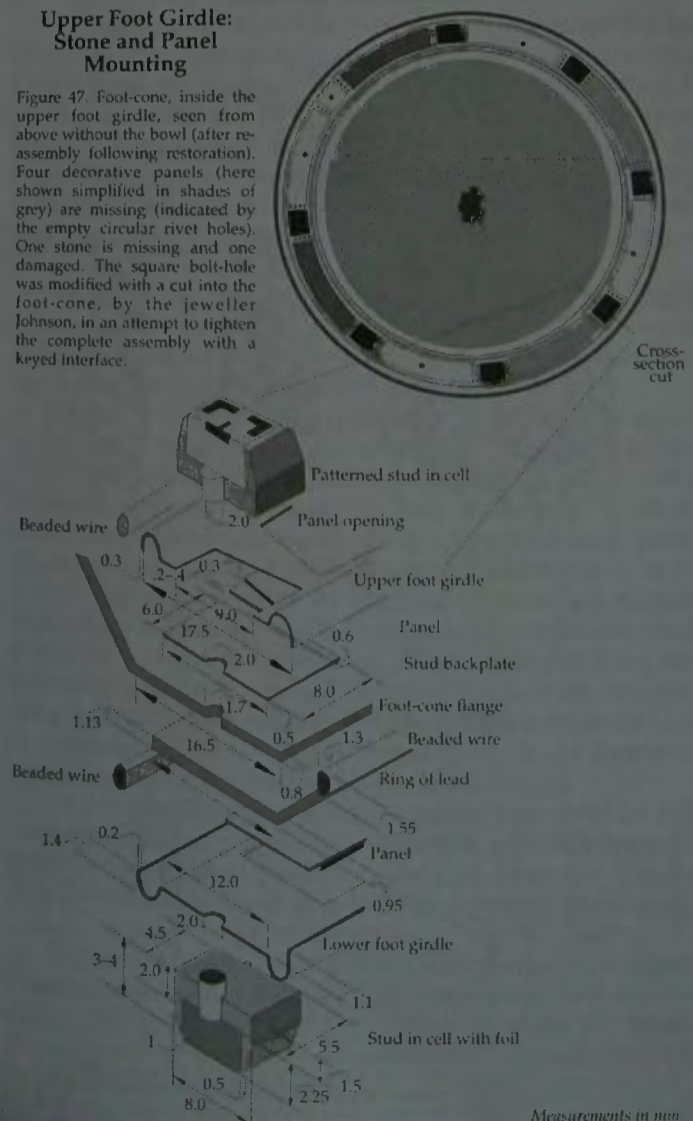

Measurements in mm

Upper Foot Girdle: Stone and Panel Mounting

Figure 47. Foot-cone, inside the upper foot girdle, seen from above without the bowl (after re-assembly following restoration). Four decorative panels (here shown simplified in shades of grey) are missing (indicated by the empty circular rivet holes). One stone is missing and one damaged. The square bolt-hole was modified with a cut into the foot-cone, by the jeweller Johnson, in an attempt to tighten the complete assembly with a keyed interface.

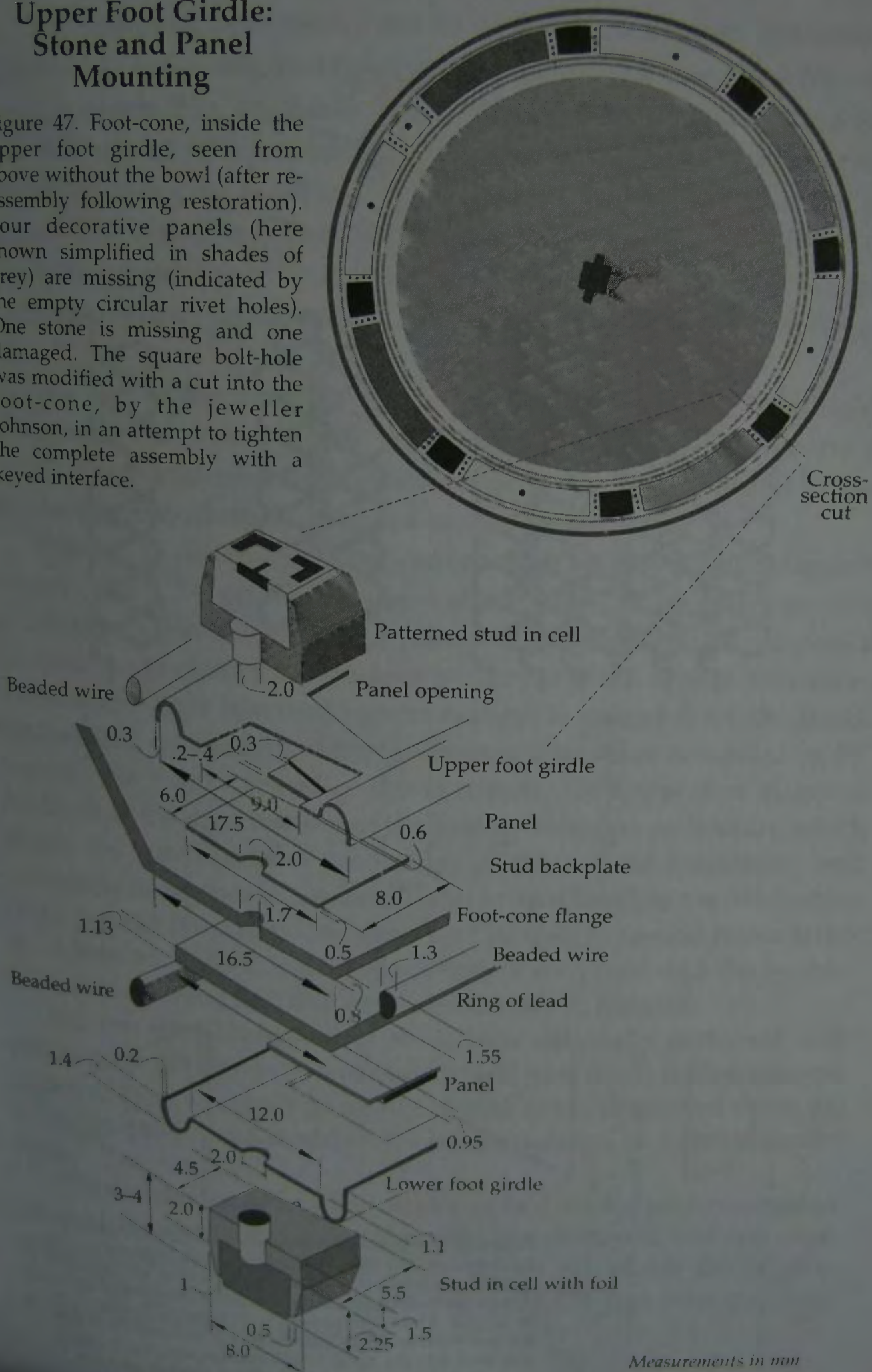

Upper foot-girdle; Stone and Panel Mounting

Figure 47. Foot-cone, inside the upper foot-girdle, seen from above without the bowl (after re-assembly following restoration). Four decorative panels (here shown simplified in shades of grey) are missing (indicated by the empty circular rivet-holes). One stone is missing and one damaged. The square bolt-hole was modified with a cut into the foot-cone, by the jeweller Johnson, in an attempt to tighten the complete assembly with a keyed-interface.

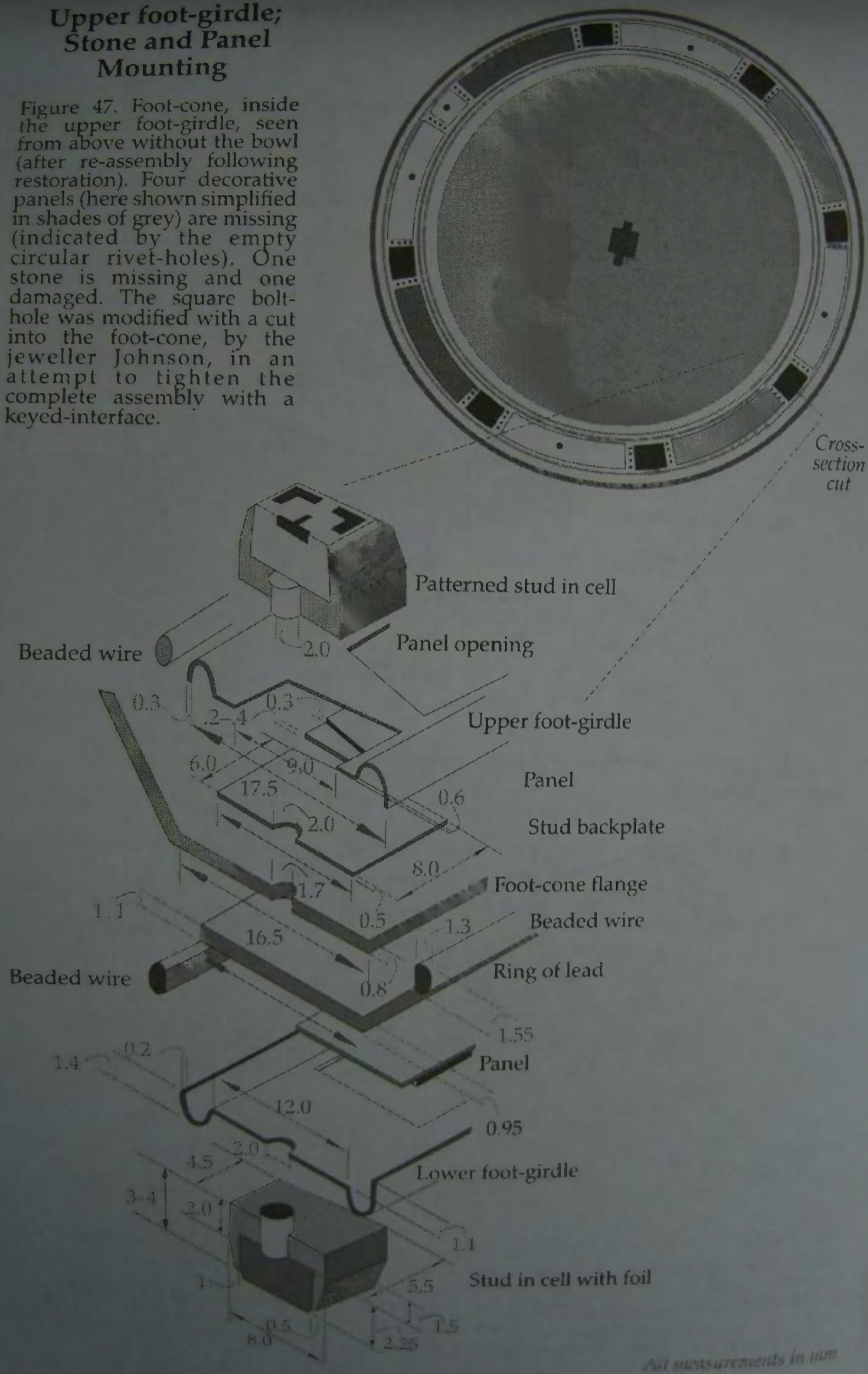

The Secrets in the Mesh

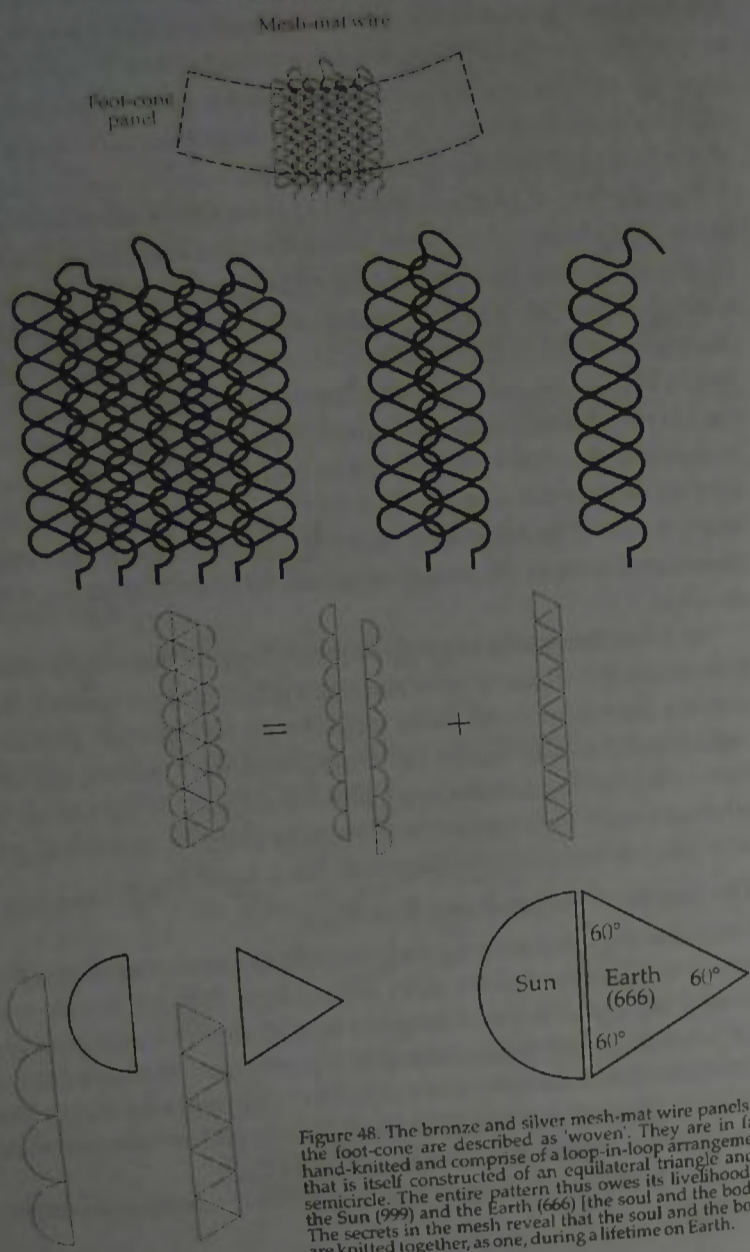

Figure 48. The bronze and silver mesh-mat wire panels in the foot-cone are described as 'woven'. They are in fact hand-knitted and comprise a loop-in-loop arrangement that is itself constructed of an equilateral triangle and a semicircle. The entire pattern thus owes its livelihood to the Sun (999) and the Earth (666) [the soul and the body]. The secrets in the mesh reveal that the soul and the body are knitted together, as one, during a lifetime on Earth.

The fastening bolt turned out to be made of copper, not iron [as claimed by Dunraven] and fixed to the inside of the bowl by a rounded head. It seems that, originally, the copper bolt terminated with a split pin, the legs of which were spread apart beneath the quartz crystal mount to fasten the bowl to the foot-cone. One of the legs of the pin (figure 46a) is now missing. In 1962 the British Museum modified the connecting mechanism by drilling and tapping the central bolt to take a screw to replace the damaged split-pin retention mechanism (figure 46).

The end of the assembled fixing is concealed by another highly decorated gold-plated bronze washer-type interface in the centre of which sits an enormous subconical quartz crystal surrounded by five tiny semispherical studs arranged as a pentagon.

Quartz is intimately associated with light (electromagnetic energy—God). When it is mechanically stressed it generates an electric voltage. Conversely, when a voltage is applied across the crystal it vibrates at a frequency determined by the cut of the crystal. Moreover, when visible light (electromagnetic energy) is passed through quartz the electrical component of the electromagnetic wave is twisted by 45° towards the magnetic end of the spectrum. We know that magnetic fields affect the manufacture of the timing hormone melatonin which affects the consequential production of the follicle-stimulating and luteinising hormones in females. These in turn regulate the production of the fertility hormones oestrogen and progesterone and hence fertility in females. Quartz is thus synonymous with light and the 28-day spinning Sun that regulates fertility in females.

All five tiny semispherical studs were originally patterned with beaded wire but now only two undamaged ones retain the microscopic patterns. They are made primarily of blue glass, enamelled using the *champlevé* technique found on the other studs but on a much smaller scale.

The five circular blue spherical stones, laid-out as a *pentagon* around the central quartz crystal, and the eight square stones, laid out as an *octagon* around the lower-foot girdle (figure 49) enable the calculation of the 11.49-year, the 187-year and the 18,139-year solar magnetic cycles (described in Appendix 4).

The Secrets of the Bowl and the Bowl Girdle

The bowl and foot-cone are made of beaten lathe-polished silver and the

The Secrets in the Mesh

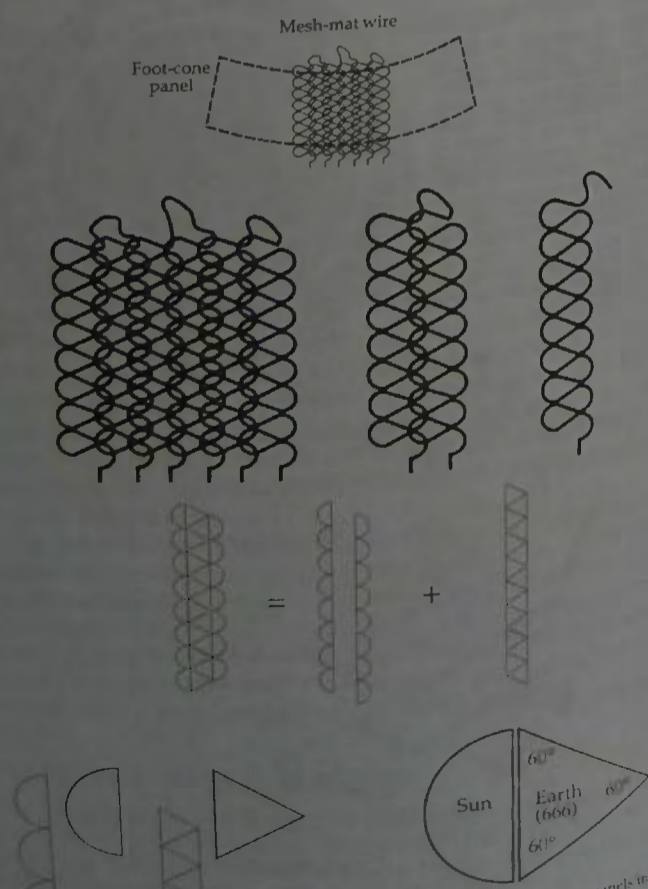

Figure 48. The bronze and silver mesh-mat wire panels in the foot-cone are described as 'woven'. They are in fact hand-knitted and comprise a loop-in-loop arrangement that is itself constructed of an equilateral triangle and a semicircle. The entire pattern thus owes its livelihood to the Sun (999) and the Earth (666) [the soul and the body]. The secrets in the mesh reveal that the soul and the body are knitted together, as one, during a lifetime on Earth.

The fastening bolt turned out to be made of copper, not iron [as claimed by Dunraven], and fixed to the inside of the bowl by a rounded head. It seems that, originally, the copper bolt terminated with a split pin, the legs of which were spread apart beneath the quartz crystal mount to fasten the bowl to the foot-cone. One of the legs of the pin (figure 46a) is now missing. In 1962 the British Museum modified the connecting mechanism by drilling and tapping the central bolt to take a screw to replace the damaged split-pin retention mechanism (figure 46).

The end of the assembled fixing is concealed by another highly decorated gold-plated bronze washer-type interface in the centre of which sits an enormous subconical quartz crystal surrounded by five tiny semispherical studs arranged as a pentagon.

Quartz is intimately associated with light (electromagnetic energy—God). When it is mechanically stressed it generates an electric voltage. Conversely, when a voltage is applied across the crystal it vibrates at a frequency determined by the cut of the crystal. Moreover, when visible light (electromagnetic energy) is passed through quartz, the electrical component of the electromagnetic wave is twisted by 45° towards the magnetic end of the spectrum. We know that magnetic fields affect the manufacture of the timing hormone melatonin, which affects the consequential production of the follicle-stimulating and luteinising hormones in females. These in turn regulate the production of the fertility hormones oestrogen and progesterone and hence fertility in females. Quartz is thus synonymous with light and the twenty-eight-day spinning Sun that regulates fertility in females.

All five tiny semispherical studs were originally patterned with beaded wire but now only two undamaged ones retain the microscopic patterns. They are made primarily of blue glass, enamelled using the *champlevé* technique found on the other studs but on a much smaller scale.

The five circular blue spherical stones, laid out as a *pentagon* around the central quartz crystal, and the eight square stones, laid out as an *octagon* around the lower foot girdle (figure 49), enable the calculation of the 11.49-year, the 187-year and the 18,139-year solar magnetic cycles (described in appendix 4).

The Secrets in the Mesh

Mesh-mat wire

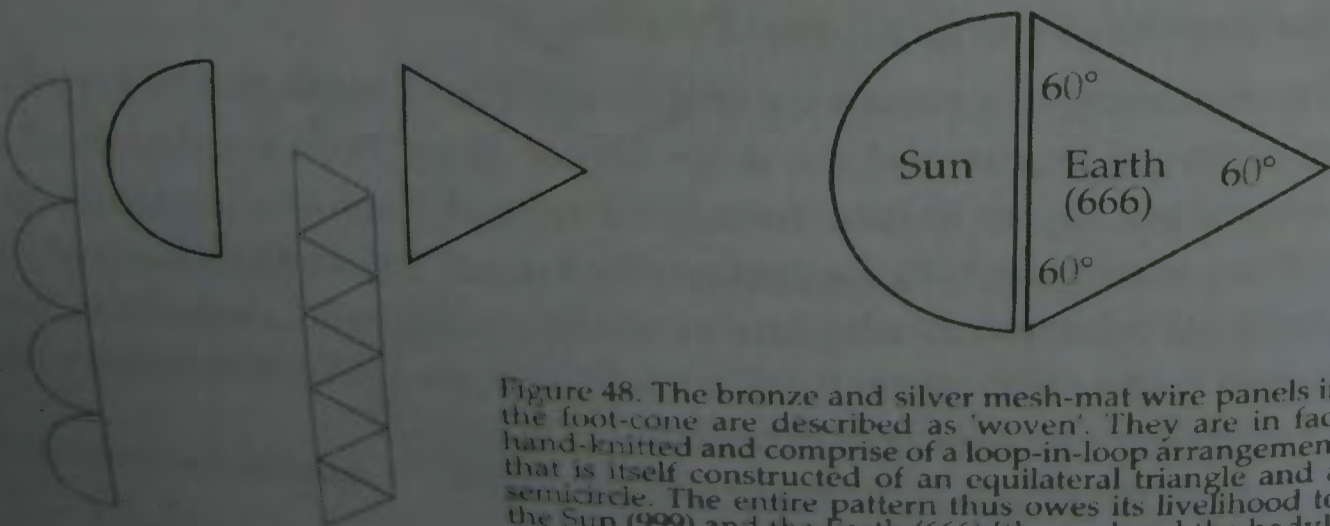
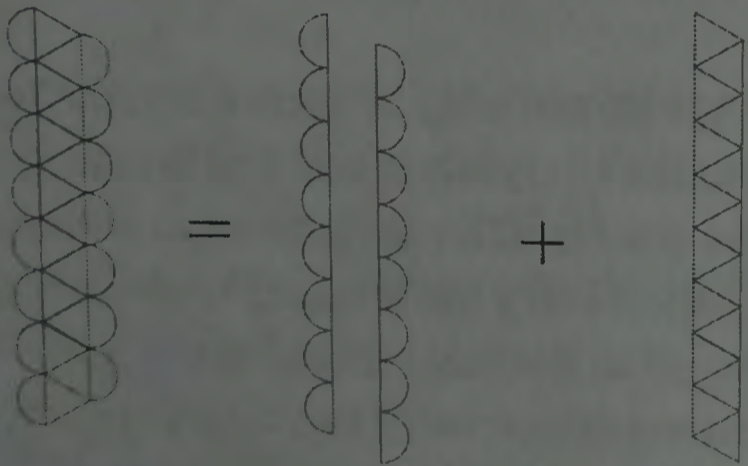
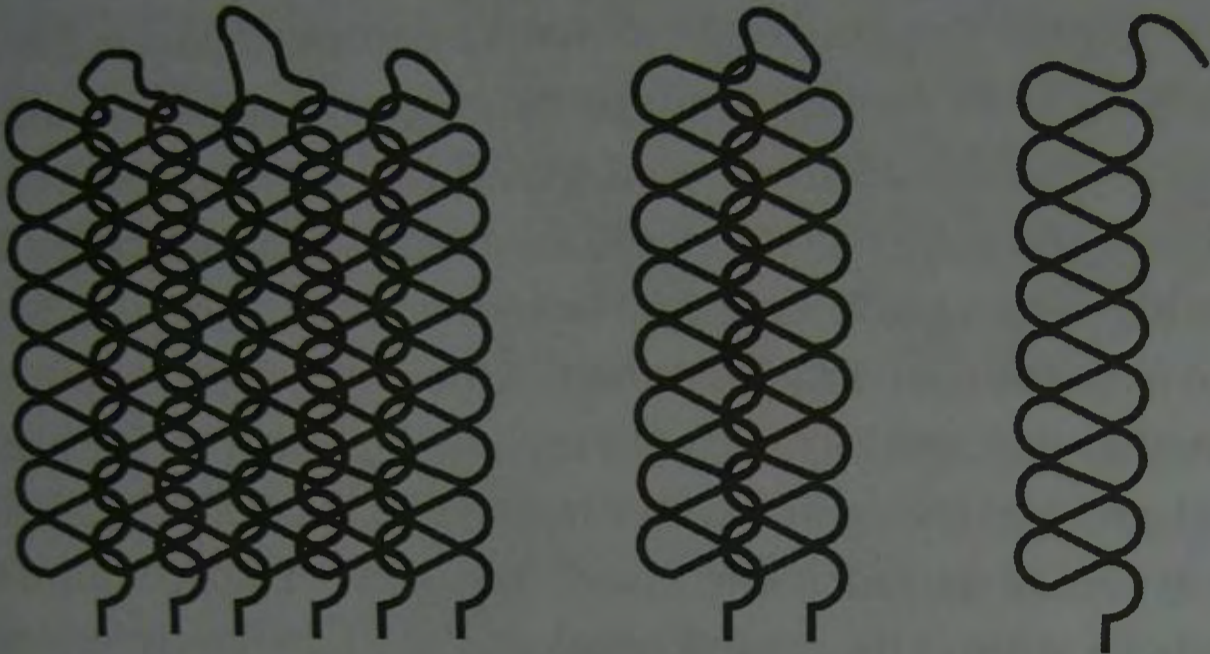
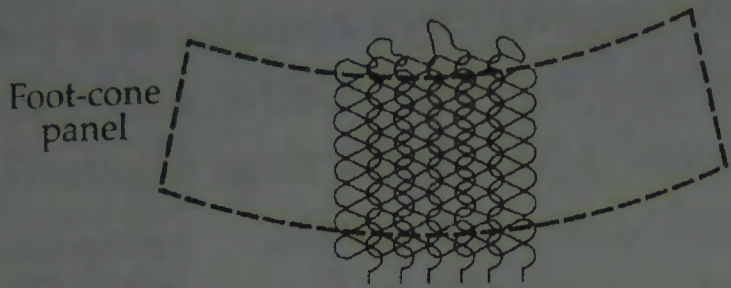

Figure 48. The bronze and silver mesh-mat wire panels in the foot-cone are described as 'woven'. They are in fact hand-knitted and comprise of a loop-in-loop arrangement that is itself constructed of an equilateral triangle and a semicircle. The entire pattern thus owes its livelihood to the Sun (999) and the Earth (666) [the soul and the body]. The secrets in the mesh reveal that the soul and the body are knitted together, as one, during a lifetime on Earth.

The Secrets in the Mesh

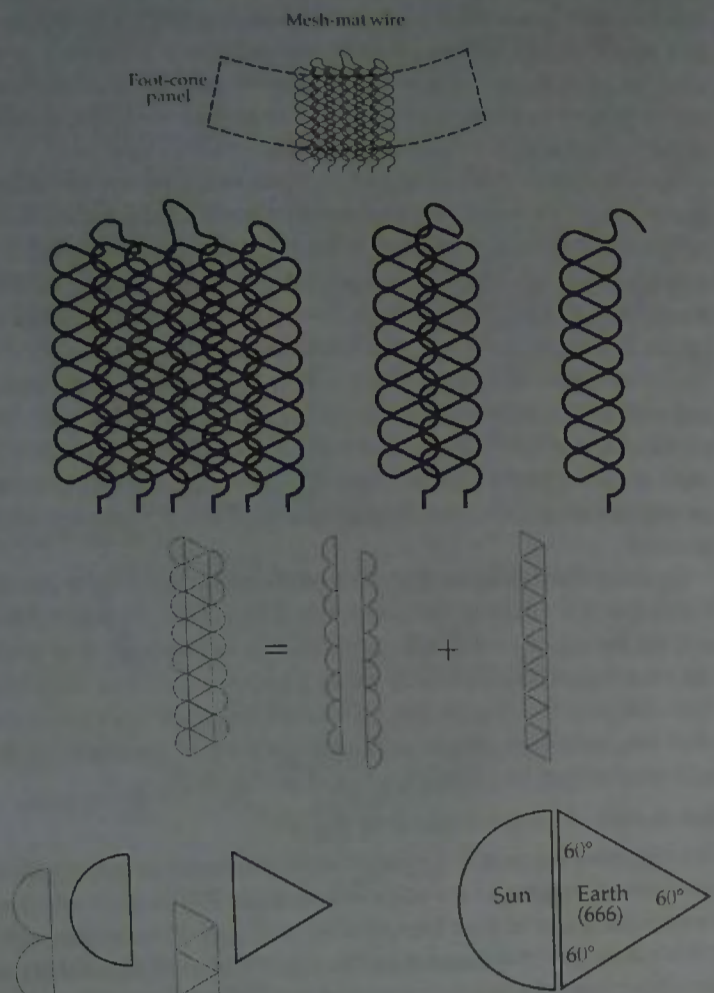

Figure 48. The bronze and silver mesh-mat wire panels in the foot-cone are described as 'woven'. They are in fact hand-knitted and comprise of a loop-in-loop arrangement that is itself constructed of an equilateral triangle and a semicircle. The entire pattern thus owes its livelihood to the Sun (999) and the Earth (666) [the soul and the body]. The secrets in the mesh reveal that the soul and the body are knitted together, as one, during a lifetime on Earth.

The fastening bolt turned out to be made of copper, not iron [as claimed by Dunraven] and fixed to the inside of the bowl by a rounded head. It seems that, originally, the copper bolt terminated with a split pin, the legs of which were spread apart beneath the quartz crystal mount to fasten the bowl to the foot-cone. One of the legs of the pin (figure 46a) is now missing. In 1962 the British Museum modified the connecting mechanism by drilling and tapping the central bolt to take a screw to replace the damaged split-pin retention mechanism (figure 46).

The end of the assembled fixing is concealed by another highly decorated gold-plated bronze washer-type interface in the centre of which sits an enormous subconical quartz crystal surrounded by five tiny semispherical studs arranged as a pentagon.

Quartz is intimately associated with light (electromagnetic energy—God). When it is mechanically stressed it generates an electric voltage. Conversely, when a voltage is applied across the crystal it vibrates at a frequency determined by the cut of the crystal. Moreover, when visible light (electromagnetic energy) is passed through quartz the electrical component of the electromagnetic wave is twisted by 45° towards the magnetic end of the spectrum. We know that magnetic fields affect the manufacture of the timing hormone melatonin which affects the consequential production of the follicle-stimulating and luteinising hormones in females. These in turn regulate the production of the fertility hormones oestrogen and progesterone and hence fertility in females. Quartz is thus synonymous with light and the 28-day spinning Sun that regulates fertility in females.

All five tiny semispherical studs were originally patterned with beaded wire but now only two undamaged ones retain the microscopic patterns. They are made primarily of blue glass, enamelled using the champlevé technique found on the other studs but on a much smaller scale.

The five circular blue spherical stones, laid-out as a pentagon around the central quartz crystal, and the eight square stones, laid out as an octagon around the lower-foot girdle (figure 49) enable the calculation of the 11.49-year, the 187-year and the 18,139-year solar magnetic cycles (described in Appendix 4).

The Secrets of the Bowl and the Bowl Girdle

The bowl and foot-cone are made of beaten lathe-polished silver and the

The Secrets in the Mesh

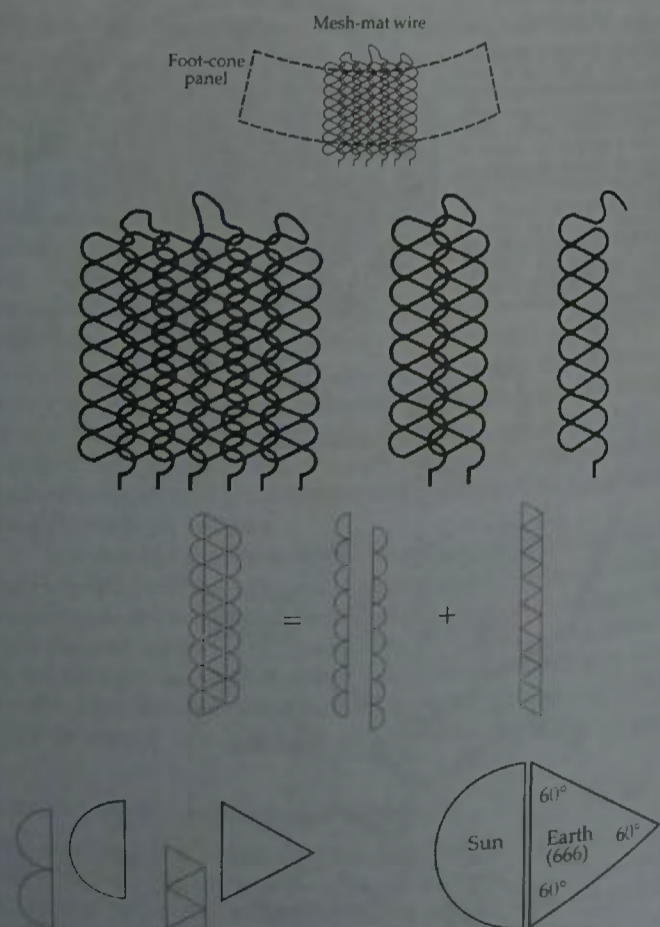

Figure 48. The bronze and silver mesh-mat wire panels in the foot-cone are described as 'woven'. They are in fact hand-knitted and comprise a loop-in-loop arrangement that is itself constructed of an equilateral triangle and a semicircle. The entire pattern thus owes its livelihood to the Sun (999) and the Earth (666) [the soul and the body]. The secrets in the mesh reveal that the soul and the body are knitted together, as one, during a lifetime on Earth.

The fastening bolt turned out to be made of copper, not iron [as claimed by Dunraven], and fixed to the inside of the bowl by a rounded head. It seems that, originally, the copper bolt terminated with a split pin, the legs of which were spread apart beneath the quartz crystal mount to fasten the bowl to the foot-cone. One of the legs of the pin (figure 46a) is now missing. In 1962 the British Museum modified the connecting mechanism by drilling and tapping the central bolt to take a screw to replace the damaged split-pin retention mechanism (figure 46).

The end of the assembled fixing is concealed by another highly decorated gold-plated bronze washer-type interface in the centre of which sits an enormous subconical quartz crystal surrounded by five tiny semispherical studs arranged as a pentagon.

Quartz is intimately associated with light (electromagnetic energy—God). When it is mechanically stressed it generates an electric voltage. Conversely, when a voltage is applied across the crystal it vibrates at a frequency determined by the cut of the crystal. Moreover, when visible light (electromagnetic energy) is passed through quartz, the electrical component of the electromagnetic wave is twisted by 45° towards the magnetic end of the spectrum. We know that magnetic fields affect the manufacture of the timing hormone melatonin, which affects the consequential production of the follicle-stimulating and luteinising hormones in females. These in turn regulate the production of the fertility hormones oestrogen and progesterone and hence fertility in females. Quartz is thus synonymous with light and the twenty-eight-day spinning Sun that regulates fertility in females.

All five tiny semispherical studs were originally patterned with beaded wire but now only two undamaged ones retain the microscopic patterns. They are made primarily of blue glass, enamelled using the champlevé technique found on the other studs but on a much smaller scale.

The five circular blue spherical stones, laid out as a pentagon around the central quartz crystal, and the eight square stones, laid out as an octagon around the lower foot girdle (figure 49), enable the calculation of the 11.49-year, the 187-year and the 18,139-year solar magnetic cycles (described in appendix 4).

Foot-cone Sacred Geometry



Figure 49. The eight almost-square blue glass studs, in the lower foot-girdle and the five circular blue studs surrounding the central mount make the geometric shapes of an octagon and a pentagon that together can be used to track the 11,49-year, the 187-year and the 18,139-year solar magnetic cycles (see Appendix 4).

two handles from cast silver. The handles are attached to the bowl just above what is described as, on each side, an escutcheon plate [because it resembles a shield with a coat of arms]. To soften the lip of the bowl a gold-plated brass moulded ring is attached to the rim of the bowl.

Two large solar-crosses, one either side of the bowl (plate 23), in-between the handles, dominate the main bowl decoration. The solar-cross describes the magnetic structure of the Sun and is found only in the halo of Christ (figure 2b), associating the cup with Christ. The outline of each cross and the compartments within each cross are made from square (viewed in cross-section) silver wire, representing the silver cord or cable-tow, which is associated with the soul, discussed earlier. Each aperture of the pattern is decorated with various scroll and double-scroll patterns from beaded wire and then the whole of each aperture has been gold-plated. Four tiny semispherical glass studs are set into silver-wire mounts spaced at 90° intervals—two blue glass studs and two red ones made of wax—that Dunraven originally described as being made of Amber. The four studs hide rivets that attach each Solar cross to the bowl.

The Secrets of the Bowl and the Bowl Girdle

The bowl and foot-cone are made of beaten lathe-polished silver and the two handles from cast silver are attached to the bowl just above what is described as, on each side, an escutcheon plate [because it resembles a shield with a coat of arms]. To soften the lip of the bowl a gold-plated brass moulded ring is attached to the rim of the bowl.

Two large solar crosses, one either side of the bowl (figure 49), in-between the handles, dominate the main bowl decoration. The solar cross describes the magnetic structure of the Sun and is found only in the halo of Christ (figures 2d and e), associating the cup with Christ. The outline of each cross and the compartments within each cross are made from square (viewed in cross-section) silver wire, representing the silver cord or cable tow, which is associated with the soul, discussed earlier. Each aperture of the pattern is decorated with various scroll and double-scroll patterns from beaded wire and then the whole of each aperture has been gold-plated. Four tiny semispherical glass

Foot-cone Sacred Geometry



Figure 49. The eight almost-square blue glass studs, in the lower foot-girdle, and the five circular blue studs surrounding the central mount make the geometric shapes of an octagon and a pentagon that together can be used to track the 11,49-year, the 187-year and the 18,139-year solar magnetic cycles (see appendix 4).

The bowl girdle, like the foot-cone girdles, is cut with apertures, this time to accommodate twelve enamel stud mounts (figure 50) and ten decorative panels fabricated in the same way; each is made from a thin plate of gold that has been embossed with a pattern. The background of the pattern has then been cut away to provide openwork. Next, a treble layer of beaded wire was soldered on to the pattern ridges and then a copper plate fixed behind each panel, effectively blocking-up the holes in the openwork panel. The patterns on the panels vary: two of the plate patterns are described as ornithomorphic, type-A (figure 50). Four carry variations of the knot-work pattern, type-B; and the remaining four panels, described as zoomorphic, type-C (plate 23b), are decorated with a highly complex pattern of interlaced animal, bird and serpent designs that proved, here—along with type-A—far too complex and difficult to sketch). There are no decorative girdle panels beneath the handles.

The ten badly fitting panels were mixed-up each time the chalice was restored such that the correct manner of assembly is not known. Archaeologists eventually settled on the arrangement in figure 50a. They also numbered the bowl girdle studs from 1 to 6, from the split in the ring under one of the handles to the front (on the left-hand side) and again from the split in the ring to the front (on the right-hand side). The anachronistic panel arrangement draws attention to the missing panels beneath the handles, the first panel and the last panel; Jesus was the first and the last, the Alpha and the Omega. Jesus thus appears either side of each solar-cross (the Sun) on the bowl, as Venus appears either side of the Sun, again specifically associating the design of the cup with Jesus.

The bowl-girdle studs (figure 51) are of the low-profile gently rounded segmented-arch shape, made of bronze wire in-filled with glass enamel, champlévé style, like the Basse Yutz stud (c. 400 BC), patterned variously with different coloured glass. From visual and photographic inspection one of the studs is clearly missing from a mount adjacent to one of the handles, although this is not mentioned in the 1970 report. The stud is also seen to have been missing from the earliest known photograph of the chalice taken by Margaret Stokes who drew the illustrations for the Dunraven report in 1874. There is no evidence to suggest that this missing stud was ever fitted.

studs are set into silver-wire mounts spaced at 90° intervals—two blue glass studs and two red ones made of wax—that Dunraven originally described as being made of amber. The four studs hide rivets that attach each solar cross to the bowl.

The bowl girdle, like the foot-cone girdles, is cut with apertures, this time to accommodate twelve enamel stud mounts (figure 50) and ten decorative panels fabricated in the same way: each is made from a thin plate of gold that has been embossed with a pattern. The background of the pattern has then been cut away to provide openwork. Next, a treble layer of beaded wire was soldered on to the pattern ridges and then a copper plate fixed behind each panel, effectively blocking up the holes in the openwork panel. The patterns on the panels vary. Two of the plate patterns are described as ornithomorphic, type-A (figure 50); four carry variations of the knot-work pattern, type-B; and the remaining four panels, described as zoomorphic, type-C (plate 23b), are decorated with a highly complex pattern of interlaced animal, bird and serpent designs that proved, here—along with type-A—far too complex and difficult to sketch. There are no decorative girdle panels beneath the handles.

The ten badly fitting panels were mixed up each time the chalice was restored such that the correct manner of assembly is not known. Archaeologists eventually settled on the arrangement in figure 50a. They also numbered the bowl girdle studs from 1 to 6, from the split in the ring under one of the handles to the front (on the left-hand side) and again from the split in the ring to the front (on the right-hand side). The anachronistic panel arrangement draws attention to the missing panels beneath the handles, the first panel and the last panel; Jesus was the first and the last, the Alpha and the Omega. Jesus thus appears either side of each solar cross (the Sun) on the bowl, as Venus appears either side of the Sun, again specifically associating the design of the cup with Jesus.

The bowl girdle studs (figure 51) are of the low-profile, gently rounded, segmented-arch shape, made of bronze wire in-filled with glass enamel, champlévé style, like the Basse Yutz stud (c. 400 BC), patterned variously with different coloured glass. From visual and photographic inspection one of the studs is clearly missing from a mount adjacent to one of the handles, although this is not mentioned in the

Foot-cone Sacred Geometry

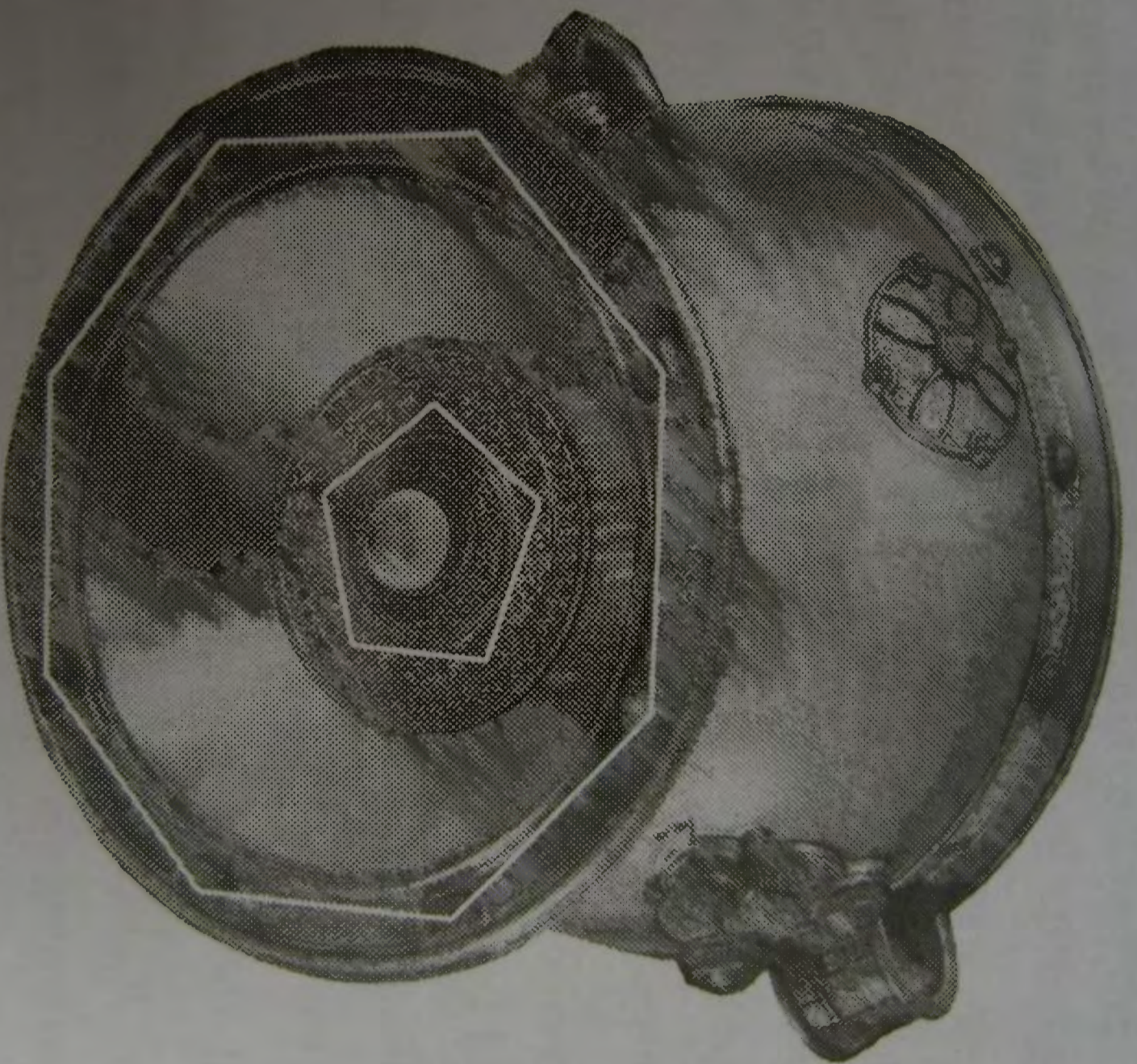

Figure 49. The eight almost-square blue glass studs, in the lower foot-girdle and the five circular blue studs surrounding the central mount make the geometric shapes of an octagon and a pentagon that together can be used to track the 11.49-year, the 187-year and the 18,139-year solar magnetic cycles (see Appendix 4).

... are attached to the bowl just

The Mystery of the Mixed-up Bowl Girdle Panels

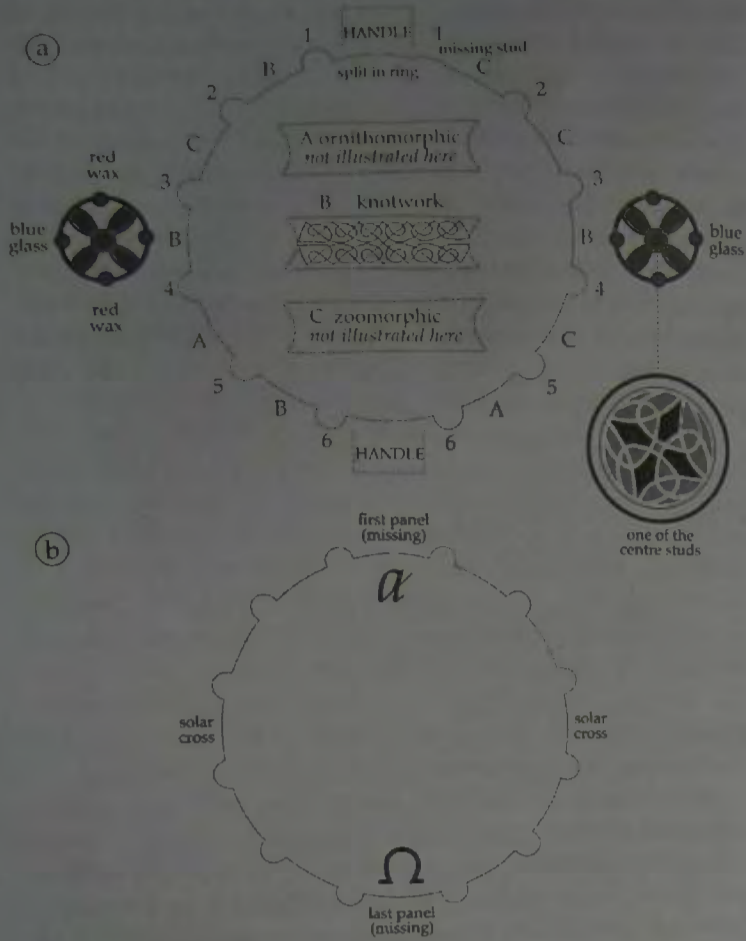

Figure 50. There are 10 panels in the bowl girdle; 2 of the ornithomorphic (A), 4 of the knotwork (B) and 4 of the zoomorphic (C) [there are no panels beneath the handles]. The 10 badly-fitting panels were mixed-up each time the chalice was restored such that the correct manner of assembly is not known. Archaeologists settled upon the arrangement in (a) above. They also numbered the studs as shown, from the split in the ring to the front. (b) The anachronistic panel arrangement draws attention to the missing panels, the first and the last. Jesus was the first and the last, the Alpha and the Omega; 'I am the Alpha and the Omega, the beginning and the end, the first and the last', Revelation, XXII, 13. Jesus thus appears either side of each solar-cross on the bowl; as Venus; 'I Jesus have sent my angel to testify unto you these things in the churches. I am the root and the offspring of David and the bright and morning star', Revelation XXII, 16.

The Meaning of the Missing Stud

The missing stud raises a question; were there meant to be 11 studs in the bowl-girdle or 12? The total number of pieces had already been established as 354 (representing the 354-day Druidic calendar). These two new numbers of 11 and 12 become significant when considering the length of the solar year; $354 + 11 = 365$ and $354 + 12 = 366$. There are either 365 days in a solar year or 366, in a solar leap year, confirming that the 354 pieces must refer to the number of days in a year—and that the cup must have been made by Celts around the time of Christ. It also confirms that one of the 12 rim-studs was deliberately left out, in common with the practice used by ancient civilizations, to draw attention to encoded information and also to prophecy the future betrayal of Jesus by Judas Iscariot.

The Mystery of the Script

Below each of the studs is carved the name of one of the 12 Apostles. As noted earlier, the names are written in insular majuscule script, persuading experts that the cup was engraved by monks at Lindisfarne. But the names of the Apostles in the Lindisfarne Gospels are written in Latinised-Greek whereas on the chalice they appear in Latin. Lindisfarne was established by the Irish monk St Aiden, who, like St Patrick, preferred not to speak Latin [Patrick preferred his Celtic Mayo-Irish]. If the Chalice was engraved by the monks of Lindisfarne why did they not use the same language and convention on the chalice as they used in the Lindisfarne Gospels? Why use Latin on the cup and Latinised-Greek in the Lindisfarne Gospels?

The Mystery of the Names

The 12 names as they appear on the bowl also raise questions; the name of Judas Iscariot, the so-called Disciple, who betrayed Jesus, is missing, which is understandable. But the name of the Apostle who replaced him, Mathius, is not included. If the monks of Lindisfarne had engraved the cup they would have known that Mathius had replaced Jesus—given that the Lindisfarne Gospels are based on the Latin Vulgate version of the Bible which contains the *Acts of the Apostles* naming Mathius as the replacement. Instead, the twelfth name on the chalice is that of St Paul, the one-time Roman Saul, who preached around the Mediterranean

The Mystery of the Mixed-up Bowl Girdle Panels

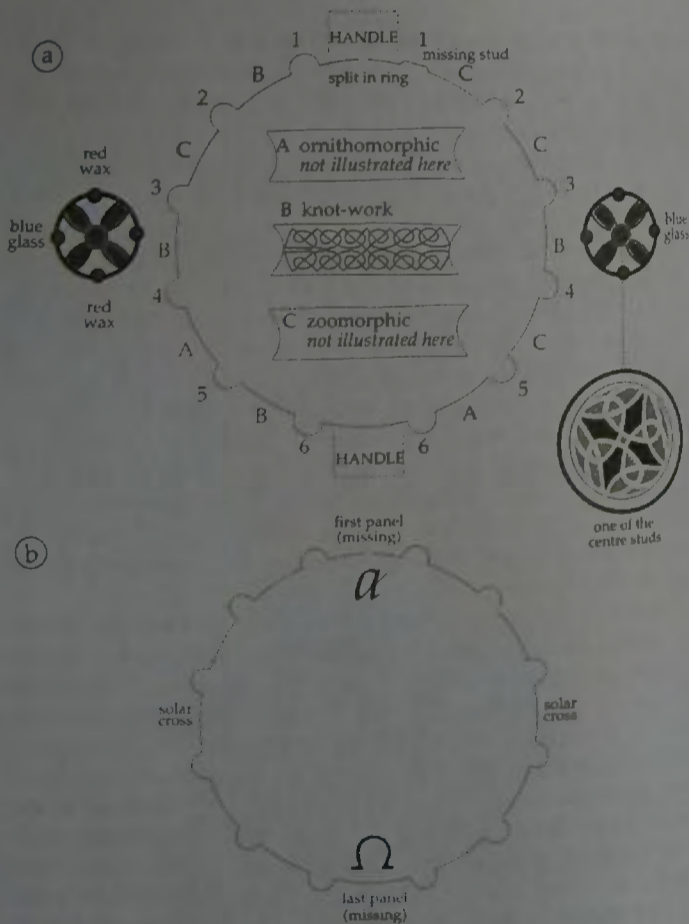

Figure 50. There are ten panels in the bowl girdle: two of the ornithomorphic (A), four of the knotwork (B) and four of the zoomorphic (C) [there are no panels beneath the handles]. The ten badly fitting panels were mixed up each time the chalice was restored such that the correct manner of assembly is not known. Archaeologists settled upon the arrangement in (a) above. They also numbered the studs as shown, from the split in the ring to the front. (b) The anachronistic panel arrangement draws attention to the missing panels, the first and the last. Jesus was the first and the last, the Alpha and the Omega; 'I am the Alpha and the Omega, the beginning and the end, the first and the last', Revelation, XXII, 13. Jesus thus appears either side of each solar cross on the bowl, as Venus; 'I Jesus have sent my angel to testify unto you these things in the churches. I am the root and the offspring of David and the bright and morning star' Revelation XXII, 16

Bowl Girdle Stud Mounting

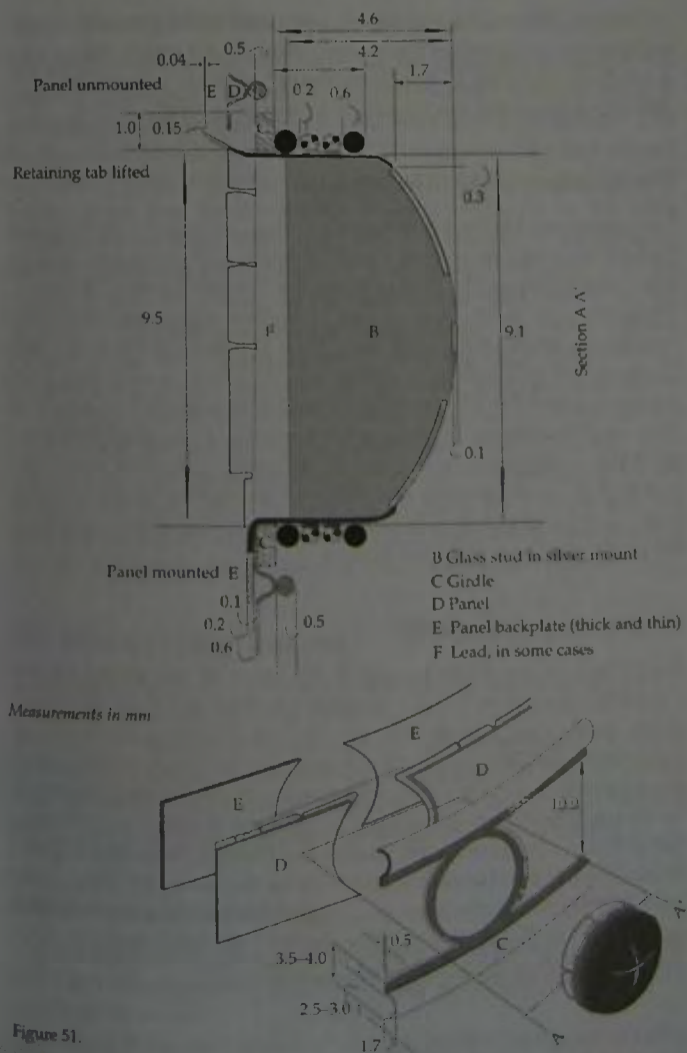

Figure 51.

The Mystery of the Mixed-up Bowl Girdle Panels

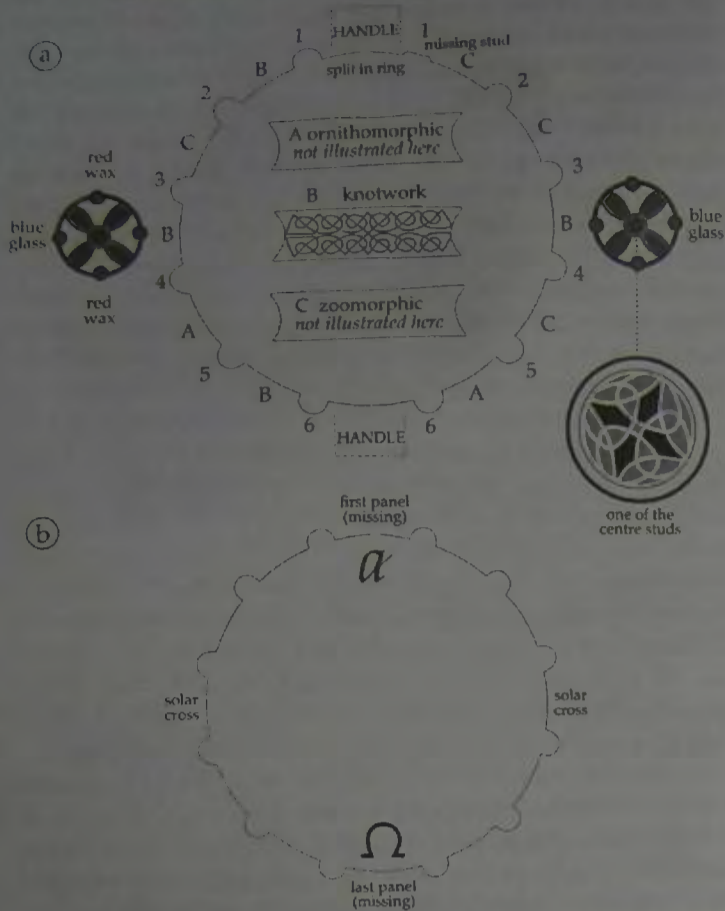

Figure 50. There are 10 panels in the bowl girdle; 2 of the ornithomorphic (A), 4 of the knotwork (B) and 4 of the zoomorphic (C) [there are no panels beneath the handles]. The 10 badly-fitting panels were mixed-up each time the chalice was restored such that the correct manner of assembly is not known. Archaeologists settled upon the arrangement in (a) above. They also numbered the studs as shown, from the split in the ring to the front. (b) The anachronistic panel arrangement draws attention to the missing panels, the first and the last. Jesus was the first and the last, the Alpha and the Omega, 'I am the Alpha and the Omega, the beginning and the end, the first and the last', Revelation, XXII, 13. Jesus thus appears either side of each solar-cross on the bowl; as Venus, 'I Jesus have sent my angel to testify unto you these things in the churches. I am the root and the offspring of David and the bright and morning star', Revelation XXII, 16.

The Meaning of the Missing Stud

The missing stud raises a question; were there meant to be 11 studs in the bowl-girdle or 12? The total number of pieces had already been established as 354 (representing the 354-day Druidic calendar). These two new numbers of 11 and 12 become significant when considering the length of the solar year; $354 + 11 = 365$ and $354 + 12 = 366$. There are either 365 days in a solar year or 366, in a solar leap year, confirming that the 354 pieces must refer to the number of days in a year—and that the cup must have been made by Celts around the time of Christ. It also confirms that one of the 12 rim-studs was deliberately left out, in common with the practice used by ancient civilizations, to draw attention to encoded information and also to prophecy the future betrayal of Jesus by Judas Iscariot.

The Mystery of the Script

Below each of the studs is carved the name of one of the 12 Apostles. As noted earlier, the names are written in insular majuscule script, persuading experts that the cup was engraved by monks at Lindisfarne. But the names of the Apostles in the Lindisfarne Gospels are written in Latinised-Greek whereas on the chalice they appear in Latin. Lindisfarne was established by the Irish monk St Aiden, who, like St Patrick, preferred not to speak Latin [Patrick preferred his Celtic Mayo-Irish]. If the Chalice was engraved by the monks of Lindisfarne why did they not use the same language and convention on the chalice as they used in the Lindisfarne Gospels? Why use Latin on the cup and Latinised-Greek in the Lindisfarne Gospels?

The Mystery of the Names

The 12 names as they appear on the bowl also raise questions; the name of Judas Iscariot, the so-called Disciple, who betrayed Jesus, is missing, which is understandable. But the name of the Apostle who replaced him, Mathius, is not included. If the monks of Lindisfarne had engraved the cup they would have known that Mathius had replaced Jesus—given that the Lindisfarne Gospels are based on the Latin Vulgate version of the Bible which contains the *Acts of the Apostles* naming Mathius as the replacement. Instead, the twelfth name on the chalice is that of St Paul, the one-time Roman Saul, who preached around the Mediterranean

The Mystery of the Mixed-up Bowl Girdle Panels

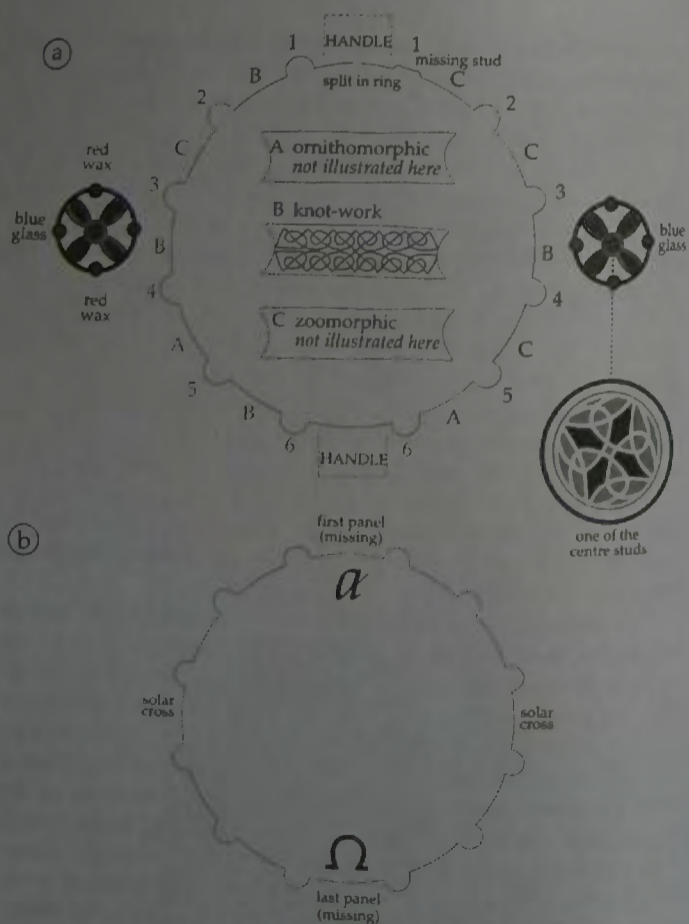

Figure 50. There are ten panels in the bowl girdle: two of the ornithomorphic (A), four of the knotwork (B) and four of the zoomorphic (C) [there are no panels beneath the handles]. The ten badly fitting panels were mixed up each time the chalice was restored such that the correct manner of assembly is not known. Archaeologists settled upon the arrangement in (a) above. They also numbered the studs as shown, from the split in the ring to the front. (b) The anachronistic panel arrangement draws attention to the missing panels, the first and the last. Jesus was the first and the last, the Alpha and the Omega, 'I am the Alpha and the Omega, the beginning and the end, the first and the last', Revelation, XXII, 13. Jesus thus appears either side of each solar cross on the bowl, as Venus, 'I Jesus have sent my angel to testify unto you these things in the churches. I am the root and the offspring of David and the bright and morning star', Revelation XXII, 16.

Bowl Girdle Stud Mounting

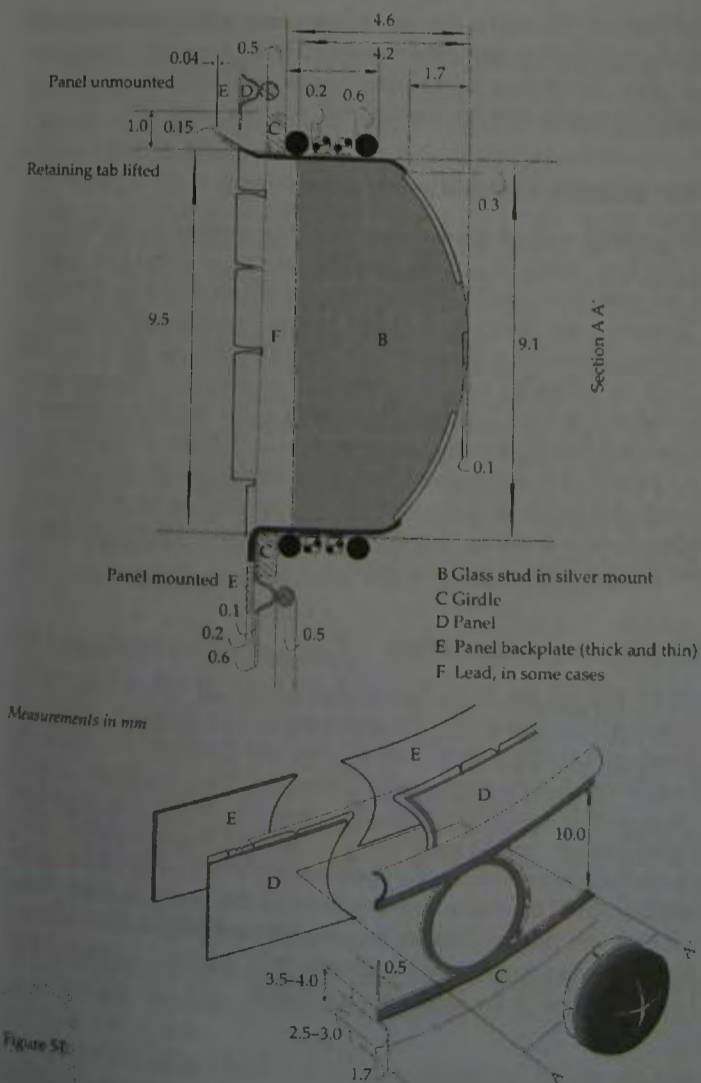
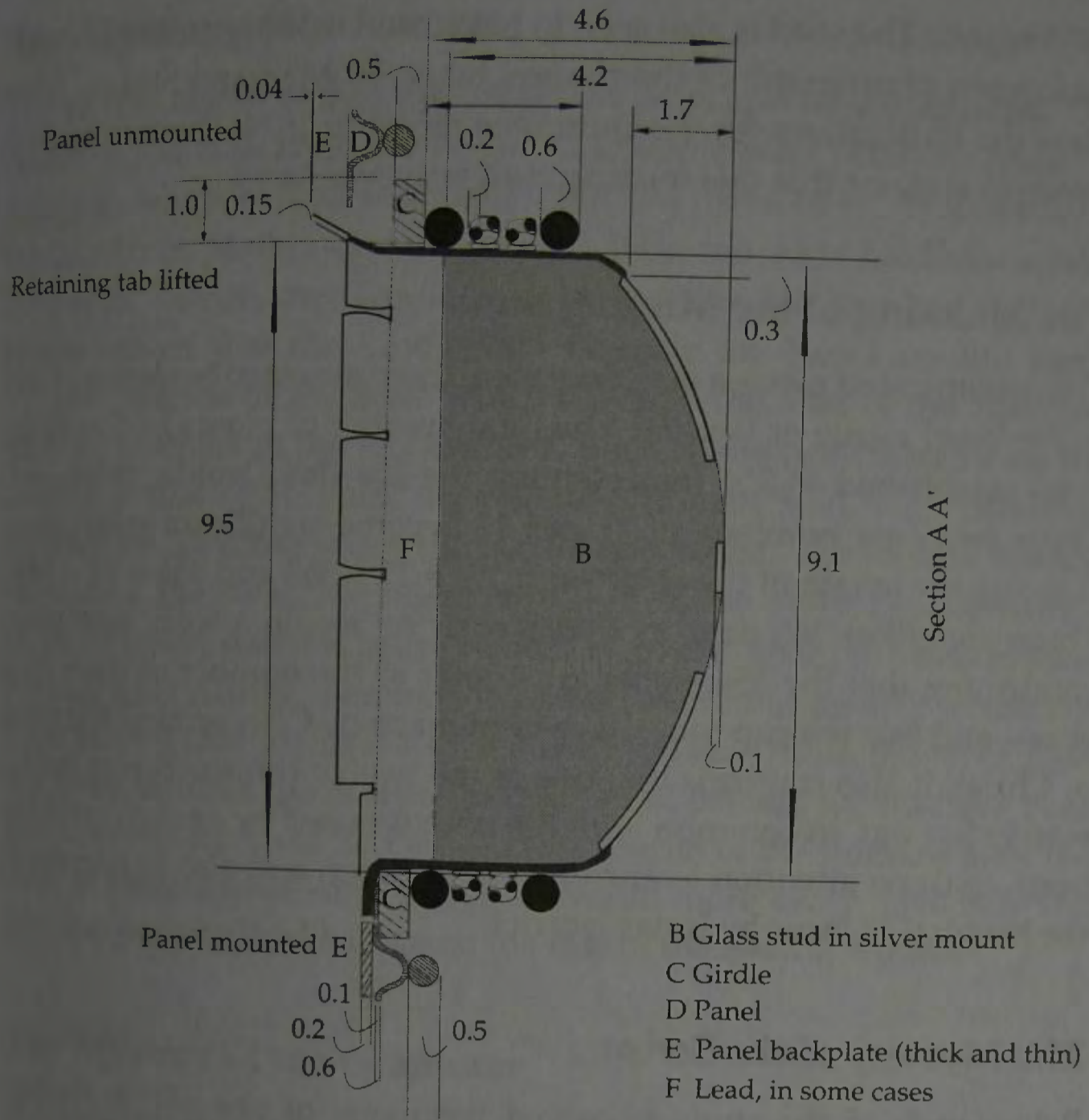

Figure 51

Bowl Girdle Stud Mounting



Measurements in mm

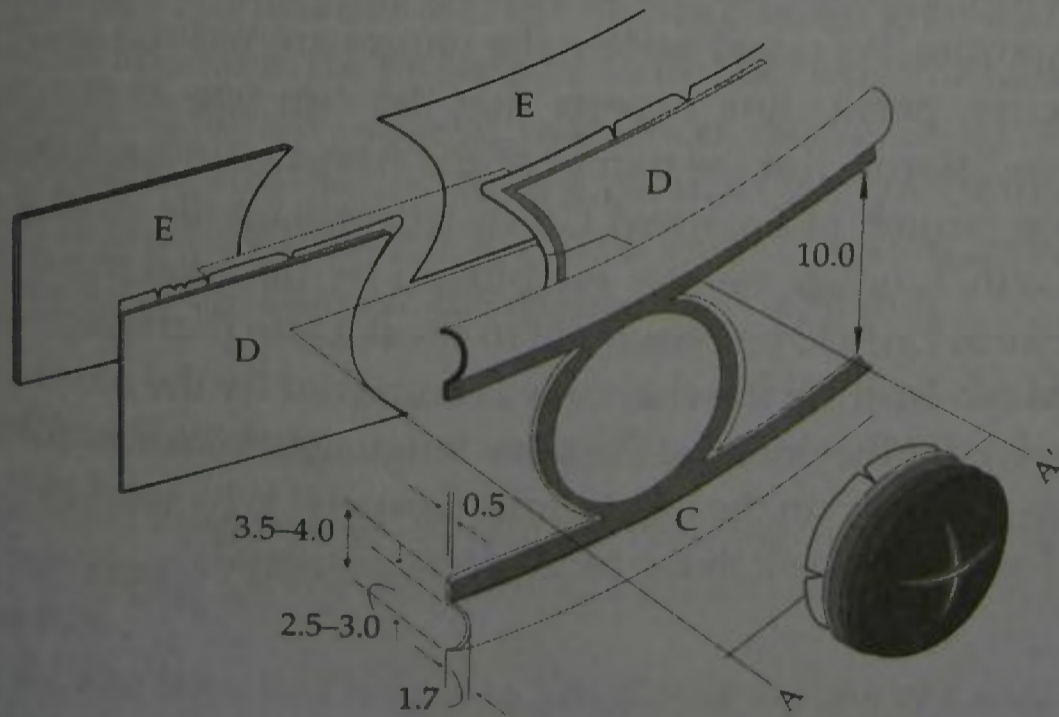
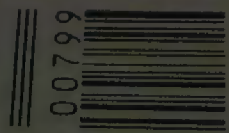

Figure 51.

our of the
 dles]. The
 he correct
 (a) above.
 t. (b) The
 nd the last.
 ne Omega,
 ears either
 y unto you
 bright and

asures of
 ame story
 concealed
 he higher
 Maurice
 s which
 my lie'



The Mystery of the Mixed-up Bowl Girdle Panels

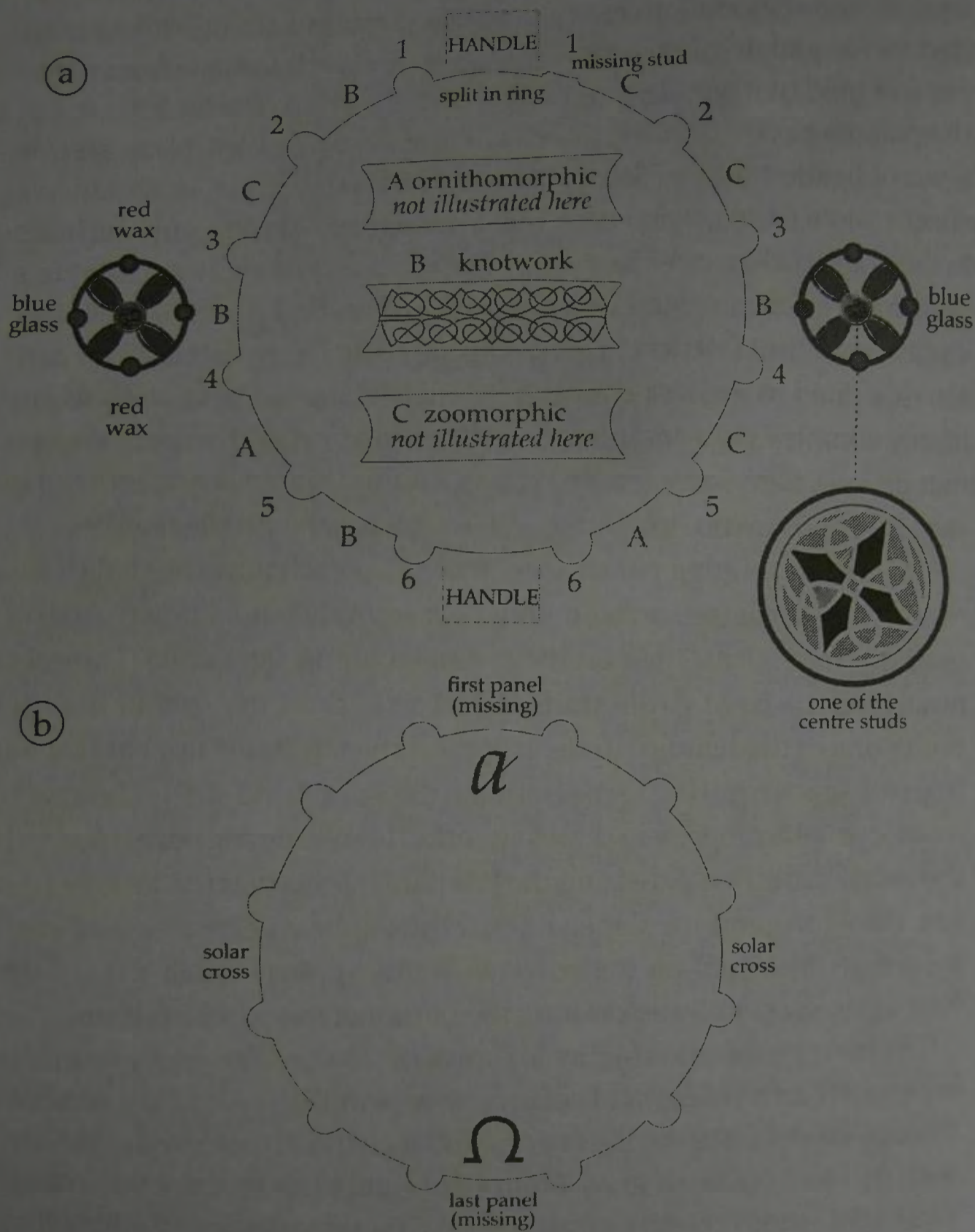

Figure 50. There are 10 panels in the bowl girdle; 2 of the ornithomorphic (A), 4 of the knotwork (B) and 4 of the zoomorphic (C) [there are no panels beneath the handles]. The 10 badly-fitting panels were mixed-up each time the chalice was restored such that the correct manner of assembly is not known. Archaeologists settled upon the arrangement in (a) above. They also numbered the studs as shown, from the split in the ring to the front. (b) The anachronistic panel arrangement draws attention to the missing panels, the first and the last. Jesus was the first and the last, the Alpha and the Omega, 'I am the Alpha and the Omega, the beginning and the end, the first and the last', Revelation, XXII, 13. Jesus thus appears either side of each solar-cross on the bowl; as Venus; 'I Jesus have sent my angel to testify unto you these things in the churches. I am the root and the offspring of David and the bright and morning star', Revelation XXII, 16.

Bowl Girdle Stud Mounting

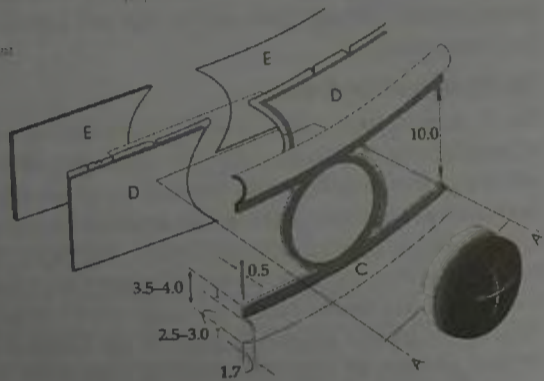
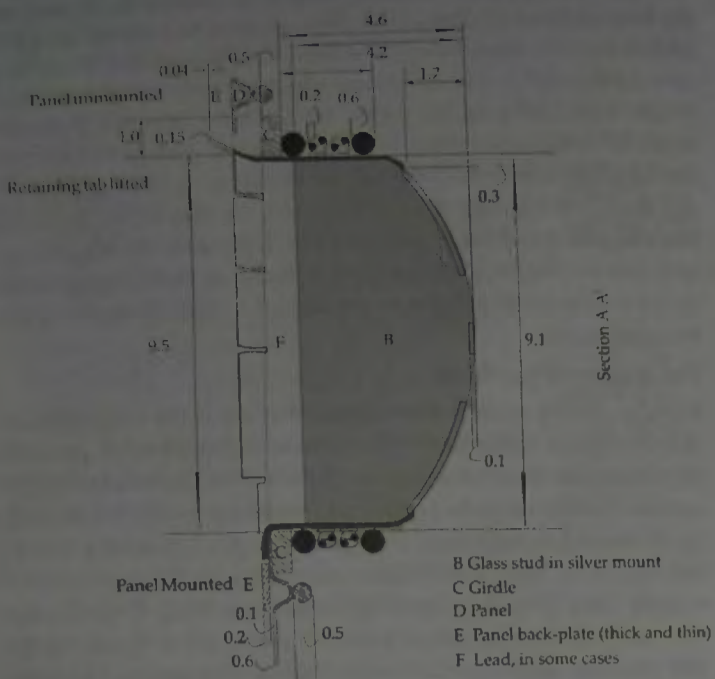

Figure 51.

during Roman times. The earliest known version of the New Testament comes from the early *Peshitto* manuscript precisely dated as being written in AD 464, after the death of King Arthur. King Arthur therefore, who died in around AD 450, would not have known that Mathius had replaced Judas. Arthur, however, having lived through the Roman occupation of Britain, would have been aware of the works of St Paul—the favourite of the Romans after the time of Constantine—and therefore would more likely have believed that the popular Paul had taken the role of the twelfth Apostle.

The Mystery of the Grammar

A linguistic scholar has pointed out that the names contain grammatical errors; ten names appear in the possessive sense but two—the Latin versions of Tatheus and Simon—appear in the nominative. St Aiden may not have favoured Latin but he was a scholar, as the Lindisfarne Gospels testify. It is unlikely therefore that educated clerics engraved the chalice. If clerics did not engrave the chalice then who did?

The Secrets of the Carving

The incorrect names of the Apostles supports the view that it was Arthur in AD 453 who incorrectly carved the name of Paul on the Chalice and not clerics in AD 698.

Arthur would also have had no axe to grind over the use of Latin, unlike the monks who were at loggerheads with Rome over the dating of Easter and the structure of the Church. He was no educated scholar and therefore more likely to make grammatical errors.

And the carving of the names on the cup is rough and crude (plate 23b) as though it has been done with the end of nail—an instrument intimately associated with the Crucifixion of Christ. It is patently clear that whoever carved the cup wished to convey the fact that they did not possess the skill of whoever manufactured it. But whoever it was, they knew it was the Holy Grail and engraved it to let others know.

The Secrets of the Dragons

The engraving has more to say; it continues in loops around the solar-crosses and beneath the handle escutcheons taking the shape of two conjoined dragonheads (figure 52). This 'mark of the Grail'—two anthropo-

The Mystery of the Mixed-up Bowl Girdle Panels

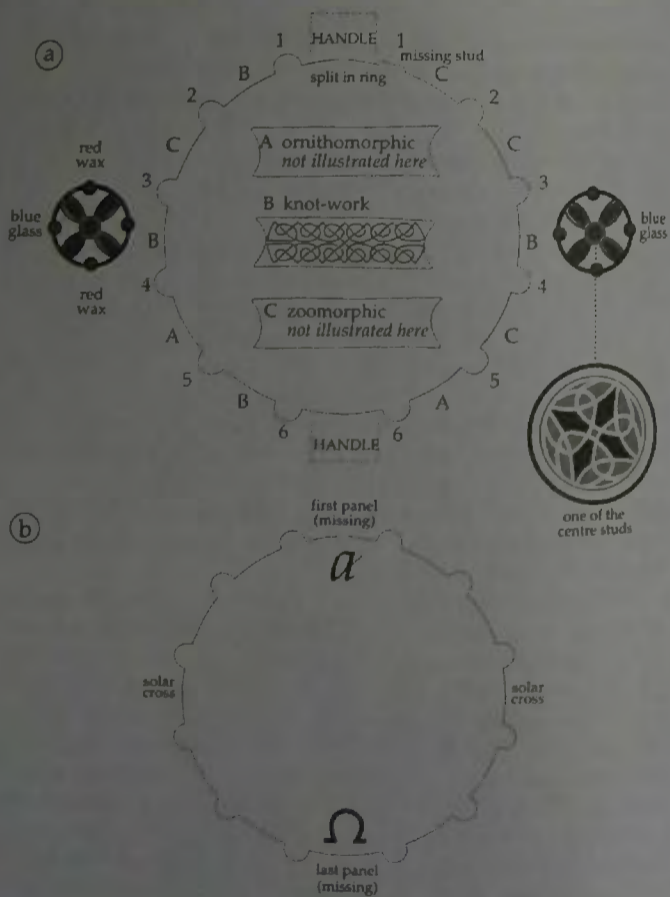
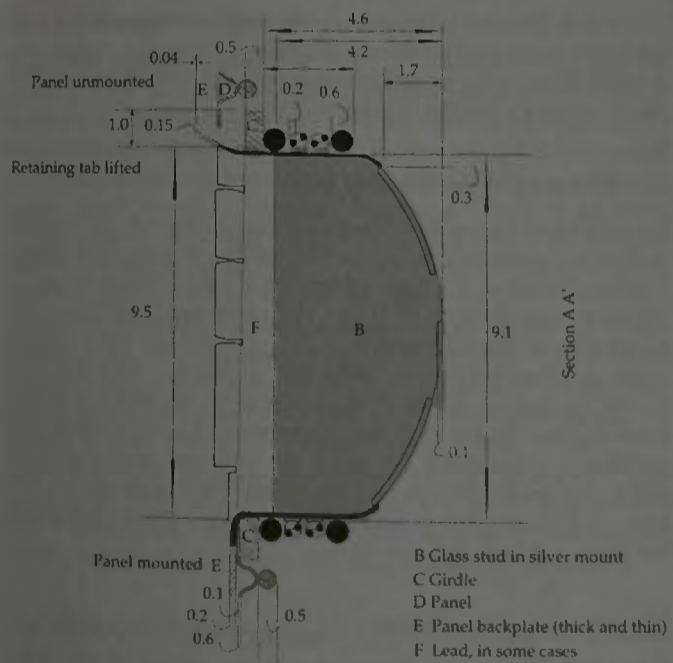

Figure 50. There are ten panels in the bowl girdle: two of the ornithomorphic (A), four of the knotwork (B) and four of the zoomorphic (C) [there are no panels beneath the handles]. The ten badly fitting panels were mixed up each time the chalice was restored such that the correct manner of assembly is not known. Archaeologists settled upon the arrangement in (a) above. They also numbered the studs as shown, from the split in the ring to the front. (b) The anachronistic panel arrangement draws attention to the missing panels, the first and the last. Jesus was the first and the last, the Alpha and the Omega: 'I am the Alpha and the Omega, the beginning and the end, the first and the last', Revelation, XXII, 13. Jesus thus appears either side of each solar cross on the bowl, as Venus: 'I Jesus have sent my angel to testify unto you these things in the churches. I am the root and the offspring of David and the bright and morning star' Revelation XXII, 16

Bowl Girdle Stud Mounting



Measurements in mm

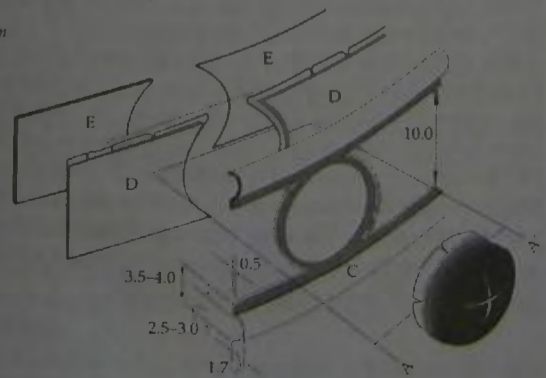
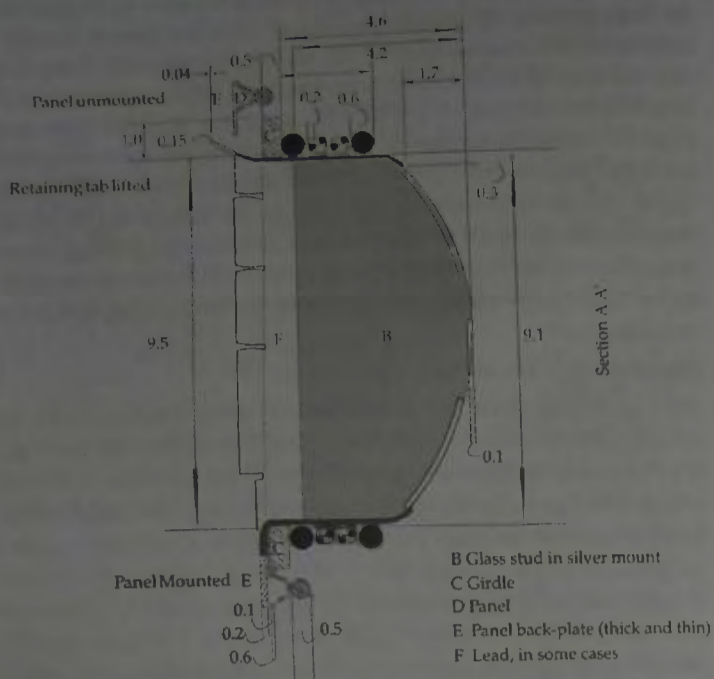

Figure 51.

Bowl Girdle Stud Mounting



All measurements in mm

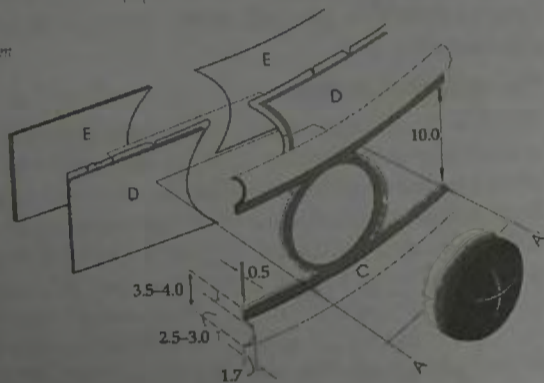

Figure 51.

during Roman times. The earliest known version of the New Testament comes from the early *Peshitto* manuscript precisely dated as being written in AD 464, after the death of King Arthur. King Arthur therefore, who died in around AD 450, would not have known that Mathius had replaced Judas. Arthur, however, having lived through the Roman occupation of Britain, would have been aware of the works of St Paul—the favourite of the Romans after the time of Constantine—and therefore would more likely have believed that the popular Paul had taken the role of the twelfth Apostle.

The Mystery of the Grammar

A linguistic scholar has pointed out that the names contain grammatical errors: ten names appear in the possessive sense but two—the Latin versions of Tatheus and Simon—appear in the nominative. St Aidan may not have favoured Latin but he was a scholar, as the Lindisfarne Gospels testify. It is unlikely therefore that educated clerics engraved the chalice. If clerics did not engrave the chalice then who did?

The Secrets of the Carving

The incorrect names of the Apostles supports the view that it was Arthur in AD 453 who incorrectly carved the name of Paul on the Chalice and not clerics in AD 698.

Arthur would also have had no axe to grind over the use of Latin, unlike the monks who were at loggerheads with Rome over the dating of Easter and the structure of the Church. He was no educated scholar and therefore more likely to make grammatical errors.

And the carving of the names on the cup is rough and crude (plate 23b) as though it has been done with the end of nail—an instrument intimately associated with the Crucifixion of Christ. It is patently clear that whoever carved the cup wished to convey the fact that they did not possess the skill of whoever manufactured it. But whoever it was, they knew it was the Holy Grail and engraved it to let others know.

The Secrets of the Dragons

The engraving has more to say; it continues in loops around the solar-crosses and beneath the handle escutcheons taking the shape of two conjoined dragonheads (figure 52). This 'mark of the Grail'—two anthropo-

1970 report. The stud is also seen to have been missing from the earliest known photograph of the chalice, taken by Margaret Stokes, who drew the illustrations for the Dunraven report in 1874. There is no evidence to suggest that this missing stud was ever fitted.

The Meaning of the Missing Stud

The missing stud raises a question: were there meant to be eleven studs in the bowl girdle or twelve? The total number of pieces had already been established as 354 (representing the 354-day Druidic calendar). These two new numbers of 11 and 12 become significant when considering the length of the solar year: $354 + 11 = 365$ and $354 + 12 = 366$. There are either 365 days in a solar year or 366, in a solar leap year, confirming that the 354 pieces must refer to the number of days in a year—and that the cup must have been made by Celts around the time of Christ. It also confirms that one of the twelve rim studs was deliberately left out, in common with the practise used by ancient civilizations, to draw attention to encoded information and also to prophesy the betrayal of Jesus by Judas Iscariot.

The Mystery of the Script

Below each of the studs is carved the name of one of the twelve Apostles. As noted earlier, the names are written in insular majuscule script, persuading experts that the cup was engraved by monks at Lindisfarne. But the names of the Apostles in the Lindisfarne Gospels are written in Latinised Greek whereas on the chalice they appear in Latin. Lindisfarne was established by the Irish monk St Aidan, who, like St Patrick, preferred not to speak Latin [Patrick preferred his Celtic Mayo-Irish]. If the chalice was engraved by the monks of Lindisfarne, why did they not use the same language and convention on the chalice as they used in the Lindisfarne Gospels? Why use Latin on the cup and Latinised Greek in the Lindisfarne Gospels?

The Mystery of the Names

The twelve names as they appear on the bowl also raise questions. The name of Judas Iscariot, the so-called Disciple who betrayed Jesus, is missing, which is understandable. But the name of the Apostle who replaced him, Mathius, is not included. If the monks of Lindisfarne had engraved the cup, they would have known that Mathius had replaced Judas—given that the Lindisfarne Gospels are based on the Latin Vulgate version of the Bible which contains the Acts of the Apostles naming Mathius as the replacement. Instead, the twelfth name on the chalice is that of St. Paul, the one-time Roman Saul, who preached around the Mediterranean during Roman times. The earliest known version of the New Testament comes from the early *Peshitto* manuscript precisely dated as being written in AD 464, after the death of King Arthur. King Arthur, therefore, who died in around AD 450, would not have known that Mathius had replaced Judas. Arthur, however, having lived through the Roman occupation of Britain, would have been aware of the works of St. Paul—the favourite of the Romans after the time of Constantine—and therefore would more likely have believed that the popular Paul had taken the role of the twelfth Apostle.

The Mystery of the Grammar

A linguistic scholar has pointed out that the names contain grammatical errors: ten names appear in the possessive sense but two—the Latin versions of Tatheus and Simon—appear in the nominative. St Aidan may not have favoured Latin but he was a scholar, as the Lindisfarne Gospels testify. It is unlikely therefore that educated clerics engraved the chalice. If clerics did not engrave the chalice, then who did?

The Secrets of the Carving

The incorrect names of the Apostles support the view that it was Arthur in AD 453 who incorrectly carved the name of Paul on the chalice and not clerics in AD 698.

Arthur would also have had no axe to grind over the use of Latin, unlike the monks, who were at loggerheads with Rome over the dating

morphic dragon-angels—also appears either side of the Grail shown in the fifteenth-century manuscript (plate 19). Two dragonheads are known, from archaeological evidence, to represent Christ and the Crucifixion, further supporting the association of the chalice with the event. Figure 53 shows an example of a Tau Cross featuring a scene of the Crucifixion with Christ on the cross together with Mary and St John inside a solar-cross envelope inside the conjoined belly of two dragons.

Following the Crucifixion, the Greek letter 'T', or Tau, was associated with the cross. The dragons represent sacrifice, after the ancient custom of Silene where the first born of every family was (legend has it) sacrificed to a dragon that lived in a swamp. Jesus was, likewise, sacrificed on the cross.

Figure 54a shows another example of a Tau Cross, this time with Mary and the baby Jesus inside the circular Sun, which carries magnetic loops around the perimeter, again inside the belly of two conjoined dragons. Venus appears either side of the Sun, as a small white circular stud. Figure 54b shows the picture on the sarcophagus lid of Lord Pacal (the Amazing Lid of Palenque) and figure 54c shows a detailed section of the lid featuring a Tau Cross, meaning that Lord Pacal is also associated with the Tau Cross and the Crucifixion of Jesus.

According to Malory, the staff carried by the time-travelling magician Merlin was crowned with a Tau cross identical to the one in figure 53. Merlin was hence aware of the meaning of the Tau Cross and its association with Christ and must have therefore instructed Arthur to carve the dragons on the Holy Grail to authenticate its provenance.

No one but Arthur or his Knights would have engraved two conjoined dragons on the chalice to acknowledge the Crucifixion of Jesus and celebrate the cup's discovery because no-one but Arthur or his Knights have been featured worshipping the Grail flanked by two dragons. And no one but Arthur or his Knights have been featured at the Round Table worshipping the Grail radiating light—from the Quartz crystal in the foot-cone.

The Secrets of the Maze-like Pattern

Another engraving, in the same style as the rest, circumscribes the Upper foot-cone, just beneath the dragonheads. By now the reader will be fa-

of Easter and the structure of the Church. He was no educated scholar and therefore more likely to make grammatical errors.

And the carving of the names on the cup is rough and crude (plate 23b) as though it has been done with the end of nail—an instrument intimately associated with the Crucifixion of Christ. It is patently clear that whoever carved the cup wished to convey the fact that they did not possess the skill of whoever manufactured it. But whoever it was, they knew it was the Holy Grail and engraved it to let others know.

The Secrets of the Dragons

The engraving has more to say; it continues in loops around the solar crosses and beneath the handle escutcheons taking the shape of two conjoined dragon heads (figure 52). This 'mark of the Grail'—two anthropomorphic dragon-angels—also appears either side of the Grail shown in the fifteenth-century manuscript (plate 19). Two dragon heads are known, from archaeological evidence, to represent Christ and the Crucifixion, further supporting the association of the chalice with the event. Figure 53 shows an example of a tau cross featuring a scene of the Crucifixion with Christ on the cross together with Mary and St John inside a solar cross envelope inside the conjoined belly of two dragons.

Following the Crucifixion, the Greek letter *t*, or tau, was associated with the cross. The dragons represent sacrifice, after the ancient custom of Silene where the firstborn of every family was (legend has it) sacrificed to a dragon that lived in a swamp. Jesus was, likewise, sacrificed on the cross.

Figure 54a shows another example of a tau cross, this time with Mary and the baby Jesus inside the circular Sun, which carries magnetic loops around the perimeter, again inside the belly of two conjoined dragons. Venus appears either side of the Sun, as a small white circular stud. Figure 54b shows the lid of Lord Pacal at Palenque and figure 54c shows a detailed section of the lid featuring a tau cross, meaning that Lord Pacal is also associated with the tau cross and the Crucifixion of Jesus.

Tau Cross dragon heads



Figure 52. The poor quality hand-sketched engraving, detailing the names of the Apostles, continues around the chalice and terminates with a picture of two conjoined dragonheads [shown upside down in this illustration] beneath each of the handle escutcheons. A similar depiction [of two anthropomorphic dragon-angels] also appears either side of the Grail shown in the fifteenth-century manuscript (plate 19). Moreover, two dragonheads are known, from archaeological evidence, to represent Christ and the Crucifixion, further supporting the association of the chalice with the event.

Tau Cross (showing dragon heads)



Figure 53. Tau cross, showing a scene of the Crucifixion with Christ on the cross together with Mary and St John inside a solar-cross envelope, all inside the conjoined belly of two dragons (from a Greek ivory staff, Tarascon, eighteenth-century). Following the Crucifixion, the Greek letter T, or Tau, was associated with the cross. The dragons represent sacrifice, after the ancient custom of Silene where the first born of every family was (legend has it) sacrificed to a dragon that lived in a swamp. Hence the association with Jesus who was, likewise, sacrificed on the cross. The staff carried by the time-travelling magician Merlin [counsellor and spiritual guide of King Arthur] was crowned with a Tau cross identical to this one. Merlin was hence aware of the meaning of the Tau Cross and its association with Christ and must have, therefore, instructed Arthur to carve the dragons on the Holy Grail to authenticate its provenance.

Tau cross dragon heads

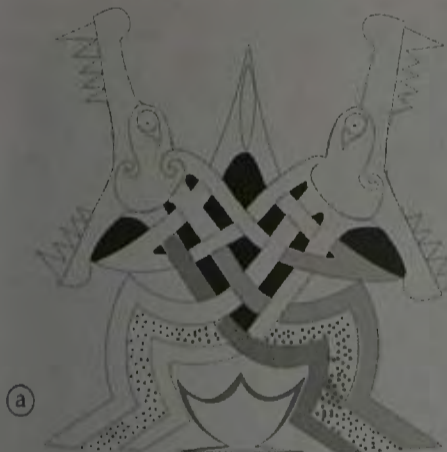

Figure 52. The poor-quality, hand-sketched engraving, detailing the names of the Apostles, continues around the chalice and terminates with a picture of two conjoined dragon heads [shown upside down in this illustration] beneath each of the handle escutcheons. A similar depiction [of two anthropomorphic dragon-angels] also appears either side of the Grail shown in the fifteenth-century manuscript (plate 19). Moreover, two dragon heads are known, from archaeological evidence, to represent Christ and the Crucifixion, further supporting the association of the chalice with the event.

Tau cross (showing dragon heads)



Figure 53. Tau cross, showing a scene of the Crucifixion with Christ on the cross together with Mary and St John inside a solar-cross envelope, all inside the conjoined belly of two dragons (from a Greek ivory staff, Tarascon, eighteenth century). Following the Crucifixion, the Greek letter *t*, or tau, was associated with the cross. The dragons represent sacrifice, after the ancient custom of Silene where the firstborn of every family was (legend has it) sacrificed to a dragon that lived in a swamp. Hence the association with Jesus who was, likewise, sacrificed on the cross. The staff carried by the time-travelling magician Merlin [counsellor and spiritual guide of King Arthur] was crowned with a Tau cross identical to this one. Merlin was hence aware of the meaning of the Tau cross and its association with Christ and must have, therefore, instructed Arthur to carve the dragons on the Holy Grail to authenticate its provenance.

Tau cross dragon heads



Figure 52. The poor-quality, hand-sketched engraving, detailing the names of the Apostles, continues around the chalice and terminates with a picture of two conjoined dragon heads [shown upside down in this illustration] beneath each of the handle escutcheons. A similar depiction [of two anthropomorphic dragon-angels] also appears either side of the Grail shown in the fifteenth-century manuscript (plate 19). Moreover, two dragon heads are known, from archaeological evidence, to represent Christ and the Crucifixion, further supporting the association of the chalice with the event.

b

Tau cross (showing dragon heads)



Figure 53. Tau cross, showing a scene of the Crucifixion with Christ on the cross together with Mary and St John inside a solar-cross envelope, all inside the conjoined belly of two dragons (from a Greek ivory staff, Tarascon, eighteenth century). Following the Crucifixion, the Greek letter τ , or tau, was associated with the cross. The dragons represent sacrifice, after the ancient custom of Silene where the firstborn of every family was (legend has it) sacrificed to a dragon that lived in a swamp. Hence the association with Jesus who was, likewise, sacrificed on the cross. The staff carried by the time-travelling magician Merlin [counsellor and spiritual guide of King Arthur] was crowned with a Tau cross identical to this one. Merlin was hence aware of the meaning of the Tau cross and its association with Christ and must have, therefore, instructed Arthur to carve the dragons on the Holy Grail to authenticate its provenance.

The Secret of the Conjoined Dragons (II)

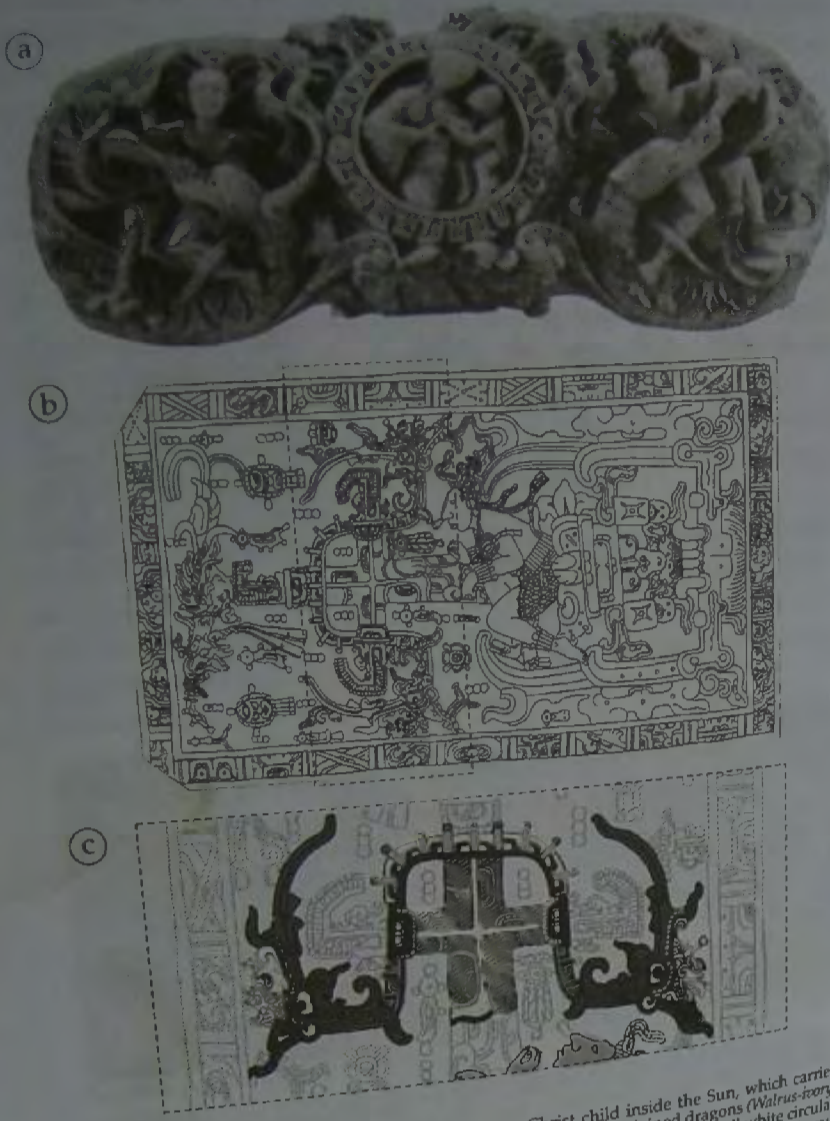

Figure 54. (a) Tau cross, showing Mary with the Christ child inside the Sun, which carries magnetic loops around the perimeter, inside the belly of two conjoined dragons (Walrus-ivory, English, mid-twelfth-century). Venus appears either side of the Sun, as a small white circular stud. (b) The Lid of Palenque, the 5-tonne (4.92-ton) limestone lid that covers the sarcophagus of Lord Pacal in his tomb at Palenque. (c) Detail from the lid showing a Tau Cross, meaning that Lord Pacal was also associated with the Tau Cross and the Crucifixion of Jesus. The centre cross is covered in magnetic loops, sunspot loops, suggesting that Lord Pacal, like Jesus, was the Sun on Earth.

The Secret of the Conjoined Dragons (II)

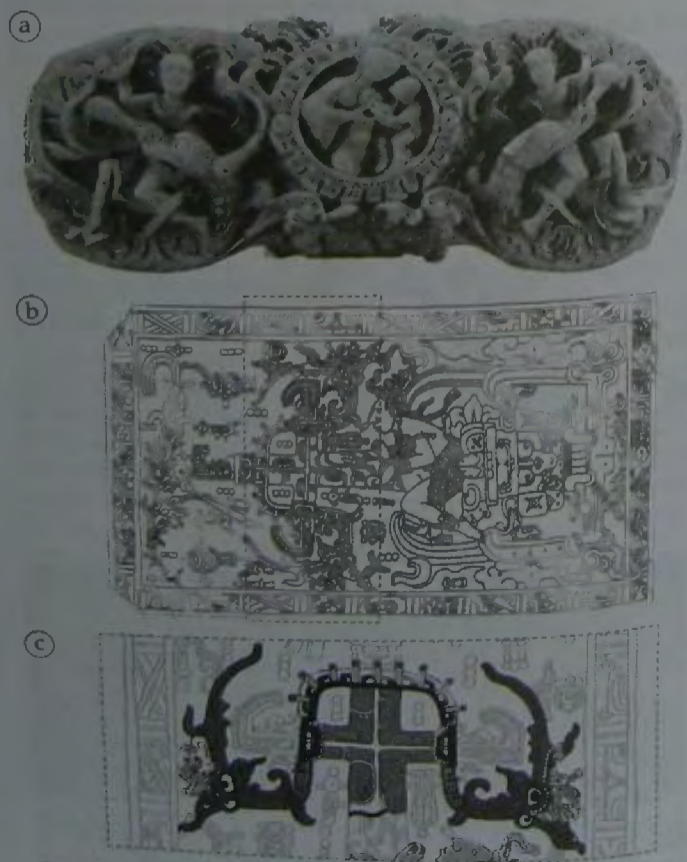

Figure 54. (a) Tau cross, showing Mary with the Christ child inside the Sun, which carries magnetic loops around the perimeter, inside the belly of two conjoined dragons (Walrus-ivory, English, mid-twelfth-century). Venus appears either side of the Sun, as a small white circular stud. (b) The Lid of Palenque, the 5-tonne (4.92-ton) limestone lid that covers the sarcophagus of Lord Pacal in his tomb at Palenque. (c) Detail from the lid showing a tau cross, meaning that Lord Pacal was also associated with the Tau Cross and the Crucifixion of Jesus. The centre cross is covered in magnetic loops, sunspot loops, suggesting that Lord Pacal, like Jesus, was the Sun on Earth.

miliar with the pattern? It is the same pattern which is carved on the Hallstatt scabbard (figure 4, alongside the twins (Venus—Jesus) and the reverse-swastika of the Hallstatt Celts of 600 BC). It is also the same pattern worn by Viracocha, on his tunic, on the Viracocha Vase of Tiahuanaco (figure 56). The vase dates from around AD 500 and was found at the site of Tiahuanaco, on the shore of Lake Titicaca, in today's Bolivia. The pattern therefore must have been in use during the intervening period [between 600 BC and AD 500], around AD 26, the time of the Crucifixion.

As discussed earlier, the sun shield of Monte Alban transformer (plate 2) contains secret pictures of the Gateway of the Sun at Tiahuanaco inside the Star of David, the geometric symbol of Judaism. The bas relief carving of Viracocha from the lintel of the Gateway also carries the same maze-like pattern in the ring around his head. And the sun shield (plate 3) shows a picture of Lord Pacal regurgitating a pearl inside a vesica pisces, the geometric symbol of Christianity. And consider a passage from Revelation in the Bible;

I saw an angel come down from Heaven...and a rainbow was on his head and his face was, as it were, the Sun...and he set his right foot upon the sea and his left foot upon the earth. Revelation X.

In isolation, it may seem as though St John was suffering delusions as he wrote Revelation on the island of Patmos in the Mediterranean, at least until we compare the words from Revelation to Plate 5e, which shows a reconstruction of Viracocha Pachacamac [from the museum of Archaeology in Lima, Peru] made by archaeologists using treasures found in his tomb at Sipan. It shows an angel (with a golden halo above his head) with a rainbow on his head and the Sun, as it were [a gold bat mask], across his face. His name is Viracocha, foam of the sea, who would, as his name suggests, stand with one foot in the sand and the other in the sea.

The pattern that circumscribes the foot-cone of the Chalice, the sun shield of Monte Alban and the pattern from Viracocha's tunic on the Viracocha vase all reveal that Jesus the Jew reincarnated as Viracocha and that Viracocha reincarnated as Lord Pacal.

According to Malory, the staff carried by the time-travelling magician Merlin was crowned with a tau cross identical to the one in figure 53. Merlin was hence aware of the meaning of the tau cross and its association with Christ and must have therefore instructed Arthur to carve the dragons on the Holy Grail to authenticate its provenance.

No one but Arthur or his knights would have engraved two conjoined dragons on the chalice to acknowledge the Crucifixion of Jesus and celebrate the cup's discovery because no one but Arthur or his knights have been featured worshipping the Grail flanked by two dragons. And no one but Arthur or his knights have been featured at the Round Table worshipping the Grail radiating light—from the quartz crystal in the foot-cone.

The Secrets of the Chalice Engraving

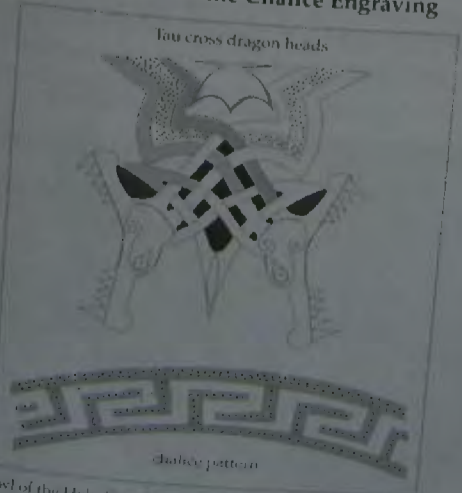

Figure 55. The bowl of the Holy Grail is engraved with two dragon heads, beneath each of the handle escutcheons. The foot cone is engraved with a maze-like pattern, identical to one found on the Viracocha vase of Tiahuanaco.

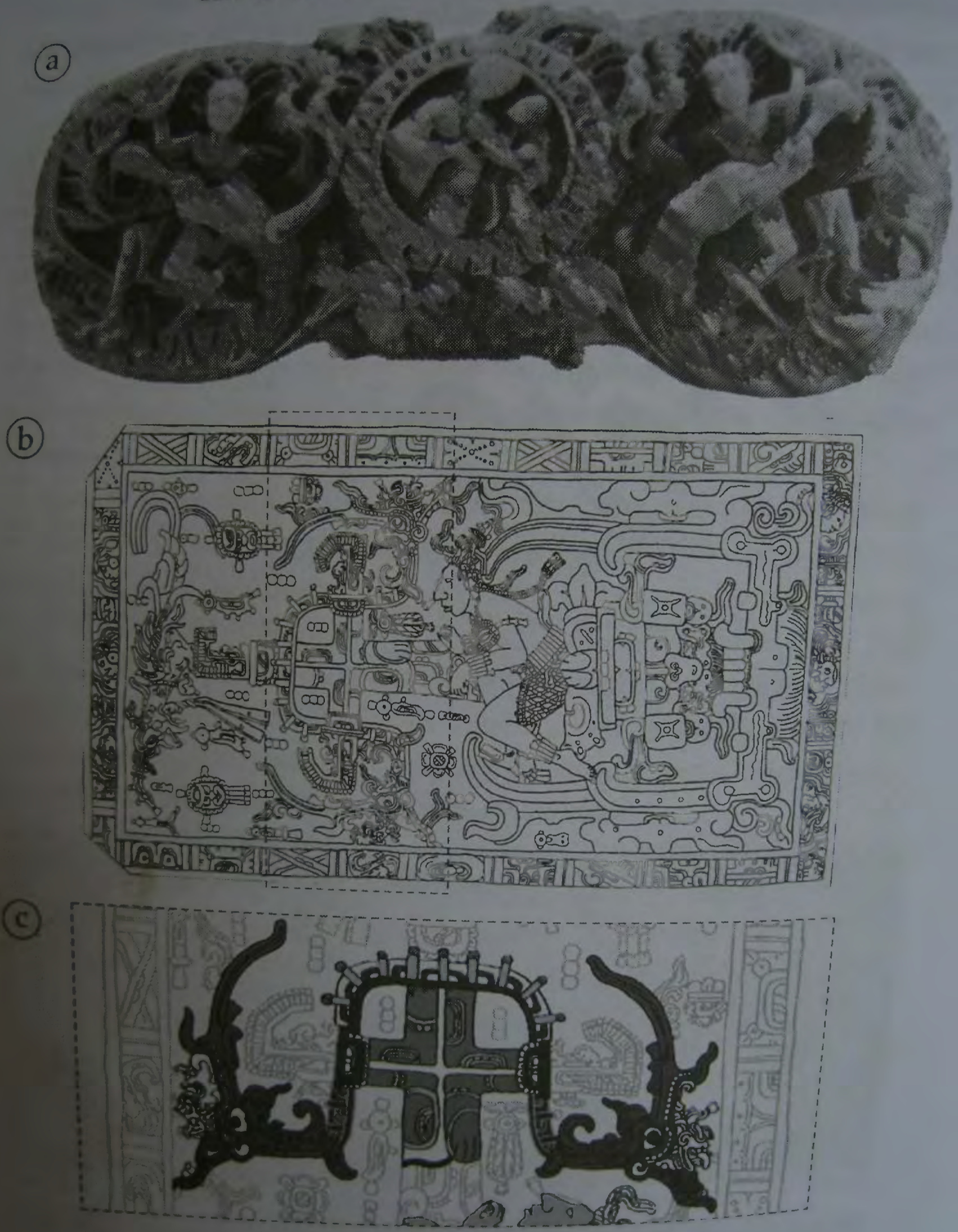

Figure 54. (a) Tau cross, showing Mary with the Christ child inside the Sun, which carries magnetic loops around the perimeter, inside the belly of two conjoined dragons (Walrus-ivory, English, mid-twelfth-century). Venus appears either side of the Sun, as a small white circular stud. (b) The Lid of Palenque, the 5-tonne (4.92-ton) limestone lid that covers the sarcophagus of Lord Pacal in his tomb at Palenque. (c) Detail from the lid showing a Tau Cross, meaning that Lord Pacal was also associated with the Tau Cross and the Crucifixion of Jesus. The centre cross is covered in magnetic loops, sunspot loops, suggesting that Lord Pacal, like Jesus, was the Sun on Earth.

The Secret of the Conjoined Dragons (II)

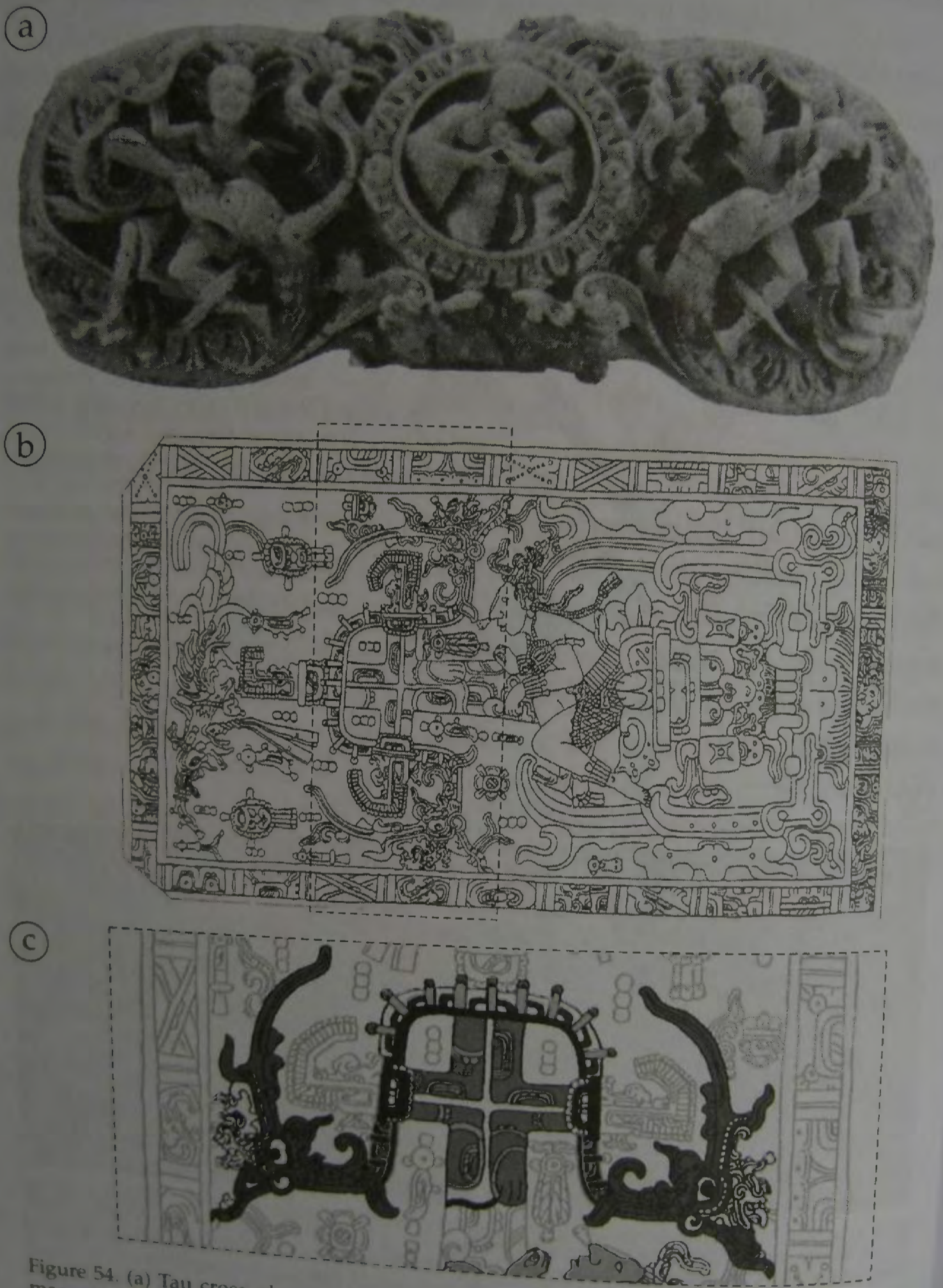

Figure 54. (a) Tau cross, showing Mary with the Christ child inside the Sun, which carries magnetic loops around the perimeter, inside the belly of two conjoined dragons (Walrus-ivory, English, mid-twelfth century). Venus appears either side of the Sun, as a small white circular stud. (b) The Lid of Palenque, the 5-tonne (4.92-ton) limestone lid that covers the sarcophagus of Lord Pacal in his tomb at Palenque. (c) Detail from the lid showing a tau cross, meaning that Lord Pacal was also associated with the tau cross and the Crucifixion of Jesus. The centre cross is covered in magnetic loops, sunspot loops, suggesting that Lord Pacal, like Jesus, was the Sun on Earth.

Figure
the har
found c

SONS

the
steps
of
ico,
the

The Secrets of the Chalice Engraving

Tau cross dragon heads

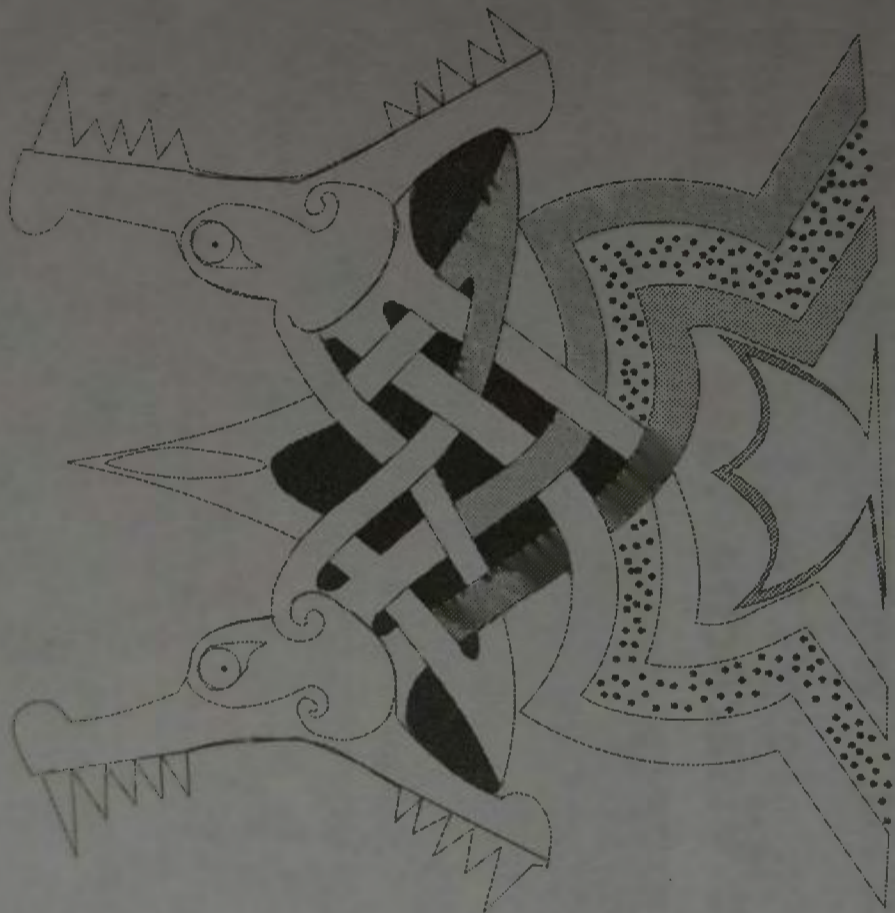

chalice pattern

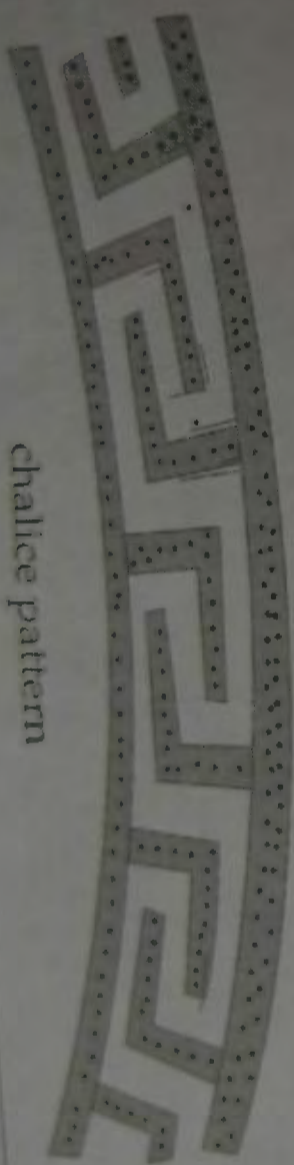
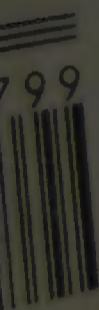

Figure 55. The bowl of the Holy Grail is engraved with two dragon heads, beneath each of the handle escutcheons. The foot-cone is engraved with a maze-like pattern, identical to one found on the Viracocha vase of Tiahuanaco.

which carries
(Malrus-ivory,
white circular
the sarcophagus
ss, meaning that
The centre cross
ke Jesus, was the



The Secrets of the Chalice Engraving

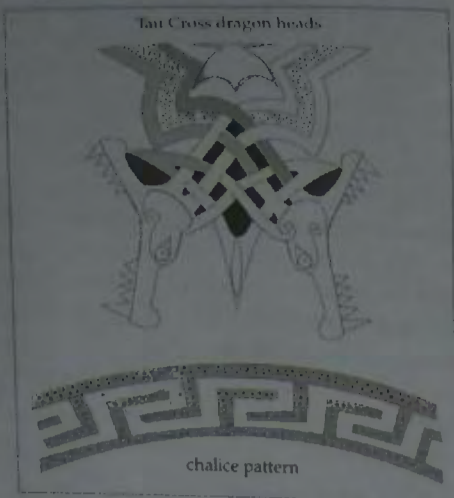

Figure 55. The bowl of the Holy Grail is engraved with two dragonheads, beneath each of the handle escutcheons. The foot-cone is engraved with a maze-like pattern, identical to one found on the Viracocha vase of Tiahuanaco.

The Viracocha Vase of Tiahuanaco

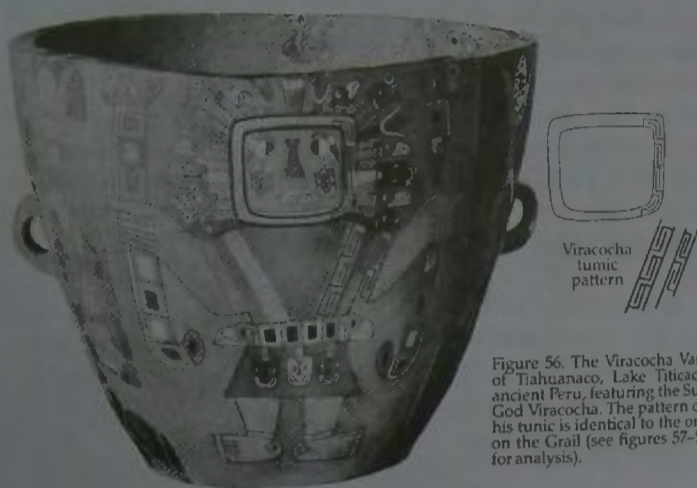

Figure 56. The Viracocha Vase of Tiahuanaco, Lake Titicaca, ancient Peru, featuring the Sun God Viracocha. The pattern on his tunic is identical to the one on the Grail (see figures 57-59 for analysis).

Decoding the Maze-like Pattern

The first thing we notice about the maze-like pattern on the tunic of Viracocha is that it is tilted by 23.5° to the vertical (figure 57a), the same angle as the tilt of the Earth on its axis. Appendix 1 shows that the Viracocha bas relief found on the lintel of the Gateway of the Sun is actually a Maya Transformer which tells an account of how the Earth has been destroyed on four previous occasions by solar inspired magnetic reversals that caused the Earth to tilt on its axis. The decoding of the Viracocha transformer also confirms that the same person who encoded information into the Amazing Lid of Palenque, and into the sun shield of Monte Alban, used the same Maya Transformer technique to encode information into the Viracocha bas relief at Tiahuanaco. Given that Viracocha lived in Peru in around AD 500 and that Lord Pacal lived in Mexico in around AD 750, it could hardly have been the same physical person (unless he lived for more than 250 years) and therefore the reincarnation hypothesis is the only one that fits. Viracocha, who used his Transformer encoding technique on the bas relief of the Gateway of the Sun (Appendix 1) must have carried the technique to Mexico c. AD 750, in the guise of Lord Pacal.

The Viracocha tunic pattern will now facilitate decoding of the upper-foot-girdle engraving; figures 57bi and bii shows the Viracocha pattern tilted counter-clockwise by 23.5° to facilitate analysis. The first thing we notice is that pattern figure 57bi differs from the pattern in figure 57bii, they are mirror images.

Pattern figure 57bi can now be decoded by following the path through the maze-like pattern and, by using arrows, to show the route covered (figure 57c). The arrows reveal the number 666, the number of the beast from Revelation.

But a closer look at the chalice engraving shows that the pattern is identical to the mirror image pattern, figure 58aii, which does not yield the number 6. Neither does it reveal the number 9, which is what you might expect the mirror image to produce. Viewing the chalice engraving from above (figure 59a) in fact reveals nothing of any numerical significance at all? At least it reveals nothing—until we view the chalice maze-like engraving from beneath the foot-cone.

The Secrets of the Maze-like Pattern

Another engraving, in the same style as the rest, circumscribes the upper foot-cone, just beneath the dragon heads. By now the reader will be familiar with the pattern. It is the same pattern which is carved on the Hallstatt scabbard (figure 4, alongside the twins [Venus—Jesus] and the reverse swastika of the Hallstatt Celts of 600 BC). It is also the same pattern worn by Viracocha, on his tunic, on the Viracocha vase of Tiahuanaco (figure 56). The vase dates from around AD 500 and was found at the site of Tiahuanaco, on the shore of Lake Titicaca, in today's Bolivia. The pattern therefore must have been in use during the intervening period [between 600 BC and AD 500], around AD 26, the time of the Crucifixion.

As discussed earlier, the sun shield of Monte Alban transformer (plate 2) contains secret pictures of the Gateway of the Sun at Tiahuanaco inside the Star of David, the geometric symbol of Judaism. The bas-relief carving of Viracocha from the lintel of the gateway also carries the same maze-like pattern in the ring around his head. And the sun shield (plate 3c) shows a picture of Lord Pacal regurgitating a

The Viracocha Vase of Tiahuanaco



Figure 56. The Viracocha vase of Tiahuanaco, Lake Titicaca, ancient Peru, featuring the Sun God Viracocha. The pattern on his tunic is identical to the one on the Grail (see figures 57-59 for analysis).

pearl inside a vesica pisces, the geometric symbol of Christianity. And consider a passage from Revelation in the Bible:

I saw an angel come down from Heaven . . . and a rainbow was on his head and his face was, as it were, the Sun . . . and he set his right foot upon the sea and his left foot upon the earth. (Revelation X)

In isolation, it may seem as though St John was suffering delusions as he wrote Revelation on the island of Patmos in the Mediterranean, at least until we compare the words from Revelation to plate 5e, which shows a reconstruction of Viracocha Pachacamac [from the Museum of Archaeology in Lima, Peru] made by archaeologists using treasures found in his tomb at Sipan. It shows an angel (with a golden halo above his head) with a rainbow on his head and the Sun, as it were [a gold bat mask], across his face. His name is Viracocha, foam of the sea, who would, as his name suggests, stand with one foot in the sand and the other in the sea.

The pattern that circumscribes the foot-cone of the chalice, the sun shield of Monte Alban and the pattern from Viracocha's tunic on the Viracocha vase all reveal that Jesus the Jew reincarnated as Viracocha and that Viracocha reincarnated as Lord Pacal.

Decoding the Maze-like Pattern

The first thing we notice about the maze-like pattern on the tunic of Viracocha is that it is tilted by 23.5° to the vertical (figure 57ai), the same angle as the tilt of the Earth on its axis. Appendix 1 shows that the Viracocha bas-relief found on the lintel of the Gateway of the Sun is actually a Mayan transformer that tells an account of how the Earth has been destroyed on four previous occasions by solar-inspired magnetic reversals that caused the Earth to tilt on its axis. The decoding of the Viracocha transformer also confirms that the same person who encoded information into the Amazing Lid of Palenque, and the sun shield of Monte Alban, used the same Mayan transformer technique to encode information into the Viracocha bas-relief at Tiahuanaco. Given that Viracocha lived in Peru in around AD 500 and that Lord Pacal lived in Mexico in around AD 750, it could hardly have been the same

The Viracocha Vase of Tiahuanaco

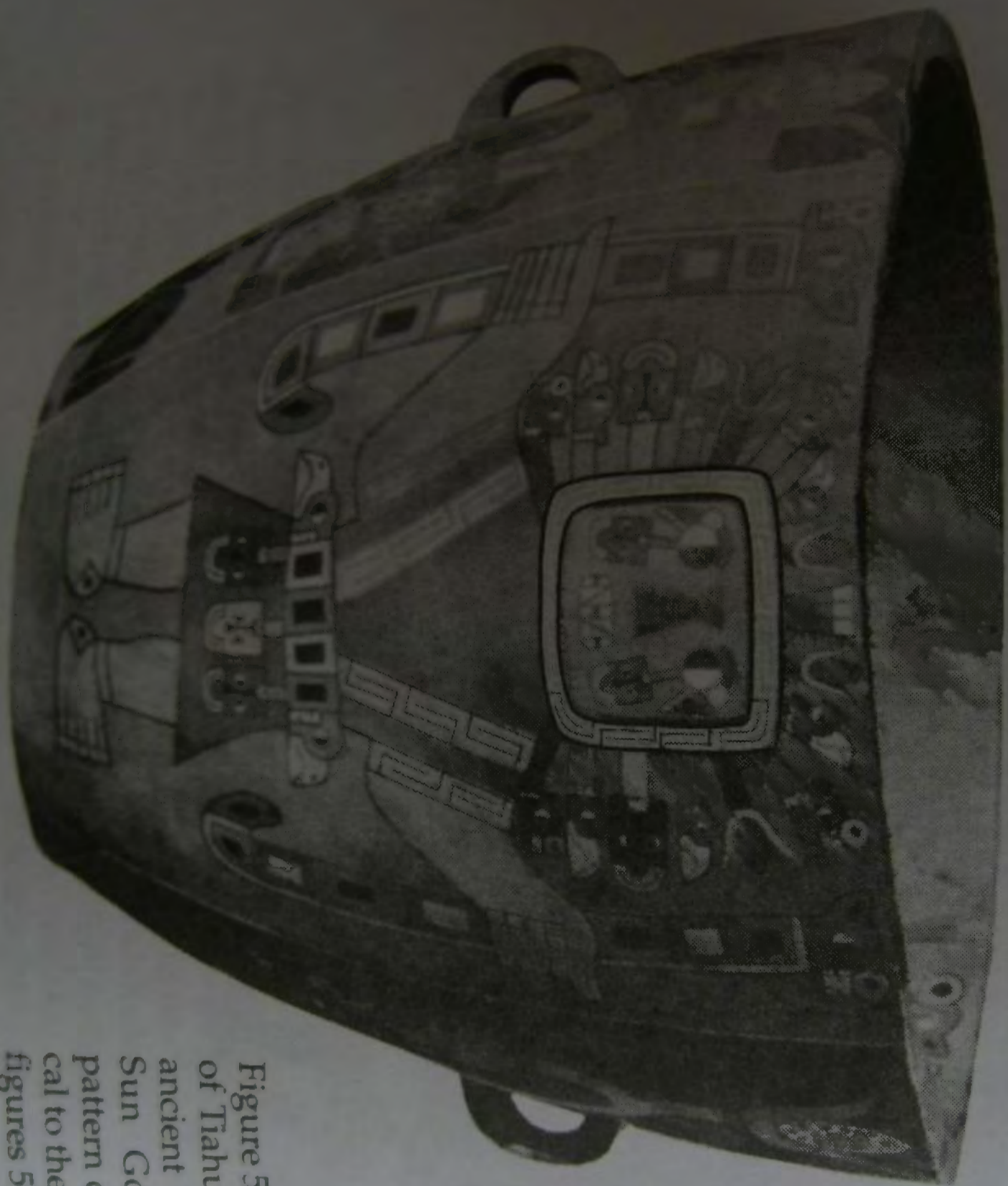

158

Figure 56. The Viracocha vase of Tiahuanaco, Lake Titicaca, ancient Peru, featuring the Sun God Viracocha. The pattern on his tunic is identical to the one on the Grail (see figures 57-59 for analysis).

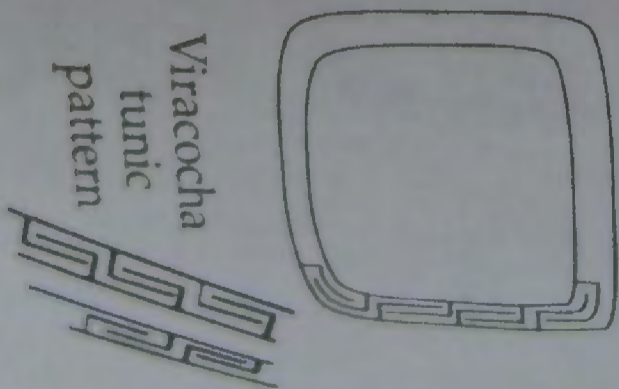

Dec
The
Virac
same
the W
is act
has b
netic
of the
encod
shield
encode
that Vi
lived in

The Secrets of the Chalice Engraving

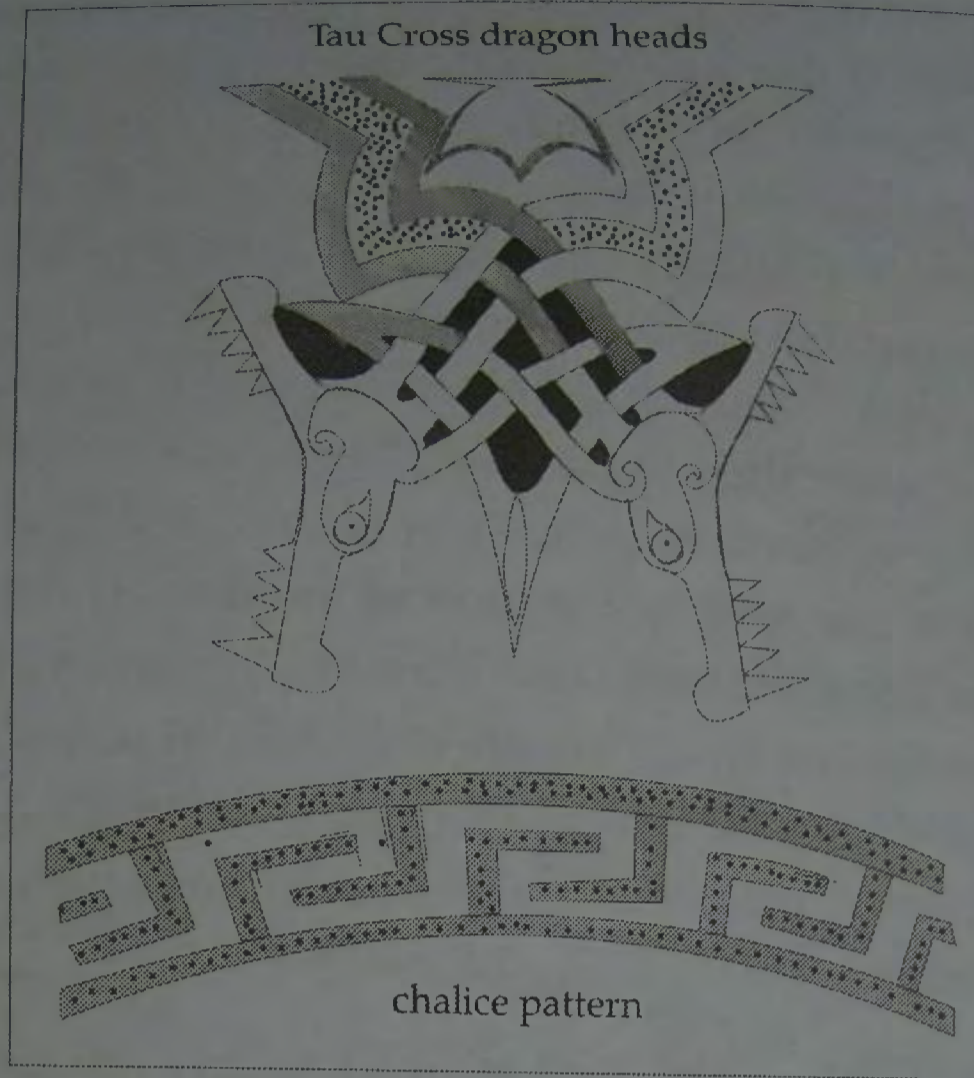

Figure 55. The bowl of the Holy Grail is engraved with two dragonheads, beneath each of the handle escutcheons. The foot-cone is engraved with a maze-like pattern, identical to one found on the Viracocha vase of Tiahuanaco.

The Viracocha Vase of Tiahuanaco

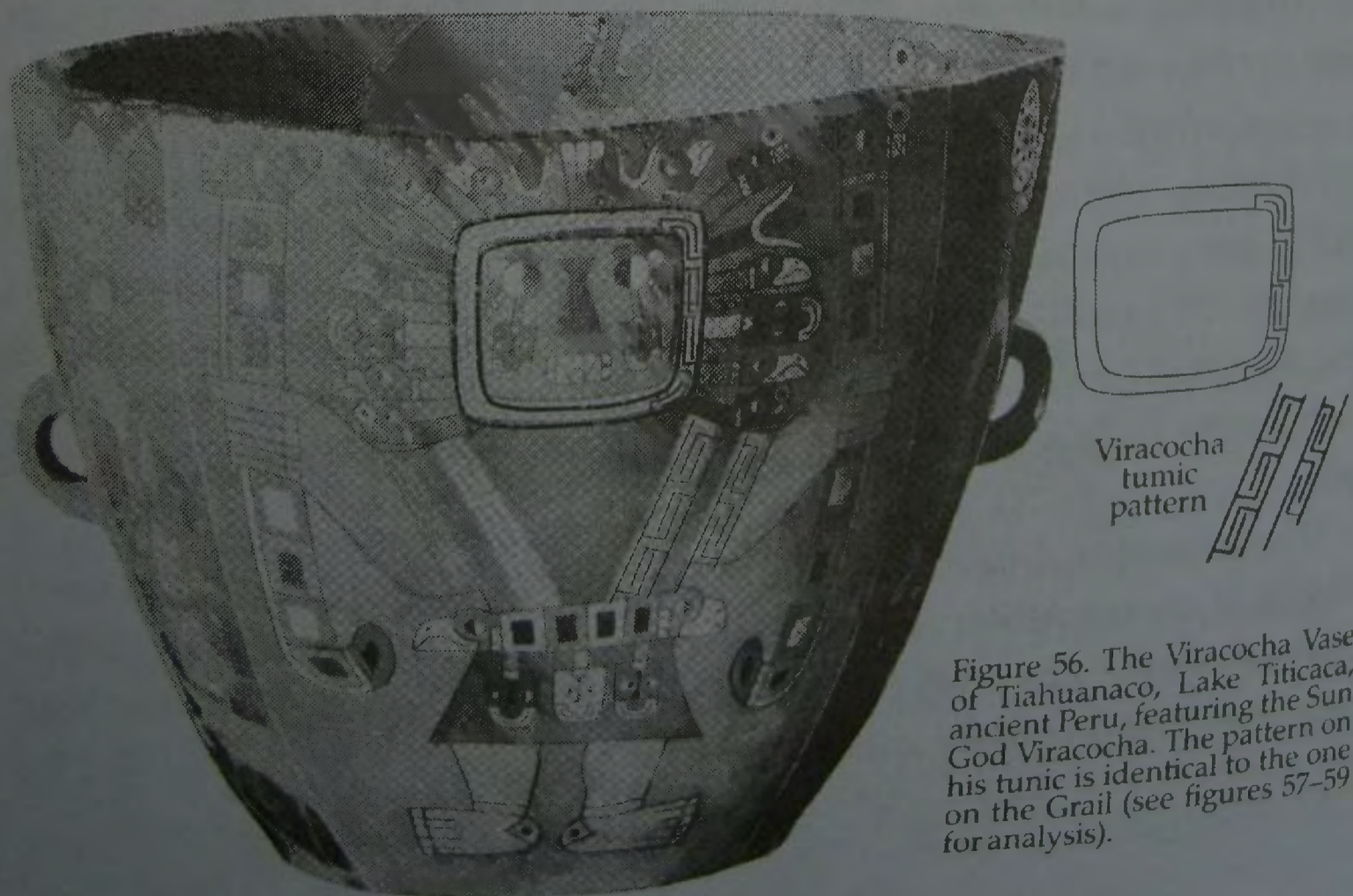

Figure 56. The Viracocha Vase of Tiahuanaco, Lake Titicaca, ancient Peru, featuring the Sun God Viracocha. The pattern on his tunic is identical to the one on the Grail (see figures 57-59 for analysis).

physical person (unless he lived for more than 250 years) and therefore the reincarnation hypothesis is the only one that fits. Viracocha, who used his transformer encoding technique on the bas-relief of the Gateway of the Sun (appendix 1), must have carried the technique to Mexico c. AD 750, in the guise of Lord Pacal.

The Viracocha tunic pattern will now facilitate decoding of the upper foot girdle engraving; figures 57bi and bii show the Viracocha pattern tilted counterclockwise by 23.5° to facilitate analysis. The first thing we notice is that pattern figure 57bi differs from the pattern in figure 57bii: they are mirror images.

Pattern figure 57bi can now be decoded by following the path through the maze-like pattern and, by using arrows, to show the route covered (figure 57c). The arrows reveal the number 666, the number of the beast from Revelation.

But a closer look at the chalice engraving shows that the pattern is identical to the mirror-image pattern, figure 58aii, which does not yield the number 6. Nor does it reveal the number 9, which is what you might expect the mirror image to produce. Viewing the chalice engraving from above (figure 59a) in fact reveals nothing of any numerical significance at all. At least it reveals nothing until we view the chalice maze-like engraving from beneath the foot-cone.

The Secrets of the Quartz Crystal

When we lift the chalice and view the *virtual* pattern, the numbers 99999... now appear (figure 59b) [if it were possible to see through the metal] which tells us that the engraving is intended to be viewed from below, upwards towards Heaven. But it still comes as a surprise that when the pattern is viewed from above the 666 of the physical world does not appear. So, how can 666 be derived from the maze-like pattern around the foot-cone?

The only way to convert the number 666 into the number 999 using mirror imaging is shown in figure 59c. Firstly take the number 666. Then take the *horizontal* mirror image, as shown by the arrow. Then take the *vertical* mirror image of the result, again shown by an arrow. The same technique can again be used to convert 999 into 666, once again using arrows. What results is a rotating arrow network.

Decoding the Viracocha Pattern (I)

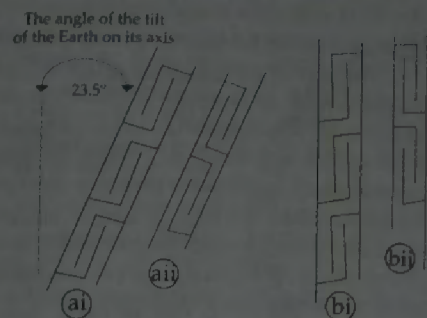
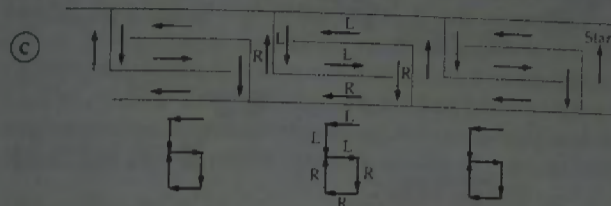

Figure 57. (ai) and (aii) The angle of the maze-like pattern on Viracocha's tunic is 23.5° to the vertical, representing the tilt of the Earth on its axis (see appendix 4, The Viracocha Transformer of Tiahuanaco). (bi) and (bii) The maze-like pattern corrected by 23.5° to facilitate analysis.

Decoding the Viracocha Pattern (II)



The Viracocha pattern (ai) contains secret information. To follow the path through the maze, the initiate must turn left, left, and then left again (L, L, L), then right, right and right (R, R, R) again. When this instruction is followed—and laid out using arrows (as shown)—the numbers 666 are revealed. The same number, associated with a dragon, is given in the Bible when describing a beast that rises from the sea...

... the dragon gave him his power and his seat and great authority... here is wisdom, let him that hath understanding count the number of the beast, for it is the number of a man, and his number is six hundred three score and six [666] Revelation XIII, 1-18

Decoding the Viracocha Pattern (III)

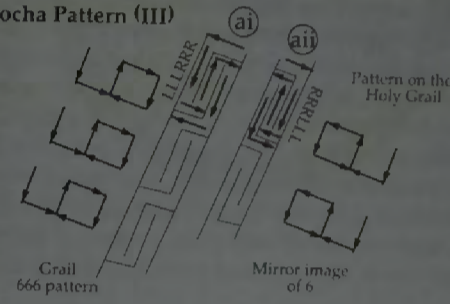

Figure 58. (ai) The Viracocha pattern translates into the numbers 666. However, (aia) shows that the adjacent pattern—the identical pattern to that on the Grail—does not yield the number 6. Nor does it yield the number 9. However, it does reveal the mirror image of the number 6 (associating the pattern with the soul).

Decoding the Viracocha Pattern (I)

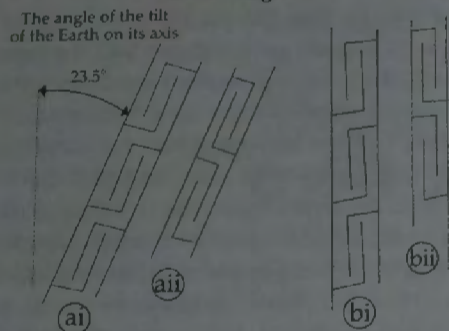
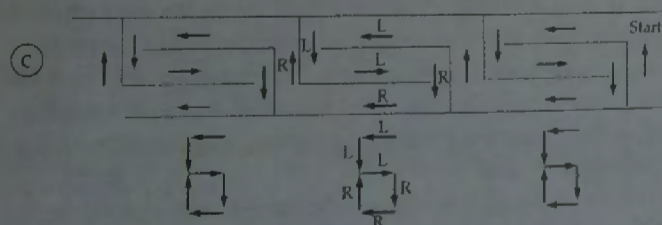

Figure 57. (ai and aii) The angle of the maze-like pattern on Viracocha's tunic is 23.5° to the vertical, representing the tilt of the Earth on its axis (see Appendix 1, the Viracocha Transformer of Tiahuanaco). (bi and bii) The maze-like pattern corrected by 23.5° to facilitate analysis.

Decoding the Viracocha Pattern (II)



The Viracocha pattern (ai) contains secret information. To follow the path through the maze the initiate must turn left, left, and then left again (L, L, L), then right, right and right (R, R, R) again. When this instruction is followed—and laid out using arrows (as shown)—the numbers 666 are revealed. The same number, associated with a dragon, is given in the Bible when describing a beast that rises from the sea...

... the dragon gave him his power and his seat and great authority... here is wisdom, let him that hath understanding count the number of the beast, for it is the number of a man, and his number is six hundred three score and six [666] Revelation XIII, 1-18.

Decoding the Viracocha Pattern (III)

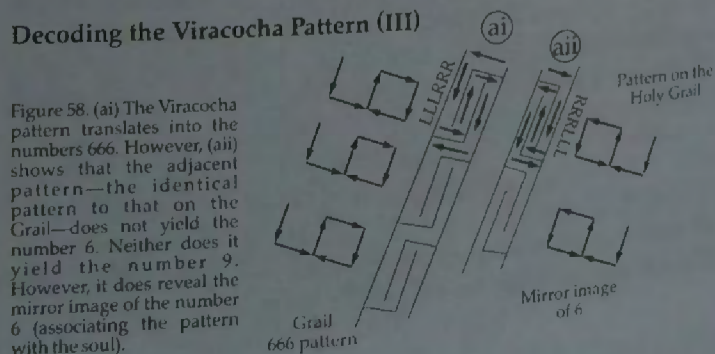

Figure 58. (ai) The Viracocha pattern translates into the numbers 666. However, (aia) shows that the adjacent pattern—the identical pattern to that on the Grail—does not yield the number 6. Neither does it yield the number 9. However, it does reveal the mirror image of the number 6 (associating the pattern with the soul).

The Secrets of the Quartz Crystal

When we lift the chalice and view the *virtual* pattern the numbers 99999... now appear (figure 59b) [if it were possible to see through the metal] which tells us that the engraving is intended to be viewed from below, upwards towards Heaven. But it still comes as a surprise that when the pattern is viewed from above the 666 of the physical world does not appear. So, how can 666 be derived from the maze-like pattern around the foot-cone?

The only way to convert the number 666 into the number 999 using mirror imaging is shown in figure 59c; firstly take the number 666. Then take the *horizontal* mirror image, as shown by the arrow. Then take the *vertical* mirror image of the result, again shown by an arrow. The same technique can again be used to convert 999 into 666, once again using arrows. What results is a rotating arrow network.

Viewed from below, this attempt [to intellectually convert 666 into 999—an attempt to convert the body into a soul] endows upon the centre crystal circulating arrows, which in turn cause the centre quartz crystal to *virtually spin*, emulating the Sun as it spins on its axis. This means that the quartz crystal must represent the Sun, confirming the proposition put forward by the Arthurian legends that the Holy Grail radiates light, as shown in plate 19—it contains within it the Sun. Only Arthur (who is shown in plate 19 worshipping the Holy Grail radiating light) could have known this and only Arthur could have carved the maze-like pattern on the upper-foot-cone to convey this information.

Amazingly, closer inspection of the Hallstatt maze-like pattern (figure 4) shows that it too contains *both* versions of the maze-like pattern, the original and the mirror image [the pattern very cleverly reverses beneath the hands of each of the twins]. Which means that whoever carved the pattern on the Hallstatt scabbard understood the same knowledge as whoever carved *both* patterns on the tunic of Viracocha 1,100 years later. Which in turn means that the Hallstatt Celts acquired their super-knowledge from a Supergod, who must have been the King of Hochdorf (whose number was 999) who died in around 550 BC.

The Secrets of the Swastika Panels

But surely, if the chalice was engraved 450 years after it was made, it

physical person (unless he lived for more than 250 years) and therefore the reincarnation hypothesis is the only one that fits. Viracocha, who used his transformer encoding technique on the bas-relief of the Gateway of the Sun (appendix 1), must have carried the technique to Mexico c. AD 750, in the guise of Lord Pacal.

The Viracocha tunic pattern will now facilitate decoding of the upper foot girdle engraving; figures 57bi and bii show the Viracocha pattern tilted counterclockwise by 23.5° to facilitate analysis. The first thing we notice is that pattern figure 57bi differs from the pattern in figure 57bii: they are mirror images.

Pattern figure 57bi can now be decoded by following the path through the maze-like pattern and, by using arrows, to show the route covered (figure 57c). The arrows reveal the number 666, the number of the beast from Revelation.

But a closer look at the chalice engraving shows that the pattern is identical to the mirror-image pattern, figure 58aii, which does not yield the number 6. Nor does it reveal the number 9, which is what you might expect the mirror image to produce. Viewing the chalice engraving from above (figure 59a) in fact reveals nothing of any numerical significance at all. At least it reveals nothing until we view the chalice maze-like engraving from beneath the foot-cone.

The Secrets of the Quartz Crystal

When we lift the chalice and view the *virtual* pattern, the numbers 99999... now appear (figure 59b) [if it were possible to see through the metal] which tells us that the engraving is intended to be viewed from below, upwards towards Heaven. But it still comes as a surprise that when the pattern is viewed from above the 666 of the physical world does not appear. So, how can 666 be derived from the maze-like pattern around the foot-cone?

The only way to convert the number 666 into the number 999 using mirror imaging is shown in figure 59c. Firstly take the number 666. Then take the *horizontal* mirror image, as shown by the arrow. Then take the *vertical* mirror image of the result, again shown by an arrow. The same technique can again be used to convert 999 into 666, once again using arrows. What results is a rotating arrow network.

Decoding the Viracocha Pattern (I)

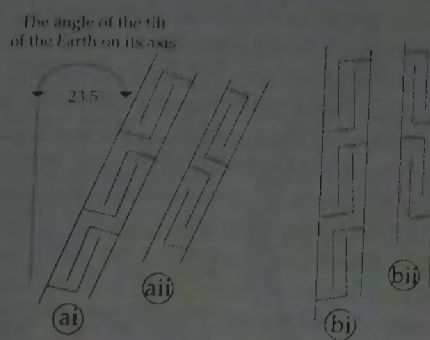
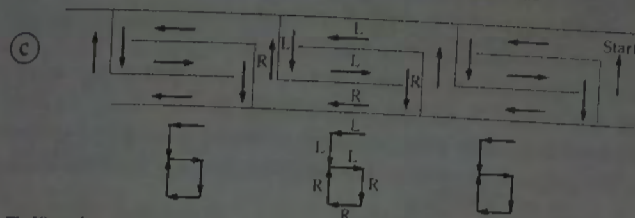

Figure 57. (ai) and (aii) The angle of the maze-like pattern on Viracocha's tunic is 23.5° to the vertical, representing the tilt of the Earth on its axis (see appendix 4, The Viracocha Transformer of Tiahuanaco). (bi) and (bii) The maze-like pattern corrected by 23.5° to facilitate analysis.

Decoding the Viracocha Pattern (II)



The Viracocha pattern (ai) contains secret information. To follow the path through the maze, the initiate must turn left, left, and then left again (L, L, L), then right, right and right (R, R, R) again. When this instruction is followed—and laid out using arrows (as shown)—the numbers 666 are revealed. The same number, associated with a dragon, is given in the Bible when describing a beast that rises from the sea...

... the dragon gave him his power and his seat and great authority... here is wisdom, let him that hath understanding count the number of the beast, for it is the number of a man, and his number is six hundred three score and six [666] Revelation XIII, 1-18

Decoding the Viracocha Pattern (III)

Figure 58. (ai) The Viracocha pattern translates into the numbers 666. However, (aii) shows that the adjacent pattern—the identical pattern to that on the Grail—does not yield the number 6. Nor does it yield the number 9. However, it does reveal the mirror image of the number 6 (associating the pattern with the soul).

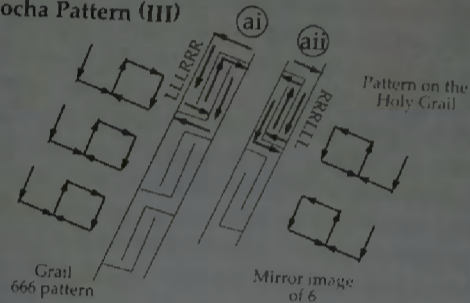

Decoding the Viracocha Pattern (I)

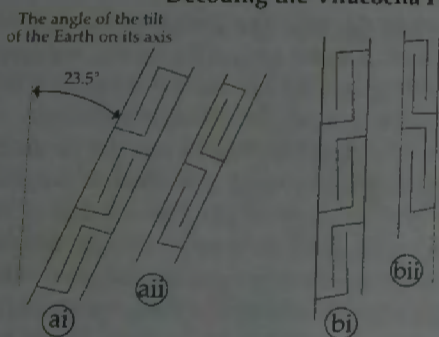
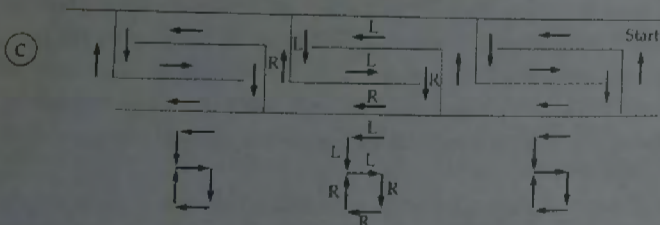

Figure 57. (ai and aii) The angle of the maze-like pattern on Viracocha's tunic is 23.5° to the vertical, representing the tilt of the Earth on its axis (see Appendix I, the Viracocha Transformer of Tiahuanaco). (bi and bii) The maze-like pattern corrected by 23.5° to facilitate analysis.

Decoding the Viracocha Pattern (II)



The Viracocha pattern (ai) contains secret information. To follow the path through the maze the initiate must turn left, left, and then left again (L, L, L), then right, right and right (R, R, R) again. When this instruction is followed—and laid out using arrows (as shown)—the numbers 666 are revealed. The same number, associated with a dragon, is given in the Bible when describing a beast that rises from the sea...

... the dragon gave him his power and his seat and great authority... here is wisdom, let him that hath understanding count the number of the beast, for it is the number of a man, and his number is six hundred three score and six [666] Revelation XIII, 1-18

Decoding the Viracocha Pattern (III)

Figure 58. (ai) The Viracocha pattern translates into the numbers 666. However, (aii) shows that the adjacent pattern—the identical pattern to that on the Grail—does not yield the number 6. Neither does it yield the number 9. However, it does reveal the mirror image of the number 6 (associating the pattern with the soul).

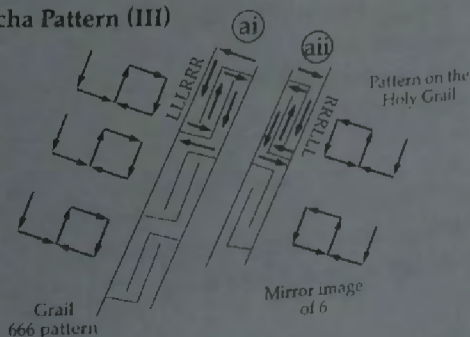

The Secrets of the Quartz Crystal

When we lift the chalice and view the *virtual* pattern the numbers 99999... now appear (figure 59b) [if it were possible to see through the metal] which tells us that the engraving is intended to be viewed from below, upwards towards Heaven. But it still comes as a surprise that when the pattern is viewed from above the 666 of the physical world does not appear. So, how can 666 be derived from the maze-like pattern around the foot-cone?

The only way to convert the number 666 into the number 999 using mirror imaging is shown in figure 59c; firstly take the number 666. Then take the *horizontal* mirror image, as shown by the arrow. Then take the *vertical* mirror image of the result, again shown by an arrow. The same technique can again be used to convert 999 into 666, once again using arrows. What results is a rotating arrow network.

Viewed from below, this attempt [to intellectually convert 666 into 999—an attempt to convert the body into a soul] endows upon the centre crystal *circulating* arrows, which in turn cause the centre quartz crystal to *virtually spin*, emulating the Sun as it spins on its axis. This means that the quartz crystal must represent the Sun, confirming the proposition put forward by the Arthurian legends that the Holy Grail radiates light, as shown in plate 19—it contains within it the Sun. Only Arthur (who is shown in plate 19 worshipping the Holy Grail radiating light) could have known this and only Arthur could have carved the maze-like pattern on the upper-foot-cone to convey this information.

Amazingly, closer inspection of the Hallstatt maze-like pattern (figure 4) shows that it too contains *both* versions of the maze-like pattern, the original and the mirror image [the pattern very cleverly reverses beneath the hands of each of the twins]. Which means that whoever carved the pattern on the Hallstatt scabbard understood the same knowledge as whoever carved *both* patterns on the tunic of Viracocha 1,700 years later. Which in turn means that the Hallstatt Celts acquired their super-knowledge from a Supergod, who must have been the King of Hochdorf (whose number was 999) who died in around 550 BC.

The Secrets of the Swastika Panels

But surely, if the chalice was engraved 450 years after it was made, it

Decoding the Viracocha Pattern (I)

The angle of the tilt of the Earth on its axis

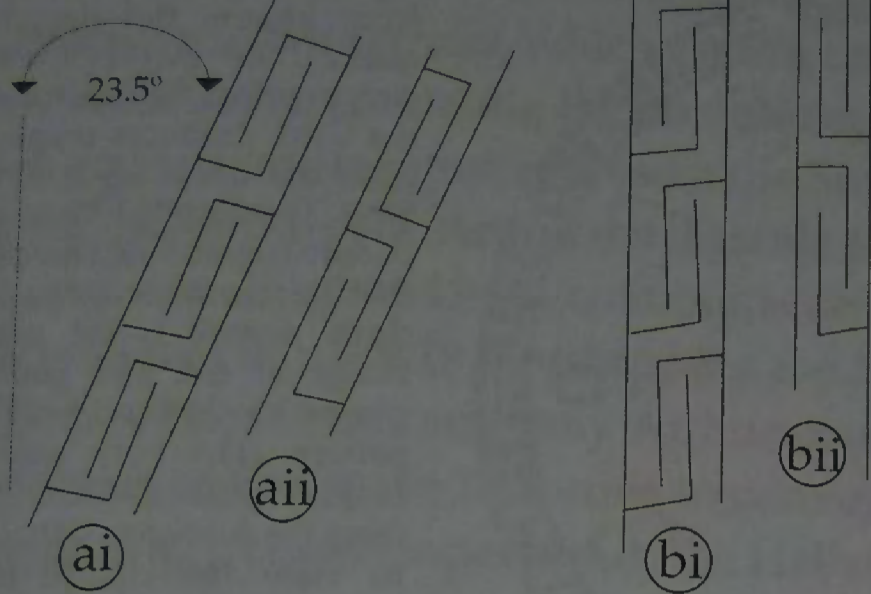
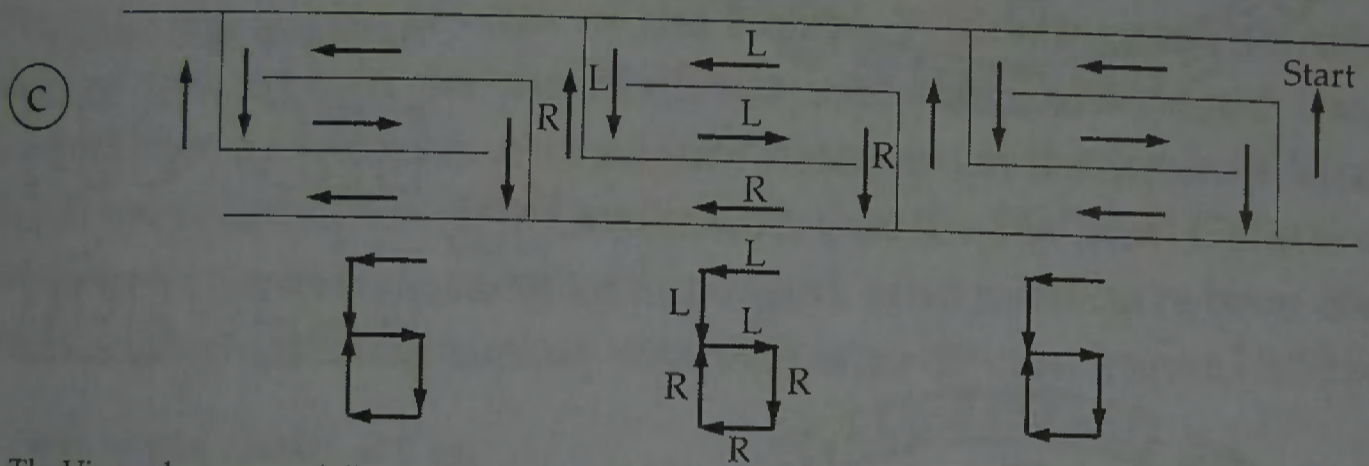

Figure 57. (ai) and (aii) The angle of the maze-like pattern on Viracocha's tunic is 23.5° to the vertical, representing the tilt of the Earth on its axis (see appendix 4, The Viracocha Transformer of Tiahuanaco). (bi) and (bii) The maze-like pattern corrected by 23.5° to facilitate analysis.

Decoding the Viracocha Pattern (II)



The Viracocha pattern (ai) contains secret information. To follow the path through the maze, the initiate must turn left, left, and then left again (L, L, L), then right, right and right (R, R, R) again. When this instruction is followed—and laid out using arrows (as shown)—the numbers 666 are revealed. The same number, associated with a dragon, is given in the Bible when describing a beast that rises from the sea . . .

. . . the dragon gave him his power and his seat and great authority . . . here is wisdom, let him that hath understanding count the number of the beast, for it is the number of a man, and his number is six hundred three score and six [666]. Revelation XIII, 1-18

Decoding the Viracocha Pattern (III)

Figure 58. (ai) The Viracocha pattern translates into the numbers 666. However, (aii) shows that the adjacent pattern—the identical pattern to that on the Grail—does not yield the number 6. Nor does it yield the number 9. However, it does reveal the mirror image of the number 6 (associating the pattern with the soul).

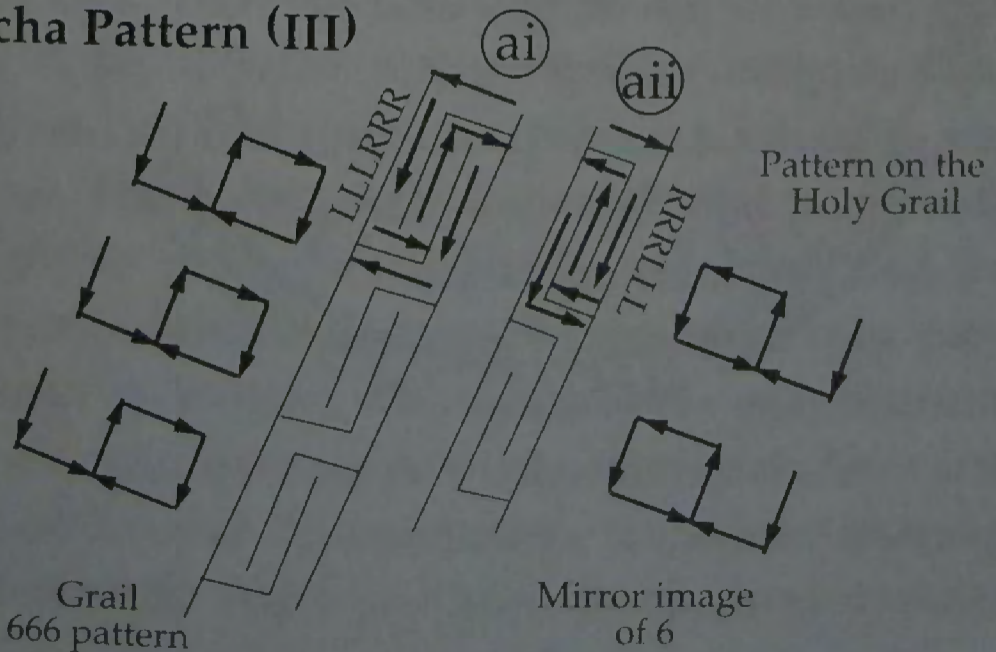

Decoding the Viracocha Pattern (I)

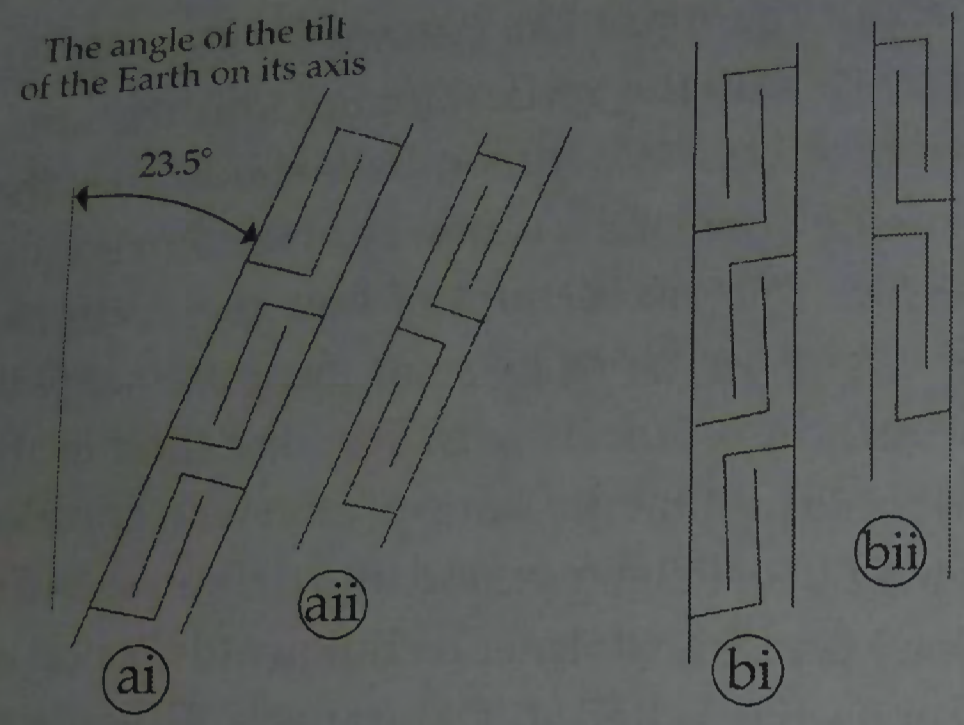
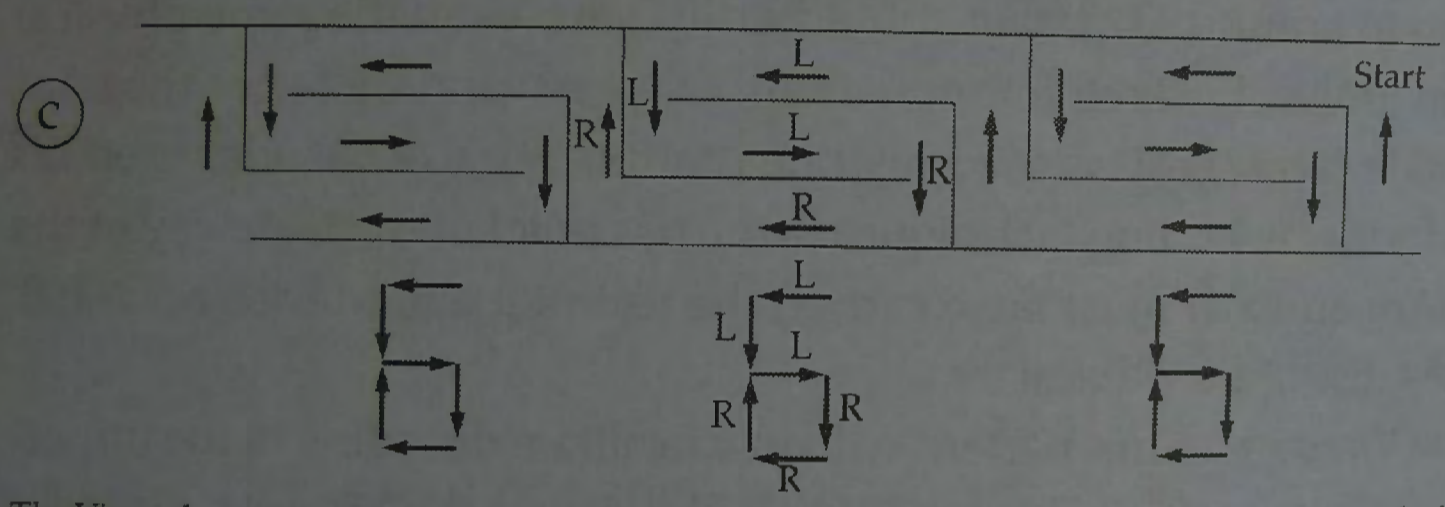

Figure 57. (ai and aii) The angle of the maze-like pattern on Viracocha's tunic is 23.5° to the vertical, representing the tilt of the Earth on its axis (see Appendix 1, the Viracocha Transformer of Tiahuanaco). (bi and bii) The maze-like pattern corrected by 23.5° to facilitate analysis.

Decoding the Viracocha Pattern (II)



The Viracocha pattern (ai) contains secret information. To follow the path through the maze the initiate must turn left, left, and then left again (L, L, L), then right, right and right (R, R, R) again. When this instruction is followed—and laid out using arrows (as shown)—the numbers 666 are revealed. The same number, associated with a dragon, is given in the Bible when describing a beast that rises from the sea...

...the dragon gave him his power and his seat and great authority... here is wisdom, let him that hath understanding count the number of the beast, for it is the number of a man, and his number is sixhundred three score and six [666] Revelation XIII, 1-18.

Decoding the Viracocha Pattern (III)

Figure 58. (ai) The Viracocha pattern translates into the numbers 666. However, (aii) shows that the adjacent pattern—the identical pattern to that on the Grail—does not yield the number 6. Neither does it yield the number 9. However, it does reveal the mirror image of the number 6 (associating the pattern with the soul).

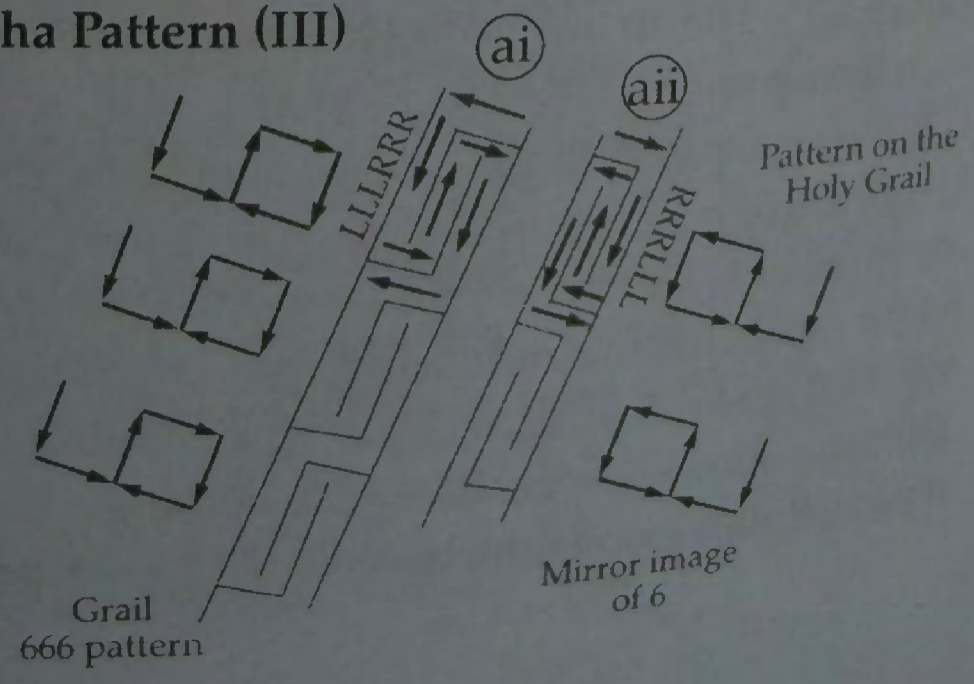

The Secret of the Crystal in the Foot-Cone

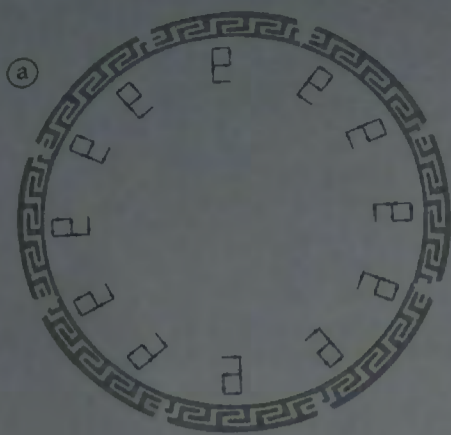
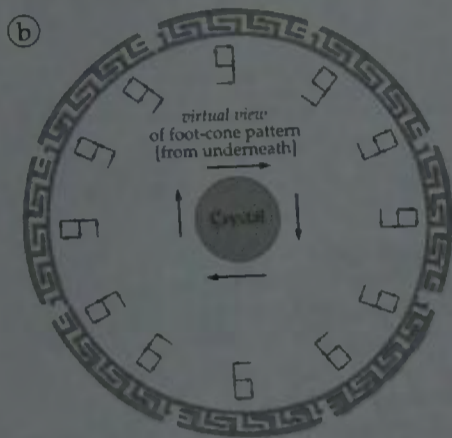
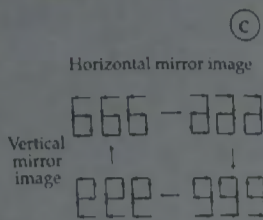

Figure 59. (a) Looking down from above, the decoded maze-like pattern that circumscribes the foot-cone of the Grail produces unintelligible characters, as in figure 58a.ii. The decoded Viracocha pattern (figure 58a.ii) revealed that the true foot-cone pattern (from above) is the mirror image of 666 and yet 999 cannot be obtained from the pattern. The only way to obtain intelligible numbers from the foot-cone pattern is to view the chalice from below.



(b) The virtual pattern now reads 99999... etc. (if the pattern could be seen through the metal of the foot-cone). The analysis reveals that the only real way to obtain the number 999 from 666 is to take the horizontal mirror image of the number 666. (c) Then take the vertical mirror image of the result. The 999 can be changed back into 666 by again taking the horizontal mirror image and again the vertical mirror image of the result. This sets in place a rotating algorithm, shown by arrows in (b). Thus, when the foot-cone is viewed from below, the Grail pattern is transformed into 999 and the centre quartz crystal, the Sun, begins to spin on its axis in accordance with the arrows. In this way the foot-cone contains the super-science of the spinning Sun and the higher orders of spirituality.

Viewed from below, this attempt [to intellectually convert 666 into 999—an attempt to convert the body into a soul] endows upon the centre crystal circulating arrows, which in turn cause the centre quartz crystal to virtually spin, emulating the Sun as it spins on its axis. This means that the quartz crystal must represent the Sun, confirming the proposition put forward by the Arthurian legends that the Holy Grail radiates light, as shown in plate 19—it contains within it the Sun. Only Arthur (who is shown in plate 19 worshipping the Holy Grail radiating light) could have known this and only Arthur could have carved the maze-like pattern on the upper foot-cone to convey this information.

Amazingly, closer inspection of the Hallstatt maze-like pattern (figure 4) shows that it too contains both versions of the maze-like pattern, the original and the mirror image [the pattern very cleverly reverses beneath the hands of each of the twins]. Which means that whoever carved the pattern on the Hallstatt scabbard understood the same knowledge as whoever carved both patterns on the tunic of Viracocha 1,100 years later. Which in turn means that the Hallstatt Celts acquired their super-knowledge from a Supergod, who must have been the King of Hochdorf (whose number was 999) who died in around 550 bc.

The Secrets of the Swastika Panels

But surely, if the chalice was engraved 450 years after it was made, it could never have carried the implied instruction for the centre crystal to virtually spin, to emulate the spinning Sun (and radiate light) at the time it was manufactured.

Figure 60 shows that the lower foot-cone panels are variously patterned; (a) and (c)—two identical pairs—carry a Celtic continuous-line knot-work pattern whereas (bi) and (bii) are covered in swastika and reverse-swastika patterns. The patterns on the mesh-mat panels (d), examined in figure 48, differ, calling for closer examination and the consequential release of encoded information. In the same way, panels (bi) and (bii) differ from each other, calling for closer examination. Generally speaking, the swastika symbol is constructed of six lines and therefore the number 6 will be used to demonstrate the mirror-imaging principles that follow (although any other non-symmetrical number could be used).

The Secret of the Crystal in the Foot-Cone

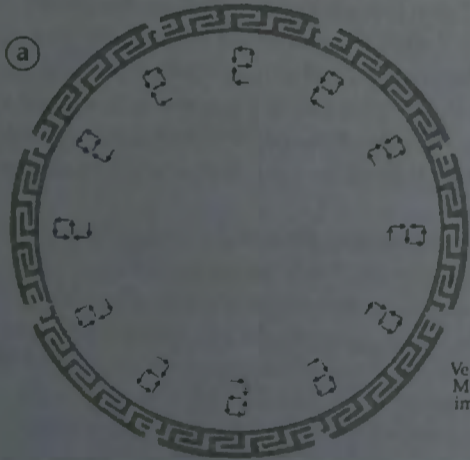
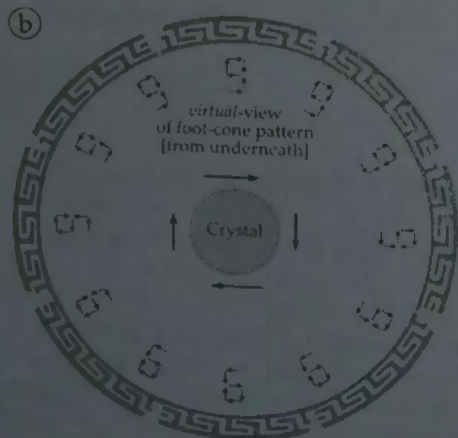
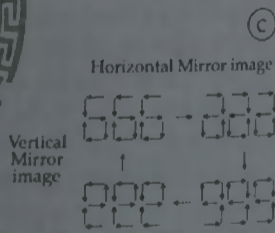

Figure 59. (a) Looking down from above, the decoded maze-like pattern that circumscribes the foot-cone of the Grail produces unintelligible characters, as in figure 58a.ii.



The decoded Viracocha pattern (figure 58a.ii) revealed that the true foot-cone pattern (from above) is the mirror image of 666 and yet 999 cannot be obtained from the pattern. The only way to obtain intelligible numbers from the foot-cone pattern is to view the chalice from below. (b) The virtual pattern now reads 99999... etc. (if the pattern could be seen through the metal of the foot-cone). The analysis reveals that the only real way to obtain the number 999 from 666 is to take the horizontal mirror image of the number 666 (c). Then take the vertical mirror image of the result. The 999 can be changed back into 666 by again taking the horizontal mirror image and again the vertical mirror image of the result. This sets in place a rotating algorithm, shown by arrows in (b). Thus, when the foot-cone is viewed from below the Grail pattern is transformed into 999 and the centre quartz crystal, the Sun, begins to spin on its axis in accordance with the arrows. In this way the foot-cone contains the super-science of the spinning Sun and the higher orders of spirituality.

could never have carried the implied instruction for the centre crystal to virtually spin, to emulate the spinning Sun (and radiate light) at the time it was manufactured?

Figure 60 shows that the lower foot-cone panels are variously patterned; (a) and (c)—two identical pairs—carry a Celtic continuous-line knot-work pattern whereas (bi) and (bii) are covered in swastika and reverse-swastika patterns. The patterns on the mesh-mat panels (d), examined in figure 48, differed, calling for closer examination and the consequential release of encoded information. In the same way, panels bi and bii differ from each other, calling for closer examination. Generally speaking, the swastika symbol is constructed of 6 lines and therefore the number 6 will be used to demonstrate the mirror imaging principles that follow (although any other non-symmetrical number could be used).

The swastikas featured in (bi) are each identical to its neighbour. However, in the panel labelled (bii) adjacent squares carry mirror imaged swastikas, both vertically and horizontally. Closer examination of the (bii) arrangement reveals the same rotating algorithm obtained in figure 59c. This means that the chalice contained the encoded information to enable the quartz crystal to virtually spin (and radiate light) even before it was carved with the maze-like pattern on the upper foot-cone. That, in turn, means that King Arthur (or Merlin) likewise decoded the swastika panels and then engraved the same algorithm in a different way—using the maze-like pattern—to obtain the same result. Moreover, the original swastika pattern specifically refers to the revolving Sun on its axis whereas the maze-like pattern, of the Hallstatt scabbard and Viracocha is, initially, much more obscure and easier to overlook. The (bii) pattern also results in a series of crosses ((bii), in-filled with grey).

The Secrets of the Yellow Rim and the Nails

Adding a ring of brass to the lip (figures 61a and 61c) has softened the rim of the bowl. A groove is moulded into the brass ring to provide an imperfect (sloppy) fit with the metal rim of the bowl. The ring is then held in position by three tapered brass nails equally spaced (figure 61b) around the rim and the bowl which are then bent inwards towards the bowl. The distribution of the nails (figure 61b) accords with the geometric angles of an equilateral triangle (666) the number of the body. When the

The Secret of the Crystal in the Foot-Cone

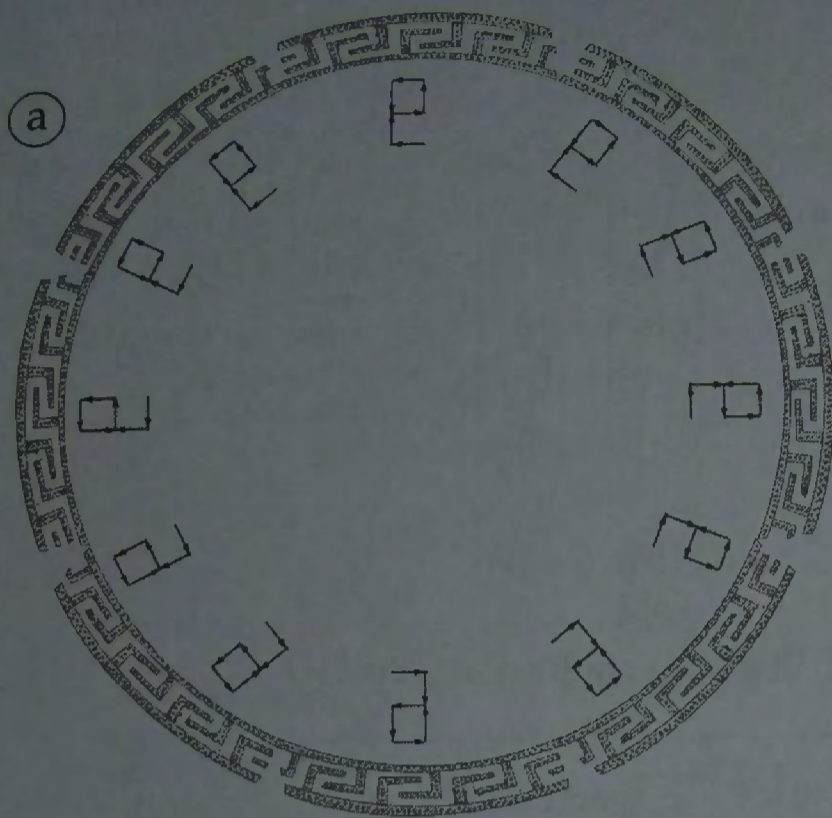
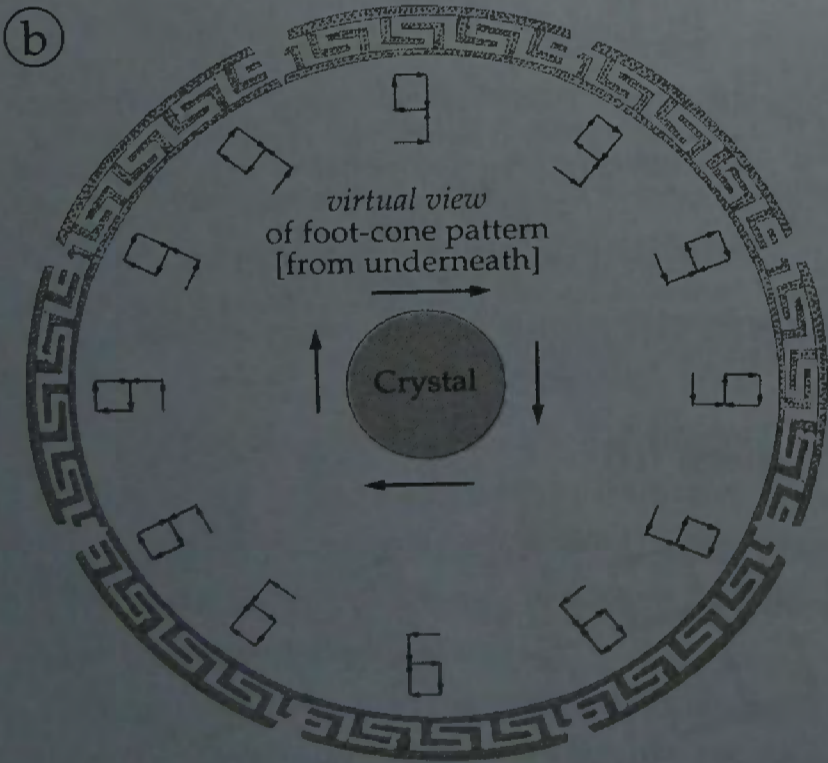
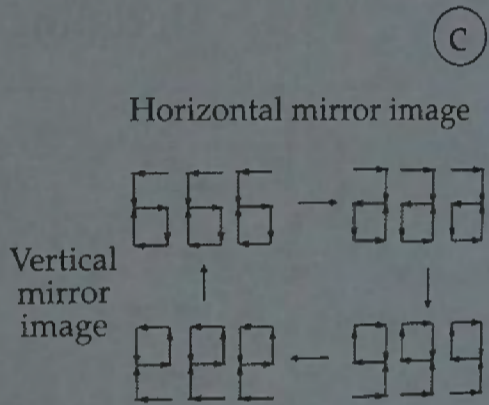

Figure 59. (a) Looking down from above, the decoded maze-like pattern that circumscribes the foot-cone of the Grail produces unintelligible characters, as in figure 58aii. The decoded Viracocha pattern (figure 58aii) revealed that the true foot-cone pattern (from above) is the mirror image of 666 and yet 999 cannot be obtained from the pattern. The only way to obtain intelligible numbers from the foot-cone pattern is to view the chalice from below.



(b) The virtual pattern now reads 99999 . . . etc. (if the pattern could be seen through the metal of the foot-cone). The analysis reveals that the only real way to obtain the number 999 from 666 is to take the horizontal mirror image of the number 666. (c) Then take the vertical mirror image of the result. The 999 can be changed back into 666 by again taking the horizontal mirror image and again the vertical mirror image of the result. This sets in place a rotating algorithm, shown by arrows in (b). Thus, when the foot-cone is viewed from below, the Grail pattern is transformed into 999 and the centre quartz crystal, the Sun, begins to spin on its axis in accordance with the arrows. In this way the foot-cone contains the super-science of the spinning Sun and the higher orders of spirituality.



The Secrets in the Swastika Panels

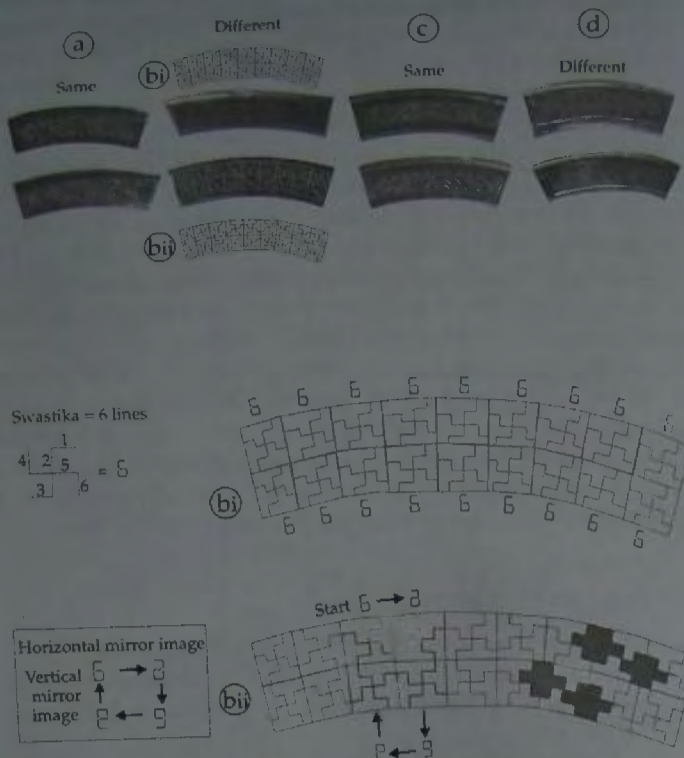

Figure 60. The lower foot-cone panels are variously patterned: (a) and (c)—two identical pairs—carry a Celtic continuous-line knot-work pattern; (b) and (bii) are covered in swastika and reverse-swastika patterns. The patterns on the mesh-mat panels (d) differ, calling for closer examination and the consequential release of encoded information (previously analysed in figure 48). In the same way, panels bi and bii differ, calling for closer examination. The swastika is made up of six lines. (bi) shows each swastika to be identical to its neighbour. However, (bii) shows that adjacent squares carry mirror-imaged swastikas, both vertically and horizontally. Closer examination of (bii) reveals the same rotating algorithm obtained in figure 59c. This means that the chalice contained the encoded information to enable the quartz crystal to *virtually spin* (and radiate light) even before it was carved with the maze-like pattern on the upper foot-cone, which, in turn, means that King Arthur (or Merlin) likewise decoded the swastika panels and then engraved the same algorithm in a different way—using the maze-like pattern—to obtain the same result. Moreover, the original *swastika* pattern specifically refers to the revolving Sun on its axis, whereas the maze-like pattern of the Hallstatt scabbard and Viracocha is, initially, much more obscure and easier to overlook. The (bii) pattern results in a series of crosses [(bii), in-filled with grey].

The swastikas featured in (bi) are each identical to its neighbour. However, in the panel labelled (bii), adjacent squares carry mirror-imaged swastikas, both vertically and horizontally. Closer examination of the (bii) arrangement reveals the same rotating algorithm obtained in figure 59c. This means that the chalice contained the encoded information to enable the quartz crystal to *virtually spin* (and radiate light) even before it was carved with the maze-like pattern on the upper foot-cone. That, in turn, means that King Arthur (or Merlin) likewise decoded the swastika panels and then engraved the same algorithm in a different way—using the maze-like pattern—to obtain the same result. Moreover, the original swastika pattern specifically refers to the revolving Sun on its axis, whereas the maze-like pattern of the Hallstatt scabbard and Viracocha is, initially, much more obscure and easier to overlook. The (bii) pattern also results in a series of crosses [(bii), in-filled with grey].

The Secrets of the Yellow Rim and the Nails

Adding a ring of brass to the lip (figures 61a and 61c) has softened the rim of the bowl. A groove is moulded into the brass ring to provide an imperfect (sloppy) fit with the metal rim of the bowl. The ring is then held in position by three tapered brass nails equally spaced (figure 61b) around the rim and the bowl, which are then bent inwards towards the bowl. The distribution of the nails (figure 61b) accords with the geometric angles of an equilateral triangle (666), the number of the body. When the three nails are removed, the ring can be removed from the rim (figure 61c). The ratio of the length of the dimensions of the curiously 'not-quite-square' chalice now change, reducing from 178 mm x 185 mm to 176.7 mm x 179.7 mm [the width decreases by more than twice the change in the height]. Thus by removing the three nails the chalice becomes more 'square', enabling the release of more virtue and knowledge. The reason for removing the nails and the golden rim was discussed earlier, in chapter 2, and is provided here again for easy reference:

Esotericists, like the Shamans, possess supernatural powers allowing them to function in one of two worlds at will, the physical or the spiritual. Thus, through instruction received from the

The Secrets in the Swastika Panels

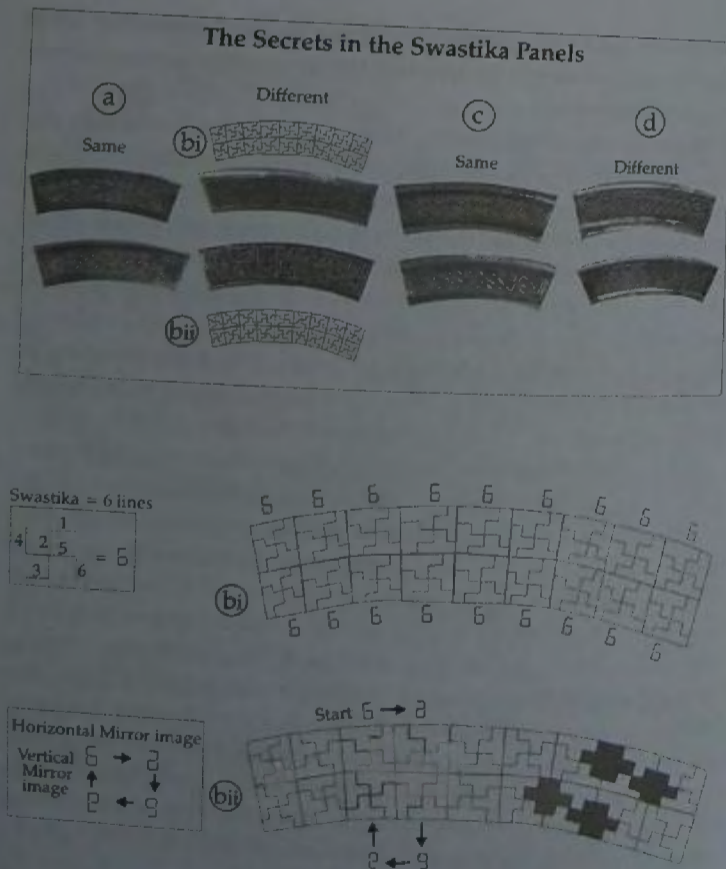

Figure 60. The lower foot-cone panels are variously patterned; (a) and (c)—two identical pairs—carry a Celtic continuous-line knot-work pattern; (b) and (bii) are covered in swastika and reverse-swastika patterns. The patterns on the mesh-mat panels (d) differ, calling for closer examination and the consequential release of encoded information (previously analysed in figure 48). In the same way, panels (bi) and (bii) differ, calling for closer examination. The swastika is made-up of 6 lines. (bi) shows each swastika to be identical to its neighbour. However, (bii) shows that adjacent squares carry mirror imaged swastikas, both vertically and horizontally. Closer examination of (bii) reveals the same rotating algorithm obtained in figure 59c. This means that the chalice contained the encoded information to enable the quartz crystal to *virtually spin* (and radiate light) even before it was carved with the maze-like pattern on the upper foot-cone which, in turn, means that King Arthur (or Merlin) likewise decoded the swastika panels and then engraved the same algorithm in a different way—using the maze-like pattern—to obtain the same result. Moreover, the original *swastika* pattern specifically refers to the revolving Sun on its axis whereas the maze-like pattern of the Hallstatt scabbard and Viracocha is, initially, much more obscure and easier to overlook. The (bii) pattern results in a series of crosses [(bii), in-filled with grey].

three nails are removed the ring can be removed from the rim (figure 61c). The ratio of the length of the dimensions of the curiously 'not-quite-square' chalice now change, reducing from 178mm by 185mm to 176.7mm by 179.7mm [the width decreases by more than twice the change in the height]. Thus by removing the three nails the chalice becomes more 'square', enabling the release of more virtue and knowledge. The reason for removing the nails and the golden rim was discussed earlier, in Chapter 2, and is provided here again, for easy reference:

Esotericists, like the Shamans, possess supernatural powers allowing them to function in one of two worlds at will, the physical or the spiritual. Thus, through instruction received from the Brotherhood, the soul can leave the body at will to experience what is today called an 'out-of-body-experience'. It is believed that their temple exists in the spiritual dimension above and away from the profane. It is as though the intellectual body hitches itself to the spiritual and in so doing experiences consciousness free of physical or emotional restraint. This capability is not open to lower initiates but only to the higher adepts who have progressed through disciplined study of the sacred sciences, years of devotion and probation.

Temporary evacuation of the soul from the body results from a three-fold technique obtainable only by disciplined meditation and ritual, which teaches men how to function away from the physical body at will. They teach that the spiritual nature, the soul, is attached to the physical form at certain points, symbolised by the [three] nails of the Crucifixion. Through initiation they are taught to *withdraw the nails*, enable the divine nature of man to come down from the cross and *thereby release their own soul* from their body into another dimension. Out-of-body-experiences are possible only once the emotional, intellectual and physical bodies are at peace and equilibrium which in turn is achieved through the meditation and ritual.

During an out-of-body-experience the soul leaves the body through a mythical silver thread that, with practice, extends from the navel. The journeying soul can leave the body safely, providing the higher intellect holds this umbilical cord tight to provide a return path to the body. The

The Secrets in the Swastika Panels

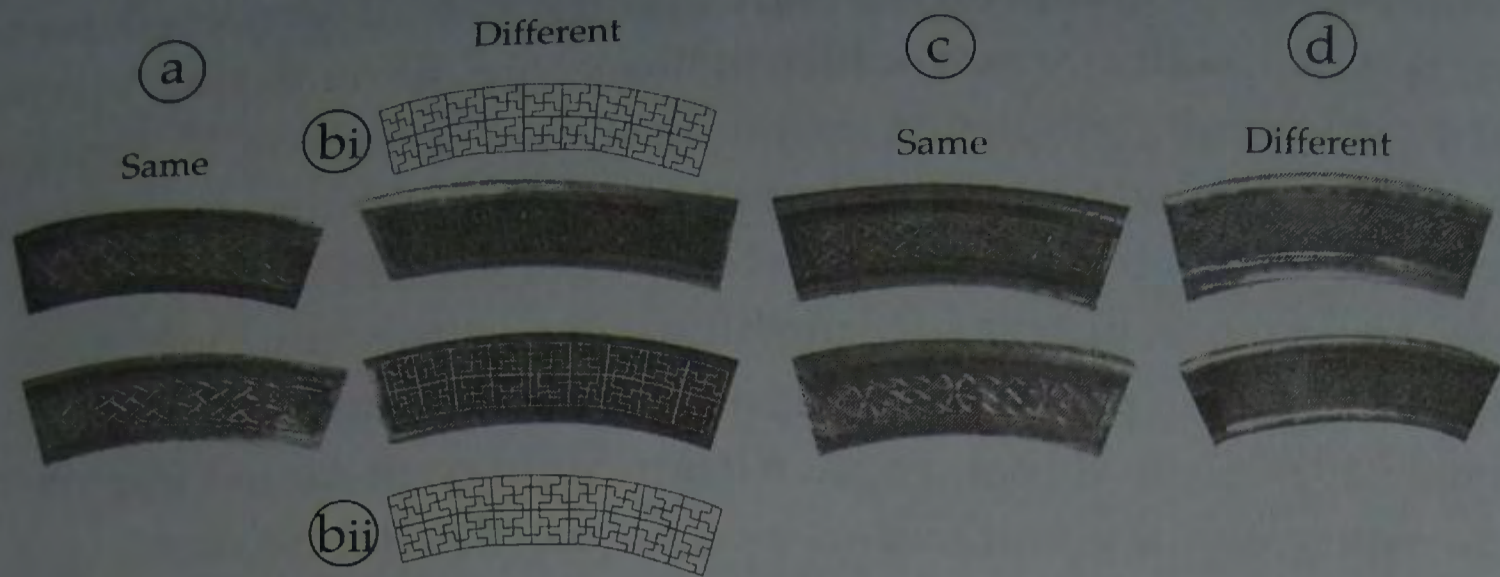

Swastika = 6 lines

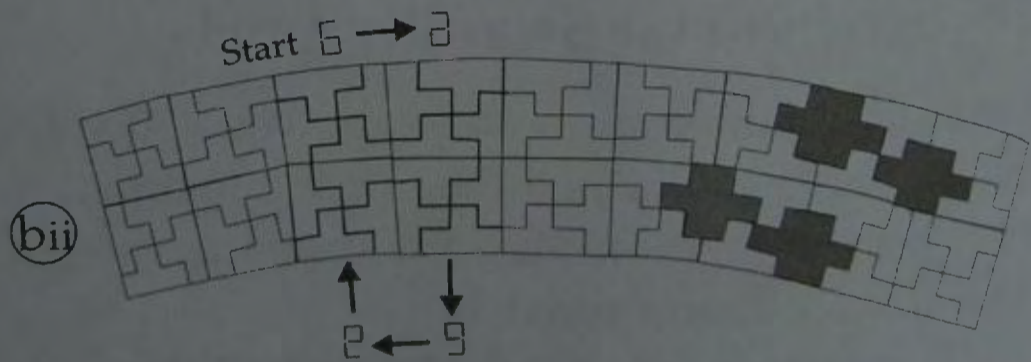
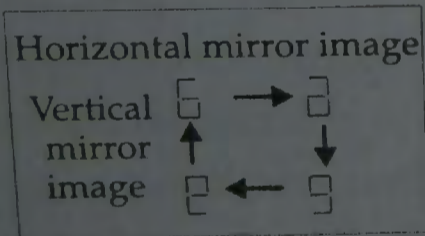
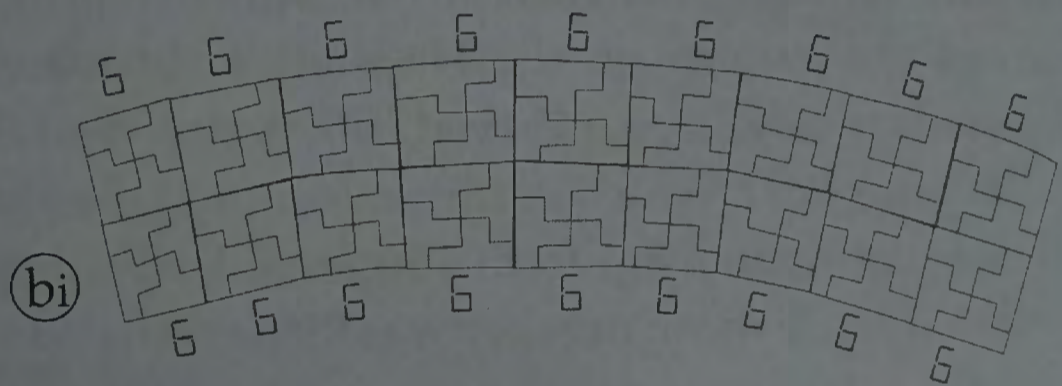
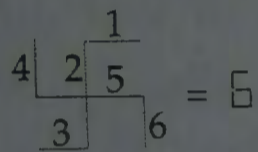
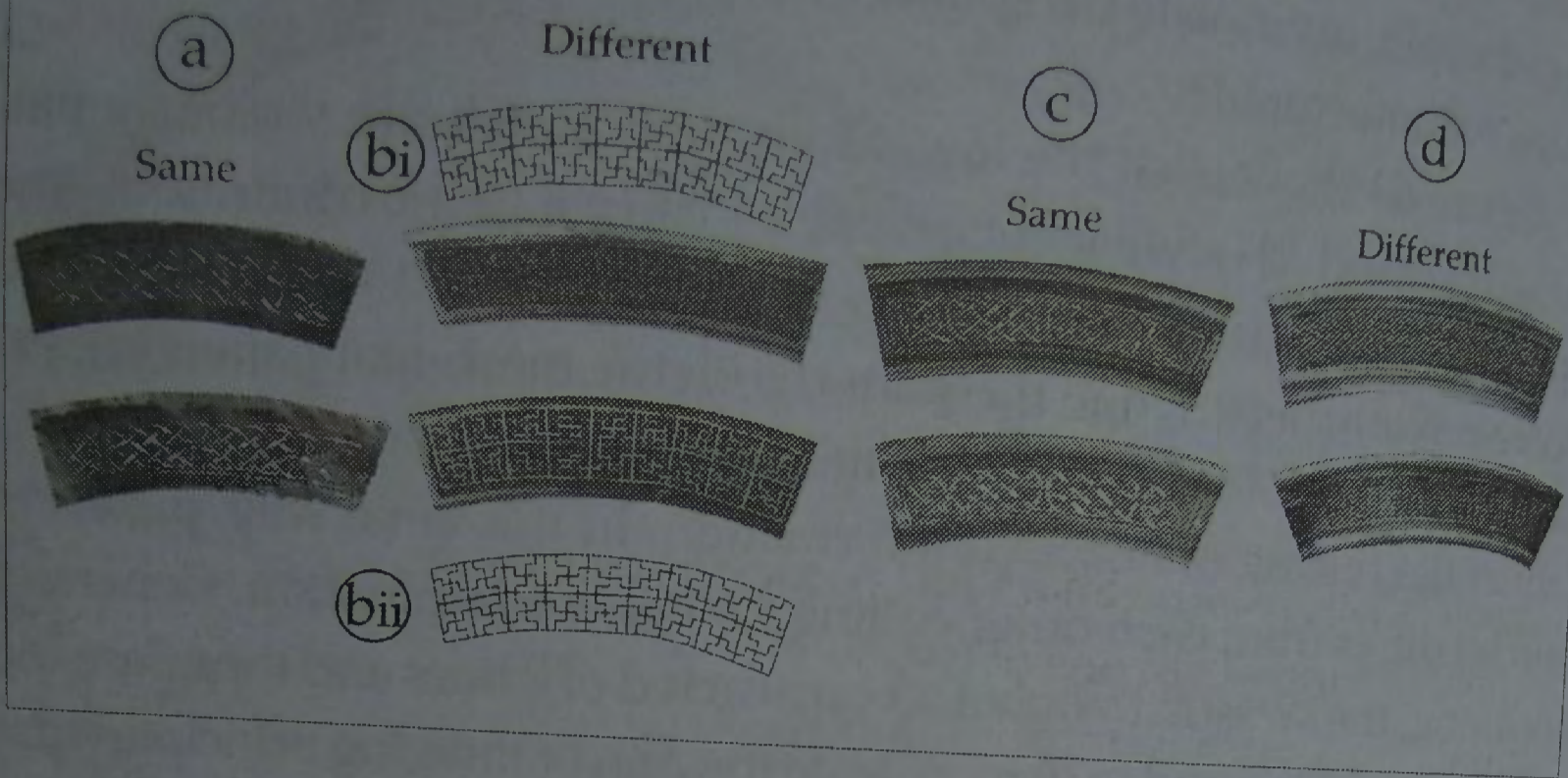

Figure 60. The lower foot-cone panels are variously patterned: (a) and (c)—two identical pairs—carry a Celtic continuous-line knot-work pattern; (bi) and (bii) are covered in swastika and reverse-swastika patterns. The patterns on the mesh-mat panels (d) differ, calling for closer examination and the consequential release of encoded information (previously analysed in figure 48). In the same way, panels bi and bii differ, calling for closer examination. The swastika is made up of six lines. (bi) shows each swastika to be identical to its neighbour. However, (bii) shows that adjacent squares carry mirror-imaged swastikas, both vertically and horizontally. Closer examination of (bii) reveals the same rotating algorithm obtained in figure 59c. This means that the chalice contained the encoded information to enable the quartz crystal to *virtually* spin (and radiate light) even before it was carved with the maze-like pattern on the upper foot-cone, which, in turn, means that King Arthur (or Merlin) likewise decoded the swastika panels and then engraved the same algorithm in a different way—using the maze-like pattern—specifically refers to the revolving Sun on its axis, whereas the maze-like pattern of the Hallstatt scabbard and Viracocha is, initially, much more obscure and easier to overlook. The (bii) pattern results in a series of crosses [(bii), in-filled with grey].

The Secrets in the Swastika Panels



Swastika = 6 lines

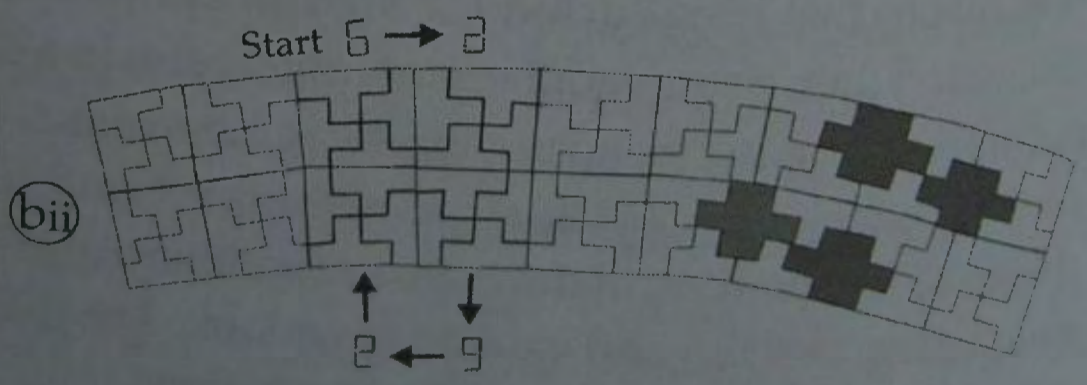
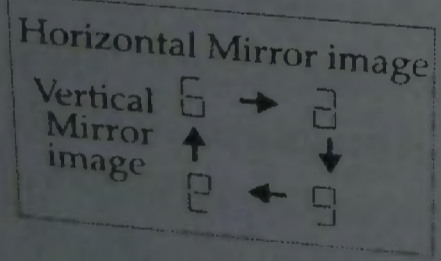
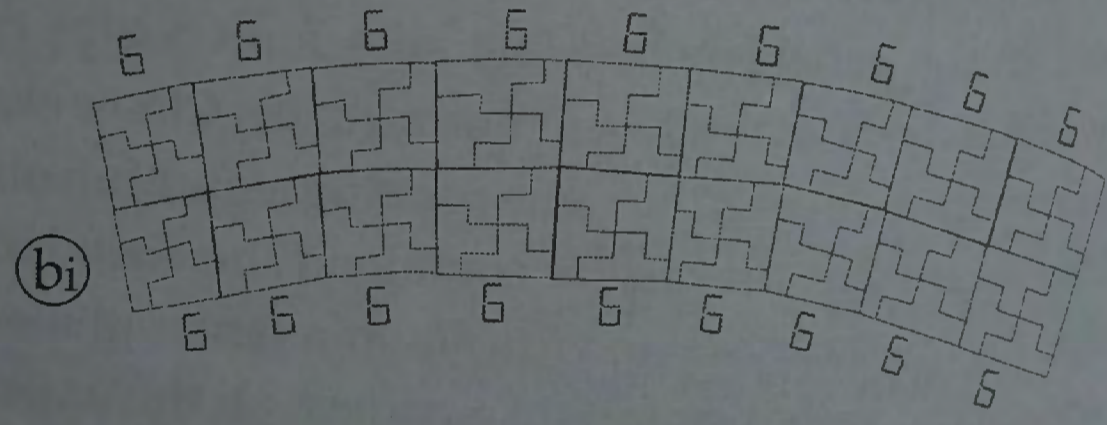
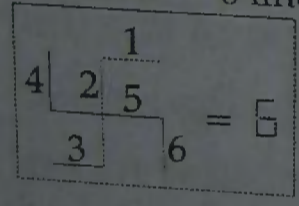

Figure 60. The lower foot-cone panels are variously patterned; (a) and (c)—two identical pairs—carry a Celtic continuous-line knot-work pattern; (bi) and (bii) are covered in swastika and reverse-swastika patterns. The patterns on the mesh-mat panels (d) differ, calling for closer examination and the consequential release of encoded information (previously analysed in figure 48). In the same way, panels (bi) and (bii) differ, calling for closer examination. The swastika is made-up of 6 lines. (bi) shows each swastika to be identical to its neighbour. However, (bii) shows that adjacent squares carry mirror imaged swastikas, both vertically and horizontally. Closer examination of (bii) reveals the same rotating algorithm obtained in figure 59c. This means that the chalice contained the encoded information to enable the quartz crystal to *virtually* spin (and radiate light) even before it was carved with the maze-like pattern on the upper foot-cone which, in turn, means that King Arthur (or Merlin) likewise decoded the swastika panels and then engraved the same algorithm in a different way—using the maze-like pattern—to obtain the same result. Moreover, the original *swastika* pattern specifically refers to the revolving Sun on its axis whereas the maze-like pattern, of the Hallstatt scabbard and the Viracocha is, initially, much more obscure and easier to overlook. The (bii) pattern results in a series of crosses ((bii), in-filled with grey).

Brotherhood, the soul can leave the body at will to experience what is today called an 'out-of-body experience'. It is believed that their temple exists in the spiritual dimension above and away from the profane. It is as though the intellectual body hitches itself to the spiritual and in so doing experiences consciousness free of physical or emotional restraint. This capability is not open to lower initiates but only to the higher adepts who have progressed through disciplined study of the sacred sciences, years of devotion and probation.

Temporary evacuation of the soul from the body results from a three-fold technique obtainable only by disciplined meditation and ritual, which teaches men how to function away from the physical body at will. They teach that the spiritual nature, the soul, is attached to the physical form at certain points, symbolised by the [three] nails of the Crucifixion. Through initiation they are taught to *withdraw the nails*, enable the divine nature of man to come down from the cross and thereby release their own soul from their body into another dimension. Out-of-body experiences are possible only once the emotional, intellectual and physical bodies are at peace and equilibrium which in turn is achieved through meditation and ritual.

During an out-of-body experience the soul leaves the body through a mythical silver thread that, with practice, extends from the navel. The journeying soul can leave the body safely, providing the higher intellect holds this umbilical cord tight to provide a return path to the body. The practice is dangerous, as breakage of the silver thread precludes its return to the body. Should this happen, then the initiate would die. Ecclesiastes, in the Bible, says this:

... Man goeth to his long home and the mourners go about the streets; or ever the silver cord be loosed or the golden bowl (halo) be broken... then shall the dust return to the Earth as it was; and the spirit shall return to God who gave it. (Ecclesiastes XII, 5-7)

Moreover, the squared-off version of the chalice (the square) now represents the Earth and the circular bowl the Sun *inside* the Earth, or the Sun *on* Earth (the Son of God on Earth), commemorating the visit of Jesus.

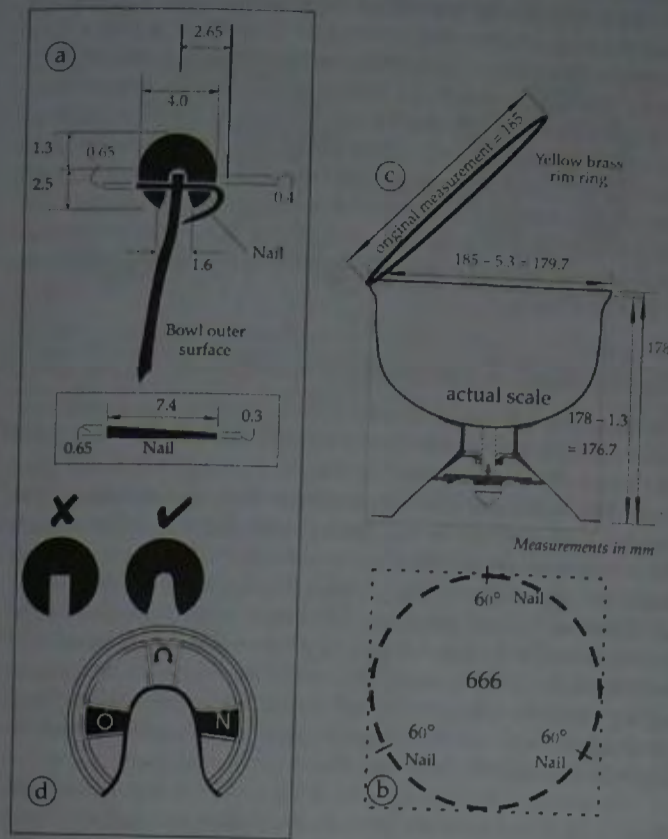

Figure 61. (a) The rim of the chalice has been softened by adding a ring of brass to the lip. A groove is moulded into the brass to provide an imperfect fit with the bowl. The rim is held in place by three tapered brass nails equally spaced (b) around the rim and the bowl and then bent towards the bowl. The distribution accords with the geometric angles of an equilateral triangle (666), the number of the body. When the three nails are removed, the ring can be removed from the rim (c). The ratio of the length of the dimensions of the curiously 'not-quite-square' piece now change, reducing from 178 mm x 185 mm to 176.7 mm x 179.7 mm [the width decreases by more than twice the change in the height]. Thus by removing the three nails the chalice becomes more 'square'. This describes the esoteric practise of removing the nails of the Crucifixion, enabling the divine nature of man (the soul, or halo—the brass rim ring) to be released from the body (666) (see main text). (d) The reason for the unusual profile of the groove in the ring and the reason for the wedge-shaped nails now become clear.

The Secrets of the Yellow Rim

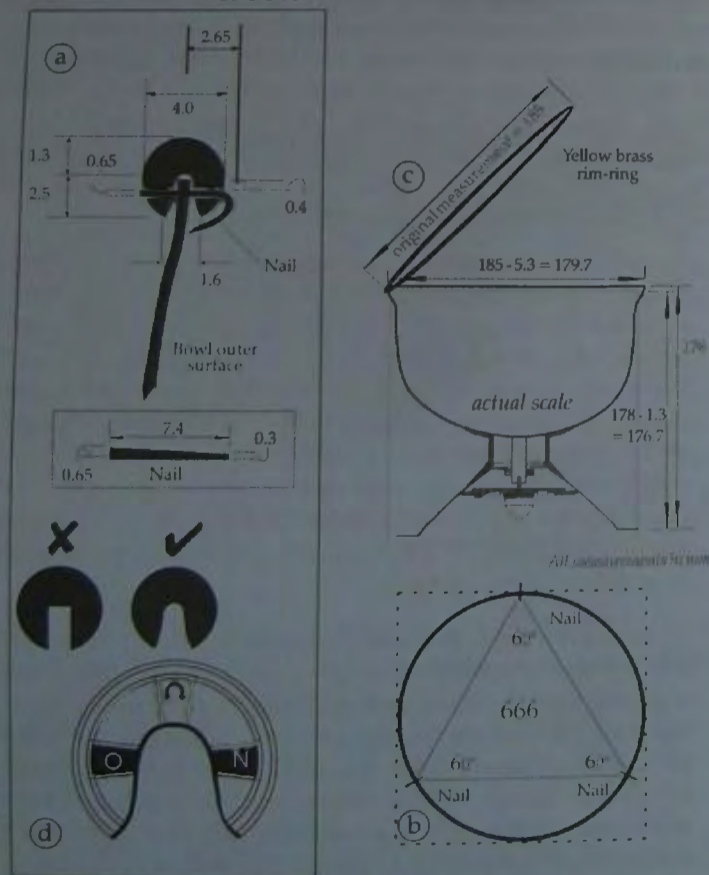

Figure 61. (a) The rim of the chalice has been softened by adding a ring of brass to the lip. A groove is moulded into the brass to provide an imperfect fit with the bowl. The ring is held in place by three tapered brass nails equally spaced (b) around the rim and the bowl and then bent towards the bowl. The distribution accords with the geometric angles of an equilateral triangle (666) the number of the body. When the three nails are removed, the ring can be removed from the rim (c). The ratio of the length of the dimensions of the curiously 'not-quite-square' piece now change, reducing from 178 mm by 185 mm to 176.7 mm by 179.7 mm [the width decreases by more than twice the change in the height]. Thus by removing the three nails the chalice becomes more 'square'. This describes the esoteric practise of removing the nails of the Crucifixion, enabling the divine nature of man (the soul, or halo—the brass rim-ring) to be released from the body (666), (see main text). (d) The reason for the unusual profile of the groove in the ring and the reason for the wedge-shaped nails now becomes clear.

practice is dangerous, as breakage of the silver thread precludes its return to the body. Should this happen then the initiate would die. Ecclesiastes, in the Bible, says this:

...Man goeth to his long home and the mourners go about the streets; or ever the silver cord be loosed or the golden bowl (halo) be broken... then shall the dust return to the Earth as it was; and the spirit shall return to God who gave it. (Ecclesiastes XII, 5-7). [Author's italics and brackets].

Moreover, the squared-off version of the chalice (the square) now represents the Earth and the circular bowl the Sun *inside* the Earth, or the Sun *on* Earth (the Son of God on Earth), commemorating the visit of Jesus.

The reason for the unusual profile of the [sloppy] groove in the brass rim-ring now becomes clear (figure 61d); the gold-plated brass ring represents a ring of light, a halo, and the unusual profile-cut deliberately contains the shape of a human head—the two together referring to a halo around the profile of a human head. Each of the three tapered nails, in this scheme, is thus driven through the head of Christ (through Christ) confirming that the 3 rim-nails (spaced at 60° intervals) represent the nails driven into Christ on the cross, on Earth (666). At the same time the nails through the head draw attention to the wounds to the head caused by the crown of thorns that Christ wore at the Crucifixion.

The Secrets of the Handle Escutcheon Plates

Each handle (plate 23) is made of cast silver, heavily decorated with inlaid enamelled panels fixed to the bowl by two rivets at the top, and two below, that are concealed by four tiny semispherical blue glass studs. The escutcheon plates are fixed to the bowl beneath each of the handles. Each plate carries four fillgree panels and three large subconical enamel studs (figure 62). The complex shape of these studs raises suspicion because the bowl girdle studs (figure 51) are finished with a gently convex sectioned-arch shape. If a bowl girdle stud were fired at a body it may well cause bruising. If a subconical bullet-shaped stud were fired at a body it would penetrate. The subconical stud immediately becomes *aggressive*. Together, the arrangement of the three escutcheon studs takes the shape of an upside-down equilateral triangle (999) which must represent the soul, or Godly, energy.

The Secrets of the Yellow Rim

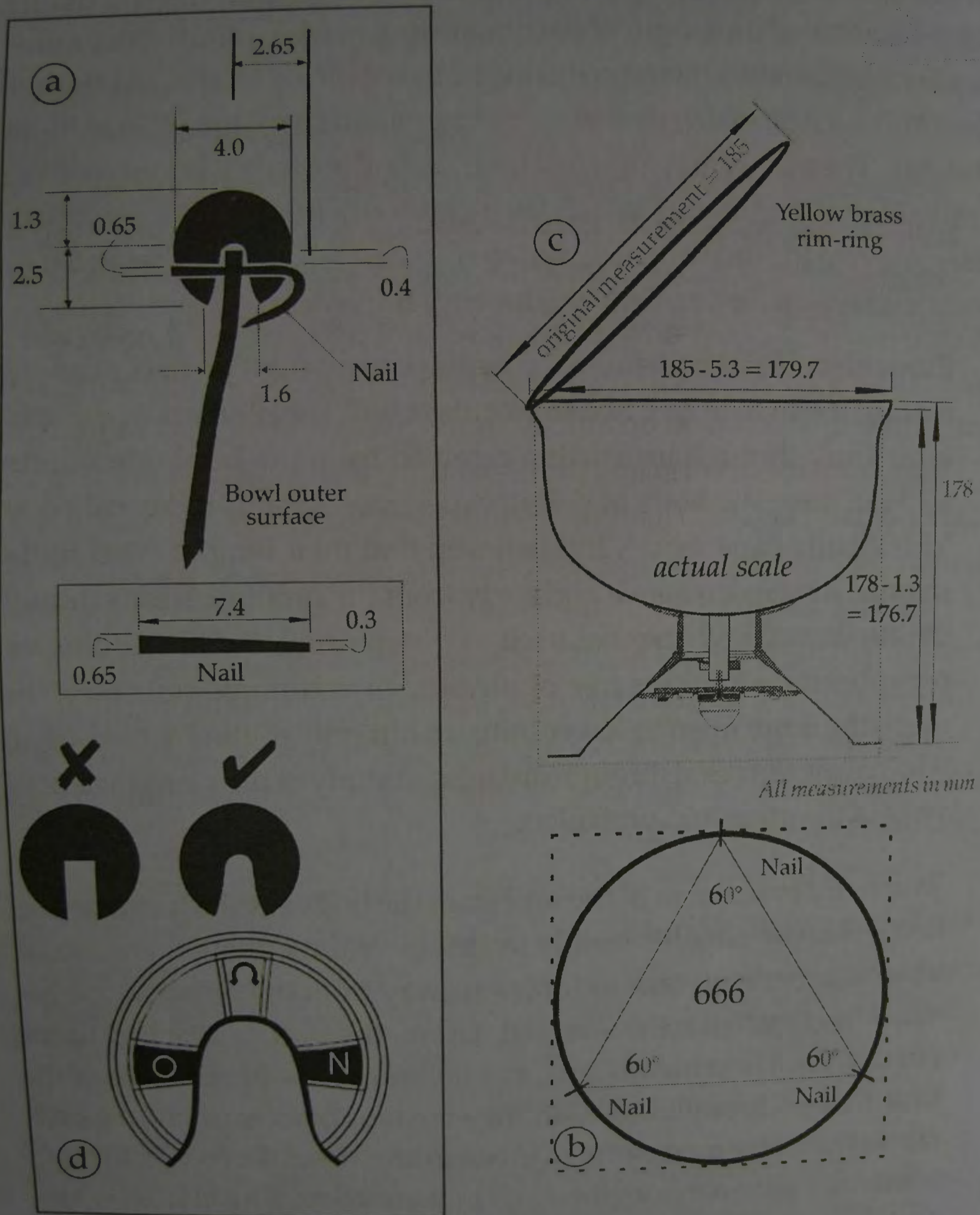

Figure 61. (a) The rim of the chalice has been softened by adding a ring of brass to the lip. A groove is moulded into the brass to provide an imperfect fit with the bowl. The ring is held in place by three tapered brass nails equally spaced (b) around the rim and the bowl and then bent towards the bowl. The distribution accords with the geometric angles of an equilateral triangle (666) the number of the body. When the three nails are removed the ring can be removed from the rim (c). The ratio of the length of the dimensions of the curiously 'not-quite-square' piece now change, reducing from 178mm by 185mm to 176.7mm by 179.7mm [the width decreases by more than twice the change in the height]. Thus by removing the three nails the chalice becomes more 'square'. This describes the esoteric practice of removing the nails of the Crucifixion, enabling the divine nature of man (the soul, or halo—the brass rim-ring) to be released from the body (666), (see main text). (d) The reason for the unusual profile of the groove in the ring and the reason for the wedge-shaped nails now becomes clear.

The Secrets of the Yellow Rim

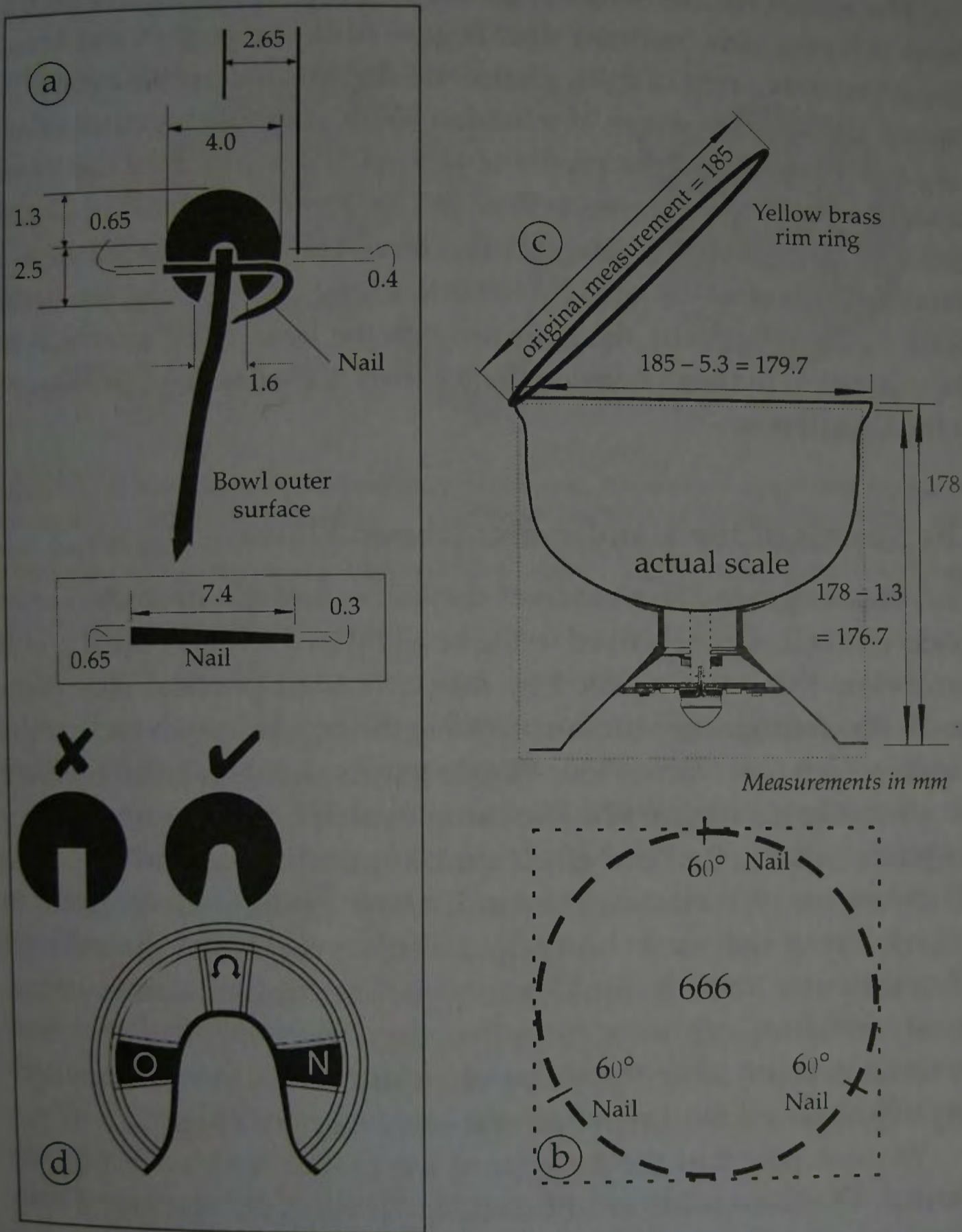

Figure 61. (a) The rim of the chalice has been softened by adding a ring of brass to the lip. A groove is moulded into the brass to provide an imperfect fit with the bowl. The rim is held in place by three tapered brass nails equally spaced (b) around the rim and the bowl and then bent towards the bowl. The distribution accords with the geometric angles of an equilateral triangle (666), the number of the body. When the three nails are removed, the ring can be removed from the rim (c). The ratio of the length of the dimensions of the curiously 'not-quite-square' piece now change, reducing from 178 mm x 185 mm to 176.7 mm x 179.7 mm [the width decreases by more than twice the change in the height]. Thus by removing the three nails the chalice becomes more 'square'. This describes the esoteric practise of removing the nails of the Crucifixion, enabling the divine nature of man (the soul, or halo—the brass rim ring) to be released from the body (666) (see main text). (d) The reason for the unusual profile of the groove in the ring and the reason for the wedge-shaped nails now become clear.

The reason for the unusual profile of the [sloppy] groove in the brass rim ring now becomes clear (figure 61d): the gold-plated brass ring represents a ring of light, a halo, and the unusual profile cut deliberately contains the shape of a human head—the two together referring to a halo around the profile of a human head. Each of the three tapered nails, in this scheme, is thus driven through the head of Christ (through Christ) confirming that the three rim nails (spaced at 60° intervals) represent the nails driven into Christ on the Cross, on Earth (666). At the same time, the nails through the head draw attention to the wounds to the head caused by the crown of thorns that Christ wore at the Crucifixion.

The Secrets of the Handle Escutcheon Plates

Each handle (plate 23) is made of cast silver, heavily decorated with inlaid enamelled panels fixed to the bowl by two rivets at the top and two below that are concealed by four tiny semispherical blue glass studs. The escutcheon plates are fixed to the bowl beneath each of the handles. Each plate carries four filigree panels and three large subconical enamel studs (figure 62). The complex shape of these studs raises suspicion because the bowl girdle studs (figure 51) are finished with a gently convex sectioned-arch shape. If a bowl girdle stud were fired at a body, it may well cause bruising. If a subconical bullet-shaped stud were fired at a body, it would penetrate. The subconical stud immediately becomes *aggressive*. Together, the arrangement of the three escutcheon studs takes the shape of an upside-down equilateral triangle (999) which must represent the soul, or godly, energy.

We now note that the *foot-cone* of the chalice is also subconically shaped. The three studs must therefore represent the aggressive nails hammered into Christ at the Crucifixion, one in each hand and one through the *foot* (feet). The top two are positioned beneath each of the handles, because that is where the studs (the nails) belong, in the hands. The handles are shaped to take one thumb from each hand. Lifting the cup, in this way, forces the palms to embrace the subconical studs, sending the studs (the nails) into the palms of the hands. By raising the cup to the mouth in this way, the recipient participates in a *virtual* Crucifixion and drinks the blood of Christ. By drinking from the

168

The Secrets of the Subconical Studs

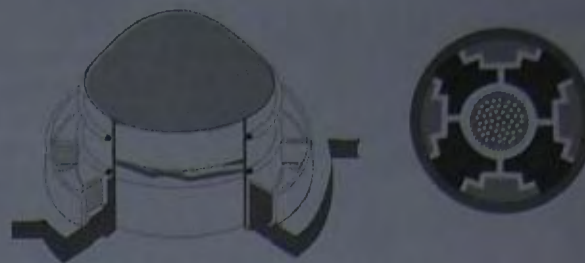

Figure 62. The escutcheon studs are subconically shaped, like the foot-cone. When the thumbs are placed through the handles of the cup and the palms embrace the bowl, the bullet-shaped studs dig into the palms, simulating the nails of the Crucifixion. The triangular arrangement of the three studs refers to the arrangement of nails used in the Crucifixion—one in each hand and one in the foot (-cone). The pattern on the studs takes the shape of a cross with dots in the centre (a cross punctured with holes).

cup the Apostles thus participated in a virtual Crucifixion and drank the blood of Christ at the Last Supper.

Close inspection of the Viracocha vase of Tiahuanaco shows the shape of the handles to be identical to those on the Ardagh Chalice, similarly enabling the lifting of the cup using the thumbs inside the handles, suggesting that the Viracocha vase was the Holy Cup of its day—a later ceramic version of the Holy Grail, left behind by Viracocha in around AD 500. It also means that whoever designed the Ardagh Chalice (the Holy Grail) must have made the Viracocha vase, supporting the fact that Viracocha and Jesus were one and the same spiritual energy.

The subconical studs on the chalice originally contained rings of amber in the channels around the mount, associating the studs with electromagnetic energy, the soul and the Sun.

The Derrynaflan Hoard

The Derrynaflan hoard, consisting of a large silver chalice (figure 63), a silver paten, a hoop (that may have been a stand for the paten), a copper alloy strainer-ladle, and a copper-alloy basin, was found on the

169

The Secrets of the Subconical Studs

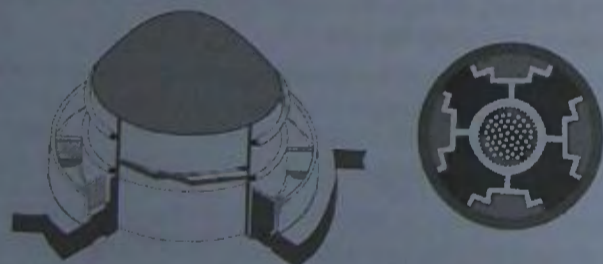

Figure 62. The escutcheon studs are subconically shaped, like the foot-cone. When the thumbs are placed through the handles of the cup and the palms embrace the bowl the bullet-shaped studs dig into the palms, simulating the nails of the Crucifixion. The triangular arrangement of the three studs refers to the arrangement of nails used in the Crucifixion—one in each hand and one in the foot (-cone). The pattern on the studs takes the shape of a cross punctured with holes.

The Derrynaflan Hoard



Figure 63. The Derrynaflan hoard including chalice, wine strainer, paten (with inner ring) and bowl.

170

We now note that the *foot-cone* of the chalice is also subconically shaped. The three studs must therefore represent the aggressive nails hammered into Christ at the Crucifixion, one in each hand and one through the *foot* (feet). The top two are positioned beneath each of the handles, because that is where the studs (the nails) belong, in the hands. The handles are shaped to take one thumb from each hand. Lifting the cup, in this way, forces the palms to embrace the sub-conical studs, sending the studs (the nails) into the palms of the hands. By raising the cup to the mouth in this way the recipient participates in a *virtual* Crucifixion and drinks the blood of Christ. By drinking from the cup the Apostles thus participated in a virtual Crucifixion and drank the blood of Christ at the Last Supper.

Close inspection of the Viracocha vase of Tiahuanaco shows the shape of the handles to be identical to those on the Ardagh Chalice similarly enabling the lifting of the cup using the thumbs inside the handles suggesting that the Viracocha vase was the Holy Cup of its day—a later ceramic version of the Holy Grail, left behind by Viracocha in around AD 500. It also means that whoever designed the Ardagh Chalice (the Holy Grail) must have made the Viracocha vase, supporting the fact that Viracocha and Jesus were one and the same spiritual energy.

The sub-conical studs on the chalice originally contained rings of amber in the channels around the mount associating the studs with electromagnetic energy, the soul and the Sun.

The Derrynaflan Hoard

The Derrynaflan Hoard, comprising of a large silver chalice (figure 63); a silver paten, a hoop (that may have been a stand for the paten), a copper alloy strainer-ladle, and a copper-alloy basin, was found on the monastic site of Derrynaflan, County Tipperary, in 1980, in a covered pit by a man using a metal detector.

The Chalice is a two-handled ministerial vessel which some compare to the Ardagh Chalice, although it is much more Byzantine in style. It has filigree decoration around the bowl but the decorative girdle differs substantially from the construction of the Ardagh Chalice.

The paten, described as a communion plate, is a highly polished concave silver plate with a diameter of 370mm (14.5 inches). The top and sides are heavily decorated with twenty four bronze stud mounts with

171

The Secrets of the Subconical Studs

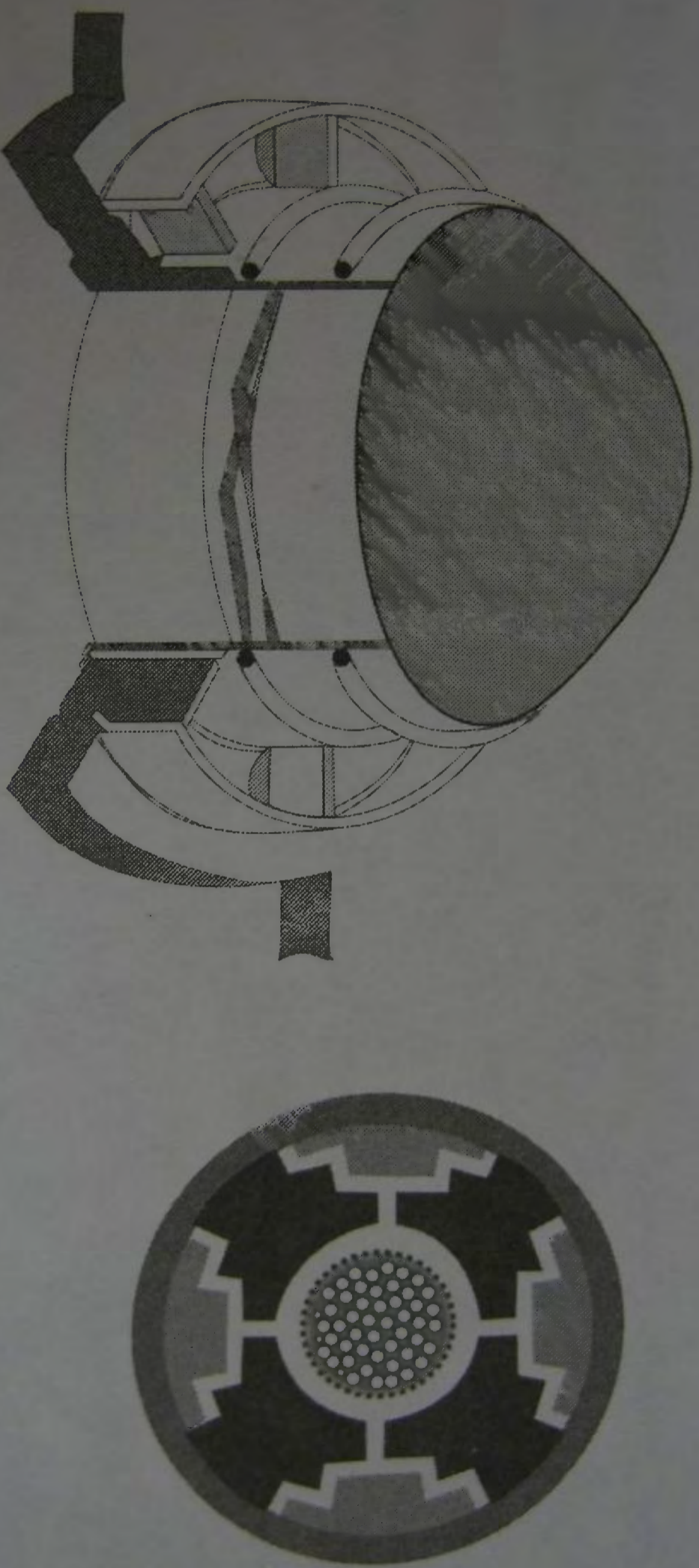

Figure 62. The escutcheon studs are subconically shaped, like the foot-cone. When the thumbs are placed through the handles of the cup and the palms embrace the bowl, the bullet-shaped studs dig into the palms, simulating the nails of the Crucifixion. The triangular arrangement of the three studs refers to the arrangement of nails used in the Crucifixion—one in each hand and one in the foot (-cone). The pattern on the studs takes the shape of a cross with dots in the centre (a cross punctured with holes).

cup the Apostles thus participated in a virtual Crucifixion and drank

The Secrets of the Subconical Studs

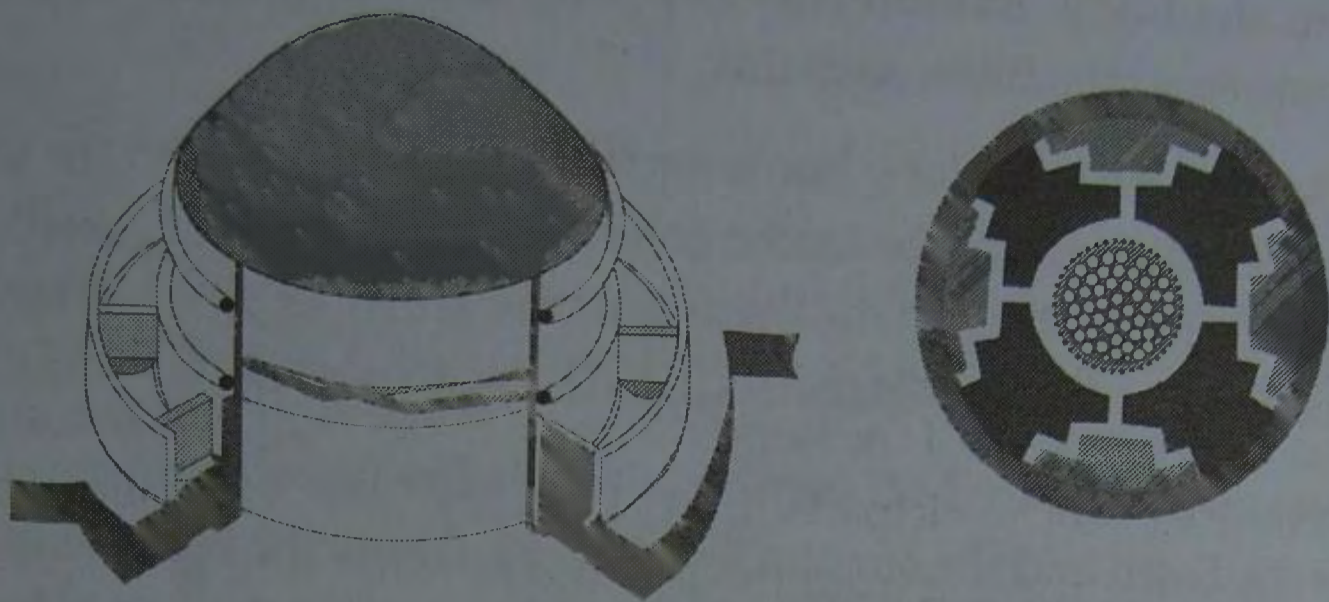

Figure 62. The escutcheon studs are subconically shaped, like the foot-cone. When the thumbs are placed through the handles of the cup and the palms embrace the bowl the bullet-shaped studs dig into the palms, simulating the nails of the Crucifixion. The tri-angular arrangement of the three studs refers to the arrangement of nails used in the Crucifixion—one in each hand and one in the foot (-cone). The pattern on the studs takes the shape of a cross with dots in the centre (a cross punctured with holes).

The Derrynaflan Hoard



Figure 63. The Derrynaflan hoard including chalice, wine strainer, paten (with inner ring) and bowl.

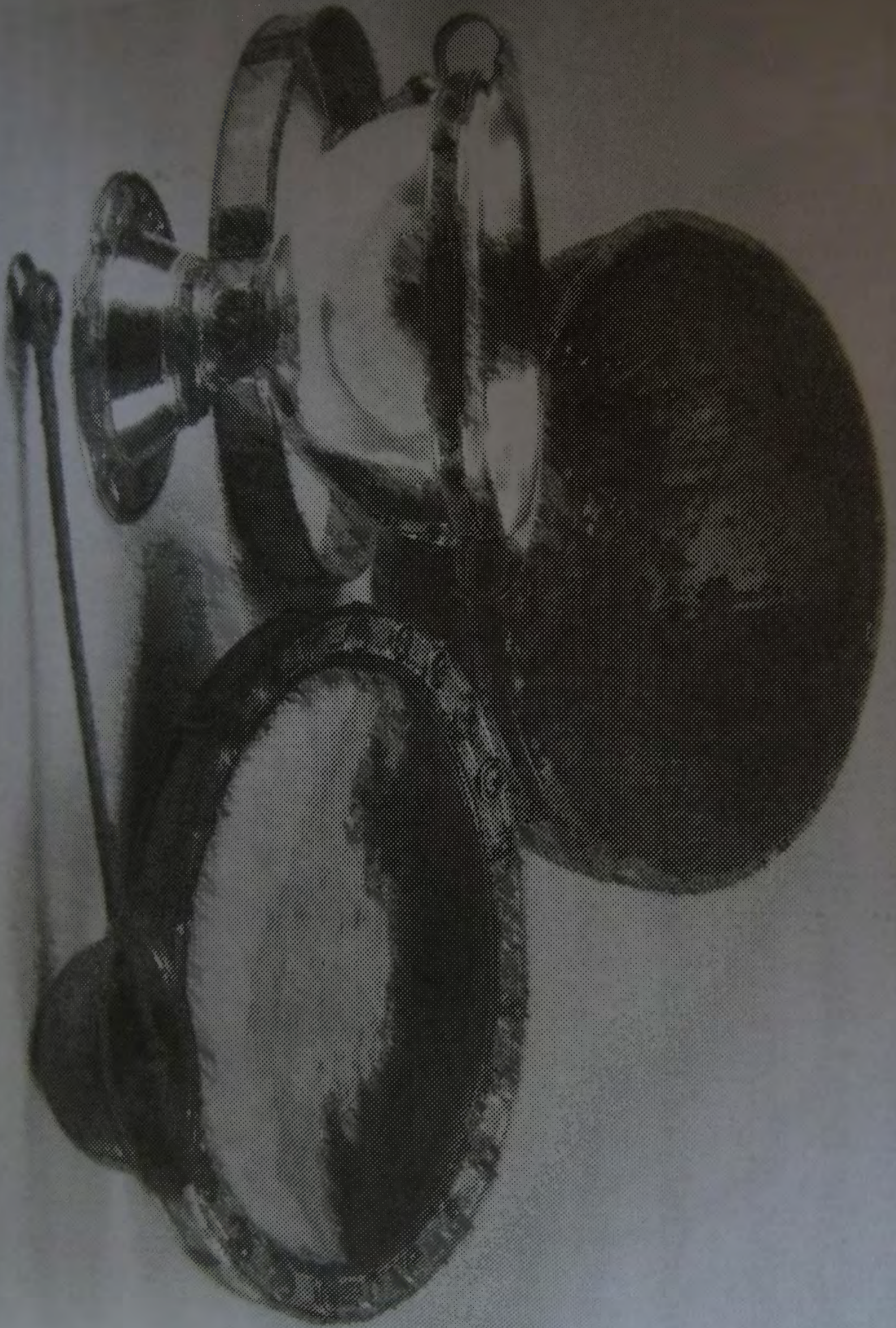

Figure 63. The Derrynaflan hoard including chalice, wine strainer, paten (with inner ring) and bowl.

The Derrynaflan Hoard



Figure 63. The Derrynaflan hoard including chalice, wine strainer, paten (with inner ring) and bowl.

monastic site of Derrynaflan, County Tipperary, in 1980, in a covered pit by a man using a metal detector.

The chalice is a two-handled ministerial vessel which some compare to the Ardagh Chalice, although it is much more Byzantine in style. It has filigree decoration around the bowl but the decorative girdle differs substantially from the construction of the Ardagh Chalice.

The paten, described as a communion plate, is a highly polished concave silver plate with a diameter of 370 mm (14.5 inches). The top and sides are heavily decorated with twenty-four bronze stud mounts with enamelled studs and filigree panels. The sides are covered in knitted silver and copper wires that carry filigree panels interspersed with decorative square stud mounts and studs. The paten was made to sit on a rim, raising it 30 mm (1.25 inches) off the resting surface, enabling the paten to be lifted without crushing the sides.

The wine strainer-ladle was made by adding a pierced-metal plate

to a long-handle ladle. The ladle carries a semispherical rock crystal at the handle end.

At a glance the quality and craftsmanship appear comparable to that of the Ardagh Chalice and it is tempting to suggest that they may have originated in the same workshop. But the Derrynaflan pieces contain none of the esoteric knowledge that is to be found in the Ardagh Chalice. The bowl girdle is much simpler than that of the Ardagh Chalice and although it carries twelve decorative studs, they are made of simple square amber pieces set in square mounts, rather than enamelled glass. The bowl girdle panels are manufactured differently—they are much simpler, manufactured using a simple flat backplate decorated with wire, not fabricated from an embossed openwork plate supported by a backplate. The handles are lighter in construction, and smaller—less likely to accommodate a thumb. It too has an escutcheon plate, beneath the handles, but again the structure is lighter and the three amber studs are simple and semispherical, rather than complex and subconical, meaning that although it could be used to drink from, it could never be used to emulate a *virtual* crucifixion.

The foot-cone is not subconical in shape. The foot flange accommodates a continuous ring of filigree that is punctuated with four square and four semispherical amber studs. Above this, on the shoulder of the cone, runs a shoulder girdle decorated with filigree wire panels punctuated by eight square amber studs. It has clearly been made by someone wishing to copy a work of quality without the necessary intellectual input required to encode esoteric knowledge into the design—the sunspot cycle could never be calculated using just two squares (4, 4) and one octagonal (8) shape.

The bowl lip, or rim, has been spun into shape; it does not carry a separate rim ring, or halo. Indeed everything about it is of a different nature from the Ardagh Chalice. But perhaps it was made by the same hand and meant to be that way, to paint a distinction between the real thing and imitations, which, although valuable, beautiful, and useful, belong in a different league altogether.

It is tempting to imagine the 19.2 cm (7.5-inch) Derrynaflan chalice was used at the Last Supper, to ladle the wine into the Ardagh Chalice. The volumetric capacity of both chalices is about the same. The ladle could have made a difference by straining wine kept in the

The Secrets of the Subconical Studs

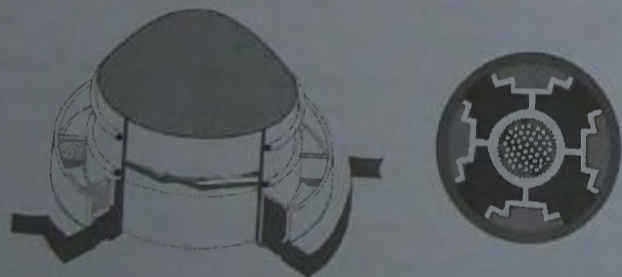

Figure 62. The escutcheon studs are subconically shaped, like the foot-cone. When the thumbs are placed through the handles of the cup and the palms embrace the bowl the bullet-shaped studs dig into the palms, simulating the nails of the Crucifixion. The triangular arrangement of the three studs refers to the arrangement of nails used in the Crucifixion—one in each hand and one in the foot (-cone). The pattern on the studs takes the shape of a cross with dots in the centre.

The Derrynaflan Hoard



Figure 63. The Derrynaflan hoard including chalice, wine strainer, paten (with inner ring) and bowl.

We now note that the *foot*-cone of the chalice is also subconically shaped. The three studs must therefore represent the aggressive nails hammered into Christ at the Crucifixion, one in each hand and one through the *foot* (feet). The top two are positioned beneath each of the handles, because that is where the studs (the nails) belong, in the hands. The handles are shaped to take one thumb from each hand. Lifting the cup, in this way, forces the palms to embrace the sub-conical studs, sending the studs (the nails) into the palms of the hands. By raising the cup to the mouth in this way the recipient participates in a *virtual* Crucifixion and drinks the blood of Christ. By drinking from the cup the Apostles thus participated in a *virtual* Crucifixion and drank the blood of Christ at the Last Supper.

Close inspection of the Viracocha vase of Tiahuanaco shows the shape of the handles to be identical to those on the Ardagh Chalice similarly enabling the lifting of the cup using the thumbs inside the handles suggesting that the Viracocha vase was the Holy Cup of its day—a later ceramic version of the Holy Grail, left behind by Viracocha in around AD 500. It also means that whoever designed the Ardagh Chalice (the Holy Grail) must have made the Viracocha vase, supporting the fact that Viracocha and Jesus were one and the same spiritual energy.

The sub-conical studs on the chalice originally contained rings of amber in the channels around the mount associating the studs with electromagnetic energy, the soul and the Sun.

The Derrynaflan Haul

The Derrynaflan Hoard, comprising of a large silver chalice (figure 63); a silver paten, a hoop (that may have been a stand for the paten), a copper alloy strainer-ladle, and a copper-alloy basin, was found on the monastic site of Derrynaflan, County Tipperary, in 1980, in a covered pit by a man using a metal detector.

The Chalice is a two-handled ministerial vessel which some compare to the Ardagh Chalice, although it is much more Byzantine in style. It has filigree decoration around the bowl but the decorative girdle differs substantially from the construction of the Ardagh Chalice.

The paten, described as a communion plate, is a highly polished concave silver plate with a diameter of 370mm (14.5 inches). The top and sides are heavily decorated with twenty-four bronze stud mounts with

The Derrynaflan Hoard



Figure 63. The Derrynaflan hoard including chalice, wine strainer, paten (with inner ring) and bowl.

monastic site of Derrynaflan, County Tipperary, in 1980, in a covered pit by a man using a metal detector.

The chalice is a two-handled ministerial vessel which some compare to the Ardagh Chalice, although it is much more Byzantine in style. It has filigree decoration around the bowl but the decorative girdle differs substantially from the construction of the Ardagh Chalice.

The paten, described as a communion plate, is a highly polished concave silver plate with a diameter of 370 mm (14.5 inches). The top and sides are heavily decorated with twenty-four bronze stud mounts with enamelled studs and filigree panels. The sides are covered in knitted silver and copper wires that carry filigree panels interspersed with decorative square stud mounts and studs. The paten was made to sit on a rim, raising it 30 mm (1.25 inches) off the resting surface, enabling the paten to be lifted without crushing the sides.

The wine strainer-ladle was made by adding a pierced-metal plate

to a long-handle ladle. The ladle carries a semispherical rock crystal at the handle end.

At a glance the quality and craftsmanship appear comparable to that of the Ardagh Chalice and it is tempting to suggest that they may have originated in the same workshop. But the Derrynaflan pieces contain none of the esoteric knowledge that is to be found in the Ardagh Chalice. The bowl girdle is much simpler than that of the Ardagh Chalice and although it carries twelve decorative studs, they are made of simple square amber pieces set in square mounts, rather than enamelled glass. The bowl girdle panels are manufactured differently—they are much simpler, manufactured using a simple flat backplate decorated with wire, not fabricated from an embossed openwork plate supported by a backplate. The handles are lighter in construction, and smaller—less likely to accommodate a thumb. It too has an escutcheon plate, beneath the handles, but again the structure is lighter and the three amber studs are simple and semispherical, rather than complex and subconical, meaning that although it could be used to drink from, it could never be used to emulate a *virtual* crucifixion.

The foot-cone is not subconical in shape. The foot flange accommodates a continuous ring of filigree that is punctuated with four square and four semispherical amber studs. Above this, on the shoulder of the cone, runs a shoulder girdle decorated with filigree wire panels punctuated by eight square amber studs. It has clearly been made by someone wishing to copy a work of quality without the necessary intellectual input required to encode esoteric knowledge into the design—the sunspot cycle could never be calculated using just two squares (4, 4) and one octagonal (8) shape.

The bowl lip, or rim, has been spun into shape; it does not carry a separate rim ring, or halo. Indeed everything about it is of a different nature from the Ardagh Chalice. But perhaps it was made by the same hand and meant to be that way, to paint a distinction between the real thing and imitations, which, although valuable, beautiful, and useful, belong in a different league altogether.

It is tempting to imagine the 19.2 cm (7.5-inch) Derrynaflan chalice was used at the Last Supper, to ladle the wine into the Ardagh Chalice. The volumetric capacity of both chalices is about the same. The ladle could have made a difference by straining wine kept in the

enamelled studs and filigree panels. The sides are covered in knitted silver and copper wire that carry filigree panels interspersed with decorative square stud mounts and studs. The paten was made to sit on a rim, raising it 30 mm (1.25 inches) off the resting surface, enabling the paten to be lifted without crushing the sides.

The wine strainer-ladle was made by adding a pierced-metal plate to a long-handle ladle. The ladle carries a semispherical rock crystal at the handle end.

At a glance the quality and craftsmanship appear comparable to that of the Ardagh Chalice and it is tempting to suggest that they may have originated in the same workshop. But the Derrynaflan pieces contain none of the esoteric knowledge that is to be found in the Ardagh Chalice. The bowl girdle is much simpler than that of the Ardagh Chalice and although it carries twelve decorative studs they are made of simple square amber pieces set in square mounts, rather than enamelled glass. The bowl girdle panels are manufactured differently—they are much simpler; manufactured using a simple flat back-plate decorated with wire, not fabricated from an embossed openwork plate supported by a back-plate. The handles are lighter in construction, and smaller—less likely to accommodate a thumb. It too has an escutcheon plate, beneath the handles, but again the structure is lighter and the three amber studs are simple and semispherical, rather than complex and subconical, meaning that although it could be used to drink from it could never be used to emulate a *virtual* crucifixion.

The foot-cone is not subconical in shape. The foot flange accommodates a continuous ring of filigree that is punctuated with four square and four semispherical amber studs. Above this, on the shoulder of the cone, runs a shoulder girdle decorated with filigree wire panels punctuated by eight square amber studs. It has clearly been made by someone wishing to copy a work of quality without the necessary intellectual input required to encode esoteric knowledge into the design—the sunspot cycle could never be calculated using just two squares (4, 4) and one octagonal (8) shape.

The bowl lip, or rim, has been spun into shape; it does not carry a separate rim-ring, or halo. Indeed everything about it is of a different nature to the Ardagh Chalice. But perhaps it was made by the same hand

and meant to be that way, to paint a distinction between the real thing and imitations which although valuable, beautiful, and useful, belong in a different league altogether.

It is tempting to imagine the 19.2cm- (7.5-inch-) high Derrynaflan Chalice was used at the Last Supper, to ladle the wine into the Ardagh Chalice. The volumetric capacity of both chalices is about the same. The ladle could have made a difference by straining wine kept in the 'impure' Derrynaflan Chalice into the 'purified' Ardagh Chalice. If it was, it might have accompanied the Holy Grail on its journey. But if it was used to simply strain wine, then the Derrynaflan Chalice would never have been touched by Christ (only by a ladle) nor would Christ have drunk from it, meaning that it never held the Eucharistic blood of Christ. There are other major differences that set the two pieces apart; the Derrynaflan Chalice does not carry the names of the Apostles; it has not been engraved suggesting a pedigree going back to before AD 453 and it does not contain the super-science of the Sun or the higher orders of spirituality.

The Copycat Monks

For the Ardagh Chalice to be the Holy Grail it must clearly be much older than current expert opinion believes it to be—AD 26 rather than AD 700—and herein lies the crux of the enquiry.

Nowadays, dating of organic antiquities can be established using the Carbon 14 dating method. But the method is confined to organic material. The Ardagh Chalice and the Tara Brooch do not contain any organic material, apart from Amber, which is known to be millions of years old and therefore irrelevant for purposes of dating the manufacture of the pieces. In cases such as this archaeologists look for organic compounds found near the artefact from which a 'date-by-association' can be obtained, for example charcoal from an old fireplace. Dating of the charcoal then sets a minimum age for dating the non-organic artefact. But there are no accompanying organic materials to help date the pieces by association [notwithstanding the fact that the Ardagh Chalice was found together with four brooches which, as previously discussed, bear no esoteric resemblance to the Tara Brooch, they are simply cheap seventh- or eighth-century copies of the Tara Brooch which was revered by clerics]. This said, it is perfectly understandable that archaeologists should choose to

'impure' Derrynaflan chalice into the 'purified' Ardagh Chalice. If it was, it might have accompanied the Holy Grail on its journey. But if it was used to simply strain wine, then the Derrynaflan chalice would never have been touched by Christ (only by a ladle) nor would Christ have drunk from it, meaning that it never held the Eucharistic blood of Christ. There are other major differences that set the two pieces apart: the Derrynaflan chalice does not carry the names of the Apostles; it has not been engraved, suggesting a pedigree going back to before AD 453, and it does not contain the super-science of the Sun or the higher orders of spirituality.

The Copycat Monks

For the Ardagh Chalice to be the Holy Grail it must clearly be much older than current expert opinion believes it to be—AD 26 rather than AD 700—and herein lies the crux of the enquiry.

Nowadays, dating of organic antiquities can be established using the carbon 14 dating method. But the method is confined to organic material. The Ardagh Chalice and the Tara brooch do not contain any organic material, apart from amber, which is known to be millions of years old and therefore irrelevant for purposes of dating the manufacture of the pieces. In cases such as this, archaeologists look for organic compounds found near the artefact from which a 'date-by-association' can be obtained—for example, charcoal from an old fireplace. Dating of the charcoal then sets a minimum age for dating the non-organic artefact. But there are no accompanying organic materials to help date the pieces by association [notwithstanding the fact that the Ardagh Chalice was found together with four brooches which, as previously discussed, bear no esoteric resemblance to the Tara brooch; they are simply cheap seventh- or eighth-century copies of the Tara brooch which was revered by clerics]. This said, it is perfectly understandable that archaeologists should choose to date the chalice by association with the pretenders with which it was found and likewise understandable that the date could be so far removed from the truth.

To further substantiate their argument the experts fall back on the similarities in the style of the Ardagh Chalice, the Tara brooch and illuminated manuscripts, maintaining that the similarities demand that

they must all be from the same period: insisting, for example (as we have already heard) that the insular majuscule text on the chalice is identical to that used in the Lindisfarne Gospels of AD 698 and therefore that the date is common to them all. And who could dispute that dozens of similarities can be found among the chalice, the Tara brooch and the illuminated manuscripts?

But association is a double-edged sword that begs the question of which came first, the chicken or the egg, the chalice or the manuscripts? Did the illuminated manuscripts inspire the production of the chalice and the Tara brooch? Or did the chalice and the Tara brooch inspire the production of the manuscripts?

The insular majuscule engraving on the chalice is not identical to that in the Lindisfarne Gospels as experts claim. It is rough and crude, as though to suggest that it might have been carved with a nail.

Generally speaking (in an engineering sense) any prototype model (or manuscript) is crude and unsophisticated. Subsequent models become more refined over time until the near-perfect finished product emerges ready for the market. The insular majuscule text in the Lindisfarne Gospels is neat, refined and near perfect, suggesting that the chalice came first and that whoever compiled the manuscript had plenty of writing practise before the manuscript was ready.

The evidence does not end there. The illuminated manuscripts contain other glaring similarities that are just *too obvious* if the official line is followed: consider the geometric shapes from the illustrations in figures 46, 47, 48, 50, 51, 60, 61 and 62. A few of these geometric line drawings are reproduced in figure 64 alongside corollary pattern designs from the books of Kells and Lindisfarne. The comparison is revealing and begs the question 'why would anyone create a manuscript containing such oddly specific geometric shapes, shapes that are all found prolifically in the Ardagh Chalice?' There would be no point in picking geometric shapes out of thin air, filling them with Celtic designs and including them in the most valued manuscripts ever written. The fact that they used the shapes is evidence that they had a *reason* for using them, because they *revered* them. The reason they revered them was that the shapes are found in the most important relic of the Christian Church, the Holy Grail. It was not the other way round. Can you imagine the most senior monk in a scriptorium

enamelled studs and filigree panels. The sides are covered in knitted silver and copper wire that carry filigree panels interspersed with decorative square stud mounts and studs. The paten was made to sit on a rim, raising it 30mm (1.25 inches) off the resting surface, enabling the paten to be lifted without crushing the sides.

The wine strainer-ladle was made by adding a pierced-metal plate to a long-handle ladle. The ladle carries a semispherical rock crystal at the handle end.

At a glance the quality and craftsmanship appear comparable to that of the Ardagh Chalice and it is tempting to suggest that they may have originated in the same workshop. But the Derrynaflan pieces contain none of the esoteric knowledge that is to be found in the Ardagh Chalice. The bowl girdle is much simpler than that of the Ardagh Chalice and although it carries twelve decorative studs they are made of simple square amber pieces set in square mounts, rather than enamelled glass. The bowl girdle panels are manufactured differently—they are much simpler: manufactured using a simple flat back-plate decorated with wire, not fabricated from an embossed openwork plate supported by a back-plate. The handles are lighter in construction, and smaller—less likely to accommodate a thumb. It too has an escutcheon plate, beneath the handles, but again the structure is lighter and the three amber studs are simple and semispherical, rather than complex and subconical, meaning that although it could be used to drink from it could never be used to emulate a *virtual* crucifixion.

The foot-cone is not subconical in shape. The foot flange accommodates a continuous ring of filigree that is punctuated with four square and four semispherical amber studs. Above this, on the shoulder of the cone, runs a shoulder girdle decorated with filigree wire panels punctuated by eight square amber studs. It has clearly been made by someone wishing to copy a work of quality without the necessary intellectual input required to encode esoteric knowledge into the design—the sunspot cycle could never be calculated using just two squares (4, 4) and one octagonal (8) shape.

The bowl lip, or rim, has been spun into shape; it does not carry a separate rim-ring, or halo. Indeed everything about it is of a different *nature* to the Ardagh Chalice. But perhaps it was made by the same hand

and meant to be that way, to paint a distinction between the real thing and imitations which although valuable, beautiful, and useful, belong in a different league altogether.

It is tempting to imagine the 19.2cm- (7.5-inch-) high Derrynaflan Chalice was used at the Last Supper, to ladle the wine into the Ardagh Chalice. The volumetric capacity of both chalices is about the same. The ladle could have made a difference by straining wine kept in the 'impure' Derrynaflan Chalice into the 'purified' Ardagh Chalice. If it was, it might have accompanied the Holy Grail on its journey. But if it was used to simply strain wine, then the Derrynaflan Chalice would never have been touched by Christ (only by a ladle) nor would Christ have drunk from it, meaning that it never held the Eucharistic blood of Christ. There are other major differences that set the two pieces apart: the Derrynaflan Chalice does not carry the names of the Apostles; it has not been engraved suggesting a pedigree going back to before AD 453 and it does not contain the super-science of the Sun or the higher orders of spirituality.

The Copycat Monks

For the Ardagh Chalice to be the Holy Grail it must clearly be much older than current expert opinion believes it to be—AD 26 rather than AD 700—and herein lies the crux of the enquiry.

Nowadays, dating of organic antiquities can be established using the Carbon 14 dating method. But the method is confined to organic material. The Ardagh Chalice and the Tara Brooch do not contain any organic material, apart from Amber, which is known to be millions of years old and therefore irrelevant for purposes of dating the manufacture of the pieces. In cases such as this archaeologists look for organic compounds found near the artefact from which a 'date-by-association' can be obtained, for example charcoal from an old fireplace. Dating of the charcoal then sets a minimum age for dating the non-organic artefact. But there are no accompanying organic materials to help date the pieces by association [notwithstanding the fact that the Ardagh Chalice was found together with four brooches which, as previously discussed, bear no esoteric resemblance to the Tara Brooch, they are simply cheap seventh- or eighth-century copies of the Tara Brooch which was revered by clerics]. This said, it is perfectly understandable that archaeologists should choose to

'impure' Derrynaflan chalice into the 'purified' Ardagh Chalice. If it was, it might have accompanied the Holy Grail on its journey. But if it was used to simply strain wine, then the Derrynaflan chalice would never have been touched by Christ (only by a ladle) nor would Christ have drunk from it, meaning that it never held the Eucharistic blood of Christ. There are other major differences that set the two pieces apart: the Derrynaflan chalice does not carry the names of the Apostles; it has not been engraved, suggesting a pedigree going back to before AD 453, and it does not contain the super-science of the Sun or the higher orders of spirituality.

The Copycat Monks

For the Ardagh Chalice to be the Holy Grail it must clearly be much older than current expert opinion believes it to be—AD 26 rather than AD 700—and herein lies the crux of the enquiry.

Nowadays, dating of organic antiquities can be established using the carbon 14 dating method. But the method is confined to organic material. The Ardagh Chalice and the Tara brooch do not contain any organic material, apart from amber, which is known to be millions of years old and therefore irrelevant for purposes of dating the manufacture of the pieces. In cases such as this, archaeologists look for organic compounds found near the artefact from which a 'date-by-association' can be obtained—for example, charcoal from an old fireplace. Dating of the charcoal then sets a minimum age for dating the non-organic artefact. But there are no accompanying organic materials to help date the pieces by association [notwithstanding the fact that the Ardagh Chalice was found together with four brooches which, as previously discussed, bear no esoteric resemblance to the Tara brooch; they are simply cheap seventh- or eighth-century copies of the Tara brooch which was revered by clerics]. This said, it is perfectly understandable that archaeologists should choose to date the chalice by association with the pretenders with which it was found and likewise understandable that the date could be so far removed from the truth.

To further substantiate their argument the experts fall back on the similarities in the style of the Ardagh Chalice, the Tara brooch and illuminated manuscripts, maintaining that the similarities demand that

they must all be from the same period: insisting, for example (as we have already heard) that the insular majuscule text on the chalice is identical to that used in the Lindisfarne Gospels of AD 698 and therefore that the date is common to them all. And who could dispute that dozens of similarities can be found among the chalice, the Tara brooch and the illuminated manuscripts?

But association is a double-edged sword that begs the question of which came first, the chicken or the egg, the chalice or the manuscripts? Did the illuminated manuscripts inspire the production of the chalice and the Tara brooch? Or did the chalice and the Tara brooch inspire the production of the manuscripts?

The insular majuscule engraving on the chalice is not identical to that in the Lindisfarne Gospels as experts claim. It is rough and crude, as though to suggest that it might have been carved with a nail.

Generally speaking (in an engineering sense) any prototype model (or manuscript) is crude and unsophisticated. Subsequent models become more refined over time until the near-perfect finished product emerges ready for the market. The insular majuscule text in the Lindisfarne Gospels is neat, refined and near perfect, suggesting that the chalice came first and that whoever compiled the manuscript had plenty of writing practise before the manuscript was ready.

The evidence does not end there. The illuminated manuscripts contain other glaring similarities that are just *too obvious* if the official line is followed: consider the geometric shapes from the illustrations in figures 46, 47, 48, 50, 51, 60, 61 and 62. A few of these geometric line drawings are reproduced in figure 64 alongside corollary pattern designs from the books of Kells and Lindisfarne. The comparison is revealing and begs the question 'why would anyone create a manuscript containing such oddly specific geometric shapes, shapes that are all found prolifically in the Ardagh Chalice?' There would be no point in picking geometric shapes out of thin air, filling them with Celtic designs and including them in the most valued manuscripts ever written. The fact that they used the shapes is evidence that they had a reason for using them, because they *revered* them. The reason they revered them was that the shapes are found in the most important relic of the Christian Church, the Holy Grail. It was not the other way round. Can you imagine the most senior monk in a scriptorium

enamelled studs and filigree panels. The sides are covered in knitted silver and copper wire that carry filigree panels interspersed with decorative square stud mounts and studs. The paten was made to sit on a rim, raising it 30mm (1.25 inches) off the resting surface, enabling the paten to be lifted without crushing the sides.

The wine strainer-ladle was made by adding a pierced-metal plate to a long-handle ladle. The ladle carries a semispherical rock crystal at the handle end.

At a glance the quality and craftsmanship appear comparable to that of the Ardagh Chalice and it is tempting to suggest that they may have originated in the same workshop. But the Derrynaflan pieces contain none of the esoteric knowledge that is to be found in the Ardagh Chalice. The bowl girdle is much simpler than that of the Ardagh Chalice and although it carries twelve decorative studs they are made of simple square amber pieces set in square mounts, rather than enamelled glass. The bowl girdle panels are manufactured differently—they are much simpler; manufactured using a simple flat back-plate decorated with wire, not fabricated from an embossed openwork plate supported by a back-plate. The handles are lighter in construction, and smaller—less likely to accommodate a thumb. It too has an escutcheon plate, beneath the handles, but again the structure is lighter and the three amber studs are simple and semispherical, rather than complex and subconical, meaning that although it could be used to drink from it could never be used to emulate a *virtual* crucifixion.

The foot-cone is not subconical in shape. The foot flange accommodates a continuous ring of filigree that is punctuated with four square and four semispherical amber studs. Above this, on the shoulder of the cone, runs a shoulder girdle decorated with filigree wire panels punctuated by eight square amber studs. It has clearly been made by someone wishing to copy a work of quality without the necessary intellectual input required to encode esoteric knowledge into the design—the sunspot cycle could never be calculated using just two squares (4, 4) and one octagonal (8) shape.

The bowl lip, or rim, has been spun into shape; it does not carry a separate rim-ring, or halo. Indeed everything about it is of a different nature to the Ardagh Chalice. But perhaps it was made by the same hand

and meant to be that way, to paint a distinction between the real thing and imitations which although valuable, beautiful, and useful, belong in a different league altogether.

It is tempting to imagine the 19.2cm (7.5-inch-) high Derrynaflan Chalice was used at the Last Supper, to ladle the wine into the Ardagh Chalice. The volumetric capacity of both chalices is about the same. The ladle could have made a difference by straining wine kept in the 'impure' Derrynaflan Chalice into the 'purified' Ardagh Chalice. If it was, it might have accompanied the Holy Grail on its journey. But if it was used to simply strain wine, then the Derrynaflan Chalice would never have been touched by Christ (only by a ladle) nor would Christ have drunk from it, meaning that it never held the Eucharistic blood of Christ. There are other major differences that set the two pieces apart: the Derrynaflan Chalice does not carry the names of the Apostles; it has not been engraved suggesting a pedigree going back to before AD 453 and it does not contain the super-science of the Sun or the higher orders of spirituality.

The Copycat Monks

For the Ardagh Chalice to be the Holy Grail it must clearly be much older than current expert opinion believes it to be—AD 26 rather than AD 700—and herein lies the crux of the enquiry.

Nowadays, dating of organic antiquities can be established using the Carbon 14 dating method. But the method is confined to organic material. The Ardagh Chalice and the Tara Brooch do not contain any organic material, apart from Amber, which is known to be millions of years old and therefore irrelevant for purposes of dating the manufacture of the pieces. In cases such as this archaeologists look for organic compounds found near the artefact from which a 'date-by-association' can be obtained, for example charcoal from an old fireplace. Dating of the charcoal then sets a minimum age for dating the non-organic artefact. But there are no accompanying organic materials to help date the pieces by association [notwithstanding the fact that the Ardagh Chalice was found together with four brooches which, as previously discussed, bear no esoteric resemblance to the Tara Brooch, they are simply cheap seventh- or eighth-century copies of the Tara Brooch which was revered by clerics]. This said, it is perfectly understandable that archaeologists should choose to

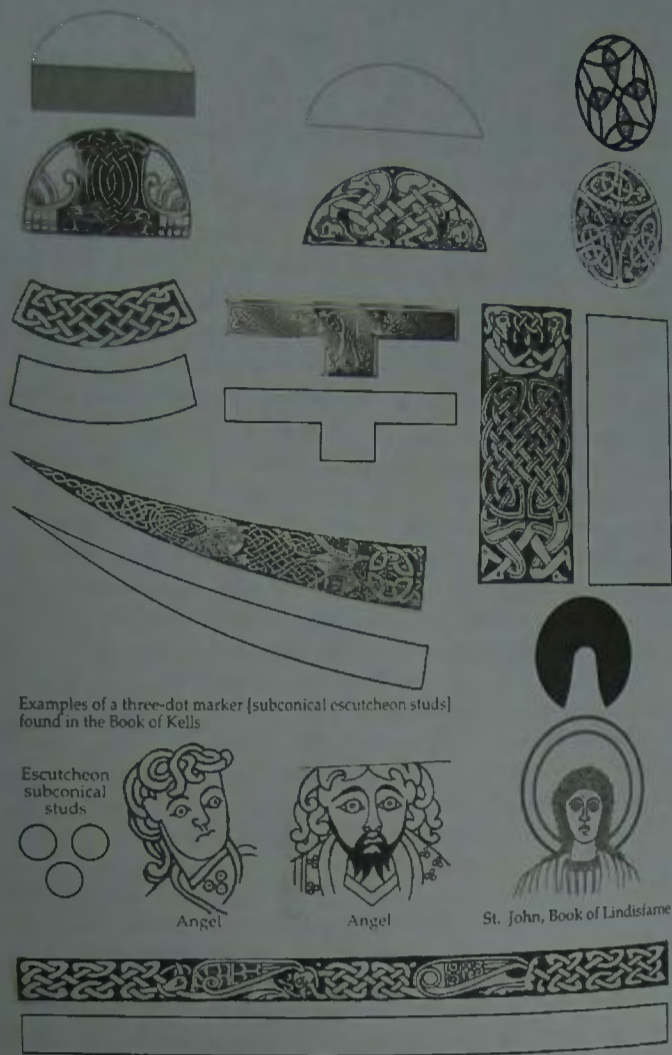

Examples of a three-dot marker [subconical escutcheon studs] found in the Book of Kells

Escutcheon subconical studs



Figure 64. Comparison of geometric shapes found in the Holy Grail (from line drawings illustrated in this chapter) to similar shapes found in the illuminated manuscripts (after George Bain, *Celtic Art*). The appearance of the chalice inspired monks at Lindisfarne and Iona to copy the shapes and styles that appear on it.

instructing his artisans to 'manufacture a chalice containing all of the peculiar shapes found in the manuscripts—that had been chosen from thin air'? It defies belief.

And there is more anachronistic evidence: peacocks feature prolifically in the illuminated manuscripts, ostensibly because of the belief that the peacock symbolised the purity of Christ. The association apparently arose from the belief that peacock meat does not putrefy with age.⁴² St Augustine put the belief to the test by including roast peacock on the menu at a dinner in Carthage. Following the meal he ordered some of the meat to be set aside. After thirty days there was no bad smell and even after a year the meat had simply become dried out and desiccated.

If the monks copied the design of the chalice (and the Tara brooch) into the manuscripts, it seems likely that they copied the entwined bird heads from the Tara brooch (plate 21e) into their manuscripts, mistakenly believing them to be peacocks (figure 64, lower rectangle), unaware of the astronomical significance of the vulture and its association with the constellation of Orion and resurrection, the central theme of Christian teaching. This error, if it is one, supports the view that the birds were copied into the manuscripts because they [seem to] appear on the Tara brooch. But there is no need for a peacock to appear as a metaphor for the purity of Christ on the Tara brooch; that role is already fulfilled by the presence of the stag and the 144,000 (representing the number of the pure destined for Heaven). A peacock on the Tara brooch would be surplus to requirements whereas vultures convey an important astronomical function on the brooch. Again, this suggests that the ostensible peacocks were lifted from the Tara brooch, rather than that the Tara brooch vultures were copied from the manuscripts.

And in regard to unnecessary duplication, the manufacturer of the chalice would have no reason to encode information to enable the quartz crystal to spin (the swastika panels) and then again encode the same information, in a different way, in the maze-like carving on the upper foot-cone, supporting the assertion that whoever carved it did not manufacture it.

There is no scientific reason why the Ardagh Chalice cannot be the Holy Grail used by Christ at the Last Supper:

date the chalice by association with the pretenders with which it was found and likewise understandable that the date could be so far removed from the truth.

To further substantiate their argument the experts fall back on the similarities in the style of the Ardagh Chalice, the Tara Brooch and illuminated manuscripts, maintaining that the similarities demand that they must all be from the same period; insisting, for example (as we have already heard) that the insular majuscule text on the chalice is *identical* to that used in the Lindisfarne Gospels of AD 698 and therefore that the date is common to them all. And who could dispute that dozens of similarities can be found between the Chalice, the Tara Brooch and the illuminated manuscripts?

But association is a double-edged sword that begs the question of which came first, the chicken or the egg, the Chalice or the manuscripts? Did the illuminated manuscripts inspire the production of the Chalice and the Tara Brooch? Or did the Chalice and the Tara Brooch inspire the production of the manuscripts?

The insular majuscule engraving on the Chalice is *not identical* to that in the Lindisfarne Gospels as experts' claim. It is rough and crude, as though to suggest that it might have been carved with a nail.

Generally speaking (in an engineering sense) any prototype model (or manuscript) is crude and unsophisticated. Subsequent models become more refined over time until the near-perfect finished product emerges ready for the market. The insular majuscule text in the Lindisfarne Gospels is neat, refined and near perfect, suggesting that the Chalice came first and that whoever compiled the manuscript had plenty of writing practice before the manuscript was ready.

The evidence does not end there. The illuminated manuscripts contain other glaring similarities that are just *too obvious* if the official line be followed; consider the geometric shapes from the illustrations in figures 46, 47, 48, 50, 51, 60, 61 and 62. A few of these geometric line drawings are reproduced in figure 64 alongside corollary pattern designs from the books of Kells and Lindisfarne. The comparison is revealing and begs the question 'why would anyone create a manuscript containing such oddly specific geometric shapes, shapes that are all found prolifically in the Ardagh Chalice? There would be no point in picking geometric shapes

The Chalice and the Manuscripts

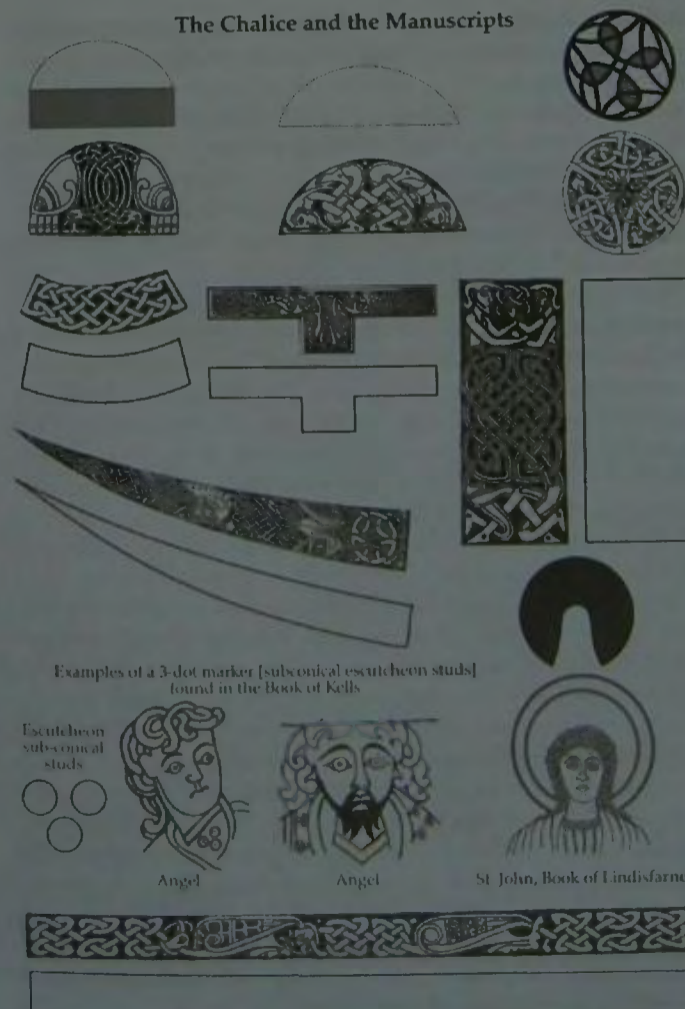

Examples of a 3-dot marker [subconical escutcheon studs] found in the Book of Kells

Escutcheon subconical studs

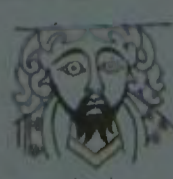
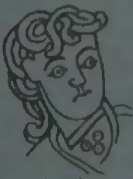
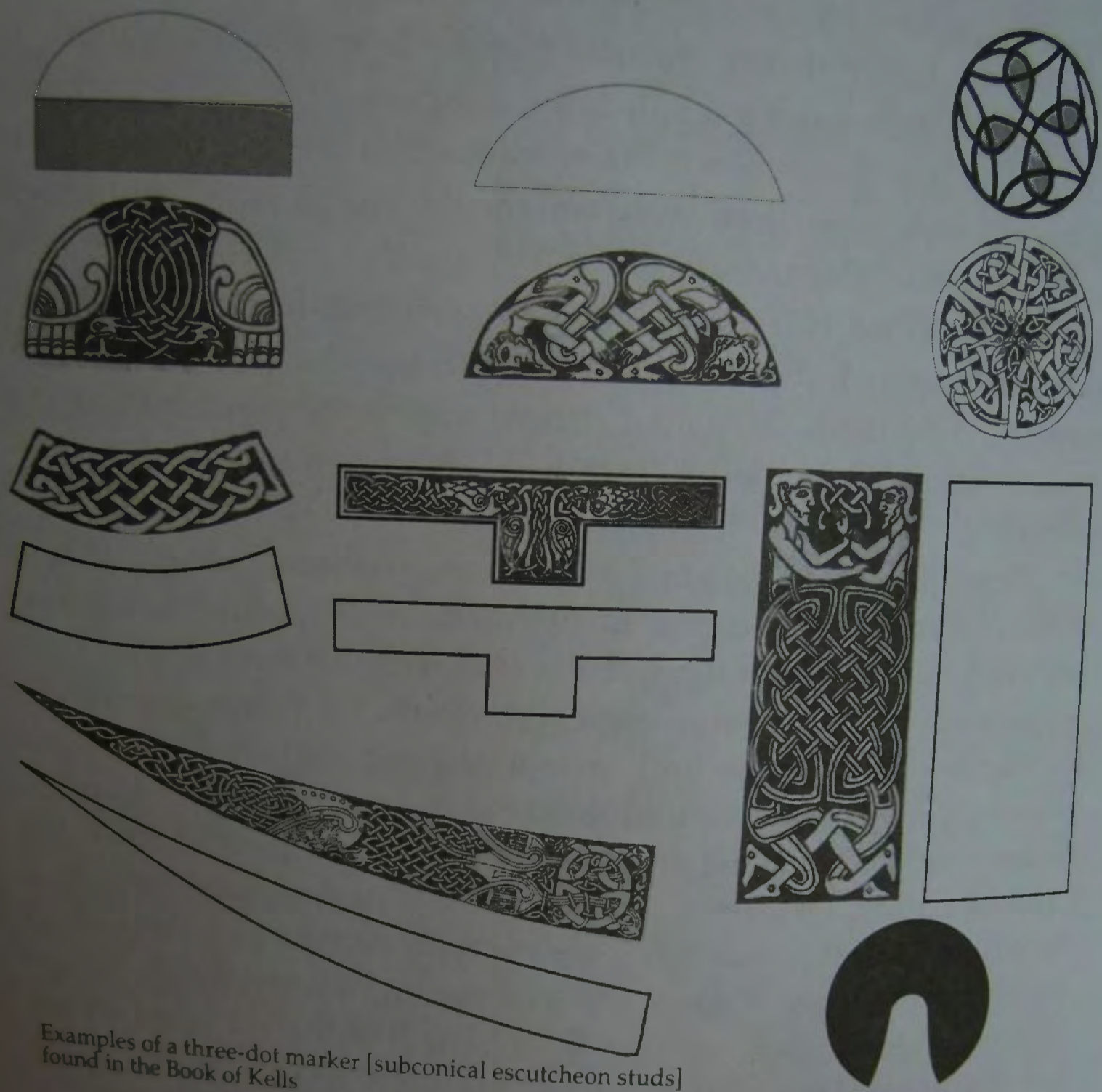

Figure 64. Comparison of geometric shapes found in the Holy Grail (from line drawings illustrated in this Chapter) to similar shapes found in the illuminated manuscripts (after George Bain, *Celtic Art*). The appearance of the Chalice inspired monks at Lindisfarne and Iona to copy the shapes and styles that appear in the Chalice.

The Chalice and the Manuscripts



Examples of a three-dot marker [subconical escutcheon studs] found in the Book of Kells

Escutcheon subconical studs

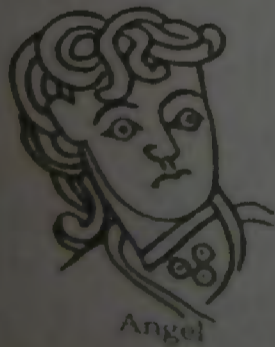

Angel



Angel



St. John, Book of Lindisfarne

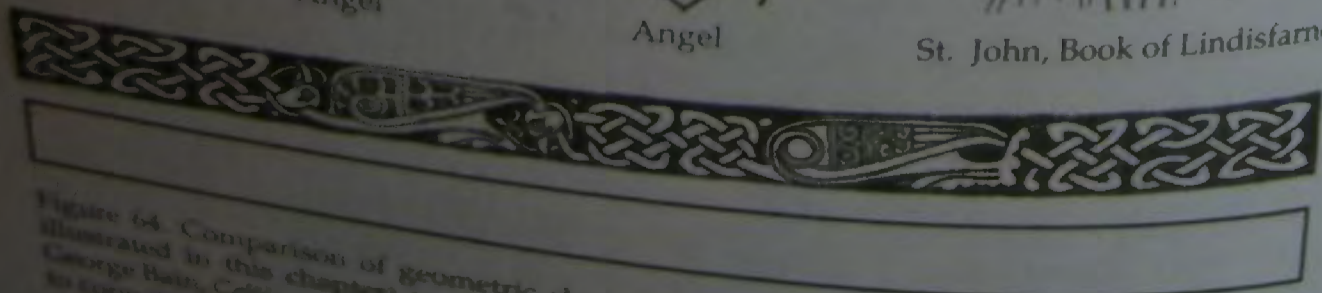

Figure 64. Comparison of geometric shapes found in the Holy Grail (from line drawings illustrated in this chapter) to similar shapes found in the illuminated manuscripts (after George Birt, *Celtic Art*). The appearance of the chalice inspired monks at Lindisfarne and Iona to copy the shapes and styles that appear on it.

- The super-science of the Sun and the higher orders of spirituality were passed on to the Celts from the King of Hochdorf as early as 550 BC.
- The champlevé style of enamelled studs in bronze mounts first appeared in around 400 BC in the Basse Yutz flagon.
- The appearance of Cernunnos the stag, as Christ, appears in the Gundestrup Cauldron c. 100 BC and on the Tara brooch.
- The style of the brooch and chalice contains similarities of the La Tène III period, which extended from 150 to 50 BC.
- There is no reason why the Ardagh Chalice and the Tara brooch could not have been designed and manufactured under instruction from the miracle-maker Jesus, just as there is no reason why the treasures of Tutankhamun could not have been designed or manufactured under instruction from the boy-king, the 'Son of God', and no reason why Mayan transformers could not have been designed and manufactured by Lord Pacal—the former Christian-Jew who reincarnated at Tiahuanaco and engraved the Holy Grail maze pattern onto the Viracocha vase.⁴³
- There is no reason why the treasures could not have been carried to England by Joseph of Arimathea.
- There is no reason why the treasures could not have been found by King Arthur, in accordance with the legends.
- There is no reason why King Arthur could not have decoded the esoteric knowledge contained in the Tara brooch, persuading him to believe that he had found the Holy Grail.
- There is no reason why Arthur, under the guidance of Merlin, could not have engraved the Grail to authenticate its provenance.
- There is no reason why the Grail and the brooch could not have been passed on to monks for safekeeping.
- There is no reason why monks could not have taken their treasures to the island monasteries—inspiring them to produce the illuminated manuscripts in the style of the Holy Grail and the Tara brooch.

If we accept the evidence of our enquiries, then we are relieved of our intellectual anxieties. We understand why we are born, why we die, why this has to be. We understand who Jesus was, why he came to Earth and the true meaning of what he left behind. We understand

out of thin air, filling them with Celtic designs and including them in the most valued manuscripts ever written. The fact that they used the shapes is evidence that they had a *reason* for using them, because they *revered* them. The reason they revered them was because the shapes are found in the most important relic of the Christian Church, the Holy Grail. It was not the other way round. Can you imagine the most senior monk in a scriptoria instructing his artisans to 'manufacture a chalice containing all of the peculiar shapes found in the manuscripts—that had been chosen from thin air?'. It defies belief.

And there is more anachronistic evidence; peacocks feature prolifically in the illuminated manuscripts, ostensibly because of the belief that the peacock symbolised the purity of Christ. The association apparently arose from the belief that peacock meat does not putrefy with age⁴². St Augustine put the belief to the test by including roast peacock on the menu at a dinner in Carthage. Following the meal he ordered some of the meat to be set aside. After 30 days there was no bad smell and even after a year the meat had simply become dried out and desiccated.

If the monks copied the design of the Chalice (and the Tara brooch) into the manuscripts it seems likely that they copied the entwined bird heads from the Tara brooch (plate 21i and j) into their manuscripts, mistakenly believing them to be peacocks (figure 64, lower rectangle), unaware of the astronomical significance of the pelican and its association with the constellation of Orion and resurrection, the central theme of Christian teaching. This error, if it is one, supports the view that the birds were copied into the manuscripts because they [seem to] appear on the Tara Brooch. But there is no need for a peacock to appear as a metaphor for the purity of Christ on the Tara brooch, that role is already fulfilled by the presence of the stag and the 144,000 (representing the number of the pure destined for Heaven). A peacock on the Tara brooch would be surplus to requirements whereas pelicans convey an important astronomical function on the Brooch. Again, this suggests that the ostensible peacocks were lifted from the Tara Brooch, rather than that the Tara brooch pelicans were copied from the manuscripts.

And, in regard to unnecessary duplication, the manufacturer of the chalice would have no reason to encode information to enable the quartz crystal to spin (the swastika panels) and then again encode the same in-

what Heaven is, what Hell is. We understand how to get to Heaven and how to avoid returning to Hell.

Conclusion

The Ardagh Chalice must be the Holy Grail referred to in the Arthurian legends. It was designed by Jesus to contain and convey the super-science of the Sun and the higher orders of spirituality:

- The 354 pieces correspond with the length of the Druidic year, last believed to have been used in AD 70, suggesting that the cup was manufactured before that time.
- The absence of one of the twelve decorative bowl-rim studs prophesied the betrayal of Jesus by Judas Iscariot and at the same time announced to the initiated the encoding of esoteric information; the 354 pieces of the chalice [together with the eleven or twelve bowl-rim studs] refer to the 365-day solar year and the 366-day solar leap year.
- The presence of two solar crosses on the bowl associates the cup with the Sun, light, God and the halo of Jesus.
- The absence of the first and last panels in the bowl-ring girdle reveal that Jesus was the first and last, the Alpha and Omega, and Venus, the evening and morning star.
- The absence of the name of Mathius in the engraved names of the Apostles around the bowl implies that whoever carved the chalice was unaware that Judas Iscariot was replaced by Mathius, suggesting that seventh-century clerics did not engrave the cup.
- The inclusion of the name of Paul suggests that whoever carved the chalice believed that Paul, not Mathius, took the place of Judas Iscariot.
- Grammatical errors in the names suggest that whoever carved the chalice was not an educated cleric, thus excluding educated seventh-century monks.
- The names of the Apostles on the chalice appear in Latin whereas the names of the Apostles in the Lindisfarne Gospels appear in Latinised Greek, suggesting that the engraving of the chalice and the writing of the illuminated manuscripts were carried out by different people.

formation, in a different way, in the maze-like carving on the upper foot-cone, supporting the assertion that whoever carved it did not manufacture it.

There is no scientific reason why the Ardagh Chalice cannot be the Holy Grail used by Christ at the Last Supper:

- The super-science of the Sun and the higher orders of spirituality were passed on to the Celts from the King of Hochdorf as early as 550 BC.
- The champlevé style of enamelled studs in bronze mounts first appeared in around 400 BC in the Basse Yutz flagon.
- The appearance of Cernunnos the stag, as Christ, appears in the Gundestrup Cauldron c. 100 BC and on the Tara brooch.
- The style of the Brooch and Chalice contain similarities of the La Tène III period, which extended from 150–50 BC.
- There is no reason why the Ardagh Chalice and the Tara Brooch could not have been designed and manufactured under instruction from the miracle-maker Jesus, just as there is no reason why the treasures of Tutankhamun could not have been designed or manufactured under instruction from the boy-king, the 'Son of God', and no reason why Maya transformers could not have been designed and manufactured by Lord Pacal—the former Christian-Jew who reincarnated at Tiahuanaco and engraved the Holy Grail maze-pattern on to the Viracocha Vase⁴³.
- There is no reason why the treasures could not have been carried to England by Joseph of Arimathea.
- There is no reason why the treasures could not have been found by King Arthur, in accordance with the legends.
- There is no reason why King Arthur could not have decoded the esoteric knowledge contained in the Tara Brooch persuading him to believe that he had found the Holy Grail.
- There is no reason why Arthur, under the guidance of Merlin, could not have engraved the Grail to authenticate its provenance.
- There is no reason why the Grail and the Brooch could not have been passed on to monks for safe-keeping.
- There is no reason why monks could not have taken their treas-

- The super-science of the Sun and the higher orders of spirituality were passed on to the Celts from the King of Hochdorf as early as 550 BC.
- The champlevé style of enamelled studs in bronze mounts first appeared in around 400 BC in the Basse Yutz flagon.
- The appearance of Cernunnos the stag, as Christ, appears in the Gundestrup Cauldron c. 100 BC and on the Tara brooch.
- The style of the brooch and chalice contains similarities of the La Tène III period, which extended from 150 to 50 BC.
- There is no reason why the Ardagh Chalice and the Tara brooch could not have been designed and manufactured under instruction from the miracle-maker Jesus, just as there is no reason why the treasures of Tutankhamun could not have been designed or manufactured under instruction from the boy-king, the 'Son of God', and no reason why Mayan transformers could not have been designed and manufactured by Lord Pacal—the former Christian-Jew who reincarnated at Tiahuanaco and engraved the Holy Grail maze pattern onto the Viracocha vase.⁴³
- There is no reason why the treasures could not have been carried to England by Joseph of Arimathea.
- There is no reason why the treasures could not have been found by King Arthur, in accordance with the legends.
- There is no reason why King Arthur could not have decoded the esoteric knowledge contained in the Tara brooch, persuading him to believe that he had found the Holy Grail.
- There is no reason why Arthur, under the guidance of Merlin, could not have engraved the Grail to authenticate its provenance.
- There is no reason why the Grail and the brooch could not have been passed on to monks for safekeeping.
- There is no reason why monks could not have taken their treasures to the island monasteries—inspiring them to produce the illuminated manuscripts in the style of the Holy Grail and the Tara brooch.

If we accept the evidence of our enquiries, then we are relieved of our intellectual anxieties. We understand why we are born, why we die, why this has to be. We understand who Jesus was, why he came to Earth and the true meaning of what he left behind. We understand

out of thin air, filling them with Celtic designs and including them in the most valued manuscripts ever written. The fact that they used the shapes is evidence that they had a *reason* for using them, because they *revered* them. The reason they revered them was because the shapes are found in the most important relic of the Christian Church, the Holy Grail. It was not the other way round. Can you imagine the most senior monk in a scriptoria instructing his artisans to 'manufacture a chalice containing all of the peculiar shapes found in the manuscripts—that had been chosen from thin air?'. It defies belief.

And there is more anachronistic evidence; peacocks feature prolifically in the illuminated manuscripts, ostensibly because of the belief that the peacock symbolised the purity of Christ. The association apparently arose from the belief that peacock meat does not putrefy with age⁴². St Augustine put the belief to the test by including roast peacock on the menu at a dinner in Carthage. Following the meal he ordered some of the meat to be set aside. After 30 days there was no bad smell and even after a year the meat had simply become dried out and desiccated.

If the monks copied the design of the Chalice (and the Tara brooch) into the manuscripts it seems likely that they copied the entwined bird heads from the Tara brooch (plate 21i and j) into their manuscripts, mistakenly believing them to be peacocks (figure 64, lower rectangle), unaware of the astronomical significance of the pelican and its association with the constellation of Orion and resurrection, the central theme of Christian teaching. This error, if it is one, supports the view that the birds were copied into the manuscripts because they [seem to] appear on the Tara Brooch. But there is no need for a peacock to appear as a metaphor for the purity of Christ on the Tara brooch, that role is already fulfilled by the presence of the stag and the 144,000 (representing the number of the pure destined for Heaven). A peacock on the Tara brooch would be surplus to requirements whereas pelicans convey an important astronomical function on the Brooch. Again, this suggests that the ostensible peacocks were lifted from the Tara Brooch, rather than that the Tara brooch pelicans were copied from the manuscripts.

And, in regard to unnecessary duplication, the manufacturer of the chalice would have no reason to encode information to enable the quartz crystal to spin (the swastika panels) and then again encode the same in-

what Heaven is, what Hell is. We understand how to get to Heaven and how to avoid returning to Hell.

Conclusion

The Ardagh Chalice must be the Holy Grail referred to in the Arthurian legends. It was designed by Jesus to contain and convey the super-science of the Sun and the higher orders of spirituality:

- The 354 pieces correspond with the length of the Druidic year, last believed to have been used in AD 70, suggesting that the cup was manufactured before that time.
- The absence of one of the twelve decorative bowl-rim studs prophesied the betrayal of Jesus by Judas Iscariot and at the same time announced to the initiated the encoding of esoteric information; the 354 pieces of the chalice [together with the eleven or twelve bowl-rim studs] refer to the 365-day solar year and the 366-day solar leap year.
- The presence of two solar crosses on the bowl associates the cup with the Sun, light, God and the halo of Jesus.
- The absence of the first and last panels in the bowl-ring girdle reveal that Jesus was the first and last, the Alpha and Omega, and Venus, the evening and morning star.
- The absence of the name of Mathius in the engraved names of the Apostles around the bowl implies that whoever carved the chalice was unaware that Judas Iscariot was replaced by Mathius, suggesting that seventh-century clerics did not engrave the cup.
- The inclusion of the name of Paul suggests that whoever carved the chalice believed that Paul, not Mathius, took the place of Judas Iscariot.
- Grammatical errors in the names suggest that whoever carved the chalice was not an educated cleric, thus excluding educated seventh-century monks.
- The names of the Apostles on the chalice appear in Latin whereas the names of the Apostles in the Lindisfarne Gospels appear in Latinised Greek, suggesting that the engraving of the chalice and the writing of the illuminated manuscripts were carried out by different people.

formation, in a different way, in the maze-like carving on the upper foot-cone, supporting the assertion that whoever carved it did not manufacture it.

There is no scientific reason why the Ardagh Chalice cannot be the Holy Grail used by Christ at the Last Supper;

- The super-science of the Sun and the higher orders of spirituality were passed on to the Celts from the King of Hochdorf as early as 550 BC.
- The champlevé style of enamelled studs in bronze mounts first appeared in around 400 BC in the Basse Yutz flagon.
- The appearance of Cernunnos the stag, as Christ, appears in the Gundestrup Cauldron c. 100 BC and on the Tara brooch.
- The style of the Brooch and Chalice contain similarities of the La Tène III period, which extended from 150–50 BC.
- There is no reason why the Ardagh Chalice and the Tara Brooch could not have been designed and manufactured under instruction from the miracle-maker Jesus, just as there is no reason why the treasures of Tutankhamun could not have been designed or manufactured under instruction from the boy-king, the 'Son of God', and no reason why Maya transformers could not have been designed and manufactured by Lord Pacal—the former Christian-Jew who reincarnated at Tiahuanaco and engraved the Holy Grail maze-pattern on to the Viracocha Vase⁴³.
- There is no reason why the treasures could not have been carried to England by Joseph of Arimathea.
- There is no reason why the treasures could not have been found by King Arthur, in accordance with the legends.
- There is no reason why King Arthur could not have decoded the esoteric knowledge contained in the Tara Brooch persuading him to believe that he had found the Holy Grail.
- There is no reason why Arthur, under the guidance of Merlin, could not have engraved the Grail to authenticate its provenance.
- There is no reason why the Grail and the Brooch could not have been passed on to monks for safe-keeping.
- There is no reason why monks could not have taken their treas-

- The rim of the bowl is softened by a gold-plated brass ring. A cross-section of the ring reveals a groove shaped like a human head. The surrounding brass ring forms a golden halo around the head. The halo [the brass ring] can only be removed by withdrawing the three tapered nails that hold the rim to the bowl, revealing the esoteric practise of releasing the divine nature of man from the body.
- The escutcheon studs are subconical in shape, enabling the holder of the cup to participate in a *virtual* Crucifixion.
- The decorative mesh-mat wire panels in the lower foot girdle explain that the body and soul are knitted together during this lifetime on Earth and that both are brought together by God.
- The decorative swastika panels convey virtual movement upon the foot-cone quartz crystal, causing it to virtually spin and thus radiate light in accordance with the legends.
- The arrangement of stones in the foot-cone can be used to calculate solar magnetic cycles.

The La Tène and Byzantine styles of the chalice show that it was manufactured in the eastern Mediterranean during the time of Christ and carried to Britain by Joseph of Arimathea following the Crucifixion. The chalice was part of a haul containing the Tara brooch that [eventually] passed into the hands of Sir Galahad, one of King Arthur's Knights of the Round Table.

In AD 453, Arthur broke the esoteric code of the Tara brooch and in so doing realised the pedigree of the chalice. To celebrate the discovery, Arthur's artisans engraved the chalice with the names of the Apostles [including St Paul] together with esoteric information supporting the provenance of the Holy Cup: two complementary dragon heads that depict the tau cross and an interlaced maze-like pattern that circumscribes the foot-cone, which conceals the esoteric number 99999 ... the number of God incarnate on Earth—but only to he who looks at the Sun and sees it spinning on its axis [only to he who understands the super-science of the Sun].

- Only King Arthur could have recognised the pedigree of the chalice after breaking the code of the Tara brooch by withdrawing the sword from the stone and becoming one of the 144,000, making him the King that was and the King that will be.

178

- The decorative mesh-mat wire panels in the lower foot girdle explain that the body and soul are knitted together during this lifetime on Earth and that both are brought together by God.
- The large spinning centre quartz crystal emulates the spinning Sun, meaning that the chalice must (intellectually) radiate light, confirming efficacy upon the Arthurian legends that show King Arthur worshipping the Grail that radiates light. Arthur must have broken the esoteric codes of the swastika panels, and to celebrate the discovery [of the holy chalice that radiates light] he must have carved the same information into the chalice in a different way, using the maze-like pattern on the upper foot-cone.
- Only Arthur, under the guidance of Merlin, could have carved the chalice with the Viracocha and King of Hochdorf maze-like pattern that circumscribes the foot-cone.
- The chalice is engraved with two conjoined dragons, the mark of the Crucifixion of Christ and the insignia of Merlin, mentor of King Arthur.
- In the Arthurian legends King Arthur is also pictured worshipping the Grail, which is flanked by two dragons, and two dragons are engraved on the chalice.
- Only Arthur, under the guidance of Merlin, would have wished to carve the chalice with two dragons.

Similarities in style between the illuminated manuscripts and the chalice arise from the fact that the chalice and the Tara brooch were passed to monks for safekeeping after Arthur died in around AD 453. In AD 698 the monks took their precious treasures to the newly established monasteries at Lindisfarne and Iona where, overawed with what they possessed, they copied the revered style of the chalice and brooch into newly created illuminated manuscripts. The appearance of the Grail and the brooch in around AD 453 inspired the production of crude inferior look-alikes. Acquisition of the relics by monks in around AD 698 led to a second wave of good-quality, sophisticated look-alikes, like the Derrynaflan hoard, that flooded the market after that time.

In around AD 802, fleeing Vikings, the monks took the chalice, the brooch and their illuminated manuscripts across the Irish Sea to the monastery at Kells. Later, again fleeing from Viking raids, the brooch

179

THE CELTIC CHRONICLES

ures to the Island monasteries—inspiring them to produce the illuminated manuscripts in the style of the Holy Grail and Tara Brooch.

If we accept the evidence of our enquiries then we are relieved of our intellectual anxieties. We understand why we are born, why we die, why this has to be. We understand who Jesus was, why he came to Earth and the true meaning of what he left behind. We understand what Heaven is, what Hell is. We understand how to get to Heaven and how to avoid returning to Hell.

Conclusion

The Ardagh Chalice must be the Holy Grail referred to in the Arthurian legends. It was designed by Jesus to contain and convey the super science of the Sun and the higher orders of spirituality:

- The 354 pieces correspond with the length of the Druidic year, last believed to have been used in AD 70, suggesting that the cup was manufactured before that time.
- The absence of one of the 12 decorative bowl-rim studs prophesied the future betrayal of Jesus by Judas Iscariot and at the same time announced to the initiated the encoding of esoteric information; the 354 pieces of the Chalice [together with the 11 or 12 bowl-rim studs] refer to the 365-day solar year and 366-day solar leap year.
- The presence of two solar crosses on the bowl associate the cup with the Sun, light, God and the halo of Jesus.
- The absence of the first and last panels in the bowl-ring girdle reveal that Jesus was the first and last, the Alpha and Omega, and Venus, the bright and morning star.
- The absence of the name of Mathius in the engraved names of the Apostles around the bowl infers that whoever carved the chalice was unaware that Judas Iscariot was replaced by Mathius, suggesting that seventh-century clerics did not engrave the cup.
- The inclusion of the name of Paul suggests that whoever carved the chalice believed that Paul, not Mathius, took the place of Judas Iscariot.

178

THE HOLY GRAIL

- Grammatical errors in the names suggest that whoever carved the chalice was not an educated cleric thus excluding educated seventh century monks.
- The names of the Apostles on the chalice appear in Latin whereas the names of the Apostles in the Lindisfarne Gospels appear in Latinised-Greek, suggesting that the engraving of the chalice and the writing of the illuminated manuscripts was carried out by different people.
- The rim of the bowl is softened by a gold-plated brass ring. A cross-section of the ring reveals a groove shaped like a human head. The surrounding brass ring forms a golden halo around the head. The halo [the brass ring] can only be removed by withdrawing the three tapered nails that hold the rim to the bowl; revealing the esoteric practice of releasing the divine nature of man from the body.
- The escutcheon studs are subconical in shape enabling the holder of the cup to participate in a *virtual* Crucifixion.
- The decorative mesh-mat wire panels in the lower foot-girdle explain that the body and soul are knitted together during this lifetime on Earth and that both are brought together by God.
- The decorative swastika panels convey virtual movement upon the foot-cone quartz crystal causing it to virtually spin and thus radiate light in accordance with the legends.
- The arrangement of stones in the foot-cone can be used to calculate solar magnetic cycles.

The La Tène and Byzantine style of the chalice show that it was manufactured in the eastern Mediterranean during the time of Christ and carried to Britain by Joseph of Arimathea following the Crucifixion. The Chalice was part of a haul containing the Tara Brooch that [eventually] passed into the hands of Sir Galahad, one of King Arthur's Knights of the Round Table.

In AD 453, Arthur broke the esoteric code of the Tara Brooch and in so doing realised the pedigree of the Chalice. To celebrate the discovery, Arthur's artisans engraved the Chalice with the names of the Apostles [including St Paul] together with esoteric information supporting the

and chalice became separated. They were hidden from hostile incursions by monks and eventually lost, before their rediscovery in 1850 and 1868.

Today the Holy Grail is kept in the National Museum of Ireland in Dublin, together with the Tara brooch and the Rinnagan Crucifixion plaque.

provenance of the Holy cup; two complementary dragonheads that depict the Tau Cross and an interlaced maze-like pattern that circumscribes the foot-cone which conceals the esoteric number 99999... the number of God incarnate on Earth—but only to he who looks at the Sun and sees it spinning on its axis [only to he who understands the super-science of the Sun].

- Only King Arthur could have recognised the pedigree of the chalice after breaking the code of the Tara Brooch by withdrawing the sword from the stone and becoming one of the 144,000, making him the King that was and the King that will be.
- The decorative mesh-mat wire panels in the Lower foot-girdle explain that the body and soul are knitted together during this lifetime on Earth and that both are brought together by God.
- The large spinning centre quartz crystal emulates the spinning Sun, meaning that the chalice must (intellectually) radiate light, confirming efficacy upon the Arthurian legends that show King Arthur worshipping the Grail that radiates light. Arthur must have broken the esoteric codes of the swastika panels and to celebrate the discovery [of the holy chalice that radiates light] he must have carved the same information into the chalice in a different way, using the maze-like pattern on the upper foot-cone.
- Only Arthur, under the guidance of Merlin, could have carved the chalice with the Viracocha and King of Hochdorf maze-like pattern that circumscribes the foot-cone.
- The chalice is engraved with two conjoined dragons, the mark of the Crucifixion of Christ and the insignia of Merlin, mentor of King Arthur.
- In the Arthurian legends King Arthur is also pictured worshipping the Grail which is flanked by two dragons, and two dragons are engraved on the chalice.
- Only Arthur, under the guidance of Merlin, would have wished to carve the chalice with two dragons.

Similarities in style between the illuminated manuscripts and the Chalice arise from the fact that the Chalice and the Tara Brooch were passed to monks for safe-keeping after Arthur died in around AD 453. In AD 698

The Secret of the Grail

The First Picture of God

The most remarkable feature of the Grail, revealed by our analysis, must be its association with light (electromagnetic energy) which in turn associates it directly with God, as no other known artefact does. He who beholds the light in the Grail is the one who understands the secrets of the maze-like engraving around the foot-cone and the reverse swastikas in the mesh-mat panels, knowledge of which enables the construction of an intellectual mechanistic model that sets the quartz crystal in motion. As the crystal virtually spins, the 666 of the body is converted into the 999 of the soul.

The Grail, with its maze-like pattern and reverse swastikas in common with the Hallstatt scabbard, the Viracocha tunic maze-like pattern, and the spiral arrangement on the Rinnagan Crucifixion plaque all break down the spiritual conversion process into definitive steps beginning with 666 and ending with 999, explaining that the purpose of physical life is to purify the soul within.

The same message was left by Lord Pacal; plate 4 shows Lord Pacal in his emanation as 'the beast', the stag, when the Mural of Bonampak transparencies are juxtaposed at 66.6°. Figure A27 shows Lord Pacal as the feathered snake, again as the beast on Earth, but only when the transparencies are set to 66.6°.

And the mosaic mask has more to reveal: when the transparencies are set at 99.9° (plate 24), a complex series of pictures (hitherto

the monks took their precious treasures to the newly established monasteries at Lindisfarne and Iona where, overawed with what they possessed, they copied the revered style of the Chalice and Brooch into newly created illuminated manuscripts. The appearance of the Grail and the Brooch in around AD 453 inspired the production of crude inferior look-alikes. Acquisition of the relics by monks in around AD 698 led to a second wave of good quality sophisticated look-alikes, like the Derrynaflan Hoard, that flooded the market after that time.

In around AD 802, fleeing Vikings, the monks took the Grail, the Brooch and their illuminated manuscripts across the Irish Sea to the monastery at Kells. Later, again fleeing from Viking raids, the Brooch and Grail became separated. They were hidden from hostile incursions by monks and eventually lost, before their rediscovery in 1850 and 1868.

Today the Holy Grail is kept in the National Museum of Ireland in Dublin, Ireland, together with the Tara Brooch and the Rinnagan Crucifixion Plaque.

Notes:

- 42 Isidori Hispalensis Episcopi Etymologiarum sive Originum, Ed. W. M. Lindsay, 2 vols., Oxford, 1911, 'Vol. 2 lib XII vii. 48.
- 43 These Supergods knew of their impending death, as a passage from the Popol Vuh implies: 'They were endowed with intelligence; they saw and instantly they could see far, they succeeded in seeing, they succeeded in knowing all that there is in the world. When they looked, instantly they saw all around them, and they contemplated the arch of the heavens and the round face of the Earth. The things hidden (in the distance) they saw all, without first having to move; at once they saw the world... Great was their wisdom' (*The Popol Vuh*, Delia Goetz and Sylvanus G. Morley, University of Oklahoma Press, 1947).

and chalice became separated. They were hidden from hostile incursions by monks and eventually lost, before their rediscovery in 1850 and 1868.

Today the Holy Grail is kept in the National Museum of Ireland in Dublin, together with the Tara brooch and the Rinnagan Crucifixion plaque.

CHAPTER SIX

The Secret of the Grail

The First Picture of God

The most remarkable feature of the Grail, revealed by our analysis, must be its association with light (electromagnetic energy) which in turn associates it directly with God, as no other known artefact does. He who beholds the light in the Grail is the one who understands the secrets of the maze-like engraving around the foot-cone and the reverse swastikas in the mesh-mat panels, knowledge of which enables the construction of an intellectual mechanistic model that sets the quartz crystal in motion. As the crystal virtually spins, the 666 of the body is converted into the 999 of the soul.

The Grail, with its maze-like pattern and reverse swastikas in common with the Hallstatt scabbard, the Viracocha tunic maze-like pattern, and the spiral arrangement on the Rinnagan Crucifixion plaque all break down the spiritual conversion process into definitive steps beginning with 666 and ending with 999, explaining that the purpose of physical life is to purify the soul within.

The same message was left by Lord Pacal; plate 4 shows Lord Pacal in his emanation as 'the beast', the stag, when the Mural of Bonampak transparencies are juxtaposed at 66.6°. Figure A27 shows Lord Pacal as the feathered snake, again as the beast on Earth, but only when the transparencies are set to 66.6°.

And the mosaic mask has more to reveal: when the transparencies are set at 99.9° (plate 24), a complex series of pictures (hitherto

CHAPTER SIX

The Secret of the Grail

The First picture of God

The most remarkable feature of the Grail, revealed by our analysis, must be its association with light (electromagnetic energy) which in turn associates it directly with God, as no other known artefact does. He who beholds the light in the Grail is the one who understands the secrets of the maze-like engraving around the foot-cone and the reverse-swastikas in the mesh-mat panels; knowledge of which enables the construction of an intellectual mechanistic model that sets the quartz crystal into motion. As the crystal virtually spins the 666 of the body is converted into 999 of the soul.

The Grail—with its maze-like pattern and reverse swastikas—in common with the Hallstatt scabbard—with its maze-like pattern and reverse swastikas—the Viracocha tunic maze-like pattern—and the spiral arrangement on the Rinnagan Crucifixion plaque all break down the spiritual conversion process into definitive steps beginning with 666 and ending with 999; explaining that the purpose of physical life is to purify the soul within.

The same message was left by Lord Pacal; plate 4 showed Lord Pacal in his emanation as 'the beast', the stag, when the Mural of Bonampak transparencies are juxtaposed at 66.6°. Figure A27 showed Lord Pacal as the feathered-snake, again as the beast on Earth, but only when the trans-

parencies are set to 66.6°.

And the Mosaic Mask has more to reveal; when the transparencies are set at 99.9° (plate 24) a complex series of pictures (hitherto unpublished) emerges, showing the head and face of a man—the small man with the hat from Peru, encountered earlier.

Figure 65 analyses the geometric significance of a series of shapes located either side of the small man's hat. The angular relationship between the shapes is given by the schematics (a) – (c); the arc represents the disc of the Sun. An oblique line next to the Sun is set at 23.5° to the horizontal (the horizon), meaning that the line must represent the Earth which is tilted at 23.5° on its axis (figure 65b). When the Earth-lines are levelled they each intersect with a corresponding tiny circle positioned either side of the Sun discs. Figure 65d; demonstrates that the two tiny circles must represent the planet Venus because the line of the brim of the hat intersects the circles at 177°, the angle by which Venus is tilted on its axis. The man with the hat is thus positioned between the rising morning star and the setting evening star, meaning that the man with the hat must be the Sun, God.

The small man with the hat shown in plate 24a (box-framed) was found in the tomb of Viracocha Pachacamac, at Sipan in Peru. Figure 66 shows a crab covering the face of the small man in the composite sketch. Markings on the crab correlate with markings on the 60-cm- (two-foot-) high golden anthropomorphic crab-man found in the tomb of Viracocha (plate 5d) which is also sketched in figure 66e. The face of the Bat God covers the face of the crab.

The ancient belief that the soul leaves the body through a hole at the top of the head was illustrated earlier by the Chinese jade burial suit of Prince Liu Sheng (plate 21g) and Plate 24 shows the soul of the small man leaving from a hole in his head. Indeed the picture becomes more complex—an eagle catches the soul between its open beak as it soars through the air.

The circular soul doubles as a halo for another character immediately below the beak [the triangular shaped face has been coloured red to help identification]. Here stands a Christ-like figure, as though prostrate on the cross, with ankles pinned together [indicated by the tiny red circle just above the feet] carrying the compasses of the freemason. The

unpublished) emerges, showing the head and face of a man—the small man with the hat from Peru encountered earlier.

Figure 65 analyses the geometric significance of a series of shapes located either side of the small man's hat. The angular relationship between the shapes is given by the schematics a-c; the arc represents the disc of the Sun. An oblique line next to the Sun is set at 23.5° to the horizontal (the horizon), meaning that the line must represent the Earth which is tilted at 23.5° on its axis (figure 65b). When the Earth-lines are levelled they each intersect with a corresponding tiny circle positioned either side of the Sun discs. Figure 65d demonstrates that the two tiny circles must represent the planet Venus because the line of the brim of the hat intersects the circles at 177°, the angle by which Venus is tilted on its axis. The man with the hat is thus positioned between the rising morning star and the setting evening star, meaning that the man with the hat must be the Sun, God.

The small man with the hat shown in plate 24a (box framed) was found in the tomb of Viracocha Pachacamac, at Sipan in Peru. Figure 66 shows a crab covering the face of the small man in the composite sketch. Markings on the crab correlate with markings on the 60-cm- (two-foot-) high golden anthropomorphic crab-man found in the tomb of Viracocha (plate 5d), which is also sketched in figure 66e. The face of the bat god covers the face of the crab.

The ancient belief that the soul leaves the body through a hole at the top of the head was illustrated earlier by the Chinese jade burial suit of Prince Liu Sheng (plate 21g), and plate 24 shows the soul of the small man leaving a hole in his head. Indeed the picture becomes more complex—an eagle catches the soul in its open beak as it soars through the air.

The circular soul doubles as a halo for another character immediately below the beak [the triangular-shaped face has been coloured red to help identification]. Here stands a Christlike figure, as though prostrate on the cross, with ankles pinned together [indicated by the tiny red circle just above the feet] carrying the compasses of the Freemason. The compasses are composed of the same lines previously described as Earth-lines in the figure 65 analysis. They were set at 23.5° to the horizontal and by default at 66.5° (90° - 23.5°) to the vertical. The Christlike figure thus carries each leg of the compasses at 66° to himself. Earlier,

The Mosaic Mask of Palenque
The First Picture of God (II)

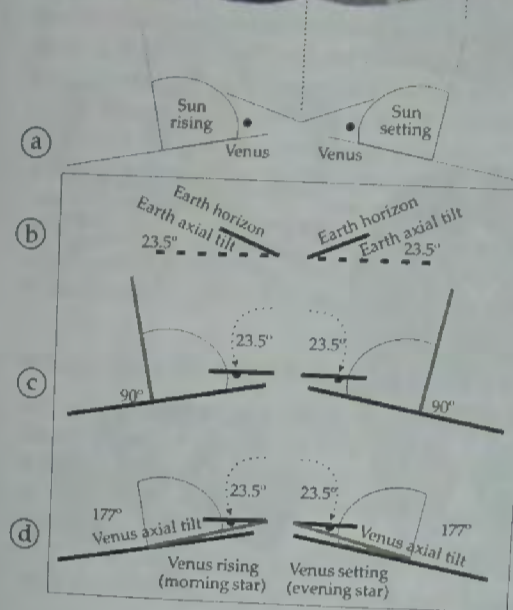

Figure 65. Composite scene from the mosaic mask of Palenque (see also plate 24). The small man carries a geometric line arrangement either side of his hat (highlighted in bold white on the composite picture). The line arrangement is reproduced in the schematics below. (a) Line arrangement as it appears on the composite. The arc represents the disc of the Sun. Venus is shown either side of the Sun in its various manifestations as the morning star and the evening star. (b) The line above Venus is tilted at 23.5° to the horizontal, indicating that the line represents Earth. (c) Adjusting the Earth-line by 23.5°, Venus rises and falls above and below the Earth's horizon. The line shown at 90°, is a reference line; when the line is moved counterclockwise by 90°, it aligns with the 'Venus-line'. (d) When the Venus-line is now rotated clockwise by 177° [the angle by which Venus is tilted on its axis], it touches the Earth horizon line. This elaborate explanation confirms that the tiny circles either side of the Sun discs represent Venus, meaning that the man between the discs must be the Sun, God. This must therefore be the first picture of God.

The Mosaic Mask of Palenque
The First Picture of God (II)

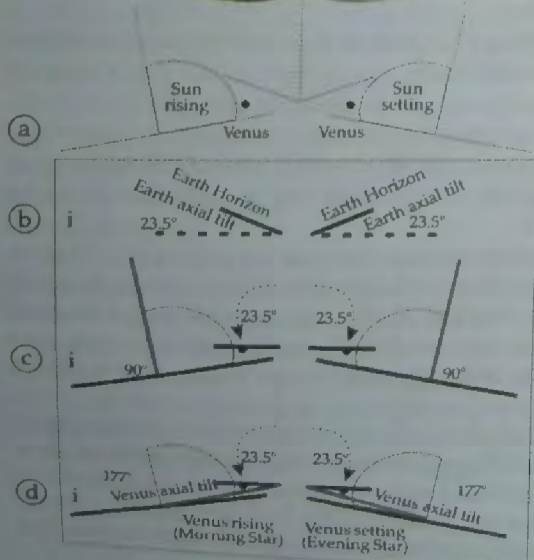

Figure 65. Composite scene from the Mosaic Mask of Palenque (see also plate 24). The small man carries a geometric line arrangement either side of his hat (highlighted in bold white on the composite picture). The line arrangement is reproduced in the schematics below: (a) line arrangement as it appears on the composite. The arc represents the disc of the Sun. Venus is shown either side of the Sun in its various manifestations as the morning star and the evening star. (b) The line above Venus is tilted at 23.5° to the horizontal, indicating that the line represents Earth. (c) Adjusting the Earth-line by 23.5°, Venus rises and falls above and below the Earth's horizon. The line shown at 90° is a reference line; when the line is moved counterclockwise by 90° it aligns with the 'Venus-line'. (d) When the Venus-line is now rotated clockwise by 177° [the angle by which Venus is tilted on its axis] it touches the Earth horizon line. This elaborate explanation confirms that the tiny circles either side of the Sun discs represent Venus, meaning that the man between the discs must be the Sun, God. This must therefore be the first picture of God.

The Mosaic Mask of Palenque
The Man who was Venus

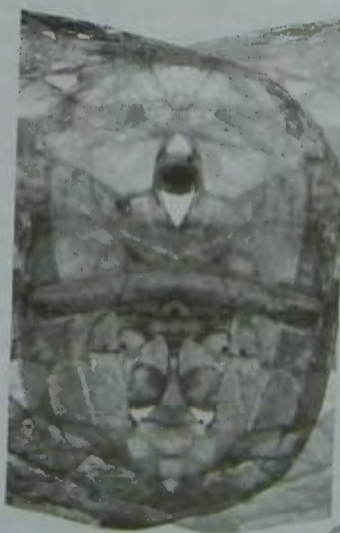
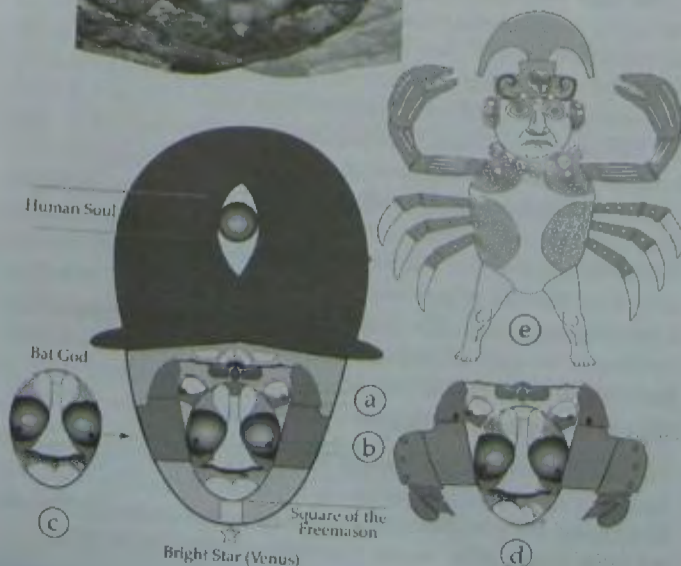

Figure 66. (a) Venus setting against the disc (eye ball) of the Sun. (b) Venus rising against the disc of the Sun. (c) Face of the Bat God. (d) Crab—the man's eyes stare at the crab's eyes located below and either side of his own. (e) Sketch of the 60-cm- (2-foot-) high golden anthropomorphic model of the crabman found in the tomb of Viracocha Pachacamac at Sipan, Peru (see also plate 5d). The three circles on the crab's thighs also appear in (d). As mentioned earlier, the crab lives in the 'foam of the sea' and is therefore used as a metaphor to describe the perfect human being, Viracocha, in the language of the Quechua of Bolivia [ancient Peru].



unpublished) emerges, showing the head and face of a man—the small man with the hat from Peru encountered earlier.

Figure 65 analyses the geometric significance of a series of shapes located either side of the small man's hat. The angular relationship between the shapes is given by the schematics a-c; the arc represents the disc of the Sun. An oblique line next to the Sun is set at 23.5° to the horizontal (the horizon), meaning that the line must represent the Earth which is tilted at 23.5° on its axis (figure 65b). When the Earth-lines are levelled they each intersect with a corresponding tiny circle positioned either side of the Sun discs. Figure 65d demonstrates that the two tiny circles must represent the planet Venus because the line of the brim of the hat intersects the circles at 177° , the angle by which Venus is tilted on its axis. The man with the hat is thus positioned between the rising morning star and the setting evening star, meaning that the man with the hat must be the Sun, God.

The small man with the hat shown in plate 24a (box framed) was found in the tomb of Viracocha Pachacamac, at Sipan in Peru. Figure 66 shows a crab covering the face of the small man in the composite sketch. Markings on the crab correlate with markings on the 60-cm- (two-foot-) high golden anthropomorphic crab-man found in the tomb of Viracocha (plate 5d), which is also sketched in figure 66e. The face of the bat god covers the face of the crab.

The ancient belief that the soul leaves the body through a hole at the top of the head was illustrated earlier by the Chinese jade burial suit of Prince Liu Sheng (plate 21g), and plate 24 shows the soul of the small man leaving a hole in his head. Indeed the picture becomes more complex—an eagle catches the soul in its open beak as it soars through the air.

The circular soul doubles as a halo for another character immediately below the beak [the triangular-shaped face has been coloured red to help identification]. Here stands a Christlike figure, as though prostrate on the cross, with ankles pinned together [indicated by the tiny red circle just above the feet] carrying the compasses of the Freemason. The compasses are composed of the same lines previously described as Earth-lines in the figure 65 analysis. They were set at 23.5° to the horizontal and by default at 66.5° ($90^\circ - 23.5^\circ$) to the vertical. The Christlike figure thus carries each leg of the compasses at 66° to himself. Earlier,

The Mosaic Mask of Palenque
The First Picture of God (II)

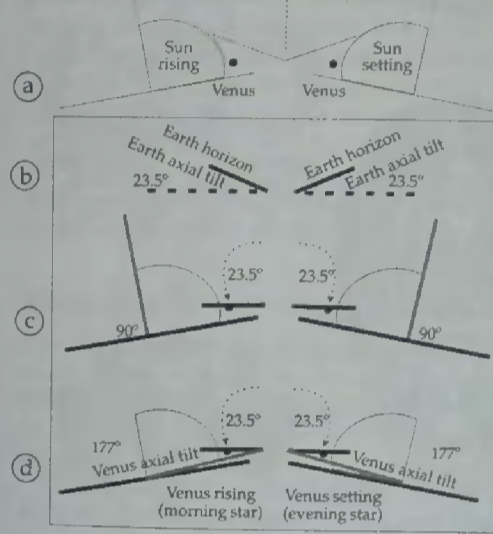

Figure 65. Composite scene from the mosaic mask of Palenque (see also plate 24). The small man carries a geometric line arrangement either side of his hat (highlighted in bold white on the composite picture). The line arrangement is reproduced in the schematics below: (a) Line arrangement as it appears on the composite. The arc represents the disc of the Sun. Venus is shown either side of the Sun in its various manifestations as the morning star and the evening star. (b) The line above Venus is tilted at 23.5° to the horizontal, indicating that the line represents Earth. (c) Adjusting the Earth-line by 23.5° , Venus rises and falls above and below the Earth's horizon. The line shown at 90° , is a reference line; when the line is moved counter-clockwise by 90° , it aligns with the 'Venus-line'. (d) When the Venus-line is now rotated clockwise by 177° [the angle by which Venus is tilted on its axis], it touches the Earth horizon line. This elaborate explanation confirms that the tiny circles either side of the Sun discs represent Venus, meaning that the man between the discs must be the Sun, God. This must therefore be the first picture of God.

The Mosaic Mask of Palenque
The First Picture of God (II)

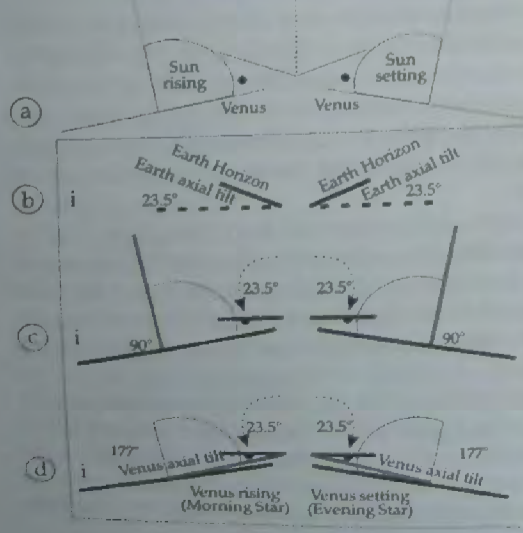

Figure 65. Composite scene from the Mosaic Mask of Palenque (see also plate 24). The small man carries a geometric line arrangement either side of his hat (highlighted in bold white on the composite picture). The line arrangement is reproduced in the schematics below: (a) line arrangement as it appears on the composite. The arc represents the disc of the Sun. Venus is shown either side of the Sun in its various manifestations as the morning star and the evening star. (b) The line above Venus is tilted at 23.5° to the horizontal, indicating that the line represents Earth. (c) Adjusting the Earth-line by 23.5° , Venus rises and falls above and below the Earth's horizon. The line shown at 90° is a reference line; when the line is moved counterclockwise by 90° it aligns with the 'Venus-line'. (d) When the Venus-line is now rotated clockwise by 177° [the angle by which Venus is tilted on its axis] it touches the Earth horizon line. This elaborate explanation confirms that the tiny circles either side of the Sun discs represent Venus, meaning that the man between the discs must be the Sun, God. This must therefore be the first picture of God.

The Mosaic Mask of Palenque
The Man who was Venus

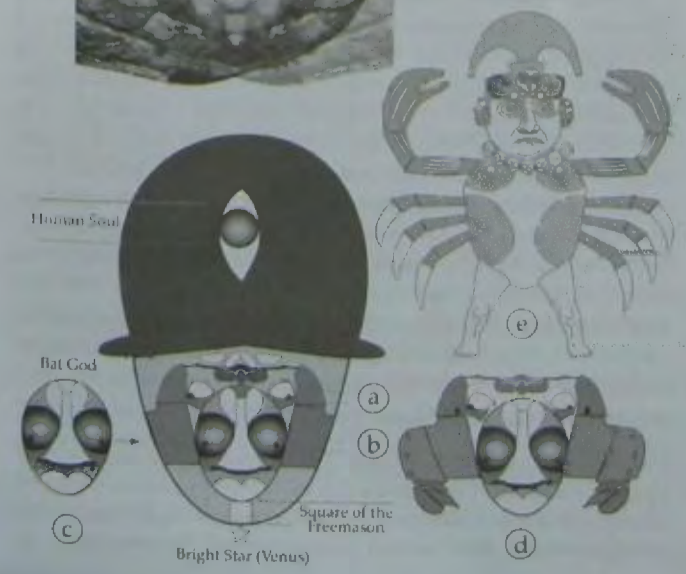

Figure 66. (a) Venus setting against the disc [eye ball] of the Sun. (b) Venus rising against the disc of the Sun. (c) Face of the Bat God. (d) Crab—the man's eyes stare at the crab's eyes located below and either side of his own. (e) Sketch of the 60-cm- (2-foot-) high golden anthropomorphic model of the crab-man found in the tomb of Viracocha Pachacamac at Sipan, Peru (see also plate 5d). The three circles on the crab's thighs also appear in (d). As mentioned earlier, the crab lives in the 'foam of the sea' and is therefore used as a metaphor to describe the perfect human being, Viracocha, in the language of the Quechua of Bolivia [ancient Peru].

The Mosaic Mask of Palenque The First Picture of God (II)

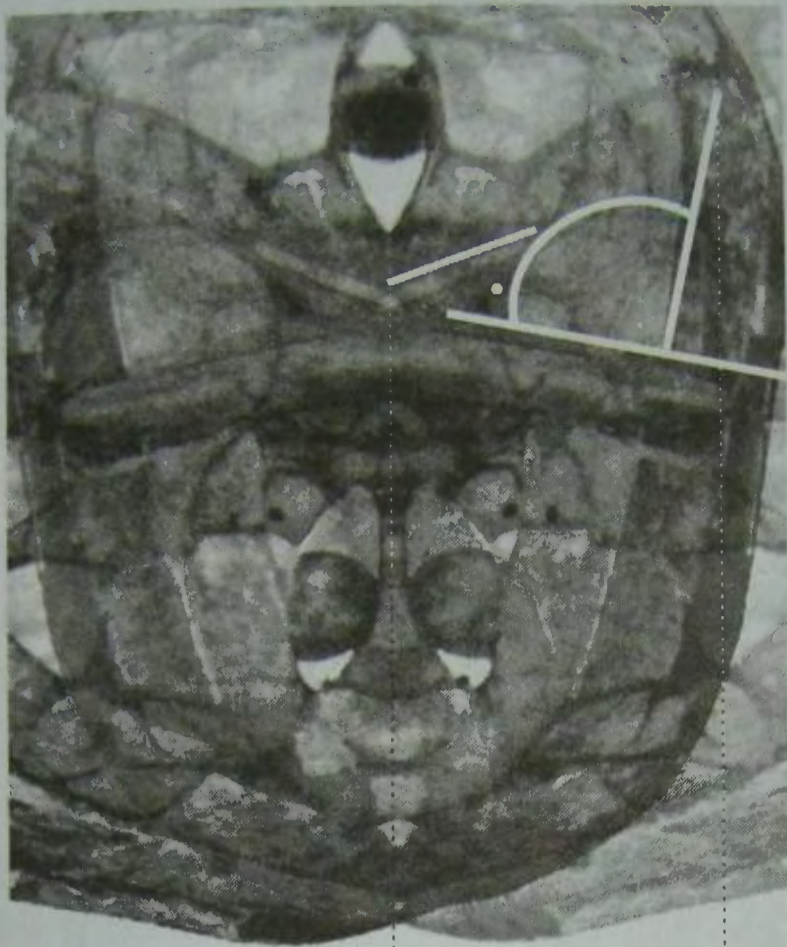
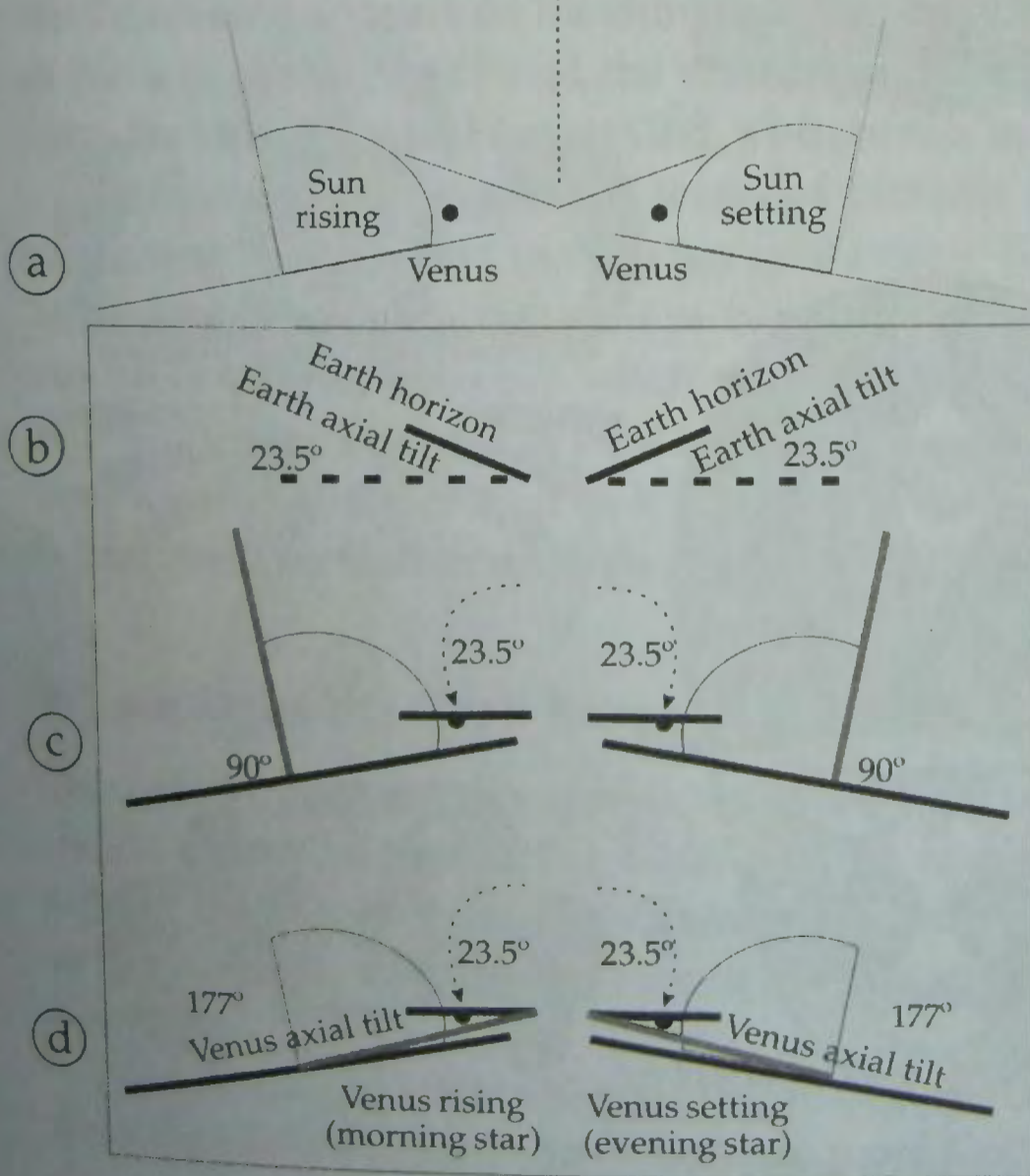

Figure 65. Composite scene from the mosaic mask of Palenque (see also plate 24). The small man carries a geometric line arrangement either side of his hat (highlighted in bold white on the composite picture). The line arrangement is reproduced in the schematics below. (a) Line arrangement as it appears on the composite. The arc represents the disc of the Sun. Venus is shown either side of the Sun in its various manifestations as the morning star and the evening star. (b) The line above Venus is tilted at 23.5° to the horizontal, indicating that the line represents Earth. (c) Adjusting the Earth-line by 23.5° , Venus rises and falls above and below the Earth's horizon. The line shown at 90° , is a reference line; when the line is moved counter-clockwise by 90° , it aligns with the 'Venus-line'. (d) When the Venus-line is now rotated clockwise by 177° [the angle by which Venus is tilted on its axis], it touches the Earth horizon line. This elaborate explanation confirms that the tiny circles either side of the Sun discs represent Venus, meaning that the man between the discs must be the Sun, God. This must therefore be the first picture of God.



The Mosaic Mask of Fafnir
The Man who was Stone



Figure 40. The Mosaic Mask of Fafnir, the dragon who guarded the entrance to the tomb of the slain King Sigurd. The mask was made of the same material as the mask of the dragon who guarded the entrance to the tomb of the slain King Sigurd. The mask was made of the same material as the mask of the dragon who guarded the entrance to the tomb of the slain King Sigurd.



The Mosaic Mask of Palenque The First Picture of God (II)



Figure 65. Composite scene from the Mosaic Mask of Palenque (see also plate 24); The small man carries a geometric line arrangement either side of his hat (highlighted in bold white on the composite picture). The line arrangement is reproduced in the schematics below; (a) line arrangement as it appears on the composite. The arc represents the disc of the Sun. Venus is shown either side of the Sun in its various manifestations as the morning star and the evening star. (bi) The line above Venus is tilted at 23.5° to the horizontal, indicating that the line represents Earth. (ci) Adjusting the Earth-line by 23.5° Venus rises and falls above and below the Earth's horizon. The line shown at 90° is a reference line; when the line is moved counterclockwise by 90° it aligns with the 'Venus-line'. (di) When the Venus-line is now rotated clockwise by 177° [the angle by which Venus is tilted on its axis] it touches the Earth horizon line. This elaborate explanation confirms that the tiny circles either side of the Sun discs represent Venus, meaning that the man between the discs must be the Sun, God. This must therefore be the first picture of God.

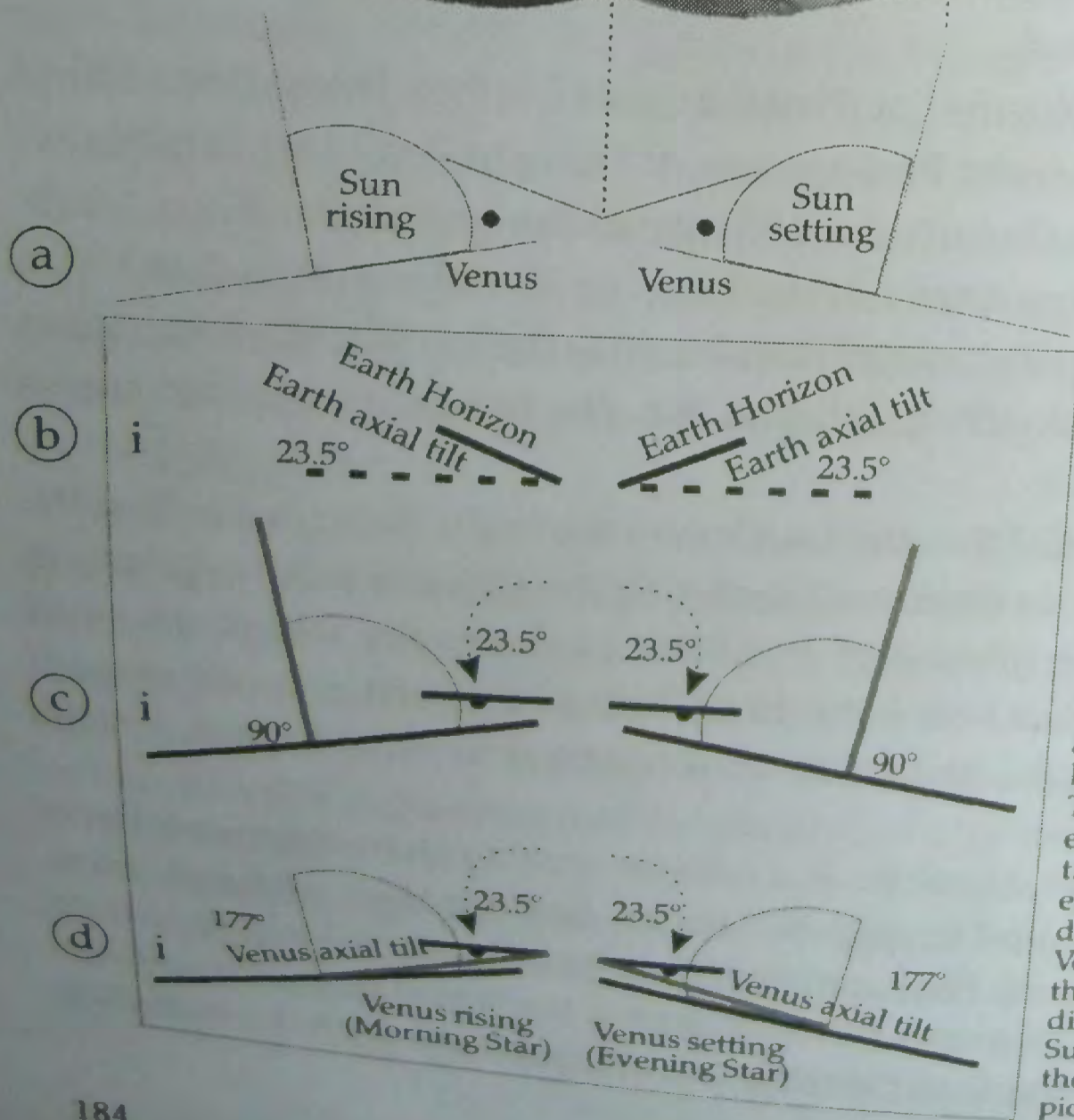



Figure 66. (a) Venus setting against the disc [eyeball] of the Sun. (b) Venus rising against the disc of the Sun. (c) Face of the bat god. (d) Crab—the man's eyes stare at the crab's eyes located below and either side of his own. (e) Sketch of the two-foot- (60-cm-) high golden anthropomorphic model of the crab-man found in the tomb of Viracocha Pachacamac at Sipan, Peru (see also plate 5d). The three circles on the crab's thighs also appear in (d). As mentioned earlier, the crab lives in the 'foam of the sea' and is therefore used as a metaphor to describe the perfect human being, Viracocha, in the language of the Quechua of Bolivia [ancient Peru].

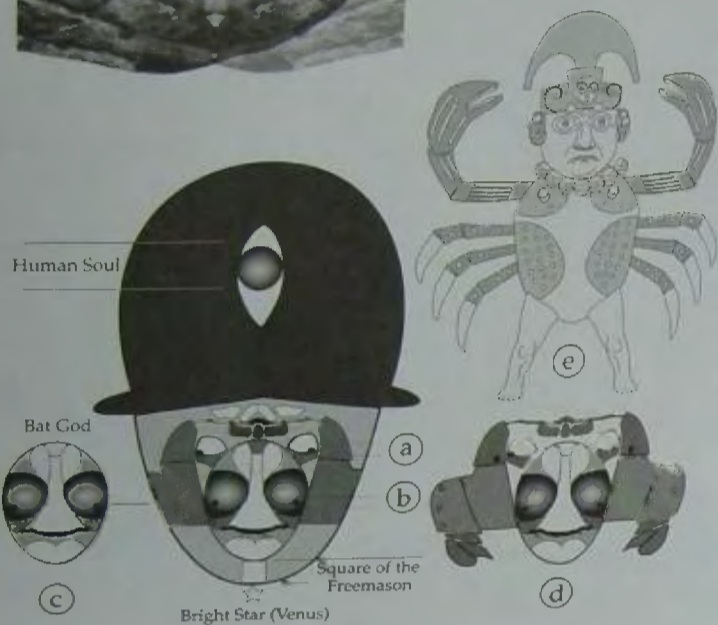

figure 42 showed Christ carrying the compasses of the Freemason set at 66° and showed the compasses formed by the spindles on the spinning wheel to be set in the same way.

Figure A26 shows a 'spider chamber' found in the tomb of Viracocha. The spider spins a silver thread which, like the analysis undertaken in figure 42, associates Viracocha with the mythical silver thread, the cable-tow that tethers the soul to the body during out-of-body sojourns. This explains why spiritual types (priests, clerics, orthodox Jews, etc.) all wear a hat when praying: to prevent the soul from leaving through the ostensible hole (spiritual gateway) we are told is located in the top of the head—should they become too close to God through prayer—before their time is up. The small man wears a hat to demonstrate the same principles.

The eagle with outstretched wings in plate 24 not only carries away the soul of the small man but also carries away the Christlike figure and his compasses (in its claws). At the same time the small man acquires wings, his spirit soars and he flies away with the eagle. The square of the Freemason appears on his chin together with a five-pointed star. All of this tells us that Lord Pacal, the Viracochas and Jesus were each, in his turn, the virtuous who became God, a bright star in the Heavens.

Moreover, this remarkable series of pictures explicitly acknowledges that 'God created man in his own image' (Genesis I, 27). Plate 24 therefore shows the first ever picture of God and explains that man can become God, but only when man transforms the 66.6° into the 99.9° —the same message as the Grail. It seems, also, that the small man represents a picture of God on Earth, a Supergod. That this is the case is confirmed by further analysis provided by figures 65 and 66.

Whom Does the Grail Serve?

The answer to Perceval's question of 'Whom does the Grail serve?' should by now be clear. The Grail was the cup left behind by Jesus following his life on Earth. It is a tangible representation of everything he taught about the super-science of the Sun and the higher orders of spirituality.

The Theory of Divine Reconciliation (figure A19) explicitly recognises that God wishes to grow because more God is 'more love' and

The Mosaic Mask of Palenque
The First Picture of God (II)

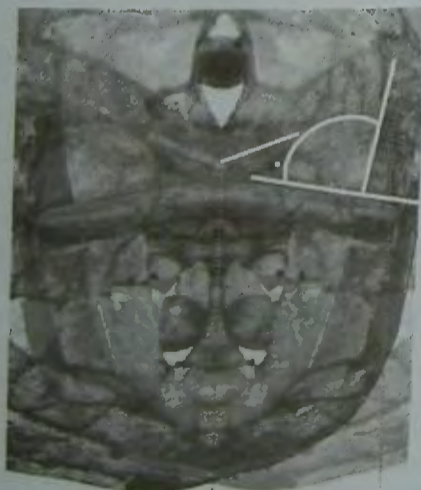
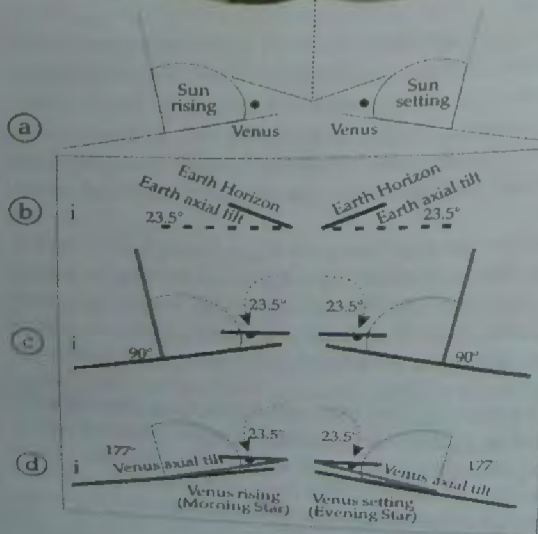

Figure 65. Composite scene from the Mosaic Mask of Palenque (see also plate 24); The small man carries a geometric line arrangement either side of his hat (highlighted in bold white on the composite picture). The line arrangement is reproduced below; (a) line arrangement as it appears on the composite. The arc represents the disc of the Sun. Venus is shown either side of the Sun in its various manifestations as the morning star and the evening star. (b) The line above Venus is tilted at 23.5° to the horizontal, indicating that the line represents Earth. (c) Adjusting the Earth-line by 23.5° Venus rises and falls above and below the Earth's horizon. The line shown at 90° is a reference line; when the line is moved counterclockwise by 90° it aligns with the 'Venus-line'. (d) When the Venus-line is now rotated clockwise by 177° [the angle by which Venus is tilted on its axis] it touches the Earth horizon line. This elaborate explanation confirms that the tiny circles either side of the Sun discs represent Venus, meaning that the man between the discs must be the Sun, God. This must therefore be the first picture of God.



The Mosaic Mask of Palenque
The Man who was Venus

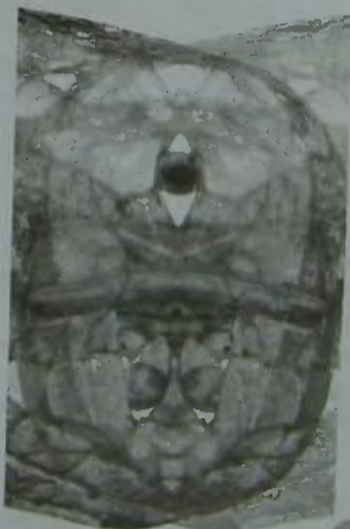

Figure 66. (a) Venus setting against the disc [eyeball] of the Sun. (b) Venus rising against the disc of the Sun. (c) Face of the Bat God. (d) Crab—the man's eyes stare at the crab's eyes located below and either side of his own. (e) Sketch of the 60-cm- (2-foot-) high golden anthropomorphic model of the crab-man found in the tomb of Viracocha Pachacamac at Sipan, Peru (see also plate 5d). The three circles on the crab's thighs also appear in (d). As mentioned earlier, the crab lives in the 'foam of the sea' and is therefore used as a metaphor to describe the perfect human being, Viracocha, in the language of the Quechua of Bolivia [ancient Peru].

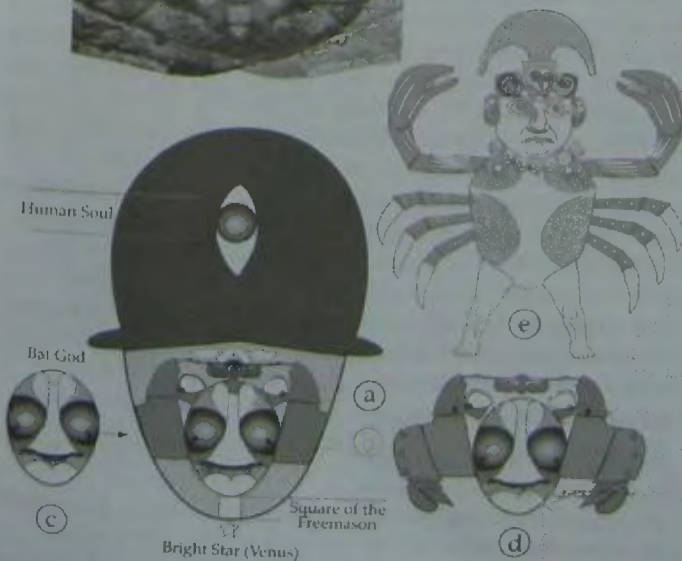



Figure 66. (a) Venus setting against the disc [eyeball] of the Sun. (b) Venus rising against the disc of the Sun. (c) Face of the bat god. (d) Crab—the man's eyes stare at the crab's eyes located below and either side of his own. (e) Sketch of the two-foot- (60-cm-) high golden anthropomorphic model of the crab-man found in the tomb of Viracocha Pachacamac at Sipan, Peru (see also plate 5d). The three circles on the crab's thighs also appear in (d). As mentioned earlier, the crab lives in the 'foam of the sea' and is therefore used as a metaphor to describe the perfect human being, Viracocha, in the language of the Quechua of Bolivia [ancient Peru].

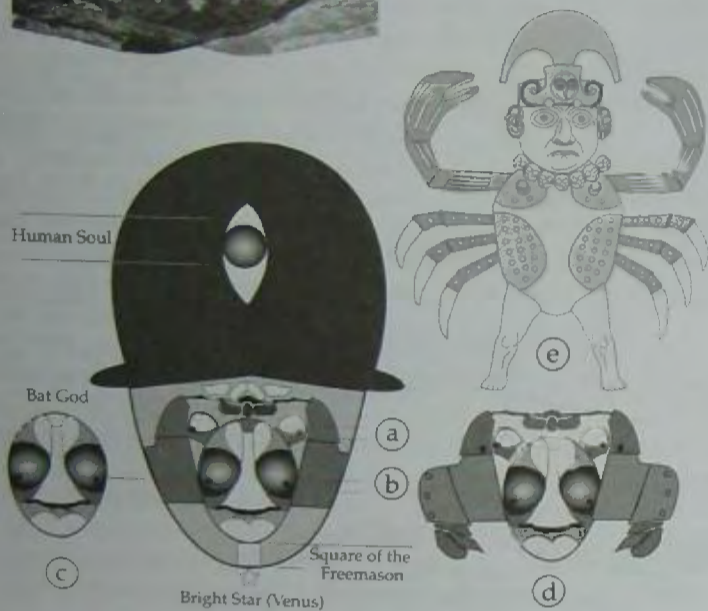

figure 42 showed Christ carrying the compasses of the Freemason set at 66° and showed the compasses formed by the spindles on the spinning wheel to be set in the same way.

Figure A26 shows a 'spider chamber' found in the tomb of Viracocha. The spider spins a silver thread which, like the analysis undertaken in figure 42, associates Viracocha with the mythical silver thread, the cable-tow that tethers the soul to the body during out-of-body sojourns. This explains why spiritual types (priests, clerics, orthodox Jews, etc.) all wear a hat when praying: to prevent the soul from leaving through the ostensible hole (spiritual gateway) we are told is located in the top of the head—should they become too close to God through prayer—before their time is up. The small man wears a hat to demonstrate the same principles.

The eagle with outstretched wings in plate 24 not only carries away the soul of the small man but also carries away the Christlike figure and his compasses (in its claws). At the same time the small man acquires wings, his spirit soars and he flies away with the eagle. The square of the Freemason appears on his chin together with a five-pointed star. All of this tells us that Lord Pacal, the Viracochas and Jesus were each, in his turn, the virtuous who became God, a bright star in the Heavens.

Moreover, this remarkable series of pictures explicitly acknowledges that 'God created man in his own image' (Genesis 1, 27). Plate 24 therefore shows the first ever picture of God and explains that man can become God, but only when man transforms the 66.6° into the 99.9° —the same message as the Grail. It seems, also, that the small man represents a picture of God on Earth, a Supergod. That this is the case is confirmed by further analysis provided by figures 65 and 66.

Whom Does the Grail Serve?

The answer to Perceval's question of 'Whom does the Grail serve?' should by now be clear. The Grail was the cup left behind by Jesus following his life on Earth. It is a tangible representation of everything he taught about the super-science of the Sun and the higher orders of spirituality.

The Theory of Divine Reconciliation (figure A19) explicitly recognises that God wishes to grow because more God is 'more love' and

The Mosaic Mask of Palenque
The First Picture of God (II)



Figure 65. Composite scene from the Mosaic Mask of Palenque (see also plate 24); The small man carries a geometric line arrangement either side of his hat (highlighted in bold white on the composite picture). The line arrangement is reproduced in the schematics below; (a) line arrangement as it appears on the composite. The arc represents the disc of the Sun. Venus is shown either side of the Sun in its various manifestations as the morning star and the evening star. (b) The line above Venus is tilted at 23.5° to the horizontal, indicating that the line represents Earth. (c) Adjusting the Earth-line by 23.5° Venus rises and falls above and below the Earth's horizon. The line shown at 90° is a reference line; when the line is moved counterclockwise by 90° it aligns with the 'Venus-line'. (d) When the Venus-line is now rotated clockwise by 177° [the angle by which Venus is tilted on its axis] it touches the Earth horizon line. This elaborate explanation confirms that the tiny circles either side of the Sun discs represent Venus, meaning that the man between the discs must be the man between the Sun, God. This must therefore be the first picture of God.

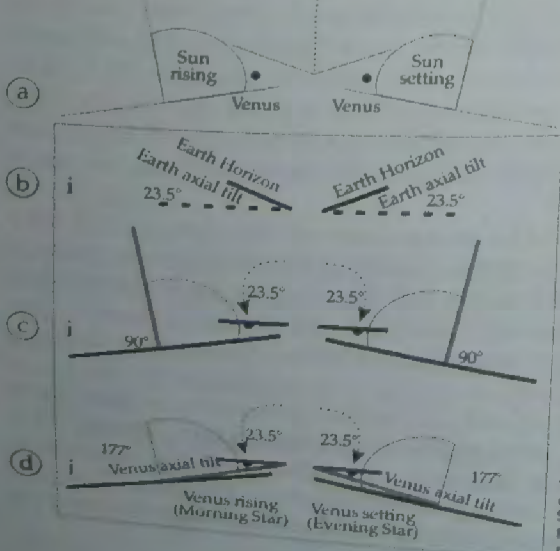

The Mosaic Mask of Palenque
The Man who was Venus



Figure 66. (a) Venus setting against the disc [eye ball] of the Sun. (b) Venus rising against the disc of the Sun. (c) Face of the Bat God. (d) Crab—the man's eyes stare at the crab's eyes located below and either side of his own. (e) Sketch of the 60-cm- (2-foot-) high golden anthropomorphic model of the crab-man found in the tomb of Viracocha Pachacamac at Sipan, Peru (see also plate 5d). The three circles on the crab's thighs also appear in (d). As mentioned earlier, the crab lives in the 'foam of the sea' and is therefore used as a metaphor to describe the perfect human being, Viracocha, in the language of the Quechua of Bolivia [ancient Peru].

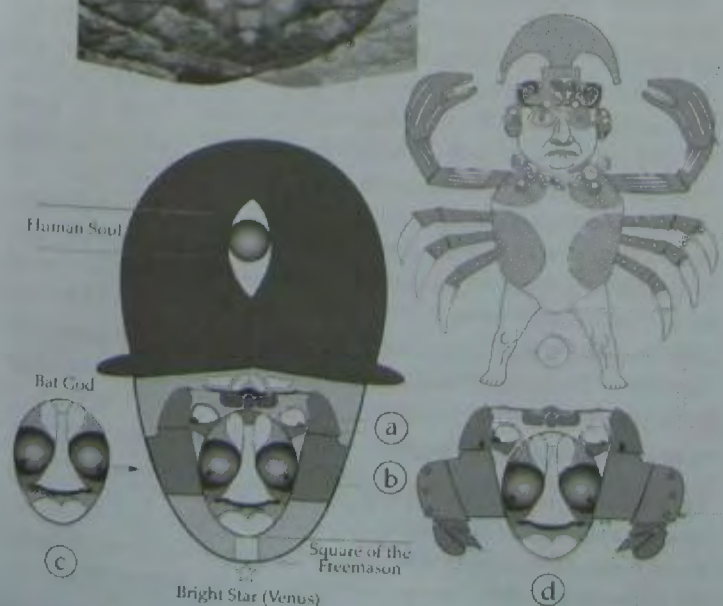

The Mosaic Mask of Palenque
The Man Who Was Venus



Figure 66. (a) Venus setting against the disc [eyeball] of the Sun. (b) Venus rising against the disc of the Sun. (c) Face of the bat god. (d) Crab—the man's eyes stare at the crab's eyes located below and either side of his own. (e) Sketch of the two-foot- (60-cm-) high golden anthropomorphic model of the crab-man found in the tomb of Viracocha Pachacamac at Sipan, Peru (see also plate 5d). The three circles on the crab's thighs also appear in (d). As mentioned earlier, the crab lives in the 'foam of the sea' and is therefore used as a metaphor to describe the perfect human being, Viracocha, in the language of the Quechua of Bolivia [ancient Peru].

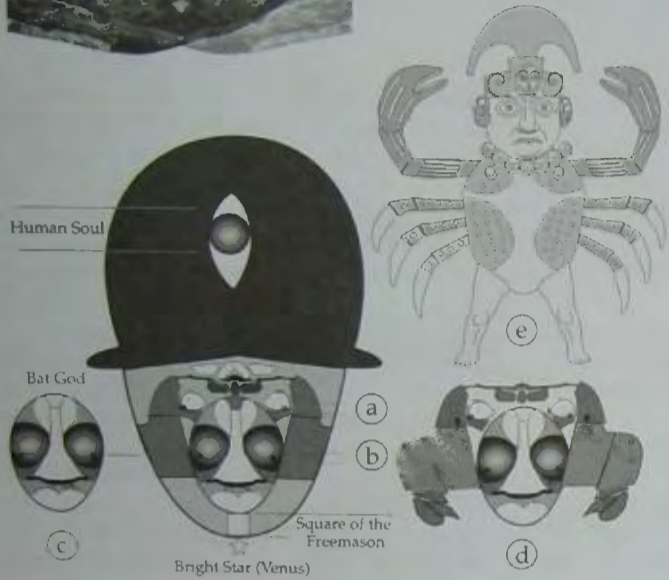

figure 42 showed Christ carrying the compasses of the Freemason set at 66° and showed the compasses formed by the spindles on the spinning wheel to be set in the same way.

Figure A26 shows a 'spider chamber' found in the tomb of Viracocha. The spider spins a silver thread which, like the analysis undertaken in figure 42, associates Viracocha with the mythical silver thread, the cable-tow that tethers the soul to the body during out-of-body sojourns. This explains why spiritual types (priests, clerics, orthodox Jews, etc.) all wear a hat when praying: to prevent the soul from leaving through the ostensible hole (spiritual gateway) we are told is located in the top of the head—should they become too close to God through prayer—before their time is up. The small man wears a hat to demonstrate the same principles.

The eagle with outstretched wings in plate 24 not only carries away the soul of the small man but also carries away the Christlike figure and his compasses (in its claws). At the same time the small man acquires wings, his spirit soars and he flies away with the eagle. The square of the Freemason appears on his chin together with a five-pointed star. All of this tells us that Lord Pacal, the Viracochas and Jesus were each, in his turn, the virtuous who became God, a bright star in the Heavens.

Moreover, this remarkable series of pictures explicitly acknowledges that 'God created man in his own image' (Genesis I, 27). Plate 24 therefore shows the first ever picture of God and explains that man can become God, but only when man transforms the 66.6° into the 99.9°—the same message as the Grail. It seems, also, that the small man represents a picture of God on Earth, a Supergod. That this is the case is confirmed by further analysis provided by figures 65 and 66.

Whom Does the Grail Serve?

The answer to Perceval's question of 'Whom does the Grail serve?' should by now be clear. The Grail was the cup left behind by Jesus following his life on Earth. It is a tangible representation of everything he taught about the super-science of the Sun and the higher orders of spirituality.

The Theory of Divine Reconciliation (figure A19) explicitly recognises that God wishes to grow because more God is 'more love' and

The Mosaic Mask of Palenque
The First Picture of God (II)



Figure 65. Composite scene from the Mosaic Mask of Palenque (see also plate 24); The small man carries a geometric line arrangement either side of his hat (highlighted in bold white on the composite picture). The line arrangement is reproduced in the schematics below; (a) line arrangement as it appears on the composite. The arc represents the disc of the Sun. Venus is shown either side of the Sun in its various manifestations as the morning star and the evening star. (b) The line above Venus is tilted at 23.5° to the horizontal, indicating that the line represents Earth. (c) Adjusting the Earth-line by 23.5° Venus rises and falls above and below the Earth's horizon. The line shown at 90° is a reference line; when the line is moved counterclockwise by 90° it aligns with the 'Venus-line'. (d) When the Venus-line is now rotated clockwise by 177° [the angle by which Venus is tilted on its axis] it touches the Earth horizon line. This elaborate explanation confirms that the tiny circles either side of the Sun discs represent Venus, meaning that the man between the discs must be the Sun, God. This must therefore be the first picture of God.

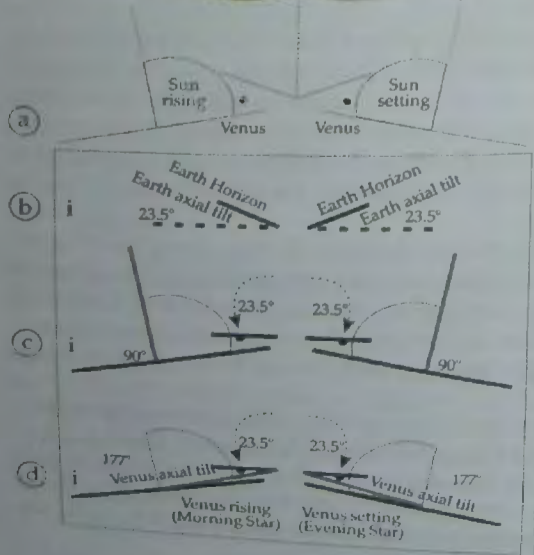

The Mosaic Mask of Palenque
The Man who was Venus

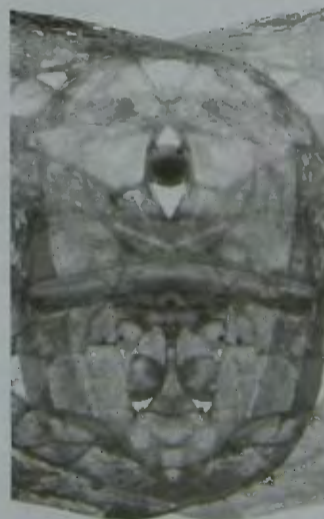
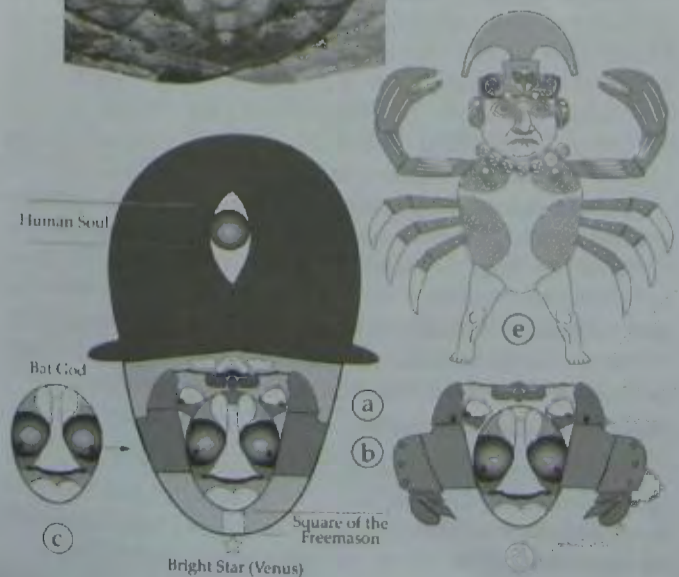

Figure 66. (a) Venus setting against the disc [eye ball] of the Sun. (b) Venus rising against the disc of the Sun. (c) Face of the Bat God. (d) Crab—the man's eyes stare at the crab's eyes located below and either side of his own. (e) Sketch of the 60-cm- (2-foot-) high golden anthropomorphic model of the crab-man found in the tomb of Viracocha Pachacamac at Sipan, Peru (see also plate 5d). The three circles on the crab's thighs also appear in (d). As mentioned earlier, the crab lives in the 'foam of the sea' and is therefore used as a metaphor to describe the perfect human being, Viracocha, in the language of the Quechua of Bolivia [ancient Peru].



therefore 'more good'. But by 'making man in his own image' we learn that God cannot grow except through using living organisms as a conduit to accommodate spiritual growth. The Grail, that is to say the esoteric knowledge contained in the Grail, therefore, serves God.

Jesus sacrificed his life to convey the important message to the living of the day, and to those who would live later. Like Lord Pacal he ensured that his Holy Cup would be passed on, generation after generation, touching all who understood the esoteric knowledge.

We have already heard of how, during the Last Supper, Jesus introduced the cup to his Disciples:

... And as they were eating bread Jesus blessed it and gave it to the Disciples and said, take eat, this is my body ... and he took the cup and gave thanks and gave it to them saying drink ye all of it ... for this is my blood of the New Testament which is shed for many for the remission of sins. (*Matthew XXVI, 26-28*)

What happened later is seldom mentioned: knowing that the end was near, Jesus went with his Disciples to pray on the mountain. During the collective prayers he withdrew—within earshot of the Disciples—for private prayer during which he enigmatically referred to the legacy he would leave behind for others:

Father; if thou be willing remove this cup from me. (*Luke XXII, 42*)

O my Father, if it be possible, let this cup pass from me, not as I will but as your will. (*Matthew XXVI, 39*)

In so doing Jesus introduced the esoteric nature of the Grail to his Disciples, who were thereafter charged with its safekeeping.

The Celtic swastikas, spirals, knot-work, numbering system, Excalibur, the Grail and the illuminated manuscripts all convey the exact same information found in the treasures of the world's sun-worshipping civilizations: the soul really can become a star.

compasses are comprised of the same lines previously described as Earth-lines in the figure 65 analysis. They were set at 23.5° to the horizontal and at 66.5° (90° - 23.5°) to the vertical. The Christ-like figure thus carries each leg of the compasses at 66° to himself. Earlier, figure 42 showed Christ carrying the compasses of the Freemason set at 66° and figure 42 showed the compasses, formed by the spindles on the spinning wheel, to be set in the same way.

Figure A26 shows a 'spider-chamber' found in the tomb of Viracocha. The spider spins a silver thread which, like the analysis undertaken in figure 42, associates Viracocha with the mythical silver thread, the cable-tow that tethers the soul to the body during out of body sojourns. This explains why spiritual types (priests, clerics, orthodox Jews etc.) all wear a hat when praying; to prevent the soul from leaving through the ostensible hole (spiritual gateway) we are told is located in the top of the head—should they become too close to God through prayer—before their time is up. The small man wears a hat to demonstrate the same principles.

The eagle with outstretched wings in plate 24 not only carries away the soul of the small man but also carries away the Christ-like figure and his compasses (in its claws). At the same time the small man acquires wings, his spirit soars and he flies away with the eagle. The square of the freemason appears on his chin together with a five-pointed star. All of this tells us that Lord Pacal, the Viracochas and Jesus were each, in their turn, the virtuous who became God, a bright star in the Heavens.

Moreover, this remarkable series of pictures explicitly acknowledges that 'God created man in his own image' (Genesis I, 27). Plate 24 therefore shows the first ever picture of God and explains that man can become God, but only when man transforms the 66.6° into the 99.9°—the same message as the Grail. It seems, also, that the small man represents a picture of God on Earth, a Supergod. That this is the case is confirmed by further analysis provided by figures 65 and 66.

Whom does the Grail Serve?

The answer to Perceval's question of 'Whom does the Grail serve?' should by now be clear. The Grail was the cup left behind by Jesus following his life on Earth. It is a tangible representation of everything he taught about the super-science of the Sun and the higher orders of spirituality.

Decoding the Viracocha Transformer

The best accounts of Peruvian mythology come from Spanish chroniclers around the time of the conquest in AD 1532. One of these, Cieza de Leon, a native Peruvian, from the age of thirteen, spent ten years living among the indigenous Indians of the new colony. Eventually, gaining their confidence, he was able to share in the legends of their ancestors. His book, the *Crónica del Perú*, was published in 1550, at the age of thirty-two:

Before the Incas ruled or had even been heard of in these kingdoms these Indians relate a thing more noteworthy than anything else. They say that there suddenly appeared, coming from the south, a white man of large stature and authoritative demeanour. This man had such great power that he changed the hills into valleys and from the valleys made great hills, causing streams to flow from the living stone. When they saw his power they called him Maker of all things created and Prince of all things, Father of the Sun. For he did other still more wonderful things, giving being to men and animals; by his hand very great benefits accrued to them. This is the story that the Indians themselves told me and they heard it from their fathers who in turn heard it from the old songs which were handed down from very ancient times.

They say that this man travelled along the highland route to the north, working marvels as he went and they say they never

The Theory of Divine Reconciliation (figure A19) explicitly recognises that God wishes to grow because more God is 'more love' and therefore 'more good'. But, by 'making man in his own image' we learn that God cannot grow except through using living organisms as a conduit to accommodate spiritual growth. The Grail, that is to say the esoteric knowledge contained in the Grail, therefore, serves God.

Jesus sacrificed his life to convey the important message to the living of the day, and to those who would live later. Like Lord Pacal he ensured that his holy cup would be passed-on, generation after generation, touching all who understood the esoteric knowledge.

We have already heard of how, during the Last Supper, Jesus introduced the Cup to his Disciples:

... And as they were eating bread Jesus blessed it and gave it to the Disciples and said, take eat, this is my body ... and he took the cup and gave thanks and gave it to them saying drink ye all of it ... for this is my blood of the New Testament which is shed for many for the remission of sins. *Matthew XXVI, 26-28*.

What happened later is seldom mentioned; knowing that the end was near, Jesus went with his Disciples to pray on the mountain. During the collective prayers he withdrew—within ear-shot of the Disciples—for private prayer during which he enigmatically referred to the legacy he would leave behind for others:

Father; if thou be willing remove this cup from me. *Luke XXII, 42*

O my Father, if it be possible, let this cup pass from me, not as I will but as your will. *Matthew XXVI, 39*.

In so doing Jesus introduced the esoteric nature of the Grail to his Disciples who were thereafter charged with its safekeeping.

The Celtic swastikas, spirals, knot-work, numbering system, Excalibur, the Grail and the illuminated manuscripts all convey the exact same information found in the treasures of the world's sun worshipping civilizations: the soul really can become a star.

therefore 'more good'. But by 'making man in his own image' we learn that God cannot grow except through using living organisms as a conduit to accommodate spiritual growth. The Grail, that is to say the esoteric knowledge contained in the Grail, therefore, serves God.

Jesus sacrificed his life to convey the important message to the living of the day, and to those who would live later. Like Lord Pacal he ensured that his Holy Cup would be passed on, generation after generation, touching all who understood the esoteric knowledge.

We have already heard of how, during the Last Supper, Jesus introduced the cup to his Disciples:

... And as they were eating bread Jesus blessed it and gave it to the Disciples and said, take eat, this is my body ... and he took the cup and gave thanks and gave it to them saying drink ye all of it ... for this is my blood of the New Testament which is shed for many for the remission of sins. (*Matthew XXVI, 26-28*)

What happened later is seldom mentioned: knowing that the end was near, Jesus went with his Disciples to pray on the mountain. During the collective prayers he withdrew—within earshot of the Disciples—for private prayer during which he enigmatically referred to the legacy he would leave behind for others:

Father; if thou be willing remove this cup from me. (*Luke XXII, 42*)

O my Father, if it be possible, let this cup pass from me, not as I will but as your will. (*Matthew XXVI, 39*)

In so doing Jesus introduced the esoteric nature of the Grail to his Disciples, who were thereafter charged with its safekeeping.

The Celtic swastikas, spirals, knot-work, numbering system, Excalibur, the Grail and the illuminated manuscripts all convey the exact same information found in the treasures of the world's sun-worshipping civilizations: the soul really can become a star.

APPENDIX ONE

Decoding the Viracocha Transformer

The best accounts of Peruvian mythology come from Spanish chroniclers around the time of the conquest in AD 1532. One of these, Cieza de Leon, a native Peruvian, from the age of thirteen, spent ten years living among the indigenous Indians of the new colony. Eventually, gaining their confidence, he was able to share in the legends of their ancestors. His book, the *Crónica del Perú*, was published in 1550, at the age of thirty-two:

Before the Incas ruled or had even been heard of in these kingdoms these Indians relate a thing more noteworthy than anything else. They say that there suddenly appeared, coming from the south, a white man of large stature and authoritative demeanour. This man had such great power that he changed the hills into valleys and from the valleys made great hills, causing streams to flow from the living stone. When they saw his power they called him Maker of all things created and Prince of all things, Father of the Sun. For he did other still more wonderful things, giving being to men and animals; by his hand very great benefits accrued to them. This is the story that the Indians themselves told me and they heard it from their fathers who in turn heard it from the old songs which were handed down from very ancient times.

They say that this man travelled along the highland route to the north, working marvels as he went and they say they never

APPENDIX ONE

Decoding the Viracocha Transformer

The best accounts of Peruvian mythology come from Spanish chroniclers around the time of the conquest in AD 1532. One of these, Cieza de Leon, a native Peruvian from the age of 13, spent 10 years living among the indigenous Indians of the new Colony. Eventually, gaining their confidence, he was able to share in the legends of their ancestors. His book, the *Crónica del Perú*, was published in 1550, at the age of 32:

Before the Incas ruled or had even been heard of in these kingdoms these Indians relate a thing more noteworthy than anything else. They say that there suddenly appeared, coming from the south, a white man of large stature and authoritative demeanour. This man had such great power that he changed the hills into valleys and from the valleys made great hills, causing streams to flow from the living stone. When they saw his power they called him Maker of all things created and Prince of all things, Father of the Sun. For he did other still more wonderful things, giving being to men and animals; by his hand very great benefits accrued to them. This is the story that the Indians themselves told me and they heard it from their fathers who in turn heard it from the old songs which were handed down from very ancient times.

They say that this man travelled along the highland route to the north.

The Lands of Lord Pacal and Viracocha

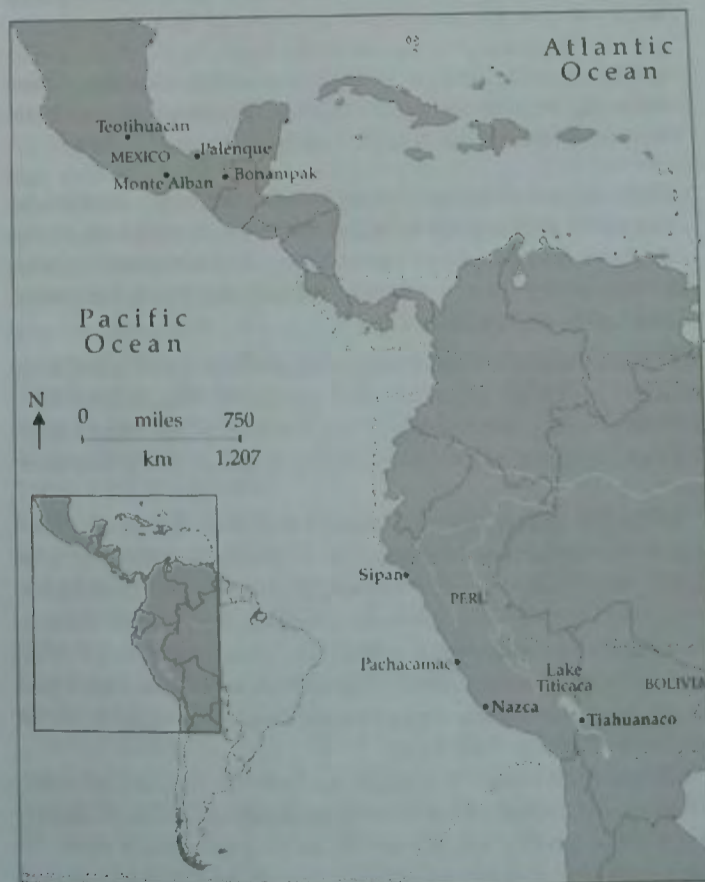

Figure A1.

saw him again. They say that in many places he gave men instructions on how they should live, speaking to them with great love and kindness, admonishing them to be good and to do no damage or injury one to another, but to love one another and show charity to all. In most places they call him Viracocha. In many places they built temples to him and in them they set up statues in his likeness and offered sacrifices before them. The huge statues in the village of Tiahuanaco are held to be from those times. (Cieza de Leon, *Crónica del Perú*, Part II, Ch. 4)

They narrate further, that, leaving the place where this occurred, he came to the coast and there, holding his mantle, he went forth amidst the waves of the sea and was seen no more. And as he went they gave him the name Viracocha, which in their language means 'foam of the sea'. (*Crónica del Perú*, Part II, Ch. 5)

When we examine the myth, the historical accounts, from this and other sources, we learn that a legendary white god named Viracocha journeyed from the ancient city of Tiahuanaco, by the waters of Lake Titicaca in the Bolivian highlands, and travelled the length of Peru performing miracles.

In *The Lost Tomb of Viracocha* I showed that Viracocha actually lived and walked the lands of Peru more than 1,500 years ago after tracing his journey from Tiahuanaco to his treasure-filled tomb in the Huaca Rajada, a mud-brick pyramid complex near the small Mochica town of Sipan on Peru's northwest coast. The tomb had been discovered earlier, in 1990, by archaeologist Dr. Walter Alva, director of the Bruning Archaeological Museum, who never made the connection between the occupant of the tomb and the stories of the Incas.

Archaeologists named the man in the tomb the 'Old Lord of Sipan'. His tomb was stocked with all kinds of treasures that would in time reveal his true identity; one particularly striking piece was a 60-cm- (2-foot-) high gilded copper anthropomorphic figure (plate 5d) sporting the face of the occupant of the tomb, attached to the body of a large crab, a creature that lives both on land and in the sea, in between the land and the sea, in the 'foam of the sea', the translation of which becomes 'Viracocha'.

Soon it became clear that here, in the long-lost pyramids of Sipan,

The Lands of Lord Pacal and Viracocha

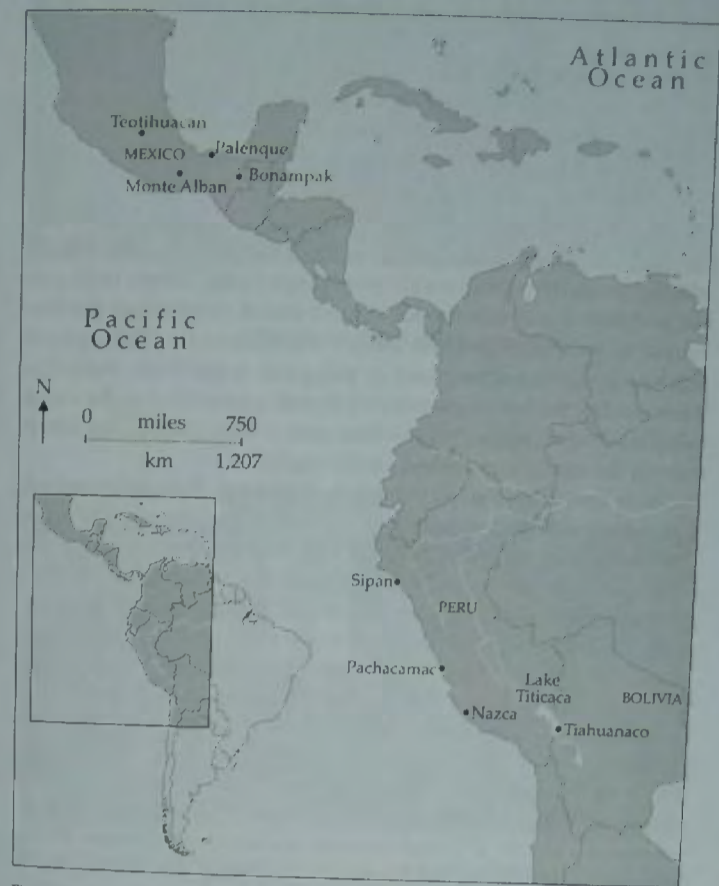

Figure A1.

APPENDIX ONE

Decoding the Viracocha Transformer

The best accounts of Peruvian mythology come from Spanish chroniclers around the time of the conquest in AD 1532. One of these, Cieza de Leon, a native Peruvian from the age of 13, spent 10 years living among the indigenous Indians of the new Colony. Eventually, gaining their confidence, he was able to share in the legends of their ancestors. His book, the *Crónica del Perú*, was published in 1550, at the age of 32;

Before the Incas ruled or had even been heard of in these kingdoms these Indians relate a thing more noteworthy than anything else. They say that there suddenly appeared, coming from the south, a white man of large stature and authoritative demeanour. This man had such great power that he changed the hills into valleys and from the valleys made great hills, causing streams to flow from the living stone. When they saw his power they called him Maker of all things created and Prince of all things, Father of the Sun. For he did other still more wonderful things, giving being to men and animals; by his hand very great benefits accrued to them. This is the story that the Indians themselves told me and they heard it from their fathers who in turn heard it from the old songs which were handed down from very ancient times.

They say that this man travelled along the highland route to the north,

The Lands of Lord Pacal and Viracocha

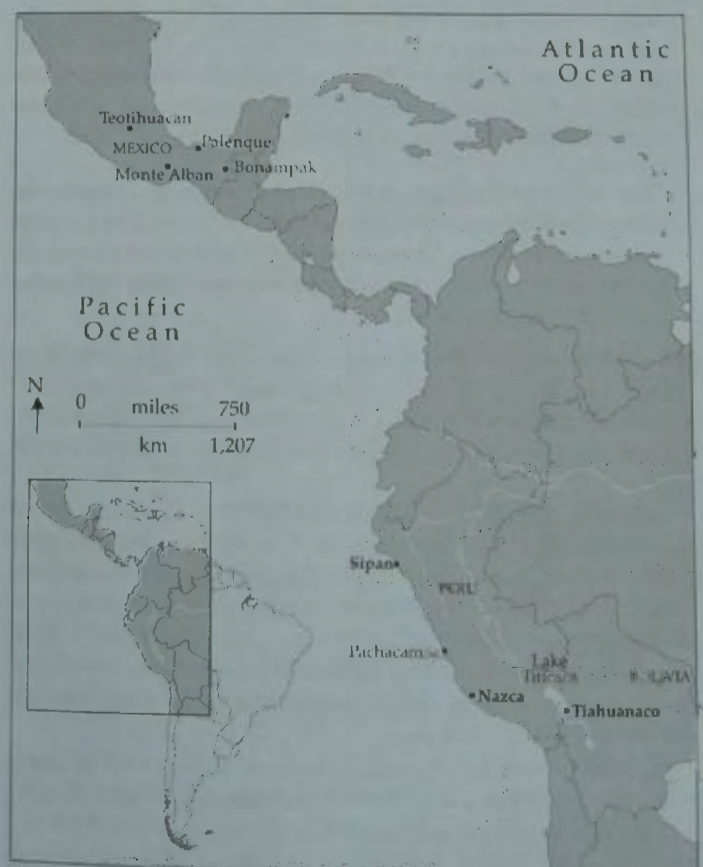

Figure A1.

The Lands of Lord Pacal and Viracocha

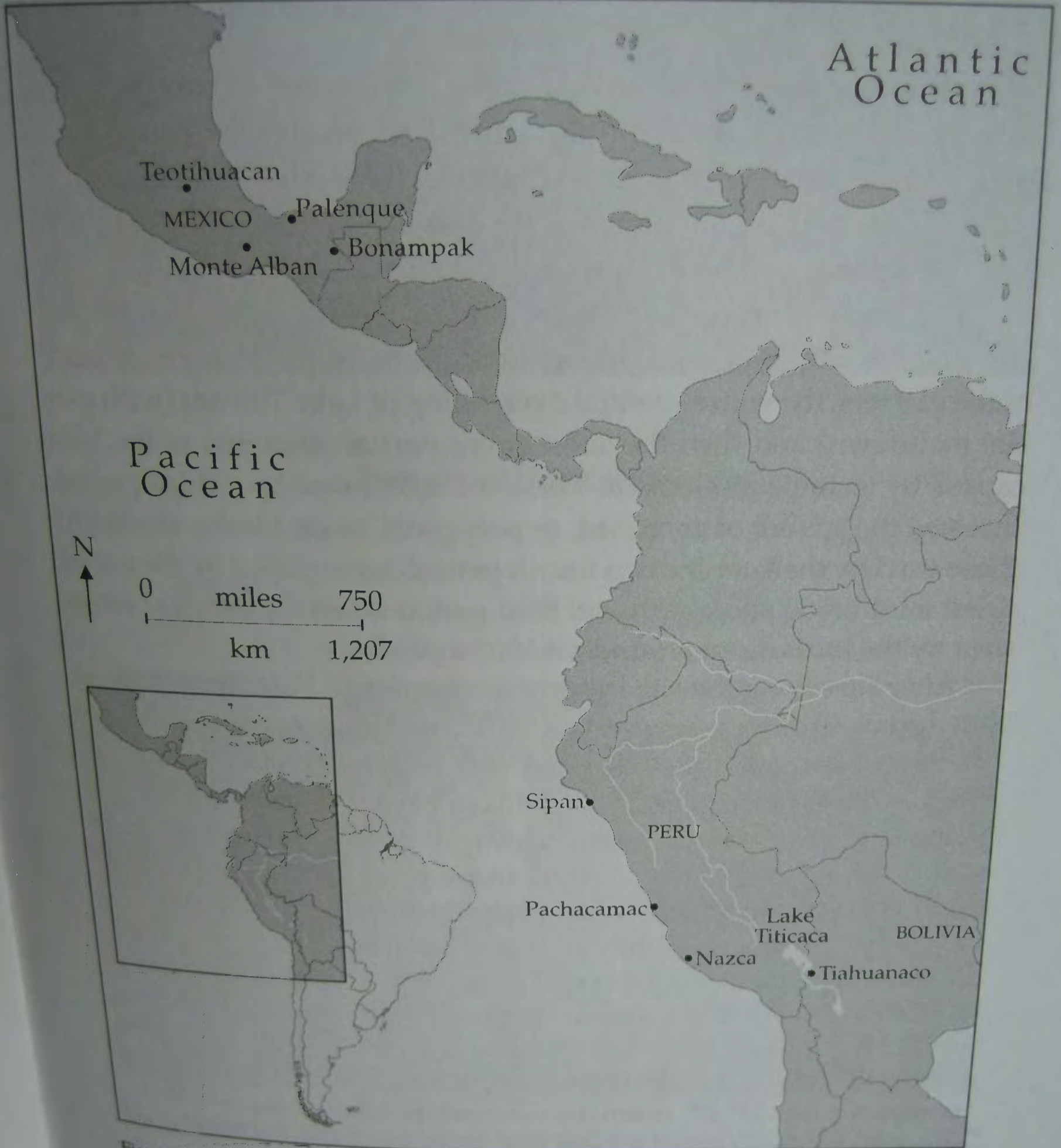

Figure A1.

lay the bones of Viracocha, the legendary white god who had sidestepped the annals of history. The story of the white man with the beard, revered throughout South America, was not just a myth after all.

The Secrets of Tiahuanaco

Bolivian archaeologist Arthur Posnansky was one of the first academics to question the foundation date of the ancient city of Tiahuanaco (figure A2), located 4,000 metres (13,000 feet) high in the Bolivian altiplano (the high plain). Sedimentation and lake-level samples allowed him to set down the development of the site into five epochs, or periods. The first period corresponded with the geological upheaval that elevated the altiplano from the ocean floor; the second, to the melting of the glaciers, the consequential over-filling of Lake Titicaca (with glacial meltdown) and then the subsequent partial emptying of the lake caused by tectonic movement. These were followed by a third period that saw the advent of encased, or polygonal, stone blocks, similar to those used by the later Incas; a fourth period, exemplified by the use of dried mud-brick; and a fifth and final period when the city was taken over by the Incas, from around AD 1300 to 1538.

After surveying the site in considerable detail, Posnansky noticed that the lateral angles, between the cornerstones of one of the temples (figures A2 and A3), the Kalasasaya (the Temple of Standing Stones), and a partially buried observational lava block that once marked the location of the monolithic stone Gateway of the Sun (figure A3a), measured $23^{\circ} 8' 48''$, a figure very close to the present-day angle of tilt of the Earth on its axis (the obliquity of the Earth).

Further investigation showed that the Sun would rise above each corner of the Kalasasaya entranceway at the time of the solstices, 21st December and 21st June, were it not for a slight discrepancy: the Sun would have risen exactly above the corners had the tilt of the Earth amounted to $23^{\circ} 8' 48''$, which it did not; the tilt of the Earth when he measured it was $23^{\circ} 27'$, much the same as it is today. Posnansky therefore was convinced that the Earth had tilted, albeit very slightly, since the site was constructed in antiquity.

In 1958 Bolivian archaeologist Carlo Ponce Sangines sank more than 500 shafts into the ground around Lake Titicaca searching for

THE CELTIC CHRONICLES

working marvels as he went and they say they never saw him again. They say that in many places he gave men instructions on how they should live, speaking to them with great love and kindness, admonishing them to be good and to do no damage or injury one to another, but to love one another and show charity to all. In most places they call him Viracocha. In many places they built temples to him and in them they set up statues in his likeness and offered sacrifices before them. The huge statues in the village of Tiahuanaco are held to be from those times. Cieza de Leon, *Crónica del Perú*, Part II, Ch. 4.

They narrate further, that, leaving the place where this occurred, he came to the coast and there, holding his mantle, he went forth amidst the waves of the sea and was seen no more. And as he went they gave him the name Viracocha, which in their language means 'foam of the sea'. *Crónica del Perú*, Part II, Ch. 5.

When we examine the myth, the historical accounts, from this and other sources, we learn that a legendary white god named Viracocha journeyed from the ancient city of Tiahuanaco, by the waters of Lake Titicaca in the Bolivian highlands, and travelled the length of Peru performing miracles.

In *The Last Tomb of Viracocha* I showed that Viracocha actually lived and walked the lands of Peru more than 1,500 years ago after tracing his journey from Tiahuanaco to his treasure-filled tomb in the Huaca Rajada, a mud-brick pyramid complex near the small Mochica town of Sipan on Peru's north-west coast. The tomb had been discovered earlier, in 1990, by archaeologist Dr Walter Alva, Director of the Bruning Archaeological Museum who never made the connection between the occupant of the tomb and the stories of the Incas.

Archaeologists named the man in the tomb the 'Old Lord of Sipan'. His tomb was stocked with all kinds of treasures that would in time reveal his true identity; one particularly striking piece was a 60cm- (2-foot-) high gilded copper anthropomorphic figure (plate 5d) sporting the face of the occupant of the tomb, attached to the body of a large crab, a creature that lives both on land and in the sea, in-between the land and the sea, in the 'foam of the sea'. The translation of which becomes 'Viracocha'.

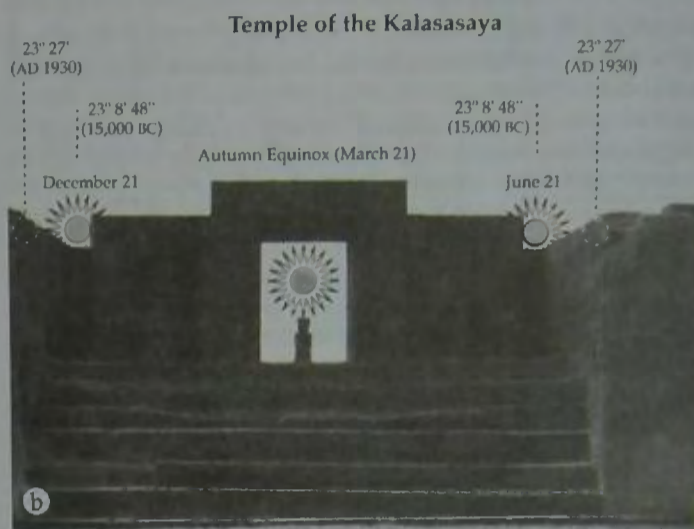
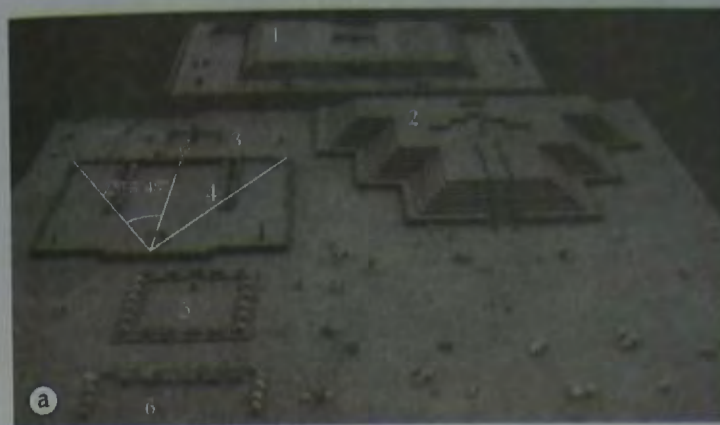

Figure A2. (a) Aerial view of Tiahuanaco, Bolivia (reconstruction): 1. Kanta, 2. Akapana, 3. Temple of Stone Heads, 4. Kalasasaya, Temple of the Standing Stones; the lateral angles shown, according to Professor Arthur Posnansky in 1914, enumerate astronomical information (see main text). 5. Putuni, 6. Kerikala. (b) Kalasasaya stairway [viewed from the direction of the white arrow in (a)]; Posnansky also noticed that the Sun would rise above the statue of Viracocha in the centre of the Kalasasaya stairway at the time of the southern hemisphere autumn equinox and above the corners of the stairway at the time of the solstices.

Soon it became clear that here, in the long-lost pyramids of Sipan, lay the bones of Viracocha, the legendary white god who had sidestepped the annals of history. The story of the white man with the beard, revered throughout South America was not just a myth after all.

The Secrets of Tiahuanaco

Bolivian archaeologist Arthur Posnansky was one of the first academics to question the foundation date of the ancient city of Tiahuanaco (figure A2) located 4,000 metres (13,000 feet) high in the Bolivian altiplano (the high plain). Sedimentation and lake level samples allowed him to set down the development of the site into five epochs, or periods. The first period corresponded with the geological upheaval that elevated the altiplano from the ocean floor; the second to the melting of the glaciers, consequential over-filling of lake Titicaca (with glacial meltdown) and then the subsequent partial emptying of the lake caused by tectonic movement. These were followed by a third period that saw the advent of encased, or polygonal, stone blocks, similar to those used by the later Incas; a fourth period, exemplified by the use of dried mud-brick and, finally, a fifth and final period when the city was taken-over by the Incas, from around AD 1300-1538.

After surveying the site in considerable detail Posnansky noticed that the lateral angles, between the corner stones of one of the temples (figures A2 and A3), the Kalasasaya (the Temple of Standing Stones), and a partially buried observational lava block that once marked the location of the monolithic stone Gateway of the Sun (figure A3a) measured $23^{\circ} 8' 48''$, a figure very close to the present-day angle of tilt of the Earth on its axis (the obliquity of the Earth).

Further investigation showed that the Sun would rise above each corner of the Kalasasaya entranceway at the time of the solstices, 21st December and 21st June, were it not for a slight discrepancy; the Sun would have risen exactly above the corners had the tilt of the Earth amounted to $23^{\circ} 8' 48''$, which it did not, the tilt of the Earth when he measured it was $23^{\circ} 27'$, much the same as it is today. Posnansky therefore was convinced that the Earth had tilted, albeit very slightly, since the site was constructed in antiquity.

In 1958 Bolivian archaeologist Carlo Ponce Sangines sank more than

Tiahuanaco, Bolivia

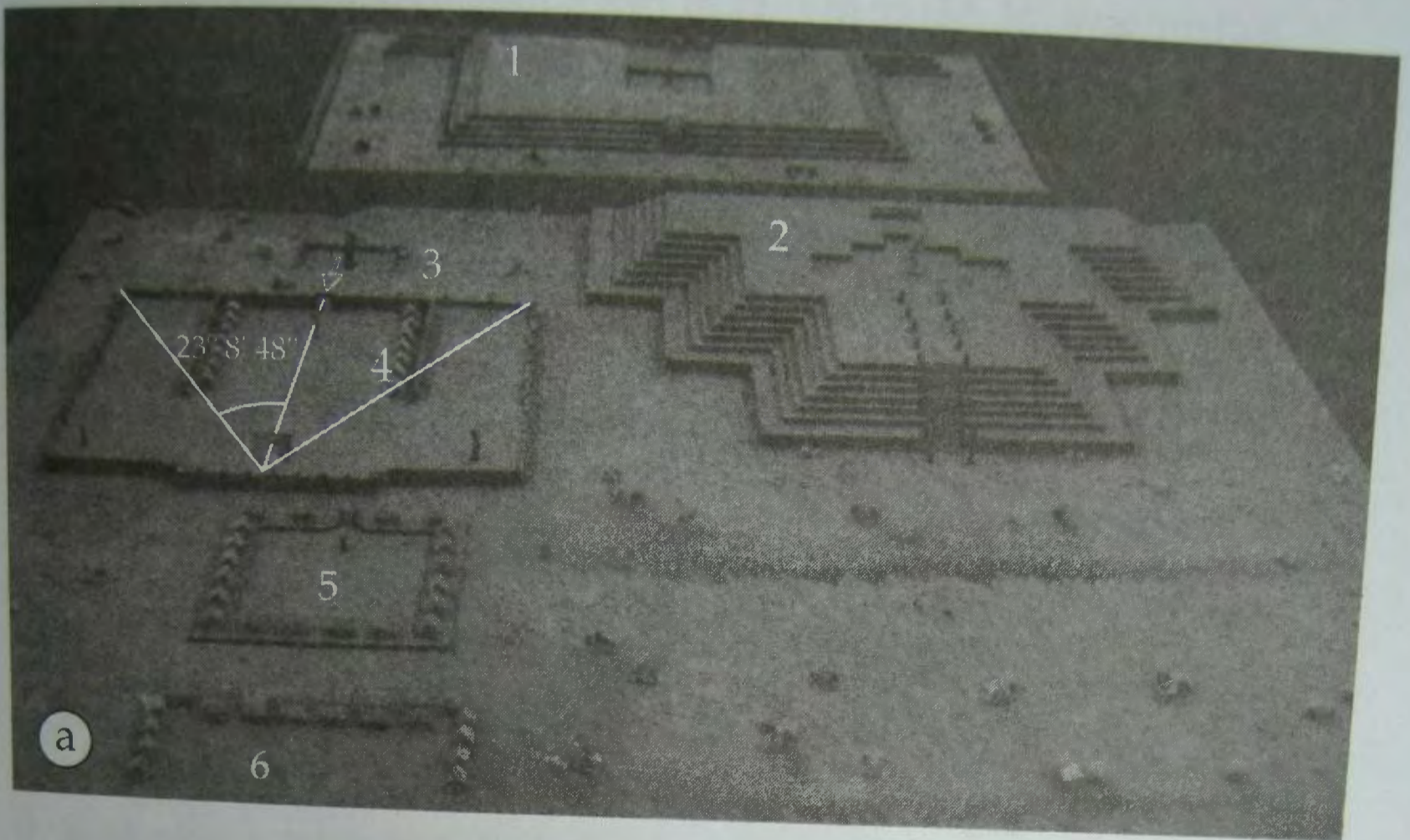

Temple of the Kalasasaya

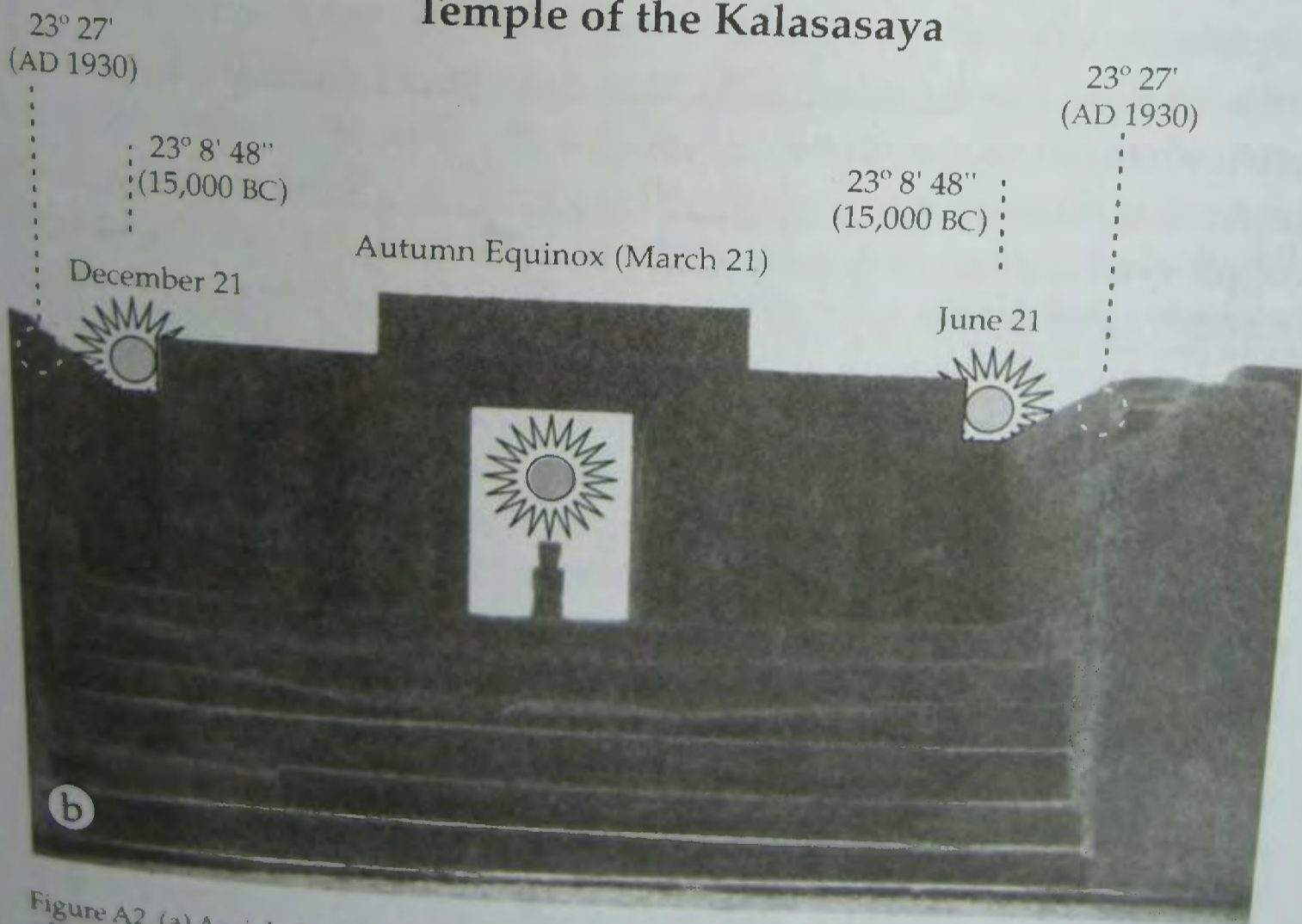

Figure A2. (a) Aerial view of Tiahuanaco, Bolivia (reconstruction): 1. Kanta, 2. Akapana, 3. Temple of Stone Heads, 4. Kalasasaya, Temple of the Standing Stones; the lateral angles shown, according to Professor Arthur Posnansky in 1914, enumerate astronomical information (see main text), 5. Putuni, 6. Kerikala. (b) Kalasasaya stairway [viewed from the direction of the white arrow in (a)]; Posnansky also noticed that the Sun would rise above the statue of Viracocha in the centre of the Kalasasaya stairway at the time of the southern hemisphere autumn equinox and above the corners of the stairway at the time of the solstices.

lay the bones of Viracocha, the legendary white god who had side-stepped the annals of history. The story of the white man with the beard, revered throughout South America, was not just a myth after all.

The Secrets of Tiahuanaco

Bolivian archaeologist Arthur Posnansky was one of the first academics to question the foundation date of the ancient city of Tiahuanaco (figure A2), located 4,000 metres (13,000 feet) high in the Bolivian altiplano (the high plain). Sedimentation and lake-level samples allowed him to set down the development of the site into five epochs, or periods. The first period corresponded with the geological upheaval that elevated the altiplano from the ocean floor; the second, to the melting of the glaciers, the consequential over-filling of Lake Titicaca (with glacial meltdown) and then the subsequent partial emptying of the lake caused by tectonic movement. These were followed by a third period that saw the advent of enclashed, or polygonal, stone blocks, similar to those used by the later Incas; a fourth period, exemplified by the use of dried mud-brick; and a fifth and final period when the city was taken over by the Incas, from around AD 1300 to 1538.

After surveying the site in considerable detail, Posnansky noticed that the lateral angles, between the cornerstones of one of the temples (figures A2 and A3), the Kalasasaya (the Temple of Standing Stones), and a partially buried observational lava block that once marked the location of the monolithic stone Gateway of the Sun (figure A3a), measured $23^{\circ} 8' 48''$, a figure very close to the present-day angle of tilt of the Earth on its axis (the obliquity of the Earth).

Further investigation showed that the Sun would rise above each corner of the Kalasasaya entranceway at the time of the solstices, 21st December and 21st June, were it not for a slight discrepancy: the Sun would have risen exactly above the corners had the tilt of the Earth amounted to $23^{\circ} 8' 48''$, which it did not; the tilt of the Earth when he measured it was $23^{\circ} 27'$, much the same as it is today. Posnansky therefore was convinced that the Earth had tilted, albeit very slightly, since the site was constructed in antiquity.

In 1958 Bolivian archaeologist Carlo Ponce Sangines sank more than 500 shafts into the ground around Lake Titicaca searching for

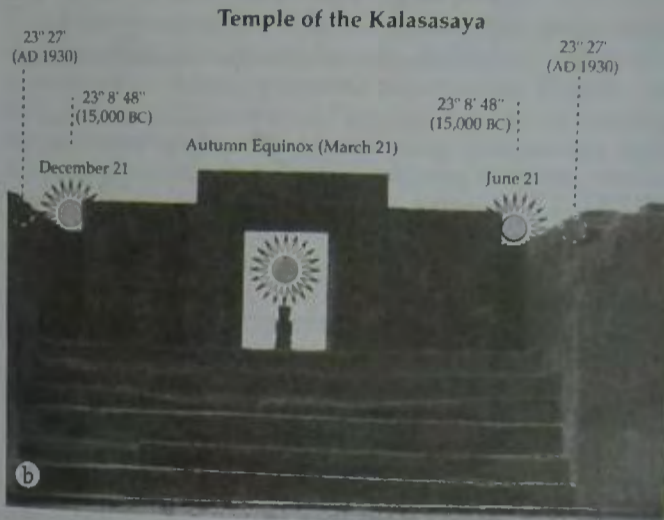
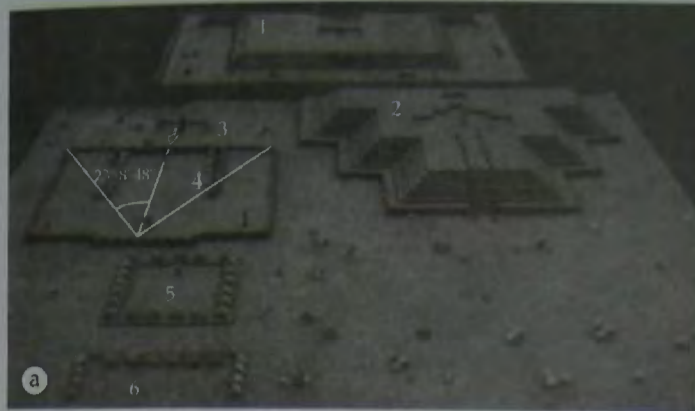

Figure A2. (a) Aerial view of Tiahuanaco, Bolivia (reconstruction): 1. Kanta, 2. Akapana, 3. Temple of Stone Heads, 4. Kalasasaya, Temple of the Standing Stones; the lateral angles shown, according to Professor Arthur Posnansky in 1914, enumerate astronomical information (see main text), 5. Putuni, 6. Kerikala. (b) Kalasasaya stairway [viewed from the direction of the white arrow in (a)]; Posnansky also noticed that the Sun would rise above the statue of Viracocha in the centre of the Kalasasaya stairway at the time of the southern hemisphere autumn equinox and above the corners of the stairway at the time of the solstices.

Tiahuanaco, Bolivia

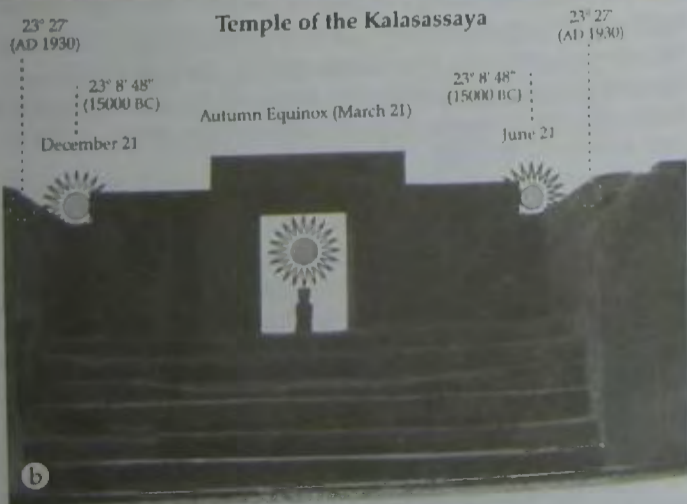

Figure A2. (a) Aerial view of Tiahuanaco, Bolivia (reconstruction): 1. Kanta, 2. Akapana, 3. Temple of Stone Heads, 4. Kalasasaya, Temple of the Standing Stones; the lateral angles shown, according to Professor Arthur Posnansky in 1914, enumerate astronomical information (see main text), 5. Putuni, 6. Kerikala. (b) Kalasasaya stairway [viewed from the direction of the white arrow in (a)]; Posnansky also noticed that the Sun would rise above the statue of Viracocha in the centre of the Kalasasaya stairway at the time of the southern hemisphere autumn equinox and above the corners of the stairway at the time of the solstices.

five hundred shafts into the ground around Lake Titicaca searching for more clues buried in the layers of strata. He divided the development of Tiahuanaco into three phases using the latest (1940s) Carbon 14 dating methods; the 'Formative', 200-1 BC, the 'Urban', 10-AD 400 and the 'Imperial', AD 400-AD 1300. Sangines uncovered five separate towns each on top of the other, successively destroyed by earthquakes and volcanic eruptions.

In the 1950's the scientist Immanuel Velikovsky pointed out that science was at a loss to explain how coal deposits could have developed in the ice-cold tundra of the Antarctic where no trees grow, how fossilised palm trees could have established themselves at Spitzbergen in the arctic circle, which for months of the year is deprived of daylight, and how perfectly preserved long-haired woolly mammoths, discovered under layers of Siberian permafrost with buttercups clenched between their teeth and undigested food in their stomachs, could possibly have survived in an area where no food grows.

Velikovsky was convinced that the Earth, at some time in the past, must have tilted on its axis, not gradually, but instantly, each time by a massive amount, causing catastrophic calamity across the globe. Areas once positioned at the Poles would have been repositioned at the equator and at the same time the hot equatorial regions would have flipped-over into the polar regions instantly freezing mammoths. Massive tidal waves would have swept across continents burying forests under miles of mud, mountains would have been levelled while sea-level plains would have been lifted high into the skies; accounting for the presence of large quantities of seashells in places like Tiahuanaco, 4,000 metres (13,000 feet) above sea-level.

[Some researchers claim that this can never happen, after all, the ice-caps are known to be millions of years old, proving that the caps (and therefore the Earth) could never have moved in the past—because if they had moved they would have melted and new caps would have formed. But this objection may be overcome as follows; ice ages on Earth are characterised by the increase in the size of the polar caps. No one understands how ice ages are caused. As Immanuel Velikovsky points out—ice caps are made from fresh water. More rain or snow is therefore required to make more ice. But if temperatures fall then there is less evapo-

Astronomical Alignments at the Kalasasaya, Tiahuanaco

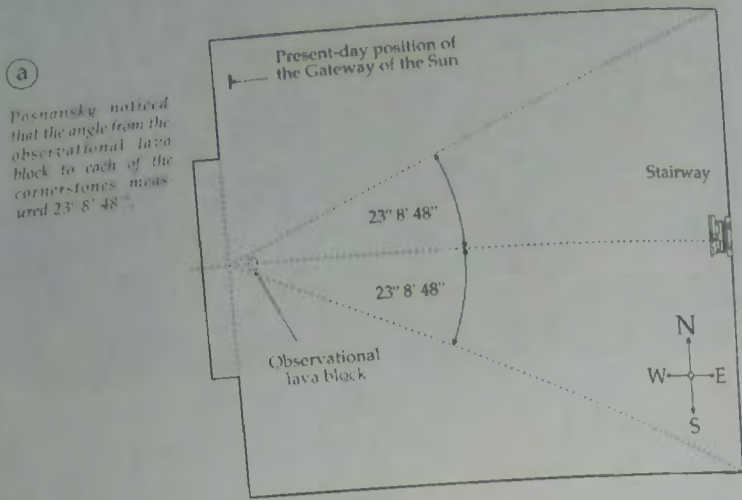

(a) Posnansky noticed that the angle from the observational lava block to each of the cornerstones measured 23° 8' 48".

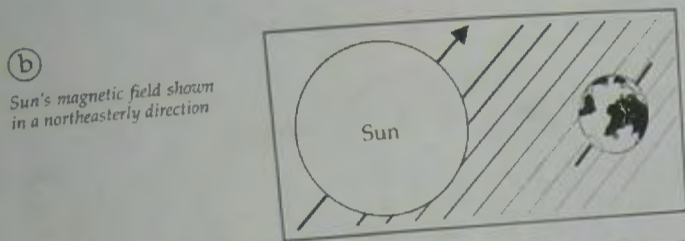

(b) Sun's magnetic field shown in a northeasterly direction

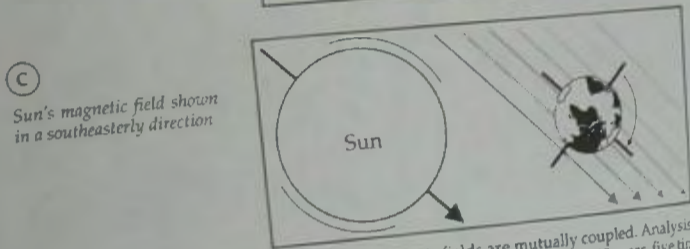

(c) Sun's magnetic field shown in a southeasterly direction

Figure A3. (a) and (b) The Sun and Earth's magnetic fields are mutually coupled. Analysis of sunspot activity shows that the Sun's magnetic field shifts direction after 3,740 years, five times every 18,139 years (one long cosmic cycle). Sometimes, in a worst-case scenario, the Earth flips on its axis, realigning its magnetic field to that of the Sun. When this happens, catastrophic destruction frequents Earth.

Astronomical Alignments at the Kalasasaya, Tiahuanaco

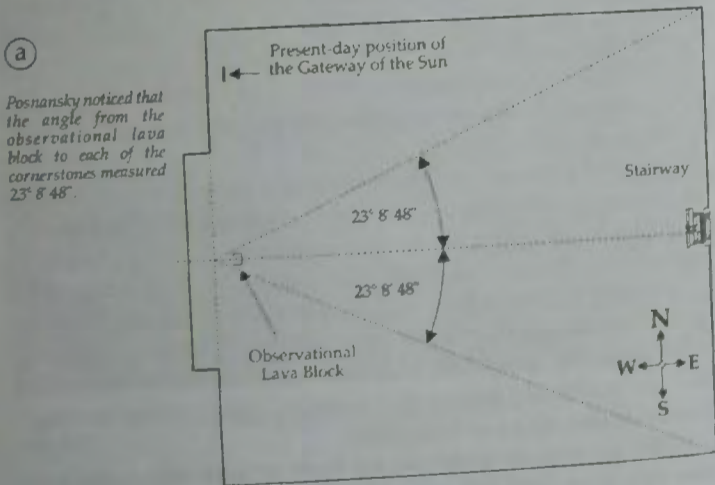

(a) Posnansky noticed that the angle from the observational lava block to each of the cornerstones measured 23° 8' 48".

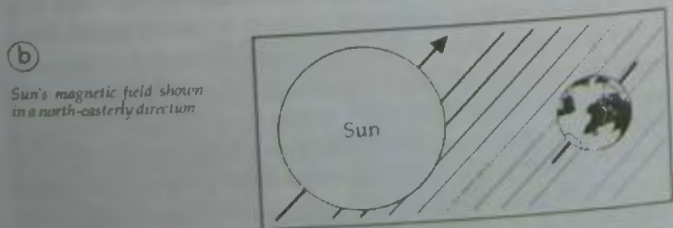

(b) Sun's magnetic field shown in a north-easterly direction

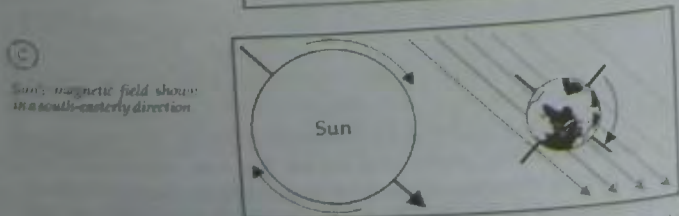

(c) Sun's magnetic field shown in a south-easterly direction

Figure A3. (a and b) The Sun and Earth's magnetic fields are mutually coupled. Analysis of sunspot activity shows that the Sun's magnetic field shifts direction after 3,740 years, five times every 18,139 years (one long cosmic cycle). Sometimes, in a worst-case scenario, the Earth flips on its axis, realigning its magnetic field to that of the Sun. When this happens catastrophic destruction frequents Earth.

more clues buried in the layers of strata. He divided the development of Tiahuanaco into three phases using the latest (1940s) carbon 14 dating methods: the 'Formative', 200-1 BC; the 'Urban', 10-AD 400; and the 'Imperial', AD 400-AD 1300. Sangines uncovered five separate towns each on top of the other, successively destroyed by earthquakes and volcanic eruptions.

In the 1950s the scientist Immanuel Velikovsky pointed out that science was at a loss to explain how coal deposits could have developed in the ice-cold tundra of the Antarctic where no trees grow, how fossilised palm trees could have established themselves at Spitzbergen in the arctic circle, which for months of the year is deprived of daylight, and how perfectly preserved long-haired woolly mammoths, discovered under layers of Siberian permafrost with buttercups clenched between their teeth and undigested food in their stomachs, could possibly have survived in an area where no food grows.

Velikovsky was convinced that the Earth, at some time in the past, must have tilted on its axis, not gradually, but instantly, each time by a massive amount, causing catastrophic calamity across the globe. Areas once positioned at the poles would have been repositioned at the equator and at the same time the hot equatorial regions would have flipped over into the polar regions, instantly freezing mammoths. Massive tidal waves would have swept across continents burying forests under miles of mud; mountains would have been levelled; while sea-level plains would have been lifted high into the skies, which would account for the presence of large quantities of seashells in places like Tiahuanaco, 4,000 metres (13,000 feet) above sea level.

[Some researchers claim that this can never happen; after all, the ice caps are known to be millions of years old, proving that the caps (and therefore the Earth) could never have moved in the past—because if they had moved, they would have melted and new caps would have formed. But this objection may be overcome as follows: ice ages on Earth are characterised by the increase in the size of the polar caps. No one understands how ice ages are caused. As Immanuel Velikovsky points out, ice caps are made from fresh water. More rain or snow is therefore required to make more ice. But if temperatures fall, then there is less evaporation of water from the world's oceans. Less evaporation means less cloud, less rain and less snow, meaning that ice caps cannot

ration of water from the World's oceans. Less evaporation means less cloud, less rain and less snow, meaning that ice caps cannot grow when temperatures fall. Conversely, when temperatures increase there is more evaporation, but the warmer temperatures cause the ice caps to melt and shrink, not grow. Velikovsky pointed out that the only way ice caps could be made to grow would be for the Earth to heat up from the inside. That would cause the oceans to evaporate more easily. Rain and snow would increase, increasing the size of the ice caps. That is where Velikovsky ended his enquiry. But taking this mechanism one step further; if the Earth heats up from within then the polar caps will become slushy at the interface with the planet (underneath the polar cap). When the Earth tilts off its axis the ice caps will be left behind as the Earth beneath slides on a layer of slush. Thus the Earth can still tilt off its axis and the polar ice cores will retain their true age going back millions of years, because the polar caps would remain stationary with respect to space. That this has happened in the past is borne out by the presence of massive stones and boulders that today litter open fields around the world. Geologists maintain that they have been deposited by melting glaciers but it is much more likely that the moving Earth, beneath the caps, dragged the boulders into position. Moreover, when the Sun's magnetic field twists and the Earth does not twist off its axis the Sun and Earth's magnetic fields will be mis-aligned. The mis-aligned magnetic fields will cause electrical currents to flow in the Earth's molten magma core. The Earth will increase in temperature and the scenario above will be set into motion. It is also interesting to note that such a phenomenon would increase pressure within the core causing increasing volcanic activity and the blowing of super-volcanoes.]

We know, from studying the treasures of the Maya and the super-science of the Sun, that the Sun's twisting magnetic field (figure A3) causes Earth-tilts (commonly referred to as pole-shifts). It seems that the ancient Tiahuanaco's, in drawing our attention to the change in the tilt of the Earth were attempting, at Tiahuanaco, to tell modern man that their own civilization was destroyed when the Earth tilted on its axis. This is a clue to understanding the meaning of the bas relief carving featured on the lintel of the Gateway of the Sun at Tiahuanaco. Decoding of the sun

Astronomical Alignments at the Kalasasaya, Tiahuanaco

(a)

Posnansky noticed that the angle from the observational lava block to each of the cornerstones measured $23^{\circ} 8' 48''$.

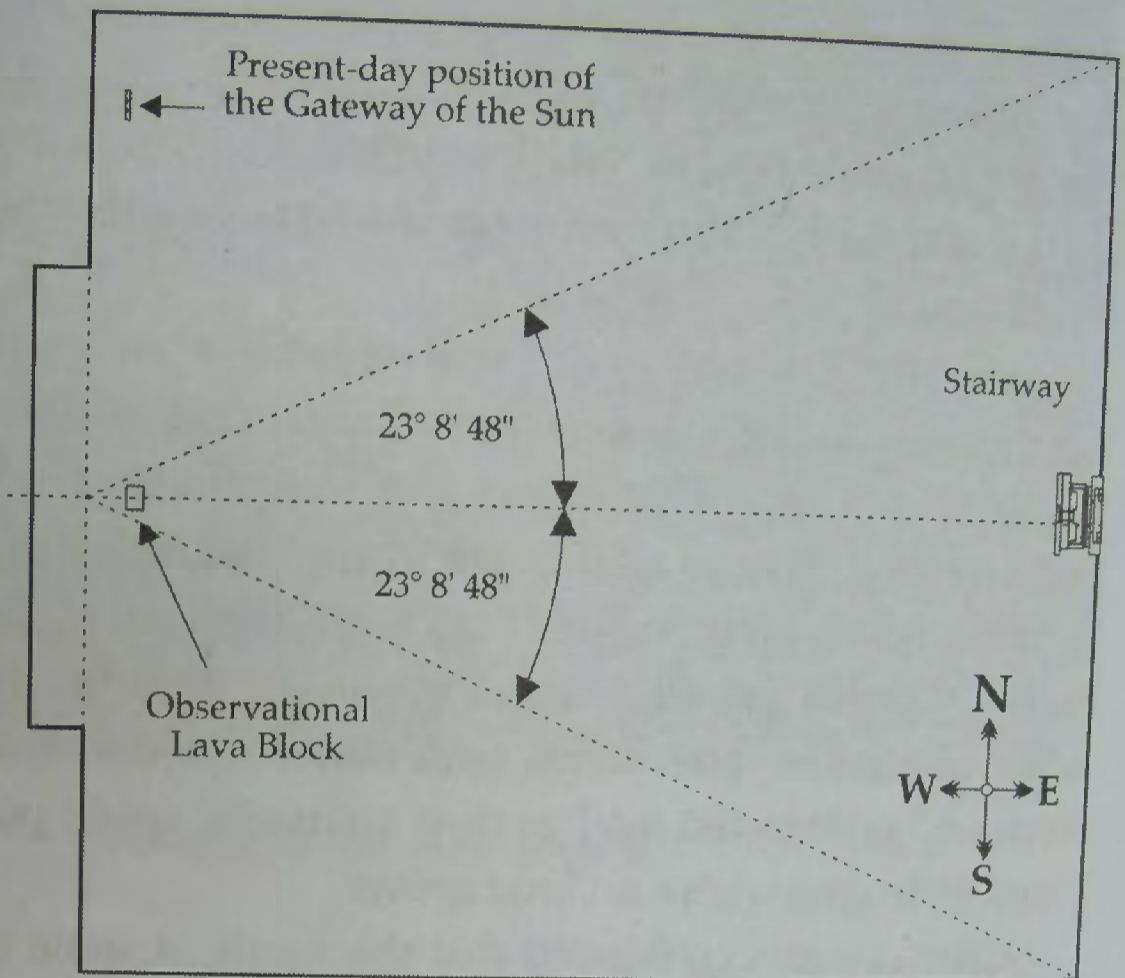

(b)

Sun's magnetic field shown in a north-easterly direction

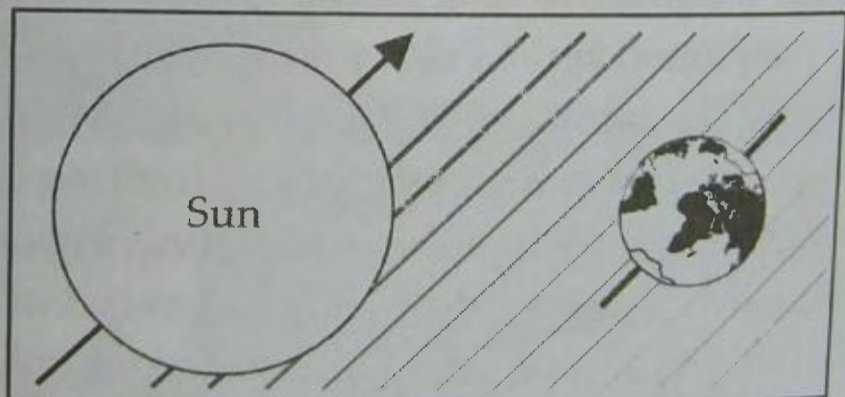

(c)

Sun's magnetic field shown in a south-easterly direction

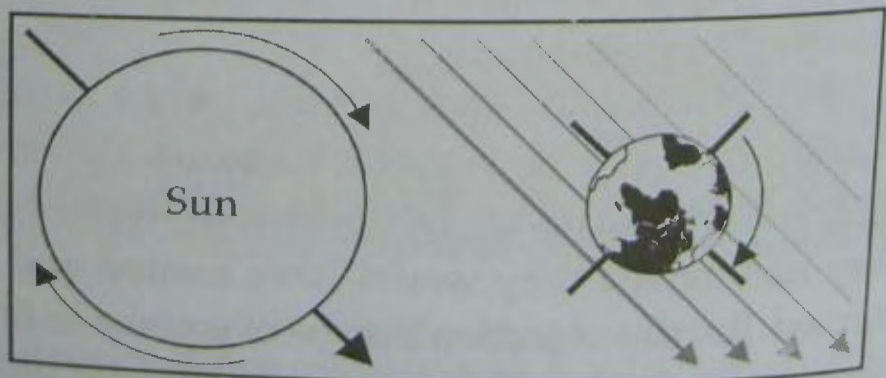

Figure A3. (a and b) The Sun and Earth's magnetic fields are mutually coupled. Analysis of sunspot activity shows that the Sun's magnetic field shifts direction after 3,740 years, five times every 18,139 years (one long cosmic cycle). Sometimes, in a worst-case scenario, the Earth flips on its axis, realigning its magnetic field to that of the Sun. When this happens catastrophic destruction frequents Earth.

grow when temperatures *fall*. Conversely, when temperatures *increase*, there is more evaporation, but the warmer temperatures cause the ice caps to melt and *shrink*, not grow. Velikovsky pointed out that the only way ice caps could be made to *grow* would be for the Earth to heat up *from the inside*. That would cause the oceans to evaporate more easily. Rain and snow would increase, increasing the size of the ice caps. That is where Velikovsky ended his enquiry. But taking this mechanism one step further: if the Earth heats up from *within*, then the polar caps will become slushy at the interface with the planet (underneath the polar cap). When the Earth tilts off its axis, the ice caps will be left behind as the Earth beneath slides on a layer of slush. Thus the Earth can still tilt off its axis and the polar ice cores will retain their true age going back millions of years, because the polar caps would remain stationary with respect to space. That this has happened in the past is borne out by the presence of massive stones and boulders that today litter open fields around the world. Geologists maintain that they have been *deposited* by *melting* glaciers but it is much more likely that the moving Earth, beneath the caps, dragged the boulders into position. Moreover, when the Sun's magnetic field twists and the Earth does *not* twist off its axis, the Sun and Earth's magnetic fields will be misaligned. The misaligned magnetic fields will cause electrical currents to flow in the Earth's molten magma core. The Earth will increase in temperature and the scenario above will be set into motion. It is also interesting to note that such a phenomenon would increase pressure within the core, causing increasing volcanic activity and the blowing of super-volcanoes.]

We know, from studying the treasures of the Maya and the super-science of the Sun, that the Sun's twisting magnetic field (figure A3) causes Earth-tilts (commonly referred to as pole-shifts). It seems that the ancient Tiahuanacos, in drawing our attention to the change in the tilt of the Earth, were attempting, at Tiahuanaco, to tell modern man that their own civilisation was destroyed when the Earth tilted on its axis. This is a clue to understanding the meaning of the bas-relief carving featured on the lintel of the Gateway of the Sun at Tiahuanaco (figure A4). Decoding of the sun shield of Monte Alban (plates 2 and 3) and analysis of the decoding (figure 9) revealed the southern point of the Star of David poking into the mouth of the Viracocha bas-relief carving.

Gateway of the Sun, Tiahuanaco, Bolivia

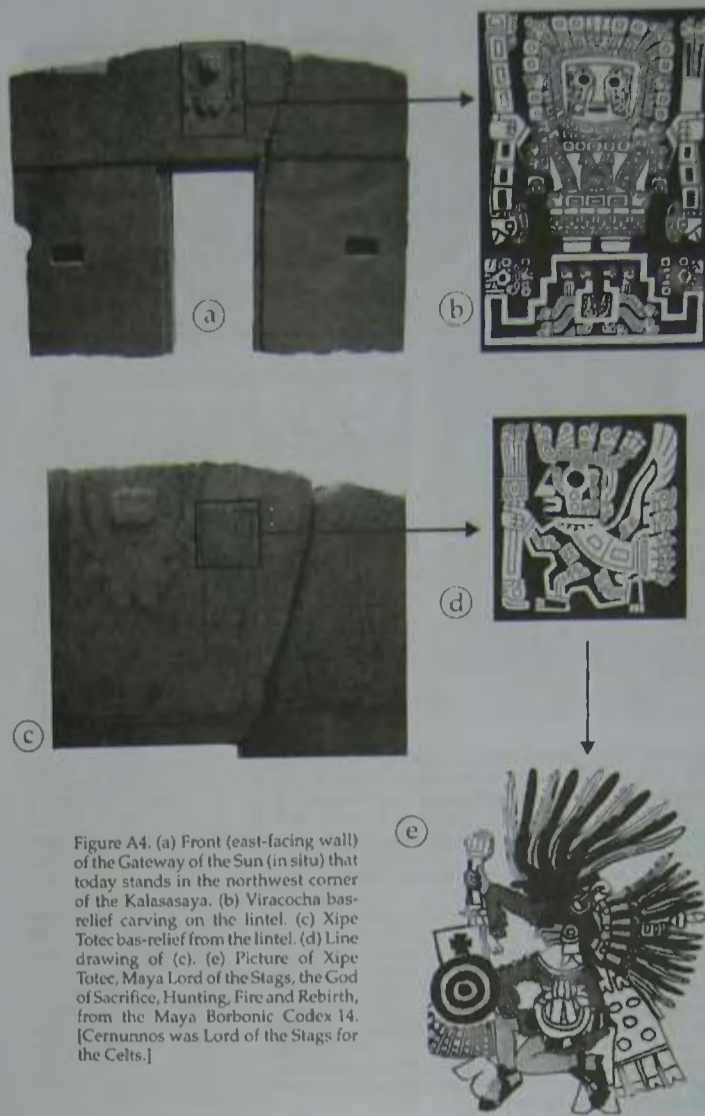

Figure A4. (a) Front (east-facing wall) of the Gateway of the Sun (in situ) that today stands in the northwest corner of the Kalasasaya. (b) Viracocha bas-relief carving on the lintel. (c) Xipe Totec bas-relief from the lintel. (d) Line drawing of (c). (e) Picture of Xipe Totec, Maya Lord of the Stags, the God of Sacrifice, Hunting, Fire and Rebirth, from the Maya Borbonic Codex 14. [Cernunnos was Lord of the Stags for the Celts.]

Gateway of the Sun, Tiahuanaco, Bolivia

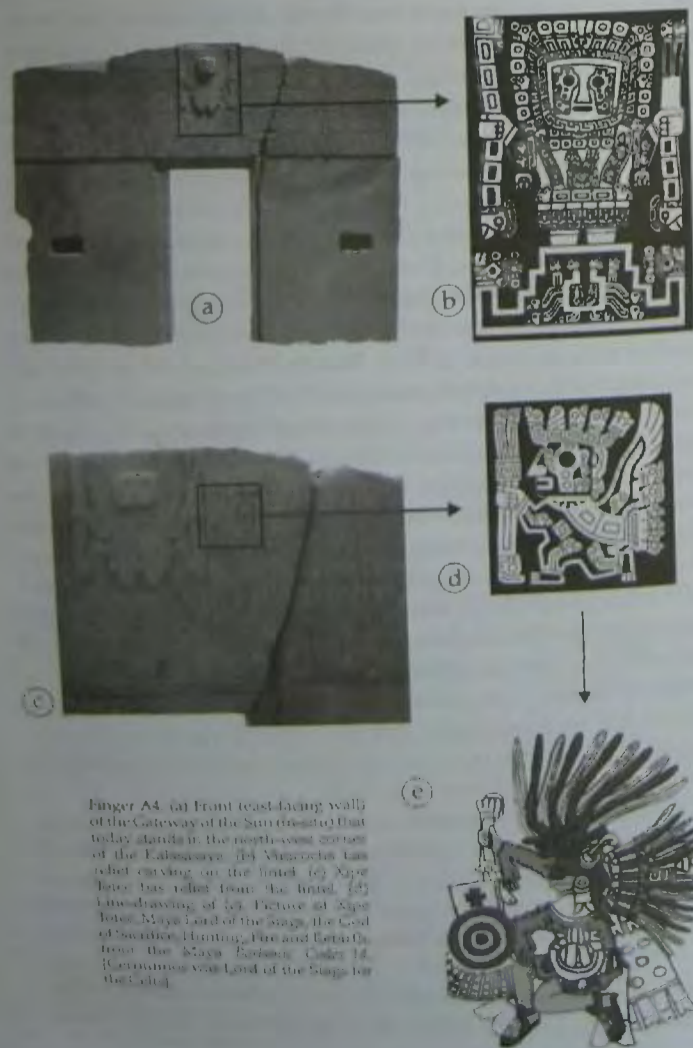

Figure A4. (a) Front (east-facing wall) of the Gateway of the Sun (in situ) that today stands in the northwest corner of the Kalasasaya. (b) Viracocha bas-relief carving on the lintel. (c) Xipe Totec bas-relief from the lintel. (d) Line drawing of (c). (e) Picture of Xipe Totec, Maya Lord of the Stags, the God of Sacrifice, Hunting, Fire and Rebirth, from the Maya Borbonic Codex 14. [Cernunnos was Lord of the Stags for the Celts.]

Cracking the Code of the Viracocha Transformer (I)

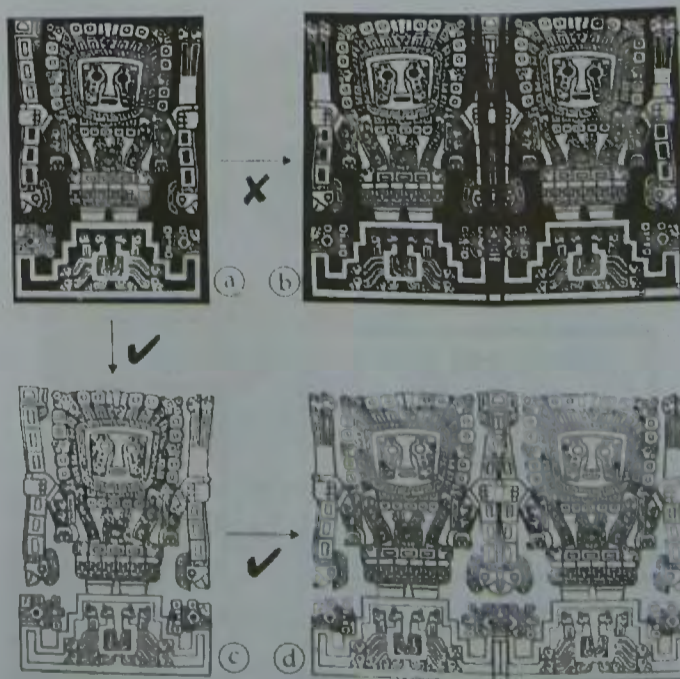
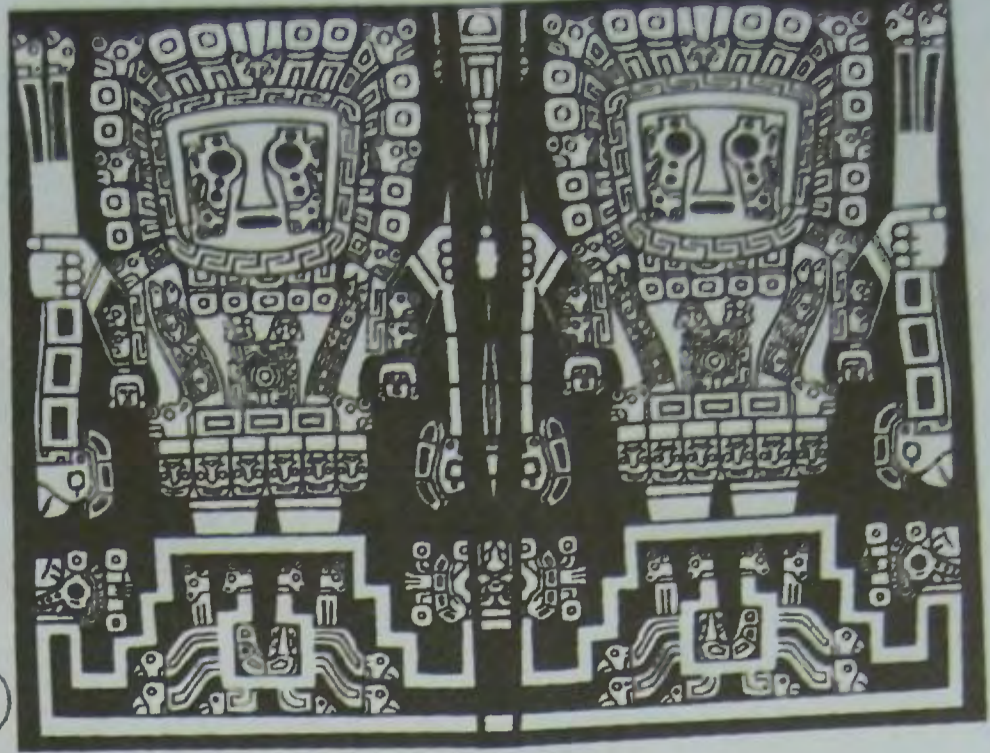
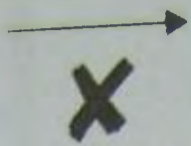
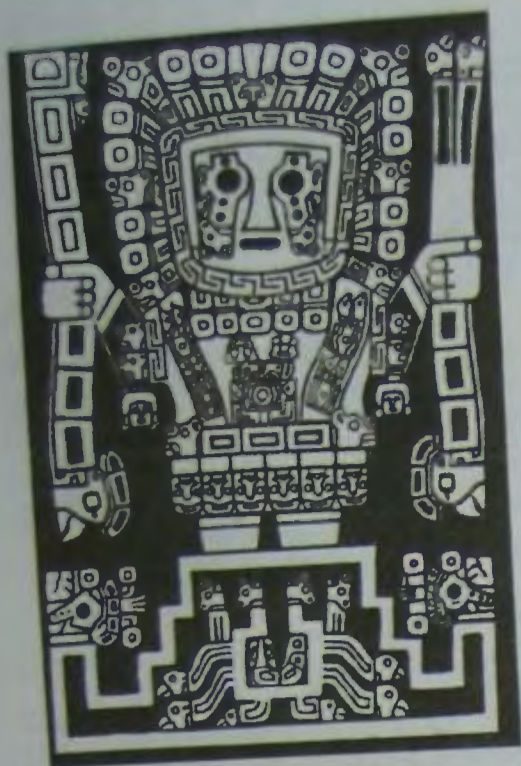
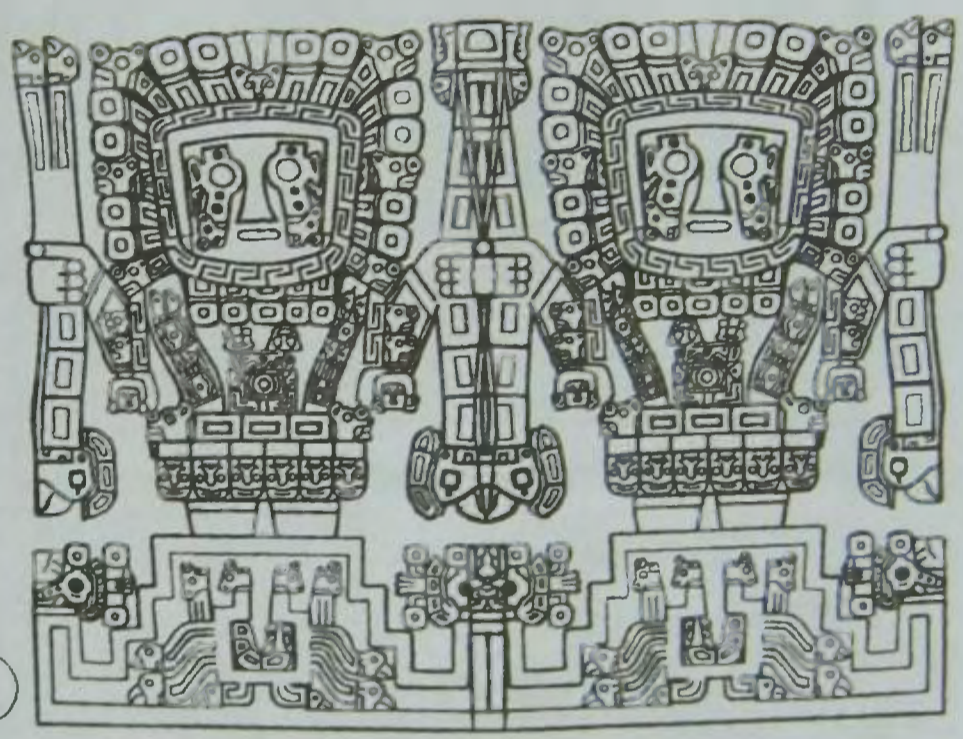
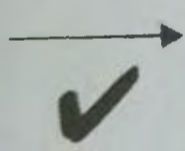
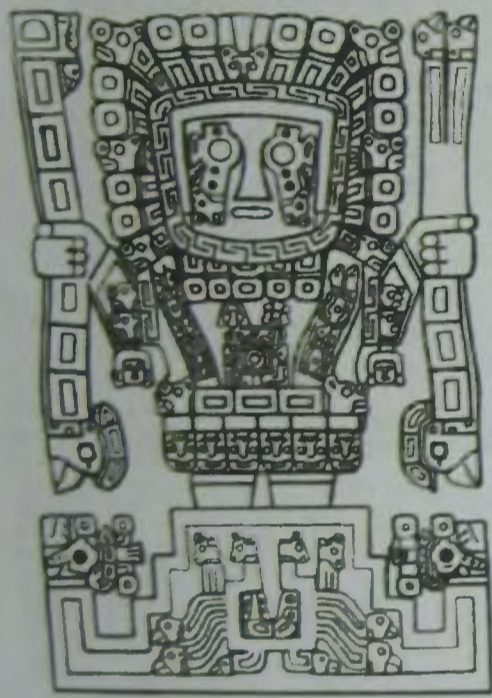
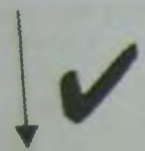

Figure A5 The top left-hand corner of the carving shows a semicircle (one *half* circle). The front side of the gateway also carries 48 other carvings [of Xipe Totec, Lord of the Stags]. These clues are in themselves astronomically insignificant. However, we note that there are 96 microcycles of magnetic activity in one *whole* sunspot cycle (figure A11). This suggests that half of the available information may be missing. By making a transparent facsimile of the Viracocha carving, the available information is doubled and now becomes astronomically significant (there are two semicircles in one Sun, and $2 \times 48 = 96$ microcycles of magnetic activity in one sunspot cycle). The first step in the decoding process is to overlay one half semicircle on its transparent facsimile, as shown in (b), above. However, this Peruvian 'Transformer', unlike the Maya Transformers, contains a built-in 'decoding inhibitor'. Attempts to decode the carving in this condition are defeated because the black areas obscure the underlying line patterns, as in (b). We note, from (a) that creatures with a long body and the profile of a bird's head hang upside-down from each of the hands of Viracocha. The body of each contains rectangles. Some of the rectangles are filled with black, others filled with white. This is an instruction which tells us to convert the black solid areas of the bas relief carving into a line-drawing: 'turn the black rectangles into white rectangles', as in (c). Now when we attempt to decode the Transformer by overlaying the two semicircles, as in (d), a composite design appears which shows that Viracocha is, like Lord Pacal of Mexico and Tutankhamun of Egypt, the feathered snake (Appendix 3).



(a) (b)



(c) (d)

Figure A5. The top left-hand corner of the carving shows a semicircle (one *half* circle). The front side of the gateway also carries 48 other carvings [of Xipe Totec, Lord of the Stags]. These clues are in themselves astronomically insignificant. However, we note that there are 96 microcycles of magnetic activity in one *whole* sunspot cycle (figure A11). This suggests that half of the available information may be missing. By making a transparent facsimile of the Viracocha carving, the available information is doubled and now becomes astronomically significant (there are two semicircles in one Sun, and $2 \times 48 = 96$ microcycles of magnetic activity in one sunspot cycle). The first step in the decoding process is to overlay one half semicircle on its transparent facsimile, as shown in (b), above. However, this Peruvian 'Transformer', unlike the Maya Transformers, contains a built-in 'decoding inhibitor'. Attempts to decode the carving in this condition are defeated because the black areas obscure the underlying line patterns, as in (b). We note, from (a) that creatures with a long body and the profile of a bird's head hang upside-down from each of the hands of Viracocha. The body of each contains rectangles. Some of the rectangles are infilled with black, others infilled with white. This is an instruction which tells us to convert the black solid areas of the bas relief carving into a line-drawing; 'turn the black rectangles into white rectangles', as in (c). Now when we attempt to decode the Transformer by overlaying the two semicircles, as in (d), a composite design appears which shows that Viracocha is, like Lord Pacal of Mexico and Tutankhamun of Egypt, the feathered snake (Appendix 3).

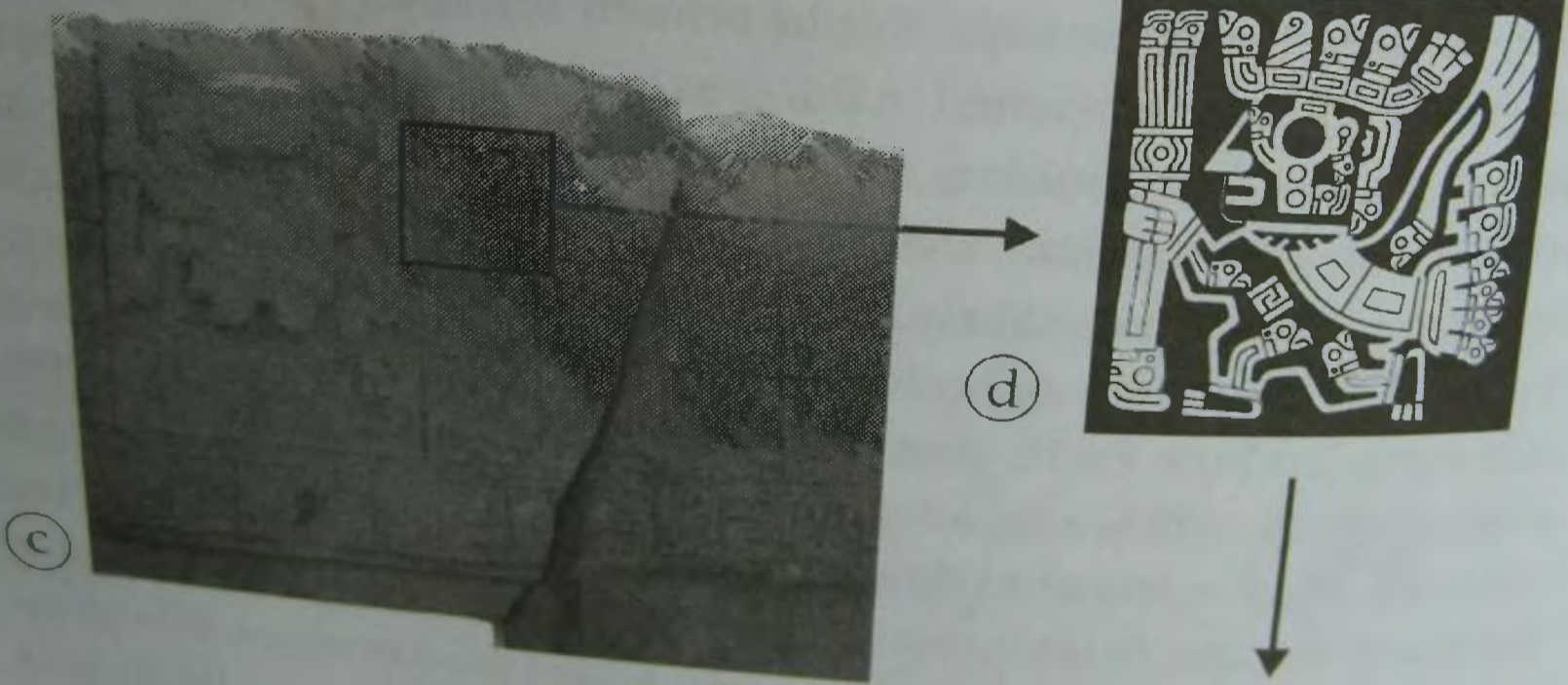
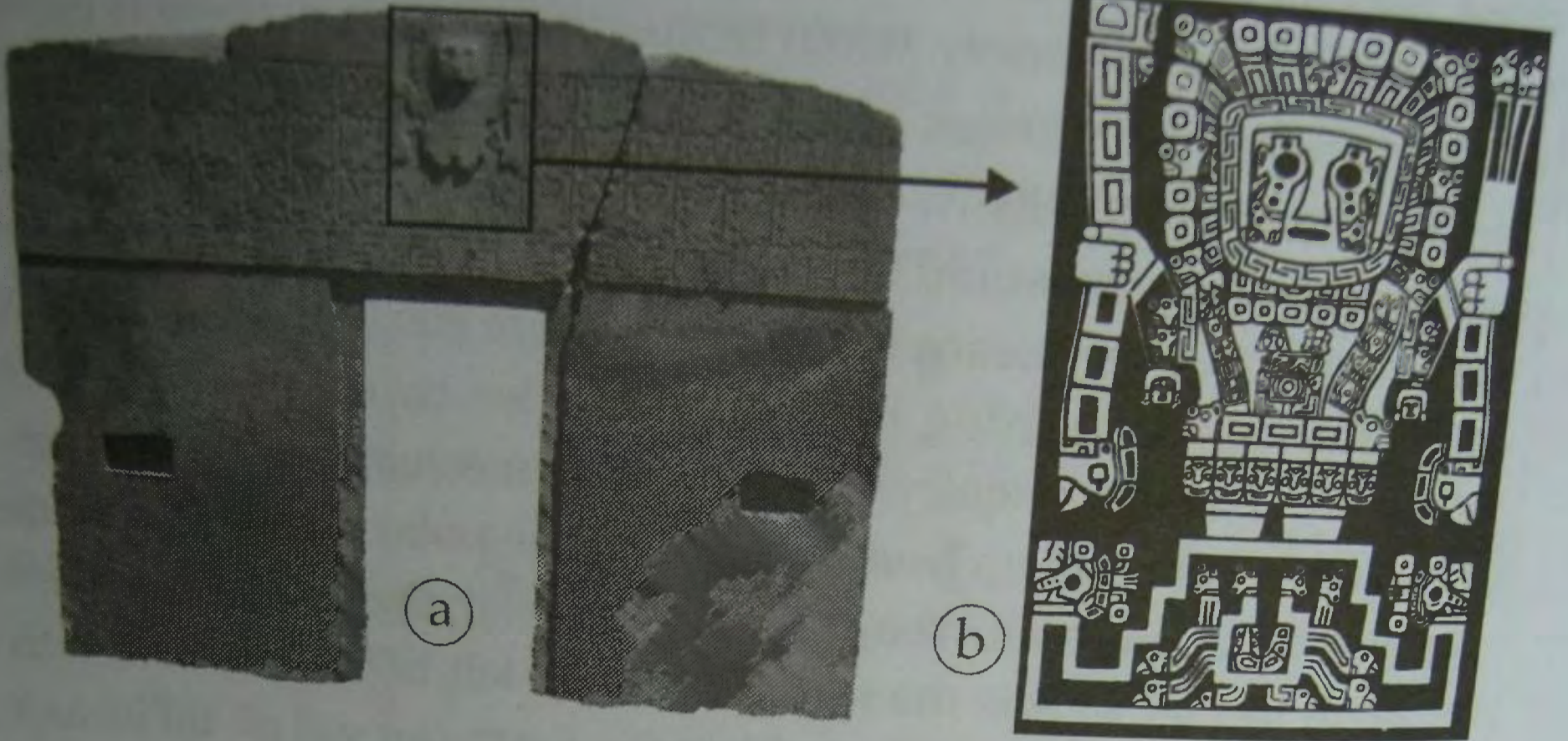

Finger A4. (a) Front (east-facing wall) of the Gateway of the Sun (in-situ) that today stands in the north-west corner of the Kalasasaya. (b) Viracocha bas relief carving on the lintel. (c) Xipe Totec bas relief from the lintel. (d) Line-drawing of (c). Picture of Xipe Totec, Maya Lord of the Stags, the God of Sacrifice, Hunting, Fire and Rebirth, from the Maya *Borbónico Codex* 14. [Cernunnos was Lord of the Stags for the Celts]

Cracking the Code of the Viracocha Transformer (I)

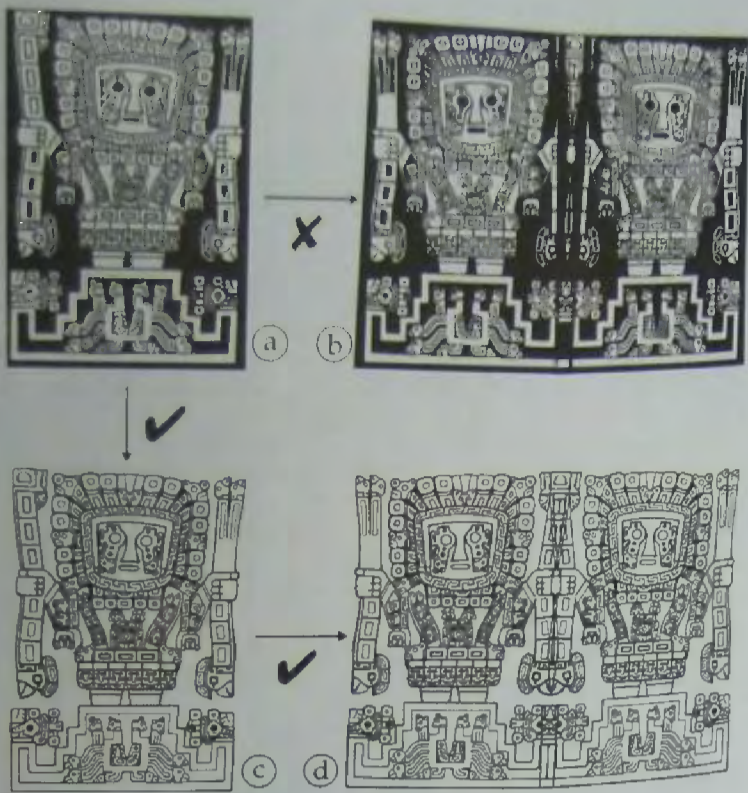

Figure A5. The top left-hand corner of the carving shows a semicircle (one half circle). The front side of the gateway also carries 48 other carvings [of Xipe Totec, Lord of the Stags]. These clues are in themselves astronomically insignificant. However, we note that there are 96 microcycles of magnetic activity in one whole sunspot cycle (figure A11). This suggests that half of the available information may be missing. By making a transparent facsimile of the Viracocha carving, the available information is doubled and now becomes astronomically significant (there are two semicircles in one Sun, and $2 \times 48 = 96$ microcycles of magnetic activity in one sunspot cycle). The first step in the decoding process is to overlay one half semicircle on its transparent facsimile, as shown in (b), above. However, this Peruvian 'transformer', unlike the Maya transformers, contains a built-in 'decoding inhibitor'. Attempts to decode the carving in this condition are defeated because the black areas obscure the underlying line patterns, as in (b). We note from (a) that creatures with a long body and the profile of a bird's head hang upside down from each of the hands of Viracocha. The body of each contains rectangles. Some of the rectangles are in-filled with black, others in-filled with white. This is an instruction which tells us to convert the black solid areas of the bas-relief carving into a line drawing, 'turn the black rectangles into white rectangles', as in (c). Now when we attempt to decode the transformer by overlaying the two semicircles, as in (d), a composite design appears which shows that Viracocha is, like Lord Pacal of Mexico and Tutankhamun of Egypt, the feathered snake (appendix 3).

Cracking the Code of the Viracocha Transformer (II)

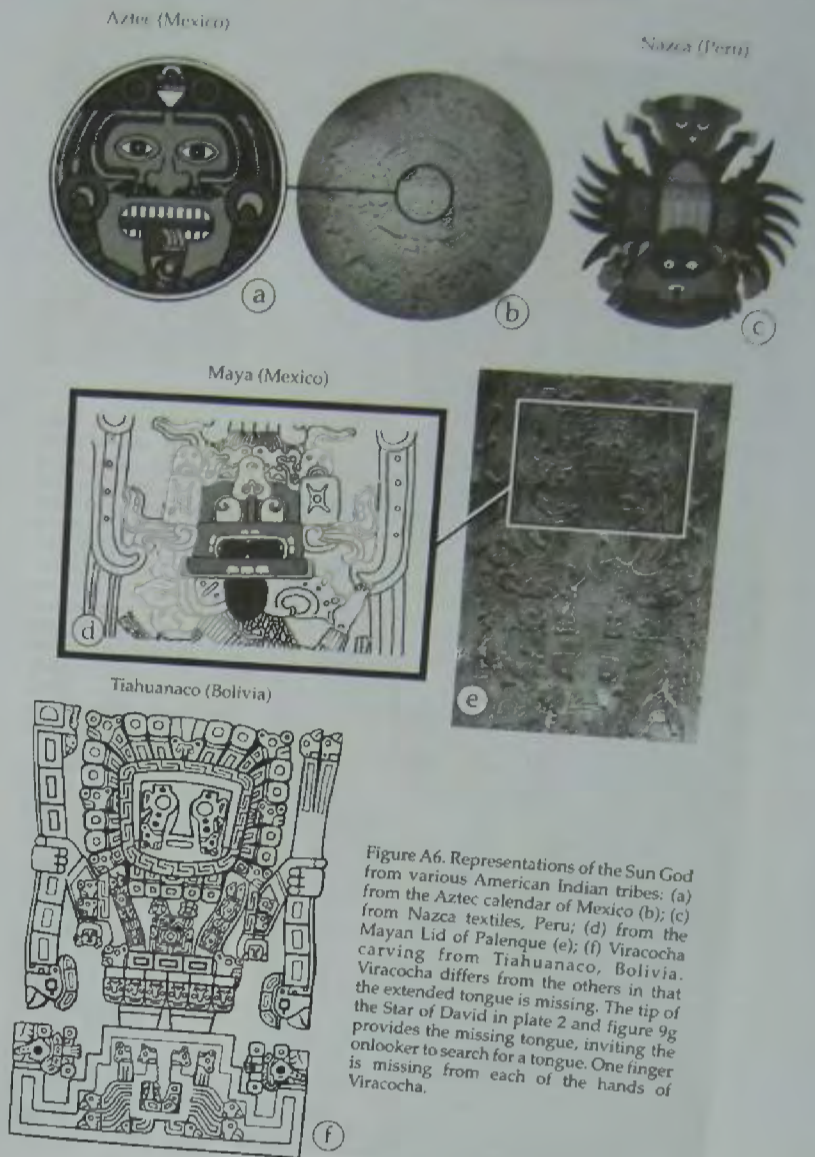

Figure A6. Representations of the Sun God from various American Indian tribes: (a) from the Aztec calendar of Mexico (b); (c) from Nazca textiles, Peru; (d) from the Maya Lid of Palenque (e); (f) Viracocha carving from Tiahuanaco, Bolivia. Viracocha differs from the others in that the extended tongue is missing. The tip of the Star of David in plate 2 and figure 9g provides the missing tongue, inviting the onlooker to search for a tongue. One finger is missing from each of the hands of Viracocha.

THE CELTIC CHRONICLES

Gateway of the Sun, Tiahuanaco, Bolivia

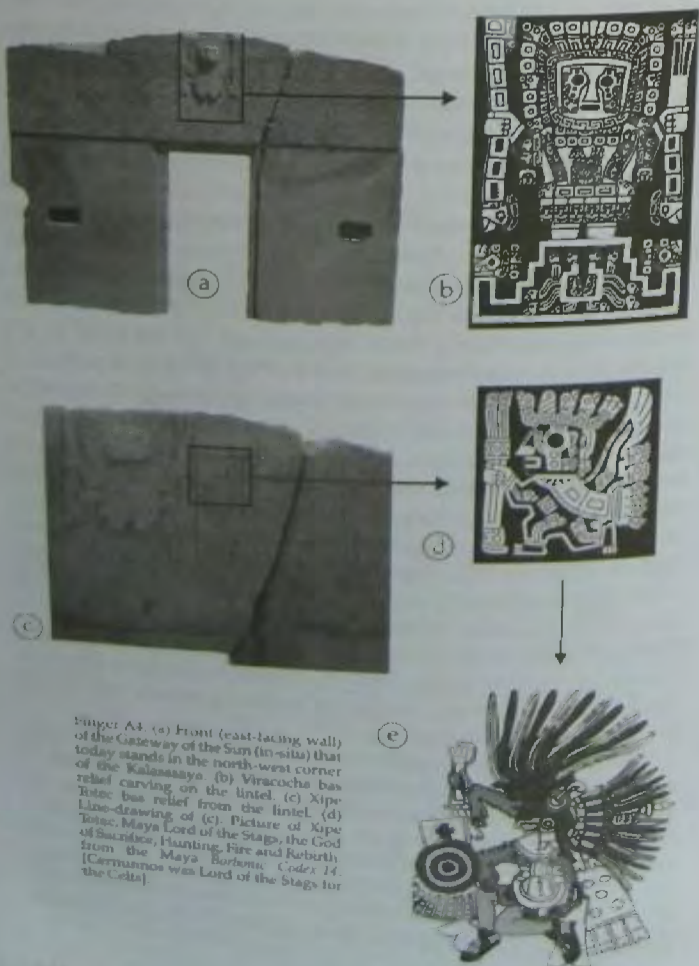

Figure A4. (a) Front (east-facing wall) of the Gateway of the Sun (in-situ) that today stands in the north-west corner of the Kalassaya. (b) Viracocha bas-relief carving on the lintel. (c) Xipe Totec bas-relief from the lintel. (d) Line-drawing of (c). (e) Picture of Xipe Totec, Maya Lord of the Stags, the God of Saucres, Hunting, Fire and Rebirth (Carmusno was Lord of the Stags for the Celts).

APPENDIX ONE

Cracking the Code of the Viracocha Transformer (I)

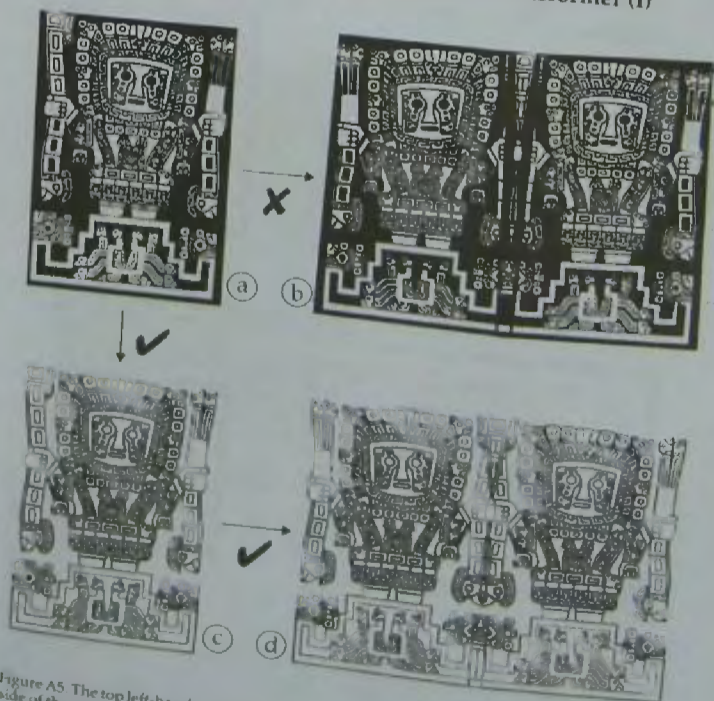

Figure A5. The top left-hand corner of the carving shows a semicircle (one half circle). The front side of the gateway also carries 48 other carvings [of Xipe Totec, Lord of the Stags]. These clues are in themselves astronomically insignificant. However, we note that there are 96 microcycles of magnetic activity in one whole sunspot cycle (figure A11). This suggests that half of the available information may be missing. By making a transparent facsimile of the Viracocha carving, the available information is doubled and now becomes astronomically significant (there are two semicircles in one Sun, and $2 \times 48 = 96$ microcycles of magnetic activity in one sunspot cycle). The first step in the decoding process is to overlay one half semicircle on its transparent facsimile, as shown in (b), above. However, this Peruvian 'transformer', unlike the Maya transformers, contains a built-in 'decoding inhibitor'. Attempts to decode the carving in this condition are defeated because the black areas obscure the underlying line patterns, as in (b). We note from (a) that creatures with a long body and the profile of a bird's head hang upside-down from each of the hands of Viracocha. The body of each contains rectangles. Some of the rectangles are in-filled with black, others in-filled with white. This is an instruction which tells us to convert the black solid areas of the bas-relief carving into a line drawing, 'turn the black rectangles into white rectangles', as in (c). Now when we attempt to decode the Transformer by overlaying the two semicircles, as in (d), a composite design appears which shows that Viracocha is, like Lord Pacal of Mexico and Tutankhamun of Egypt, the feathered snake (Appendix 3).

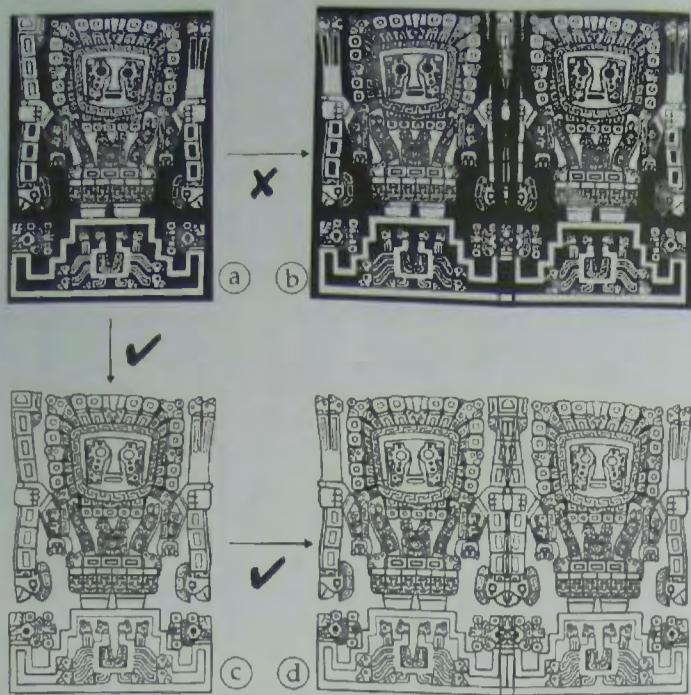

Figure A5. The top left-hand corner of the carving shows a semicircle (one half circle). The front side of the gateway also carries 48 other carvings [of Xipe Totec, Lord of the Stags]. These clues are in themselves astronomically insignificant. However, we note that there are 96 microcycles of magnetic activity in one whole sunspot cycle (figure A11). This suggests that half of the available information may be missing. By making a transparent facsimile of the Viracocha carving, the available information is doubled and now becomes astronomically significant (there are two semicircles in one Sun, and $2 \times 48 = 96$ microcycles of magnetic activity in one sunspot cycle). The first step in the decoding process is to overlay one half semicircle on its transparent facsimile, as shown in (b), above. However, this Peruvian 'transformer', unlike the Mayan transformers, contains a built-in 'decoding inhibitor'. Attempts to decode the carving in this condition are defeated because the black areas obscure the underlying line patterns, as in (b). We note from (a) that creatures with a long body and the profile of a bird's head hang upside down from each of the hands of Viracocha. The body of each contains rectangles. Some of the rectangles are in-filled with black, others in-filled with white. This is an instruction which tells us to convert the black solid areas of the bas-relief carving into a line drawing: 'turn the black rectangles into white rectangles', as in (c). Now when we attempt to decode the transformer by overlaying the two semicircles, as in (d), a composite design appears which shows that Viracocha is, like Lord Pacal of Mexico and Tutankhamun of Egypt, the feathered snake (appendix 3).



Figure A6. Representations of the Sun God from various American Indian tribes: (a) from the Aztec calendar of Mexico (b); (c) from Nazca textiles, Peru; (d) from the Mayan Lid of Palenque (e); (f) Viracocha carving from Tiahuanaco, Bolivia. Viracocha differs from the others in that the extended tongue is missing. The tip of the Star of David in plate 2 and figure 9g provides the missing tongue, inviting the onlooker to search for a tongue. One finger is missing from each of the hands of Viracocha.

Cracking the code of the Viracocha Transformer (II)

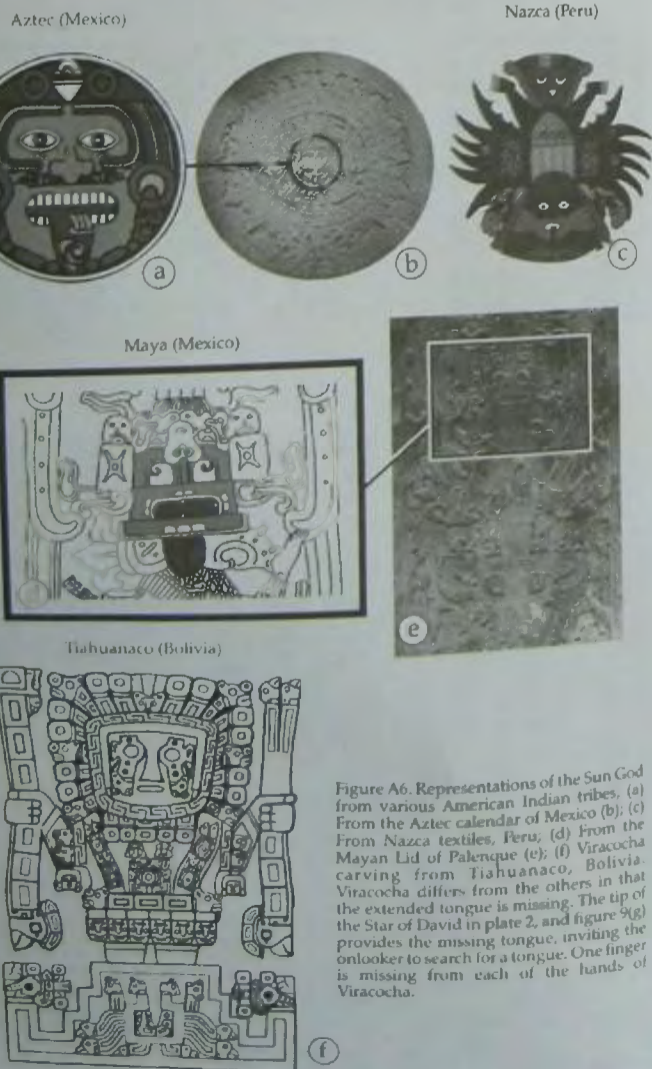

Figure A6. Representations of the Sun God from various American Indian tribes: (a) From the Aztec calendar of Mexico (b); (c) From Nazca textiles, Peru; (d) From the Mayan Lid of Palenque (e); (f) Viracocha carving from Tiahuanaco, Bolivia. Viracocha differs from the others in that the extended tongue is missing. The tip of the Star of David in plate 2, and figure 9g provides the missing tongue, inviting the onlooker to search for a tongue. One finger is missing from each of the hands of Viracocha.

Cracking the Code of the Viracocha Transformer (III);
The Secrets of the Viracocha Statue



Figure A7. Statues from Tiahuanaco conceal secret instructions. The facial markings of this one from the Kalasasaya are similar to those on the Viracocha carving found on the Gateway of the Sun, suggesting that this statue is another representation of Viracocha. However, we note that the hands of the Viracocha statue correctly carry five fingers, unlike the Viracocha carving on the Gateway of the Sun which has one finger missing from each hand; (i) the Viracocha statue carries a figure of a male in his right hand and a figure of a female (ii), figure of a female, upside-down, in his left. This tells us to, firstly, make an image (male) of Viracocha (the Viracocha transformer from the Gateway of the Sun) then make another image, this time the (opposite), mirror image (female). Finally, we are instructed to turn the mirror image (female) upside down. When these instructions are followed another secret message is revealed (figure A8).

Cracking the Code of the Viracocha Transformer (II)

Aztec (Mexico)



(a)

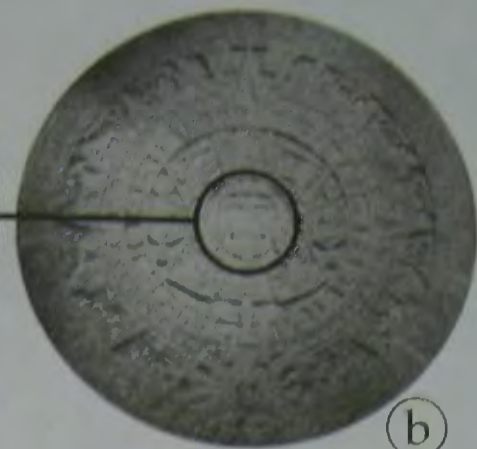

(b)

Nazca (Peru)



(c)

Maya (Mexico)



(d)

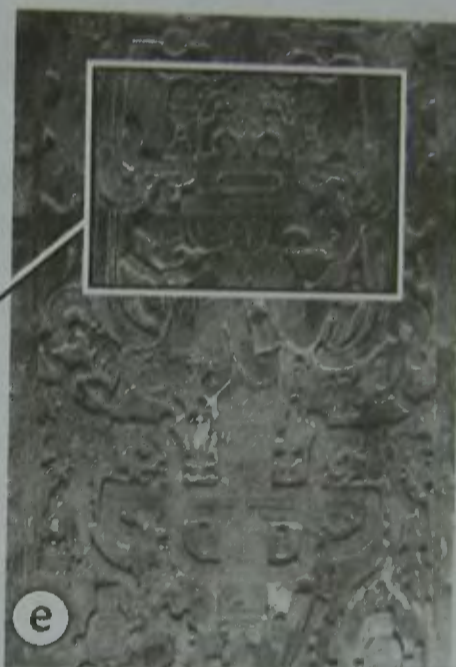

(e)

Tiahuanaco (Bolivia)

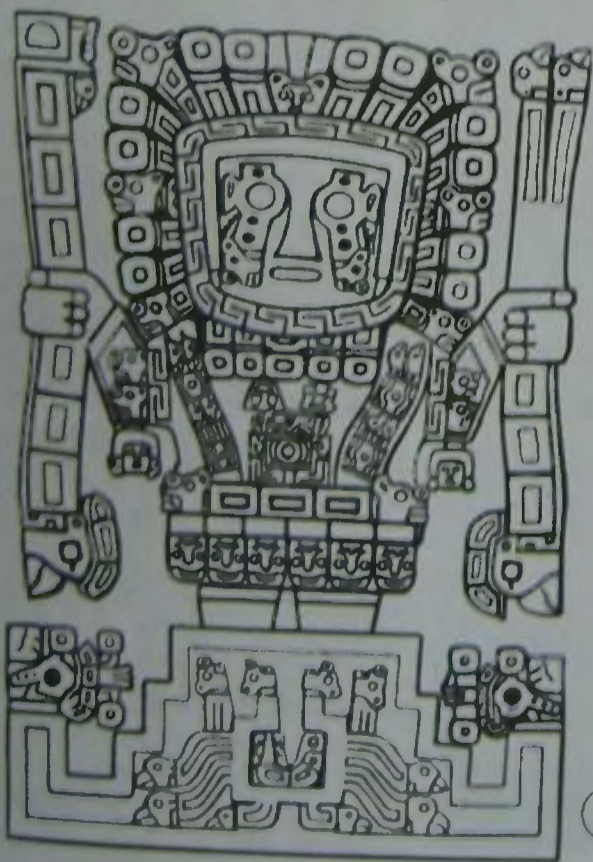

(f)

Figure A6. Representations of the Sun God from various American Indian tribes: (a) from the Aztec calendar of Mexico (b); (c) from Nazca textiles, Peru; (d) from the Mayan Lid of Palenque (e); (f) Viracocha carving from Tiahuanaco, Bolivia. Viracocha differs from the others in that the extended tongue is missing. The tip of the Star of David in plate 2 and figure 9g provides the missing tongue, inviting the onlooker to search for a tongue. One finger is missing from each of the hands of Viracocha.

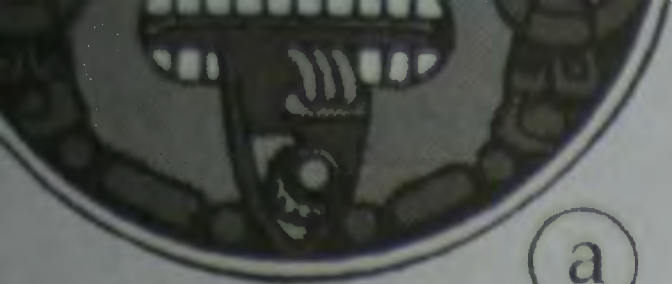

(a)



(b)



Maya (Mexico)



(d)

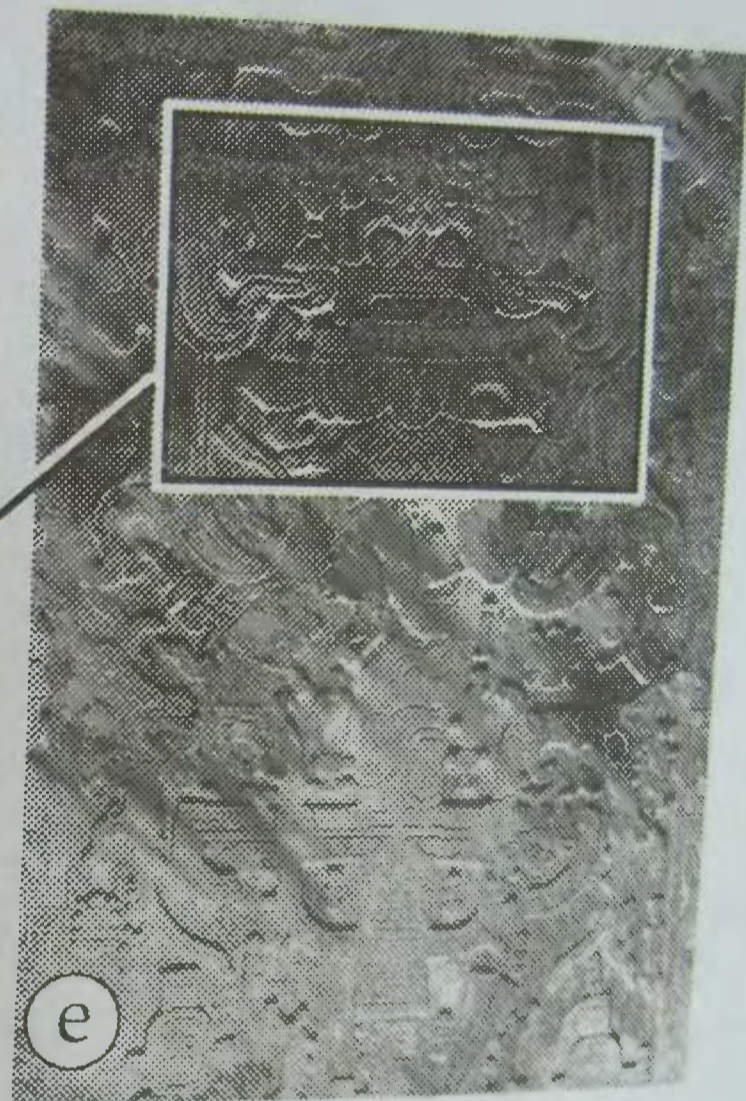

(e)

Tiahuanaco (Bolivia)

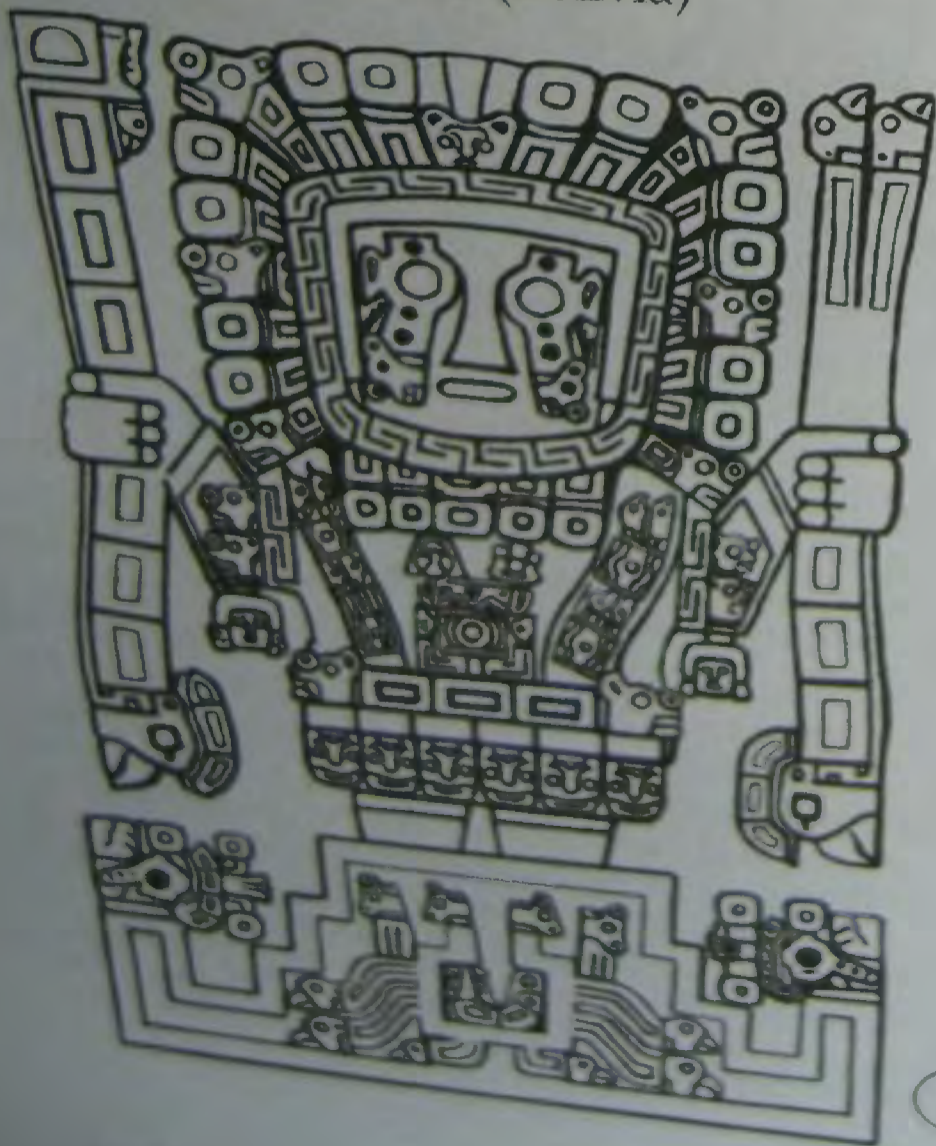

(f)

Figure A6. Representations of the Sun God from various American Indian tribes; (a) From the Aztec calendar of Mexico (b); (c) From Nazca textiles, Peru; (d) From the Mayan Lid of Palenque (e); (f) Viracocha carving from Tiahuanaco, Bolivia. Viracocha differs from the others in that the extended tongue is missing. The tip of the Star of David in plate 2, and figure 9(g) provides the missing tongue, inviting the onlooker to search for a tongue. One finger is missing from each of the hands of Viracocha.

Cracking the Code of the Viracocha Transformer (IV)

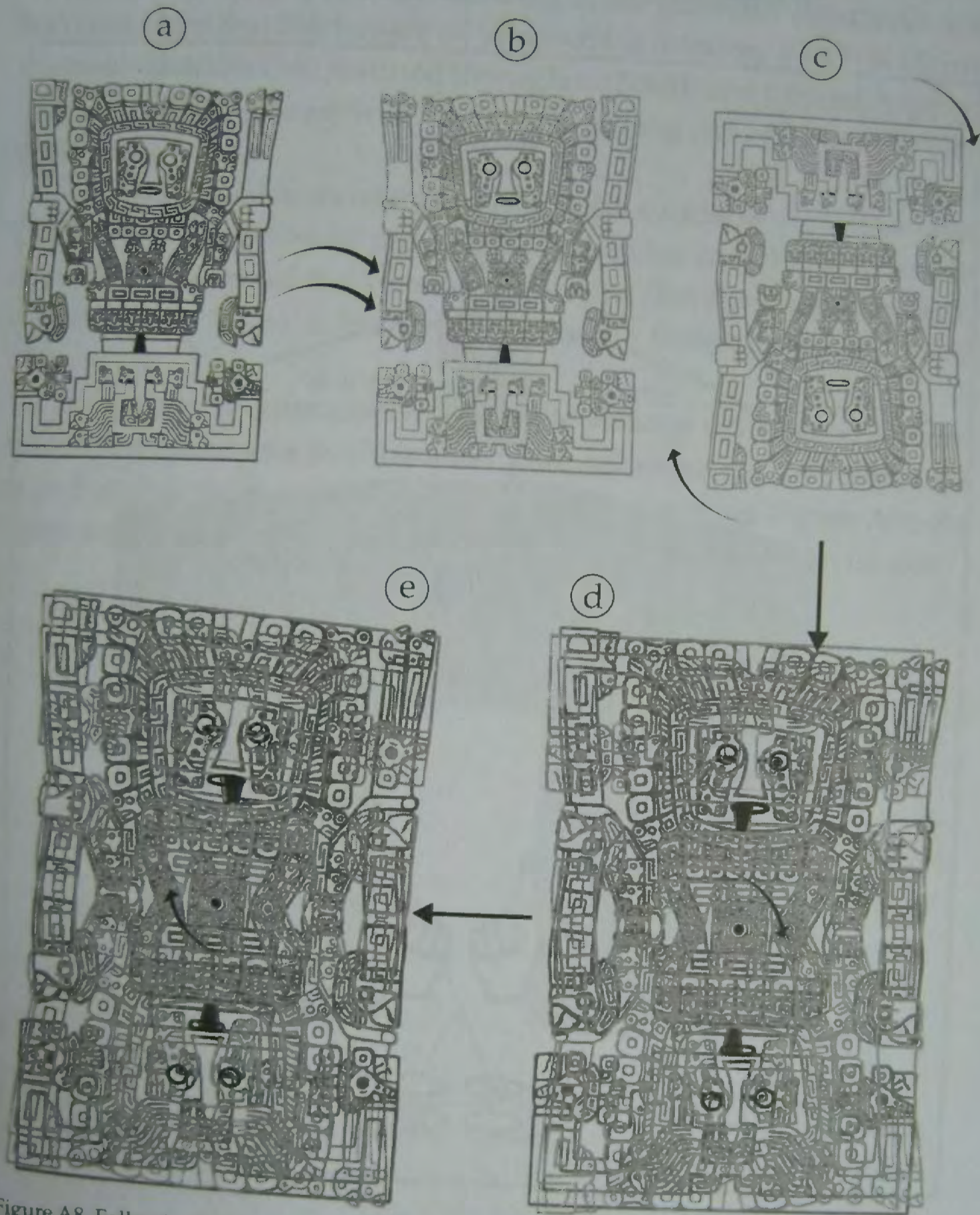

Figure A8. Following the instructions given by figure A7: (a) make an image of Viracocha (male); (b) make another image, the opposite of the Viracocha image (female); (c) turn the second image (female) upside down. Now, by using the Mayan transformer decoding process, the two images are overlaid (d). The missing tongue from the Viracocha bas-relief is now restored (located). Rotating the transparencies back and forth (d) and (e) about the epicentre (the circle located in the centre of the composite arrangement), the tongue of Viracocha waggles alternately from left to right. At the same time Viracocha closes each eye alternately. We again note that the Viracocha carving has one finger from each hand missing. The message here is that the observer should stand behind the doorway of the Gateway of the Sun raising one finger of each hand so that one finger frames either side of the doorway (figure A9). The angle of the Sun can now be measured through the doorway using parallax error derived by alternately opening and closing each eye.



Figure A7. Statues from Tiahuanaco conceal secret instructions. The facial markings of this one from the Kalasasaya are similar to those on the Viracocha carving found on the Gateway of the Sun, suggesting that this statue is another representation of Viracocha. However, we note that the hands of the Viracocha statue correctly carry five fingers, unlike the Viracocha carving on the Gateway of the Sun, which has one finger missing from each hand. (i) The Viracocha statue carries a figure of a male in his right hand and a figure of a female (ii) upside down, in his left. This tells us to, firstly, *make an image (male) of Viracocha (the Viracocha transformer from the Gateway of the Sun), then make another image, this time the (opposite), mirror image (female)*. Finally, we are instructed to *turn the mirror image (female) upside down*. When these instructions are followed, another secret message is revealed (figure A8).

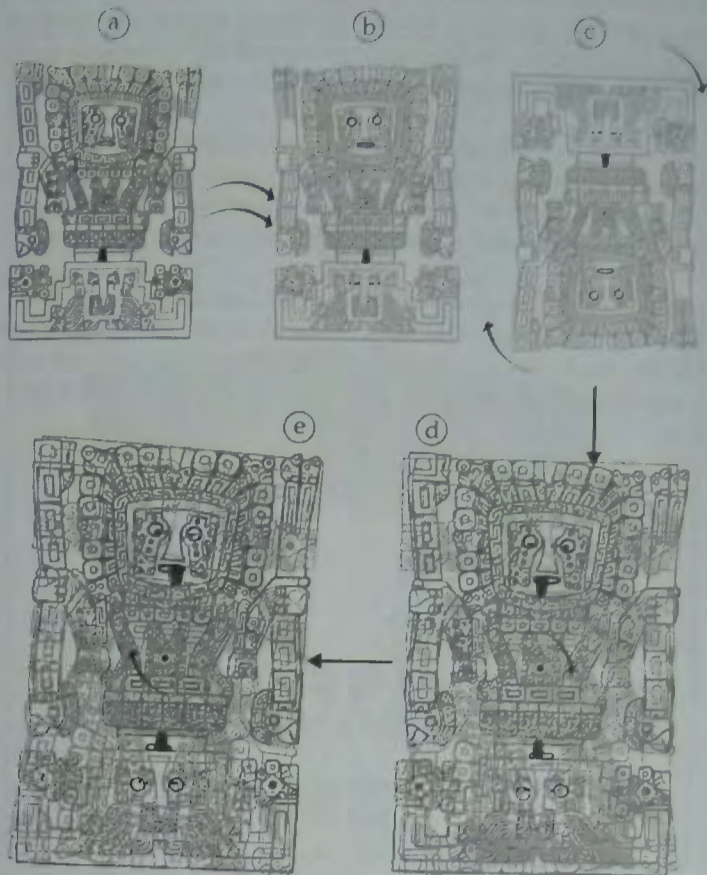

Figure A8. Following the instructions given by figure A7: (a) *make an image of Viracocha (male)*; (b) *make another image, the opposite of the Viracocha image (female)*; (c) *turn the second image (female) upside down*. Now, by using the Mayan transformer decoding process, the two images are overlaid (d). The missing tongue from the Viracocha bas-relief is now restored (located). Rotating the transparencies back and forth (d) and (e) about the epicentre (the circle located in the centre of the composite arrangement), the tongue of Viracocha waggles alternately from left to right. At the same time Viracocha closes each eye alternately. We again note that the Viracocha carving has one finger from each hand missing. The message here is that the observer should stand behind the doorway of the Gateway of the Sun raising one finger of each hand so that one finger frames either side of the doorway (figure A9). The angle of the Sun can now be measured through the doorway using parallax error derived by alternately opening and closing each eye.

Cracking the code of the Viracocha Transformer (II)

Aztec (Mexico)



(a)

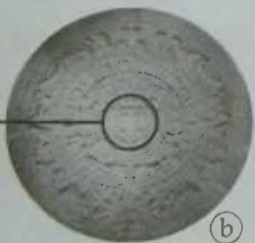

(b)

Nazca (Peru)



(c)

Maya (Mexico)



(e)

Tiahuanaco (Bolivia)

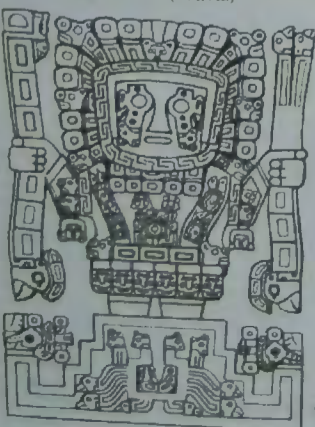

(f)

Figure A6. Representations of the Sun God from various American Indian tribes; (a) From the Aztec calendar of Mexico (b); (c) From Nazca textiles, Peru; (d) From the Mayan Lid of Palenque (e); (f) Viracocha carving from Tiahuanaco, Bolivia. Viracocha differs from the others in that the extended tongue is missing. The tip of the Star of David in plate 2, and figure 9(g) provides the missing tongue, inviting the onlooker to search for a tongue. One finger is missing from each of the hands of Viracocha.

Cracking the Code of the Viracocha Transformer (III):
The Secrets of the Viracocha Statue

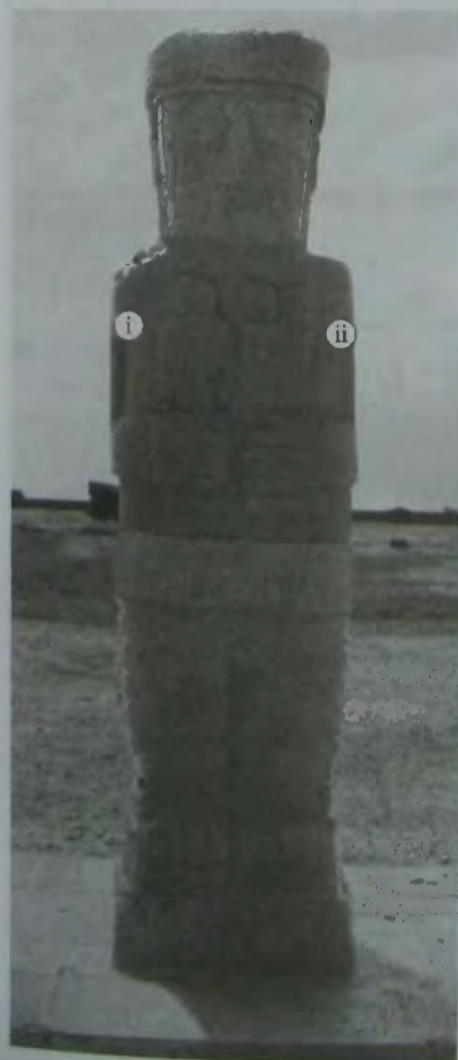

Figure A7. Statues from Tiahuanaco conceal secret instructions. The facial markings of this one from the Kalasasaya are similar to those on the Viracocha carving found on the Gateway of the Sun, suggesting that this statue is another representation of Viracocha. However, we note that the hands of the Viracocha statue correctly carry five fingers, unlike the Viracocha carving on the Gateway of the Sun which has one finger missing from each hand; (i) the Viracocha statue carries a figure of a male in his right hand and a figure of a female (ii), upside-down, in his left. This tells us to, firstly, *make an image (male) of Viracocha (the Viracocha transformer from the Gateway of the Sun) then make another image, this time the (opposite), mirror image (female)*. Finally, we are instructed to *turn the mirror image (female) upside down*. When these instructions are followed another secret message is revealed (figure A8).



Figure A7. Statues from Tiahuanaco conceal secret instructions. The facial markings of this one from the Kalasasaya are similar to those on the Viracocha carving found on the Gateway of the Sun, suggesting that this statue is another representation of Viracocha. However, we note that the hands of the Viracocha statue correctly carry five fingers, unlike the Viracocha carving on the Gateway of the Sun, which has one finger missing from each hand. (i) The Viracocha statue carries a figure of a male in his right hand and a figure of a female (ii) upside down, in his left. This tells us to, firstly, *make an image (male) of Viracocha (the Viracocha transformer from the Gateway of the Sun), then make another image, this time the (opposite), mirror image (female)*. Finally, we are instructed to *turn the mirror image (female) upside down*. When these instructions are followed, another secret message is revealed (figure A8).

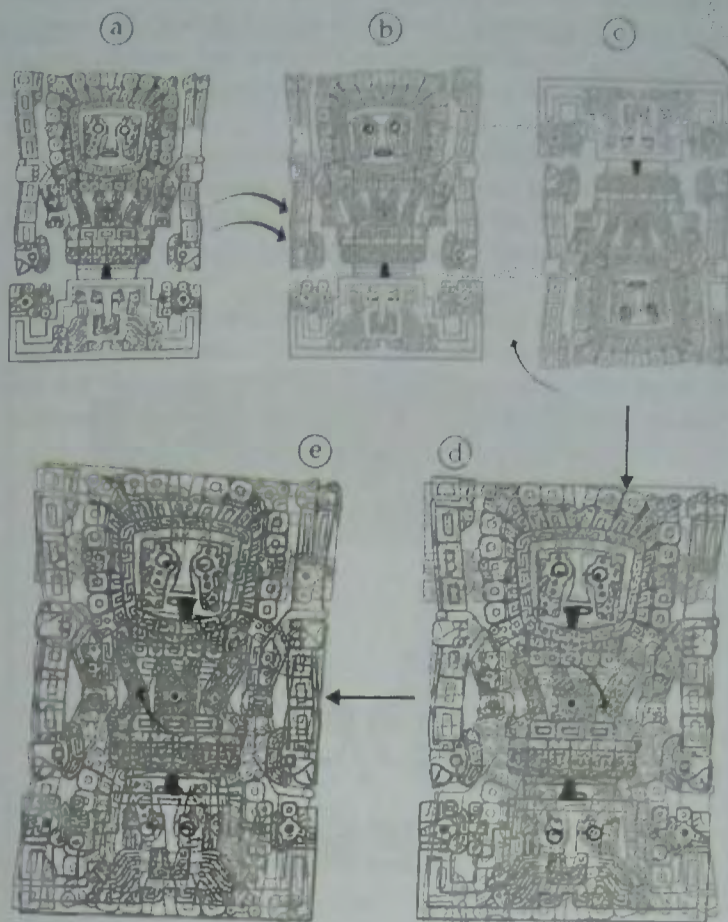

Figure A8. Following the instructions given by figure A7: (a) *make an image of Viracocha (male)*; (b) *make another image, the opposite of the Viracocha image (female) upside down*. Now, by using the Mayan transformer decoding process, the two images are overlaid (d). The missing tongue from the Viracocha bas-relief is now restored (located). Rotating the transparencies back and forth (d) and (e) about the epicentre (the circle located in the centre of the composite arrangement), the tongue of Viracocha waggles alternately from left to right. At the same time Viracocha closes each eye alternately. We again note that the Viracocha carving has one finger from each hand missing. The message here is that the observer should stand behind the doorway of the Gateway of the Sun raising one finger of each hand so that one finger frames either side of the doorway (figure A9). The angle of the Sun can now be measured through the doorway using parallax error derived by alternately opening and closing each eye.

Cracking the code of the Viracocha Transformer (II)

Aztec (Mexico)

Nazca (Peru)



Maya (Mexico)



Tiahuanaco (Bolivia)

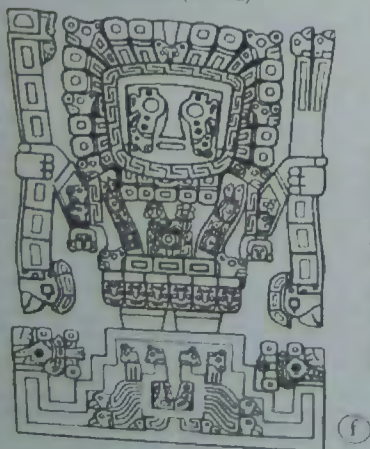

Figure A6. Representations of the Sun God from various American Indian tribes: (a) From the Aztec calendar of Mexico (b); (c) From Nazca textiles, Peru; (d) From the Mayan Lid of Palenque (e); (f) Viracocha carving from Tiahuanaco, Bolivia. Viracocha differs from the others in that the extended tongue is missing. The tip of the Star of David in plate 2, and figure 9(g) provides the missing tongue, inviting the onlooker to search for a tongue. One finger is missing from each of the hands of Viracocha.

Cracking the Code of the Viracocha Transformer (III);
The Secrets of the Viracocha Statue

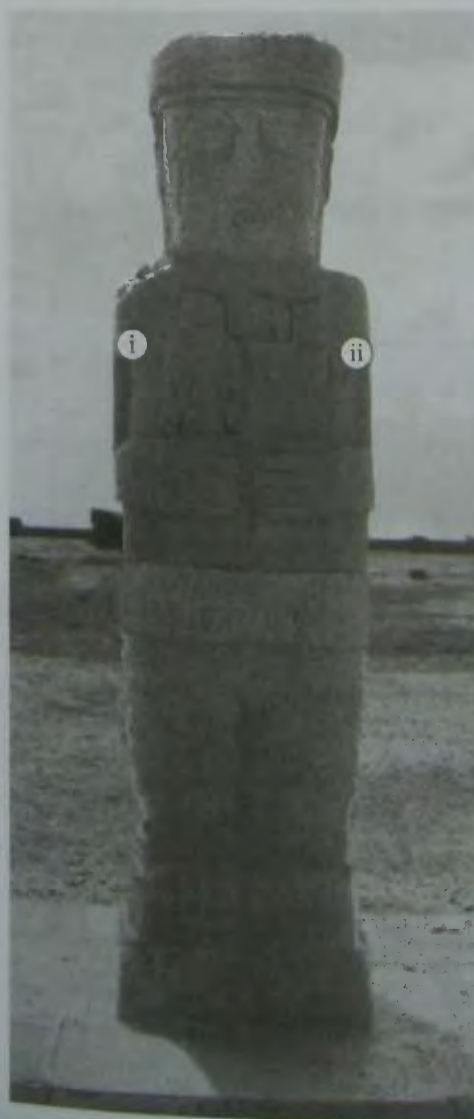

Figure A7. Statues from Tiahuanaco conceal secret instructions. The facial markings of this one from the Kalasasaya are similar to those on the Viracocha carving found on the Gateway of the Sun, suggesting that this statue is another representation of Viracocha. However, we note that the hands of the Viracocha statue correctly carry five fingers, unlike the Viracocha carving on the Gateway of the Sun which has one finger missing from each hand; (i) the Viracocha statue carries a figure of a male in his right hand and a figure of a female (ii) upside-down, in his left. This tells us to, firstly, *make an image (male) of Viracocha (the Viracocha transformer from the Gateway of the Sun) then make another image, this time the (opposite), mirror image (female)*. Finally, we are instructed to *turn the mirror image (female) upside down*. When these instructions are followed another secret message is revealed (figure A8).

Decoding the Viracocha Transformer (V)

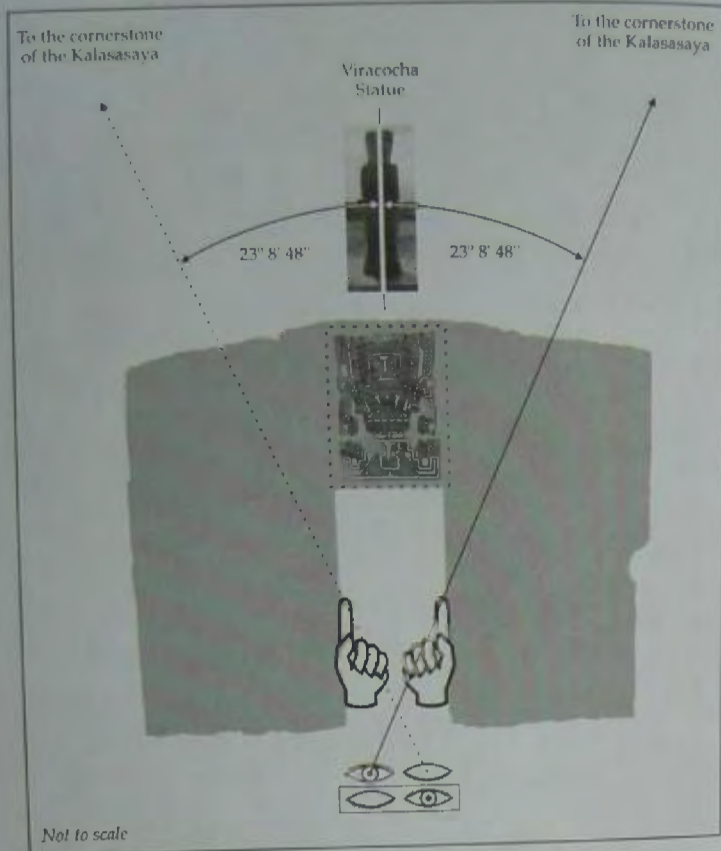

Figure A9. The Viracocha Transformer, when decoded, calls for the observer to stand behind the Gateway of the Sun in the Kalasasaya at Tiahuanaco. The lateral angle from the centre of the gateway to each of the cornerstones of the Kalasasaya can then be measured using parallax error derived from alternately opening and closing each eye (measured against raised index fingers) as shown above. This is the reason the Viracocha Transformer carries only three fingers and a thumb—the message being 'using one finger from each hand...'. The measured angle of $23^{\circ} 8' 48''$ corresponds to the tilt of the Earth on its axis at the time Tiahuanaco was built. This angle varies from the tilt of the Earth, measured as $23^{\circ} 27'$ in 1930. In 1914 Professor Arthur Posnansky believed that the Kalasasaya contained astronomical alignments and obtained the same information using surveying instruments. He proposed consequently that Tiahuanaco dated as far back as 15,000 BC.

Looking more closely at a line drawing of the bas-relief (figure A5c), it becomes clear that the tongue of Viracocha is missing, which is highly unusual. The Sun God featured throughout South and Central America is almost always shown with his tongue poking out of his mouth (figure A6a-e).

The statue of Viracocha that stands in the middle of the Kalasasaya, just beyond the gateway, provides the next clue in helping to understand the meaning of the Viracocha bas-relief line drawing. The statue carries a male figure in his right hand and a female figure in his left (figure A7).

Following the instructions leads us to arrange the Viracocha transformer transparencies as shown in figure A8, revealing the secret message that Viracocha encoded into his bas-relief carving (figure A9): the Earth was destroyed on previous occasions when it tilted on its axis.

THE CELTIC CHRONICLES

Cracking the Code of the Viracocha Transformer (IV)

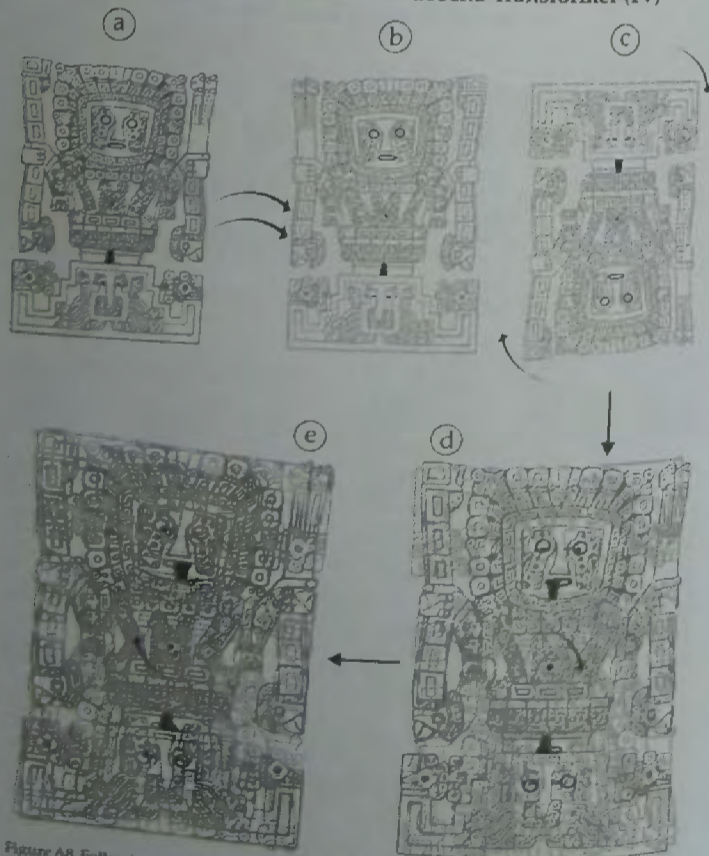

Figure A8. Following the instructions given by figure A7, (a) make an image of Viracocha (male); (b) make another image, the opposite of the Viracocha image (female); (c) turn the second image (female) upside-down. Now, by using the Maya Transformer decoding process, (d) the missing tongue from the Viracocha bas relief is now restored (located to the centre of the composite arrangement) the tongue of Viracocha waggles alternately from left to right. At the same time Viracocha closes each eye alternately. We again note that the observer should stand behind the doorway of the Gateway of the Sun raising one finger of each hand so that one finger frames either side of the doorway (figure A9). The angle of the Sun can now be measured through the doorway using parallax error derived by alternately opening and closing each eye in turn.

APPENDIX ONE

Decoding the Viracocha Transformer (V)

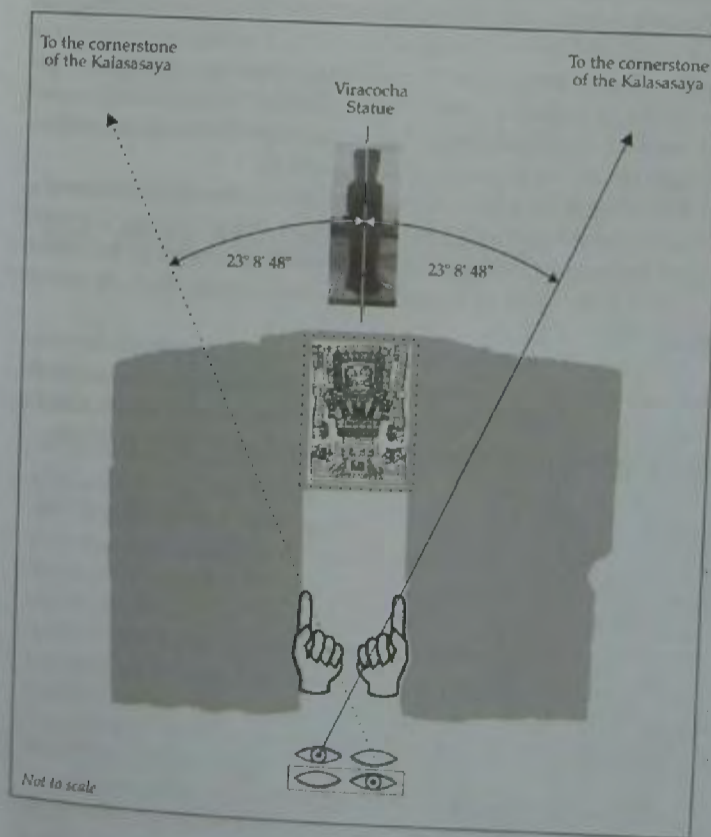

Figure A9. The Viracocha Transformer, when decoded, calls for the observer to stand behind the Gateway of the Sun in the Kalasasaya at Tiahuanaco. The lateral angle from the centre of the gateway to each of the cornerstones of the Kalasasaya can then be measured using parallax error derived from alternately opening and closing each eye (measured against raised index fingers) as shown above. This is the reason the Viracocha Transformer carries only three fingers and a thumb—the message being 'using one finger from each hand...'. The measured angle of $23^{\circ} 8' 48''$ corresponds to the tilt of the Earth on its axis at the time Tiahuanaco was built. This angle varies from the tilt of the Earth, measured as $23^{\circ} 27'$ in 1930. In 1914 Professor Arthur Posnansky believed that the Kalasasaya contained astronomical alignments and obtained the same information using surveying instruments. He proposed consequently that Tiahuanaco dated as far back as 15,000 BC.

Decoding the Viracocha Transformer (V)

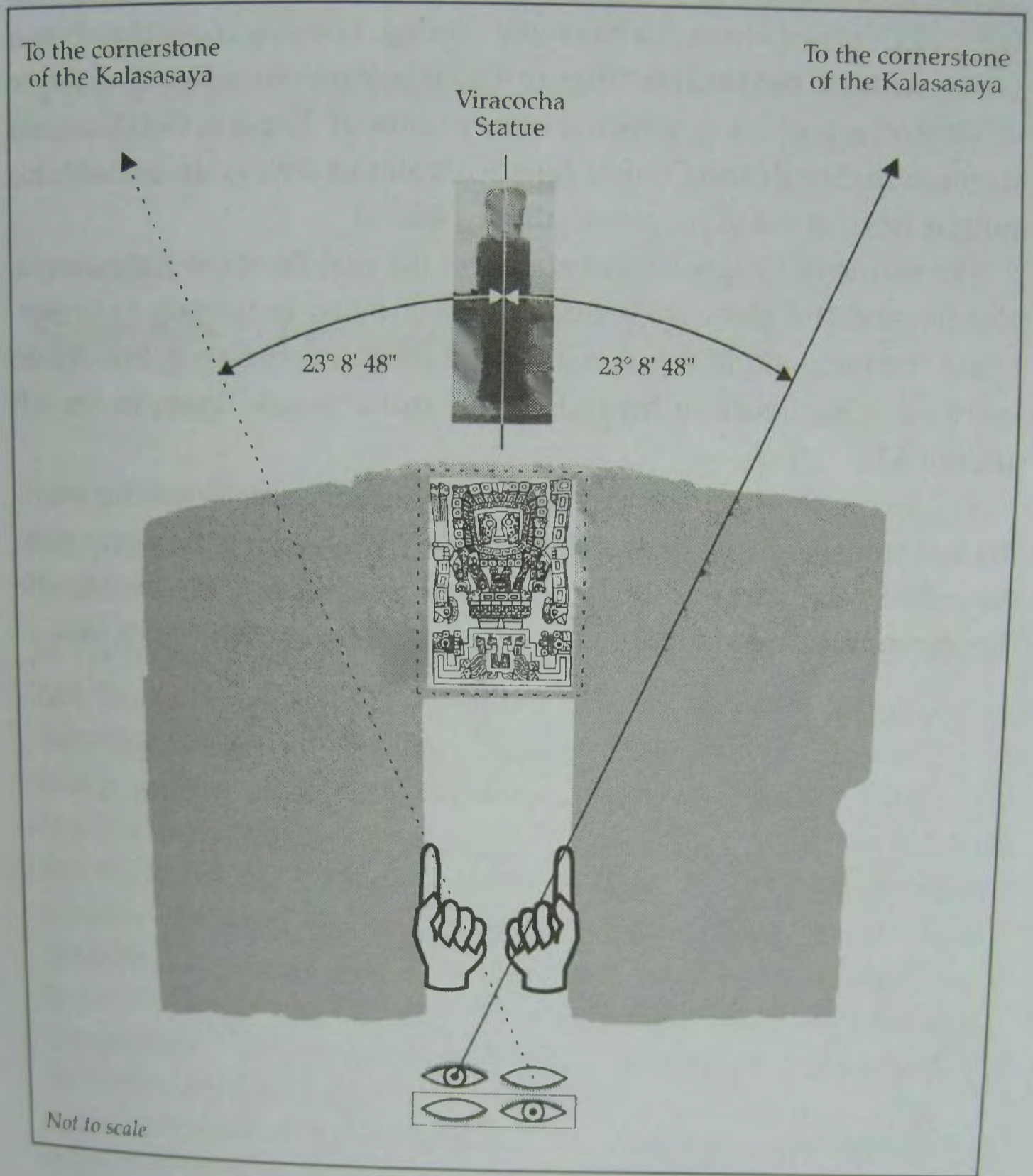

Figure A9. The Viracocha Transformer, when decoded, calls for the observer to stand behind the Gateway of the Sun in the Kalasasaya at Tiahuanaco. The lateral angle from the centre of the gateway to each of the cornerstones of the Kalasasaya can then be measured using parallax error derived from alternately opening and closing each eye (measured against raised index fingers) as shown above. This is the reason the Viracocha Transformer carries only three fingers and a thumb—the message being 'using one finger from each hand...'. The measured angle of 23° 8' 48" corresponds to the tilt of the Earth on its axis at the time Tiahuanaco was built. This angle varies from the tilt of the Earth, measured as 23° 27' in 1930. In 1914 Professor Arthur Posnansky believed that the Kalasasaya contained astronomical alignments and obtained the same information using surveying instruments. He proposed consequently that Tiahuanaco dated as far back as 15000 BC.

Cracking the Code of the Viracocha Transformer (IV)

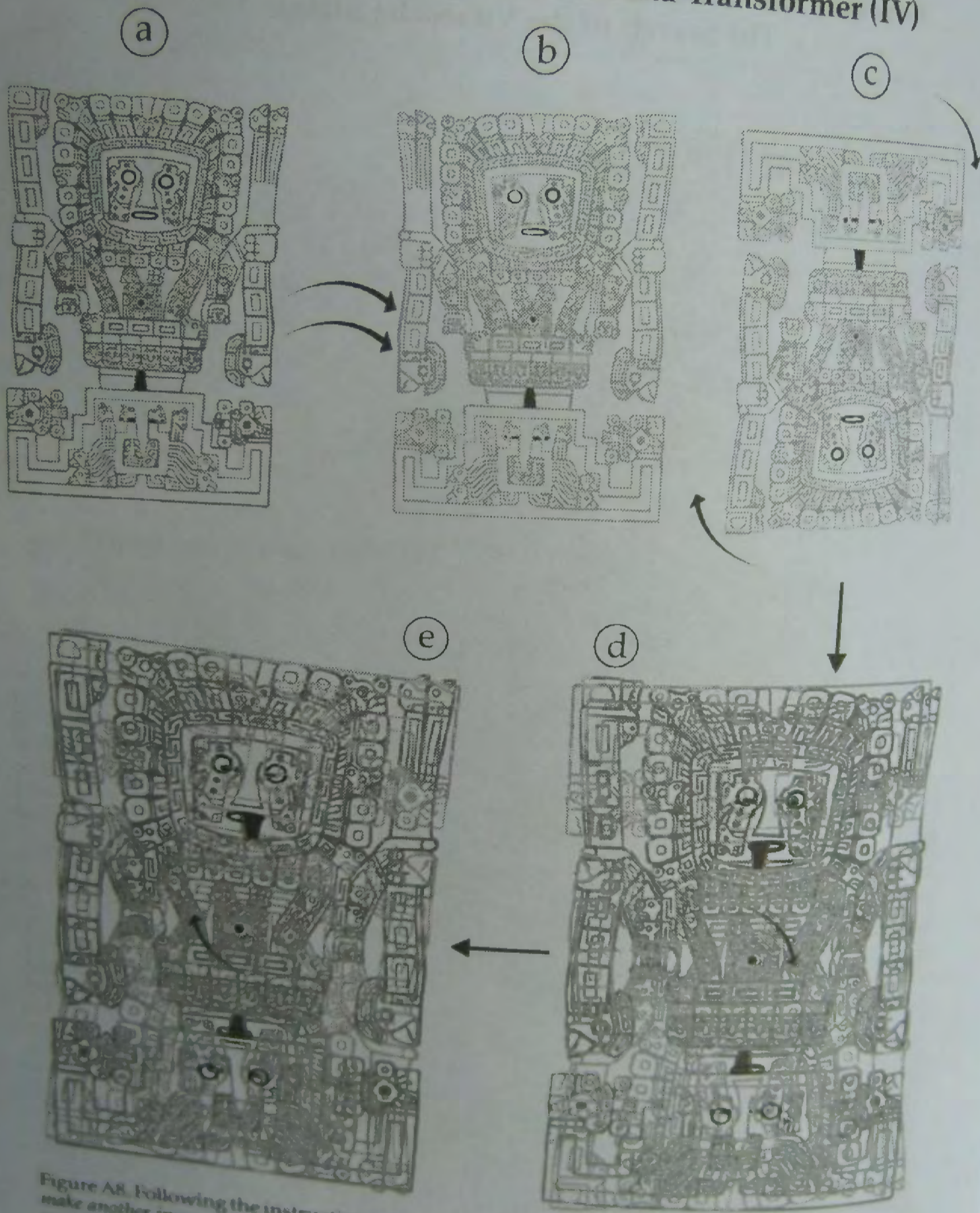

Figure A8. Following the instructions given by figure A7; (a) make an image of Viracocha (male); (b) make another image, the opposite of the Viracocha image (female); (c) turn the second image (female) upside-down. Now, by using the Maya Transformer decoding process, the two images are overlaid (d). The missing tongue from the Viracocha bas relief is now restored (located). Rotating the transparencies back and forth (d and e) about the epicentre (the circle located in the centre of the composite arrangement) the tongue of Viracocha waggles alternately from left to right. At the same time Viracocha closes each eye alternately. We again note that the Viracocha carving has one finger from each hand missing. The message here is that the observer should stand behind the doorway of the Gateway of the Sun raising one finger of each hand so that one finger frames either side of the doorway (figure A9). The angle of the Sun can now be measured through the doorway using parallax error derived by alternately opening and closing each eye in turn.

Figure
the C
gatev
error
finger
and a
48" co
varies
believ
inform
as far b

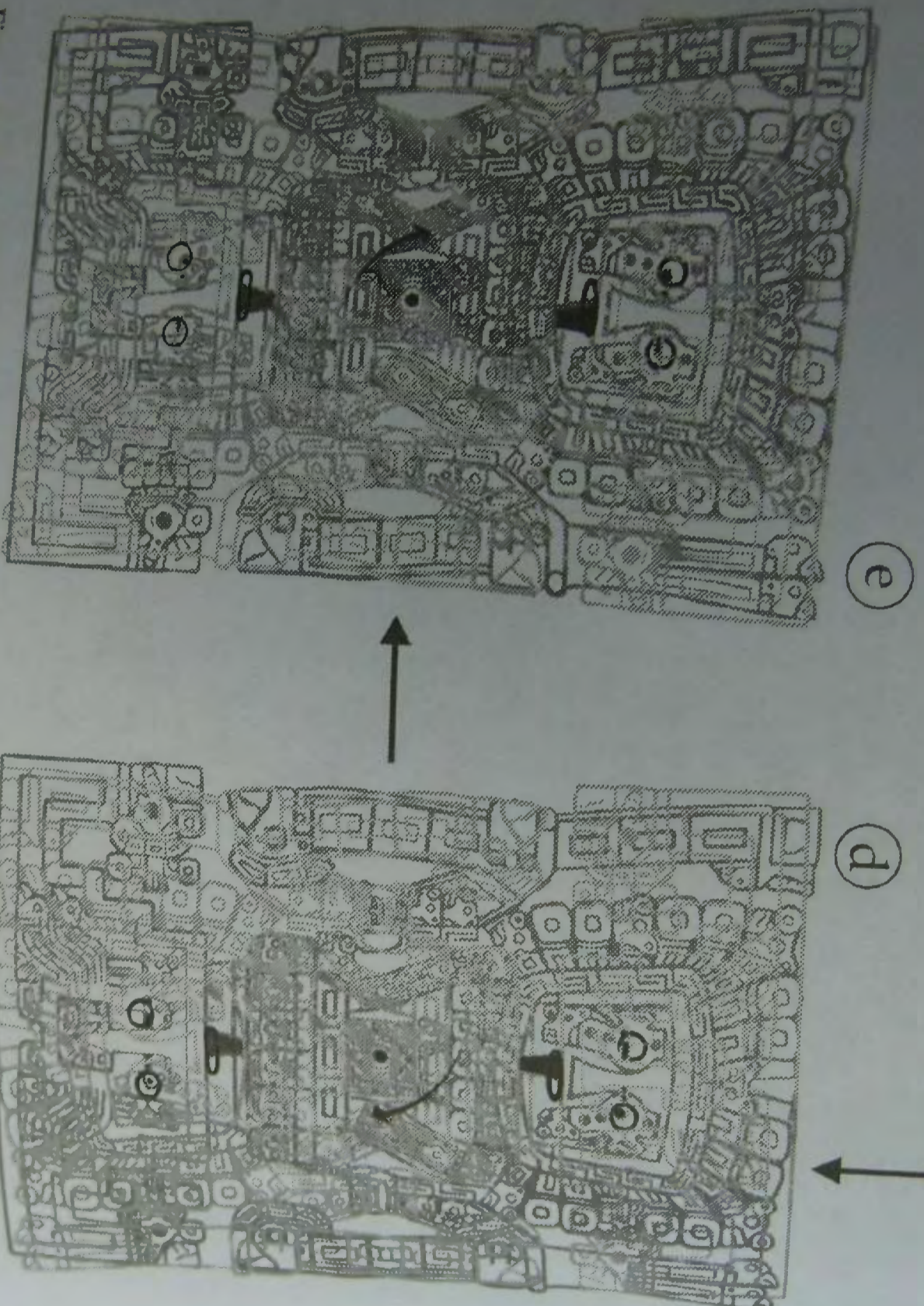

Figure A8. Following the instructions given by figure A7; (a) make an image of Viracocha (male); (b) make another image, the opposite of the Viracocha image (female); (c) turn the second image (female) upside-down. Now, by using the Maya Transformer decoding process, the two images are overlaid (d). The missing tongue from the Viracocha has relief is now restored (located) to right. Rotating the transparencies back and forth (d and e) about the epicentre (the circle located in the centre of the composite arrangement) the tongue of Viracocha waggles alternately from left to right. At the same time Viracocha closes each eye alternately. We again note that the observer should stand behind the doorway of the Gateway of the Sun raising one finger of each hand so that one finger frames either side of the doorway (figure A9). The angle of the Sun can now be measured through the doorway using parallax error derived by alternately opening and closing each eye in turn.

Not to scale

Figure A9. The Gateway of the Gateway to each error derived from fingers) as shown and a thumb—the 48" corresponds to varies from the till believed that the information using as far back as 15000

APPENDIX TWO

Secrets of the Ancients

Why and How They Encoded Their Secrets into Their Treasures

In *The Mayan Prophecies*, *The Supergods*, *The Tutankhamun Prophecies*, *The Lost Tomb of Viracocha* and *The Terracotta Warriors* I explained how the 'sun-king' leaders of the ancient Maya, Egyptians, Peruvians and Chinese possessed a scientific understanding of a very high order, one that modern man is only now beginning to grasp. They taught their people that the Sun controls fertility on Earth, that it controls personality determination (Sun-sign astrology) and that solar magnetic reversals bring periodic catastrophic destruction to Earth, erasing each civilisation in turn from the annals of history. These Supergods taught that the soul is imperishable, everlasting and, for the pure, destined for the stars; rebirth on Earth awaits the rest.

The mechanics of the reincarnation process imply that the super-knowledge, which takes many lifetimes to accumulate, could be acquired more quickly if individuals were able to build upon previous knowledge with each successive incarnation. But a new brain and heart, each incarnation, precludes such gains. So the purification process takes many more lifetimes than it otherwise might. To overcome this the ancients encoded their super-knowledge into their treasures. Rediscovery of the same knowledge, in the next incarnation, would enable a higher starting level of purification, giving the soul a better chance, they believed, of transmigration and transmutation into a star the next time around.

But how could the knowledge be 'written down' so as to guarantee its transmission over vast epochs of time? Throughout history, nations and languages have been wiped out by conquering armies and political regimes eager to impose their own beliefs on defeated nations. Ideas and cultures are lost through ideological succession. Natural disasters, floods, fire and earthquake likewise erase all evidence of earlier civilisations. Solar-inspired catastrophe cycles that periodically cause the Earth to tilt on its axis likewise defeat the transmission of knowledge.

Thus, it was important to preserve the ancient knowledge for themselves, to help them get to Heaven next time around. At the same time, it was also important to deny non-spiritual people access to the holy knowledge, meaning that if they were to preserve and safeguard it for themselves, they had to encode it.

Encoding Information Using Pictures

There are two preferred ways to 'write down' knowledge for posterity without the use of words. One way of encoding information is through the use of pictures: one picture tells a thousand words and all pictures are common to all people. Lord Pacal encoded his sacred knowledge into his Mayan transformers using pictures and mirror images of those pictures which when laid one upon the other reveal hundreds of other pictures. Plates 2, 3, 4, 5b, 6-13 and 24 show a few examples.

Encoding Information Using Numbers

Another way to encode information is by using numbers. The cultural common denominator, the number 10, is common to all mankind, because all of mankind has 10 fingers. Lord Pacal chose to use numbers in his encoding of solar magnetic cycles into the pyramid clues at Palenque, figure A17, and also to draw parallels with biblical quotations; plate 5b (detailed in figure A10) shows Lord Pacal wearing the esoteric number 144,000, mentioned in Revelation, on his forehead. The numbers they chose to convey astronomical and spiritual information are set down in figure 12.

Figures A11 to A17 show that the spiritual leaders of the Maya, Egyptians, Peruvians and Chinese all encoded the super-science of

shield of Monte Alban (plates 2 and 3) and analysis of the decoding (figure 9) revealed the southern point of the Star of David poking into the mouth of the Viracocha bas relief carving. Looking more closely at a line drawing of the bas relief (figure A5c) it becomes clear that the tongue of Viracocha is missing, which is highly unusual. The Sun God featured throughout South and Central America is almost always shown with his tongue poking out of his mouth (figure A6a-e).

The statue of Viracocha that stands in the middle of the Kalasassaya, just beyond the gateway, provides the next clue in helping to understand the meaning of the Viracocha bas relief line drawing. The statue carries a male figure in his right hand and a female figure in his left (figure A7).

Following the instructions leads us to arrange the Viracocha transformer transparencies as shown in figure A8, revealing the secret message that Viracocha encoded into his bas relief carving (figure A9); the Earth was destroyed on previous occasions when it tilted on its axis.

APPENDIX TWO

Secrets of the Ancients

Why and How they Encoded their Secrets into their Treasures

In *The Mayan Prophecies*, *The Supergods*, *The Tutankhamun Prophecies*, *The Lost Tomb of Viracocha* and *The Terracotta Warriors* I explained how the 'sun-king' leaders of the ancient Mayas, Egyptians, Peruvians and Chinese possessed a scientific understanding of a very high order, one that modern man is only now beginning to grasp. They taught their people that the Sun controls fertility on Earth, that it controls personality determination (Sun-sign astrology) and that solar magnetic reversals bring periodic catastrophic destruction to Earth, erasing each civilization in turn from the annals of history. These Supergods taught that the soul is imperishable, everlasting and, for the pure, destined for the stars; rebirth on Earth awaits the rest.

The mechanics of the reincarnation process imply that the super-knowledge, that takes many lifetimes to accumulate, could be acquired more quickly if individuals were able to build upon previous knowledge with each successive incarnation. But a new brain and heart, each incarnation, precludes such gains. So the purification process takes many more lifetimes than it otherwise might. To overcome this the ancients encoded their super-knowledge into their treasures. Rediscovery of the same knowledge, in the next incarnation, would enable a higher starting level of purification, giving the soul a better chance, they believed, of transmi-

The 144,000 Message of Lord Pacal

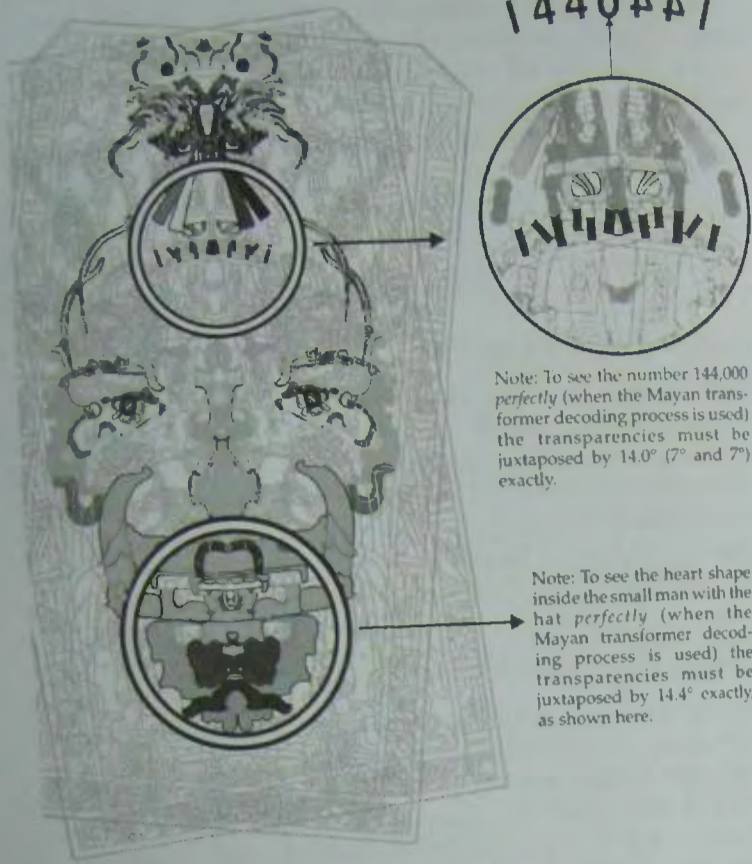

Note: To see the number 144,000 perfectly (when the Mayan transformer decoding process is used) the transparencies must be juxtaposed by 14.0° (7° and 7°) exactly.

Note: To see the heart shape inside the small man with the hat perfectly (when the Mayan transformer decoding process is used) the transparencies must be juxtaposed by 14.4° exactly, as shown here.

Figure A10. In the Bible those with 144,000 written on their foreheads represent the chosen few who will enter the Kingdom of Heaven. In this decoded picture, from the Amazing Lid of Palenque, Lord Pacal carries the number 144,000 on his forehead (above, top, circled) only when one transparency is inverted and overlaid onto the other, juxtaposed by 7° and 7° (7, 7). The perfect heart shape, contained within the composite picture of the small man with the hat (bottom, circled), can be completed only when the transparencies are each juxtaposed by 14.4° (7.2° and 7.2°). These messages taken together tell us that only the pure of heart will become one of the 144,000, like Lord Pacal.

The Sunspot Cycle Message of Lord Pacal

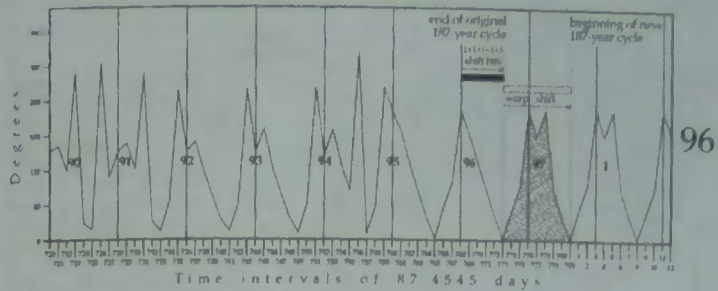

Figure A11. The computer-calculated version of the sunspot cycle shows that 96 microcycles of magnetic activity take place on the Sun every 187 years (the 97th cycle leads to an even longer cycle of 18,139 years). The 96-cycle sequence was known by ancient sun-worshipping civilisations who encoded the secret super-science of the Sun into their treasures. (Note: To save space the first 89 microcycles are not shown).

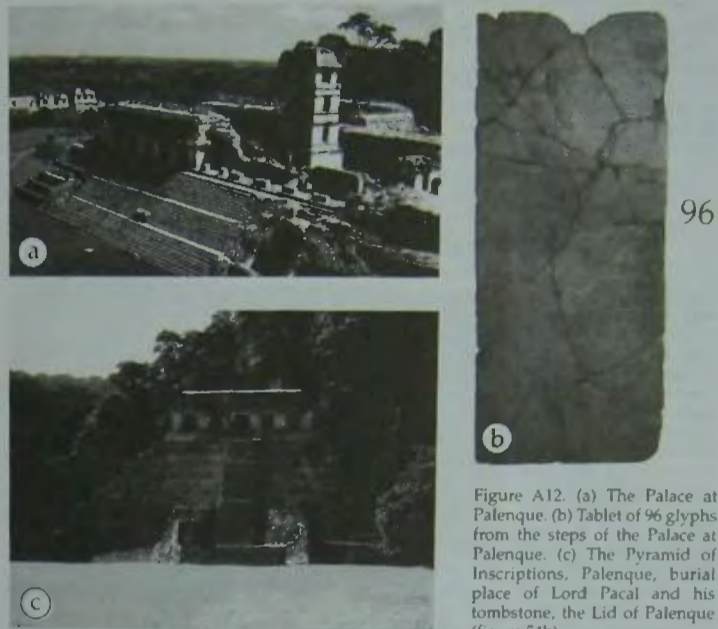
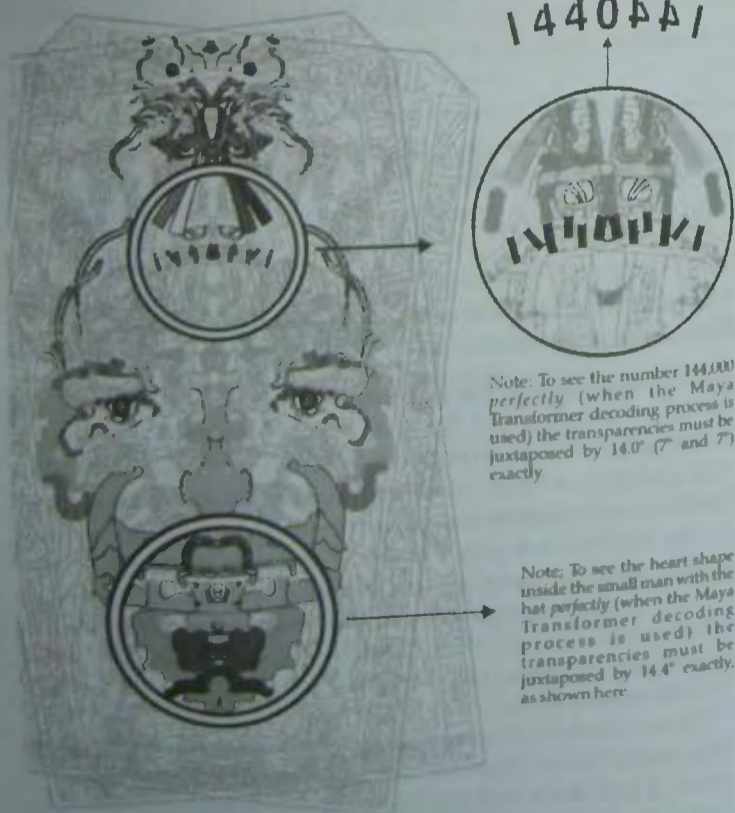

Figure A12. (a) The Palace at Palenque. (b) Tablet of 96 glyphs from the steps of the Palace at Palenque. (c) The Pyramid of Inscriptions, Palenque, burial place of Lord Pacal and his tombstone, the Lid of Palenque (figure 54b).

THE CELTIC CHRONICLES

The 144,000 Message of Lord Pacal



Note: To see the number 144,000 perfectly (when the Maya Transformer decoding process is used) the transparencies must be juxtaposed by 14.0° (7° and 7°) exactly.

Note: To see the heart shape inside the small man with the hat perfectly (when the Maya Transformer decoding process is used) the transparencies must be juxtaposed by 14.4° exactly, as shown here.

Figure A10. In the Bible those with 144,000 written on their foreheads represent the chosen few who will enter the Kingdom of Heaven. In this decoded picture, from the Amazing Lid of Palenque, Lord Pacal carries the number 144,000 on his forehead (above, top, circled) only when one transparency is inverted and overlaid onto the other, juxtaposed by 7° and 7° (7, 7). The perfect heart shape, contained within the composite picture of the small man with the hat (bottom, circled), can be completed only when the transparencies are each juxtaposed by 14.4° (7.2° and 7.2°). These messages taken together tell us that only the pure of heart will become one of the 144,000, like Lord Pacal.

APPENDIX TWO

gration and transmutation into a star the next time around.

But how could the knowledge be 'written down' so as to guarantee its transmission over vast epochs of time? Throughout history, nations and languages have been wiped out by conquering armies and political regimes eager to impose their own beliefs on defeated nations. Ideas and cultures are lost through ideological succession. Natural disasters, floods, fire and earthquake likewise erase all evidence of earlier civilizations. Solar-inspired catastrophe cycles that periodically cause the Earth to tilt on its axis likewise defeat the transmission of knowledge.

Thus, it was important to preserve the ancient knowledge for themselves, to help them get to Heaven next time around. At the same time, it was also important to deny non-spiritual people access to the holy knowledge meaning that if they were to preserve and safeguard it for themselves, they had to encode it.

Encoding Information Using Pictures

There are two preferred ways to 'write down' knowledge for posterity without the use of words. One way of encoding information is through the use of pictures; one picture tells a thousand words and all pictures are common to all people. Lord Pacal encoded his sacred knowledge into his Maya transformers using pictures and mirror images of those pictures which when laid one upon the other reveal hundreds of other pictures. Plates 2, 3, 4, 5b, 6-13 and 24 show a few examples.

Encoding Information Using Numbers

Another way to encode information is by using numbers. The cultural common denominator, the number 10, is common to all mankind, because all of mankind has 10 fingers. Lord Pacal chose to use numbers in his encoding of solar magnetic cycles into the pyramid clues at Palenque, figure A17 and also to draw parallels with biblical quotations; plate 5b (detailed in figure A10) shows Lord Pacal wearing the esoteric number 144,000, mentioned in Revelation, on his forehead. The numbers they chose to convey astronomical and spiritual information are set down in figure 12.

Figures A11 to A17 show that the spiritual leaders of the Mayas, Egyptians, Peruvians and Chinese all encoded the super-science of the Sun

The 144,000 Message of Lord Pacal

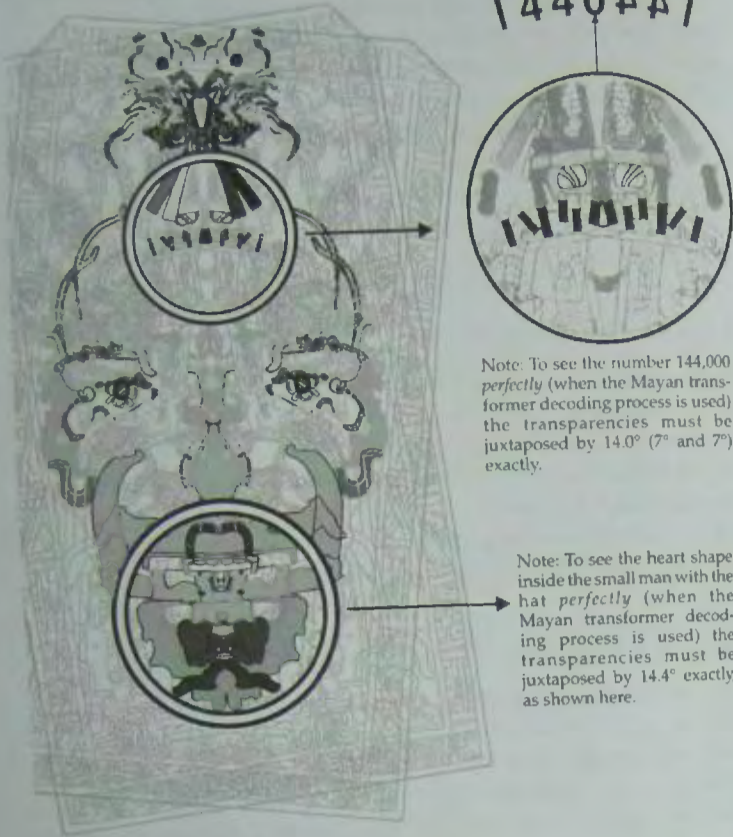

Note: To see the number 144,000 perfectly (when the Mayan transformer decoding process is used) the transparencies must be juxtaposed by 14.0° (7° and 7°) exactly.

Note: To see the heart shape inside the small man with the hat perfectly (when the Mayan transformer decoding process is used) the transparencies must be juxtaposed by 14.4° exactly, as shown here.

Figure A10. In the Bible those with 144,000 written on their foreheads represent the chosen few who will enter the Kingdom of Heaven. In this decoded picture, from the Amazing Lid of Palenque, Lord Pacal carries the number 144,000 on his forehead (above, top, circled) only when one transparency is inverted and overlaid on to the other, juxtaposed by 7° and 7° (7, 7). The perfect heart shape, contained within the composite picture of the small man with the hat (bottom, circled), can be completed only when the transparencies are each juxtaposed by 14.4° (7.2° and 7.2°). These messages taken together tell us that only the pure of heart will become one of the 144,000, like Lord Pacal.

The Sunspot Cycle Message of Lord Pacal

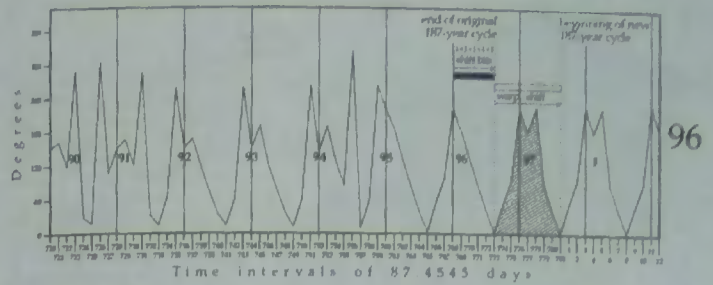

Figure A11. The computer-calculated version of the sunspot cycle shows that 96 microcycles of magnetic activity take place on the Sun every 187 years (the 97th cycle leads to an even longer cycle of 18,139 years). The 96-cycle sequence was known by ancient sun-worshipping civilisations who encoded the secret super-science of the Sun into their treasures. (Note: To save space the first 89 microcycles are not shown).

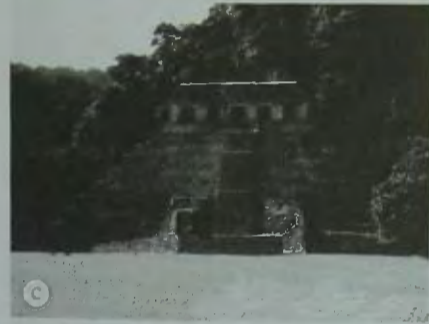
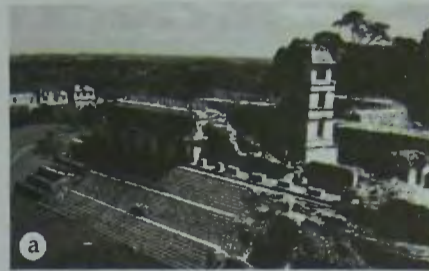
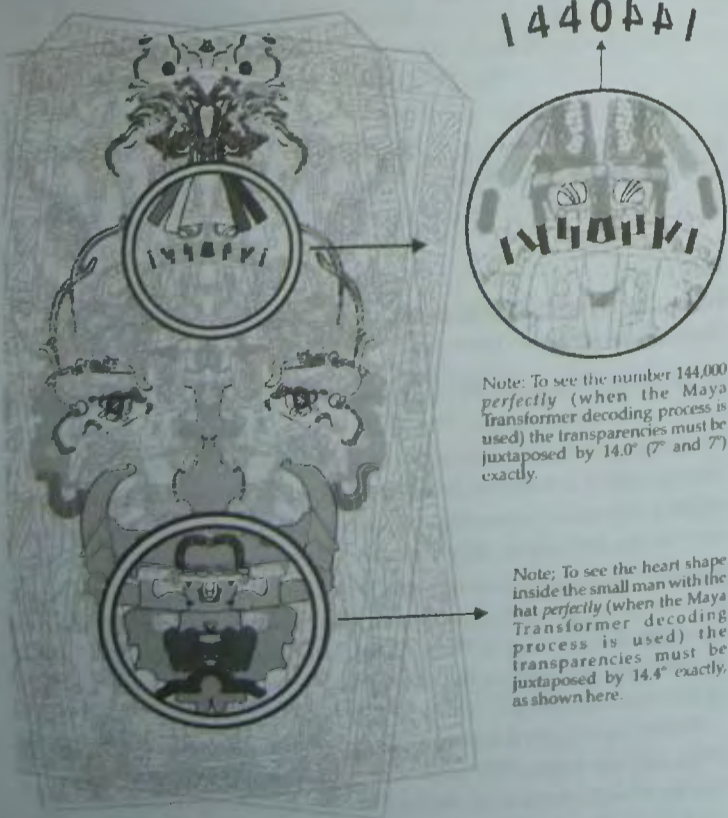

Figure A12. (a) The Palace at Palenque. (b) Tablet of 96 glyphs from the steps of the Palace at Palenque. (c) The Pyramid of Inscriptions, Palenque, burial place of Lord Pacal and his tombstone, the Lid of Palenque (figure 54b).

THE CELTIC CHRONICLES

The 144,000 Message of Lord Pacal



Note: To see the number 144,000 perfectly (when the Maya Transformer decoding process is used) the transparencies must be juxtaposed by 14.0° (7° and 7°) exactly.

Note: To see the heart shape inside the small man with the hat perfectly (when the Maya Transformer decoding process is used) the transparencies must be juxtaposed by 14.4° exactly, as shown here.

Figure A10. In the Bible those with 144,000 written on their foreheads represent the chosen few who will enter the Kingdom of Heaven. In this decoded picture, from the Amazing Lid of Palenque, Lord Pacal carries the number 144,000 on his forehead (above, top, circled) only when one transparency is inverted and overlaid on to the other, juxtaposed by 7° and 7° (7, 7). The perfect heart shape, contained within the composite picture of the small man with the hat (bottom, circled), can be completed only when the transparencies are each juxtaposed by 14.4° (7.2° and 7.2°). These messages taken together tell us that only the pure of heart will become one of the 144,000, like Lord Pacal.

APPENDIX TWO

gration and transmutation into a star the next time around.

But how could the knowledge be 'written down' so as to guarantee its transmission over vast epochs of time? Throughout history, nations and languages have been wiped out by conquering armies and political regimes eager to impose their own beliefs on defeated nations. Ideas and cultures are lost through ideological succession. Natural disasters, floods, fire and earthquake likewise erase all evidence of earlier civilizations. Solar-inspired catastrophe cycles that periodically cause the Earth to tilt on its axis likewise defeat the transmission of knowledge.

Thus, it was important to preserve the ancient knowledge for themselves, to help them get to Heaven next time around. At the same time, it was also important to deny non-spiritual people access to the holy knowledge meaning that if they were to preserve and safeguard it for themselves, they had to encode it.

Encoding Information Using Pictures

There are two preferred ways to 'write down' knowledge for posterity without the use of words. One way of encoding information is through the use of pictures; one picture tells a thousand words and all pictures are common to all people. Lord Pacal encoded his sacred knowledge into his Maya transformers using pictures and mirror images of those pictures which when laid one upon the other reveal hundreds of other pictures. Plates 2, 3, 4, 5b, 6-13 and 24 show a few examples.

Encoding Information Using Numbers

Another way to encode information is by using numbers. The cultural common denominator, the number 10, is common to all mankind, because all of mankind has 10 fingers. Lord Pacal chose to use numbers in his encoding of solar magnetic cycles into the pyramid clues at Palenque, figure A17 and also to draw parallels with biblical quotations; plate 5b (detailed in figure A10) shows Lord Pacal wearing the esoteric number 144,000, mentioned in Revelation, on his forehead. The numbers they chose to convey astronomical and spiritual information are set down in figure 12.

Figures A11 to A17 show that the spiritual leaders of the Mayas, Egyptians, Peruvians and Chinese all encoded the super-science of the Sun

The 144,000 Message of Lord Pacal

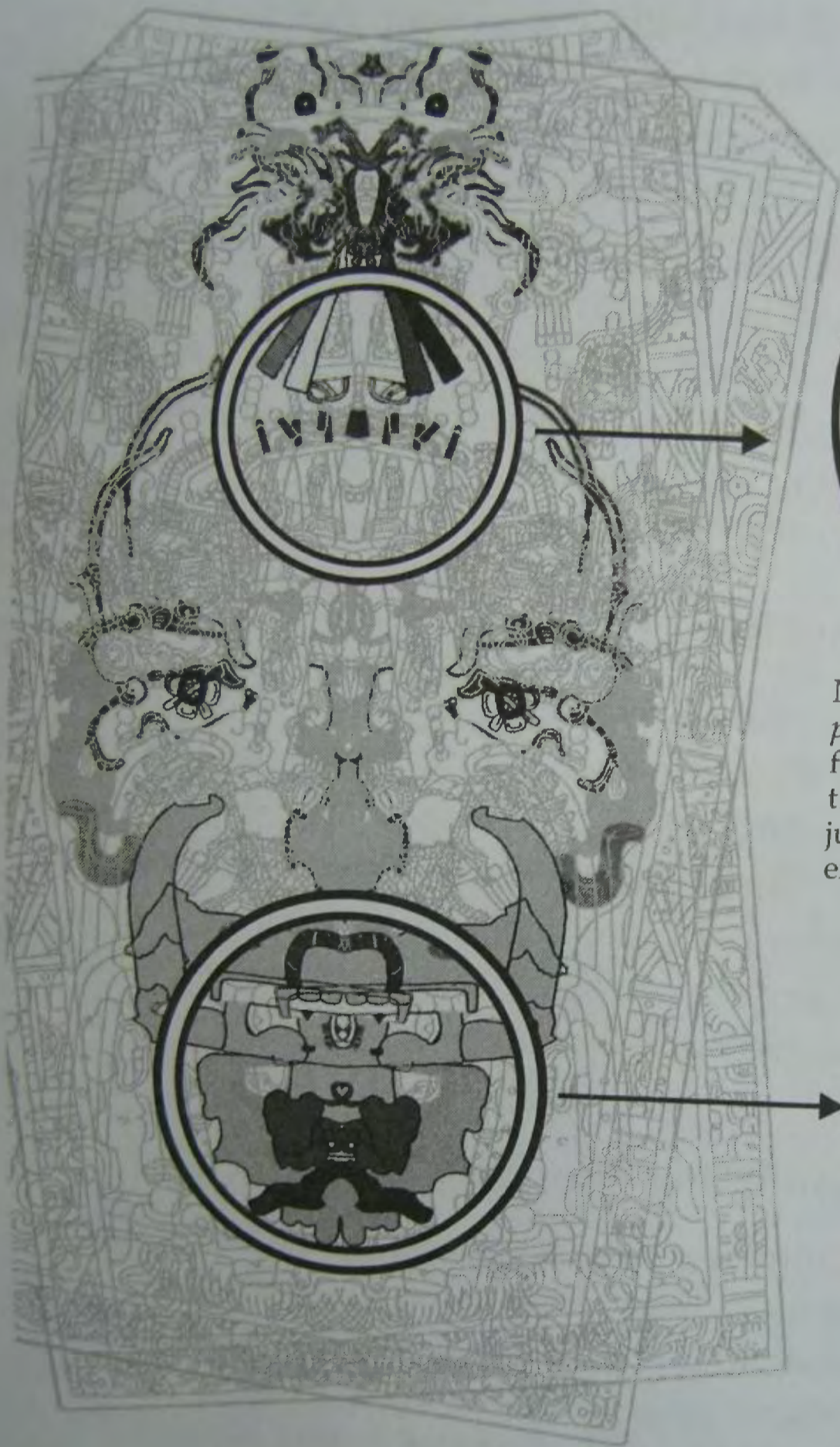

| 44000 |



Note: To see the number 144,000 perfectly (when the Mayan transformer decoding process is used) the transparencies must be juxtaposed by 14.0° (7° and 7°) exactly.

Note: To see the heart shape inside the small man with the hat perfectly (when the Mayan transformer decoding process is used) the transparencies must be juxtaposed by 14.4° exactly, as shown here.

Figure A10. In the Bible those with 144,000 written on their foreheads represent the chosen few who will enter the Kingdom of Heaven. In this decoded picture, from the Amazing Lid of Palenque, Lord Pacal carries the number 144,000 on his forehead (*above, top, circled*) only when one transparency is inverted and overlaid onto the other, juxtaposed by 7° and 7° ($7, 7$). The perfect heart shape, contained within the composite picture of the small man with the hat (*bottom, circled*), can be completed only when the transparencies are each juxtaposed by 14.4° (7.2° and 7.2°). These messages taken together tell us that only the pure of heart will become one of the 144,000, like Lord Pacal.

The 144,000 Message
of Lord Pacal

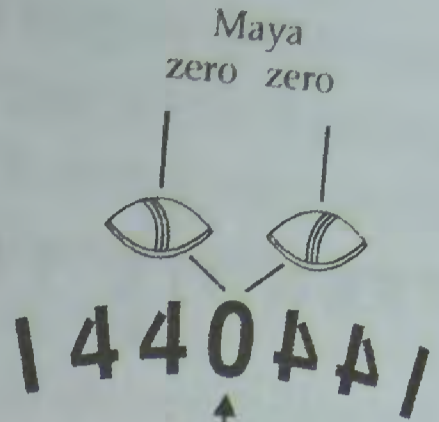
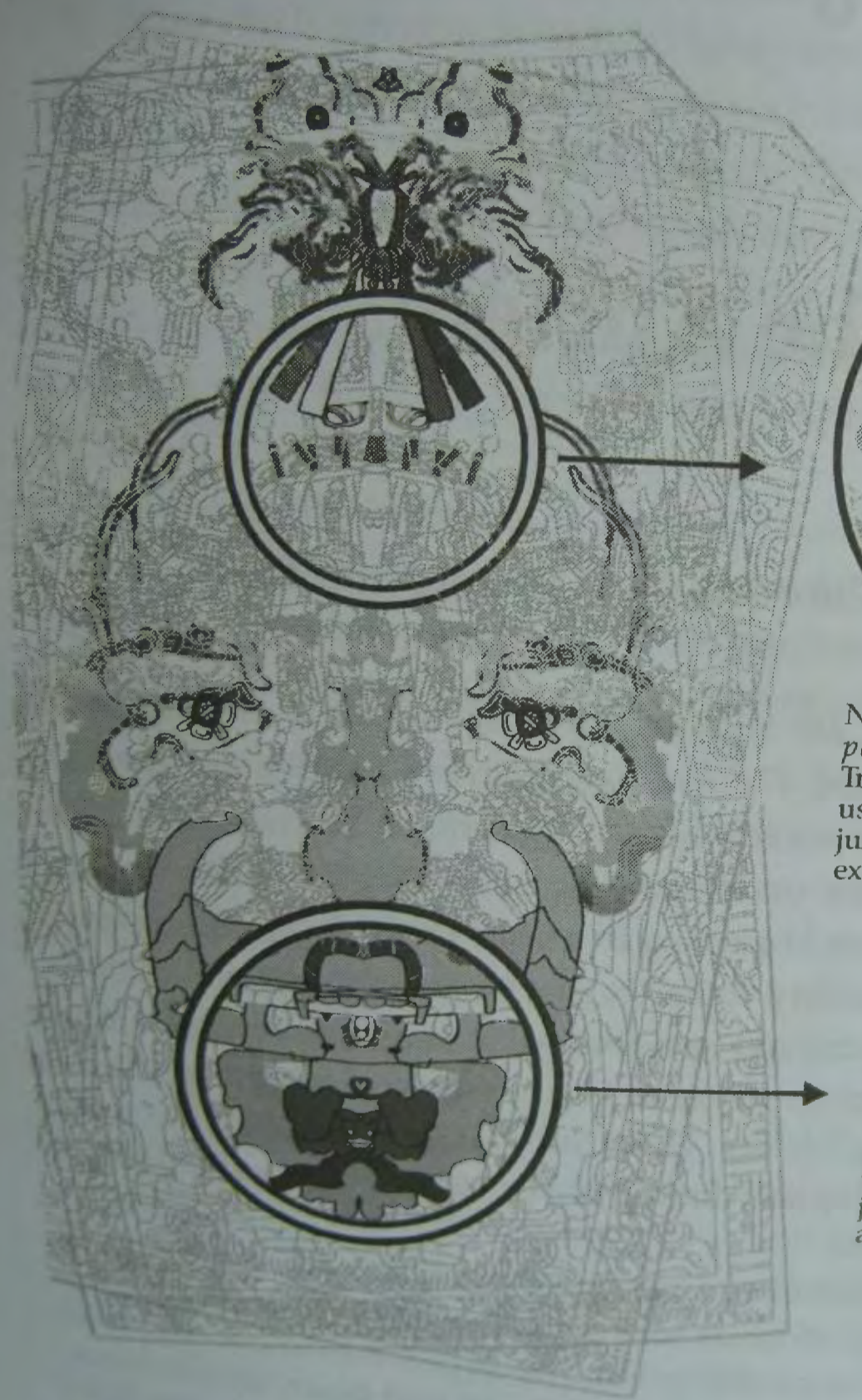

Note: To see the number 144,000 perfectly (when the Maya Transformer decoding process is used) the transparencies must be juxtaposed by 14.0° (7° and 7°) exactly.

Note; To see the heart shape inside the small man with the hat perfectly (when the Maya Transformer decoding process is used) the transparencies must be juxtaposed by 14.4° exactly, as shown here.

Figure A10. In the Bible those with 144,000 written on their foreheads represent the chosen few who will enter the Kingdom of Heaven. In this decoded picture, from the Amazing Lid of Palenque, Lord Pacal carries the number 144,000 on his forehead (above, top, circled) only when one transparency is inverted and overlaid on to the other, juxtaposed by 7° and 7° ($7, 7$). The perfect heart shape, contained within the composite picture of the small man with the hat (bottom, circled) can be completed only when the transparencies are each juxtaposed by 14.4° (7.2° and 7.2°). These messages taken together tell us that only the pure of heart will become one of the 144,000, like Lord Pacal.

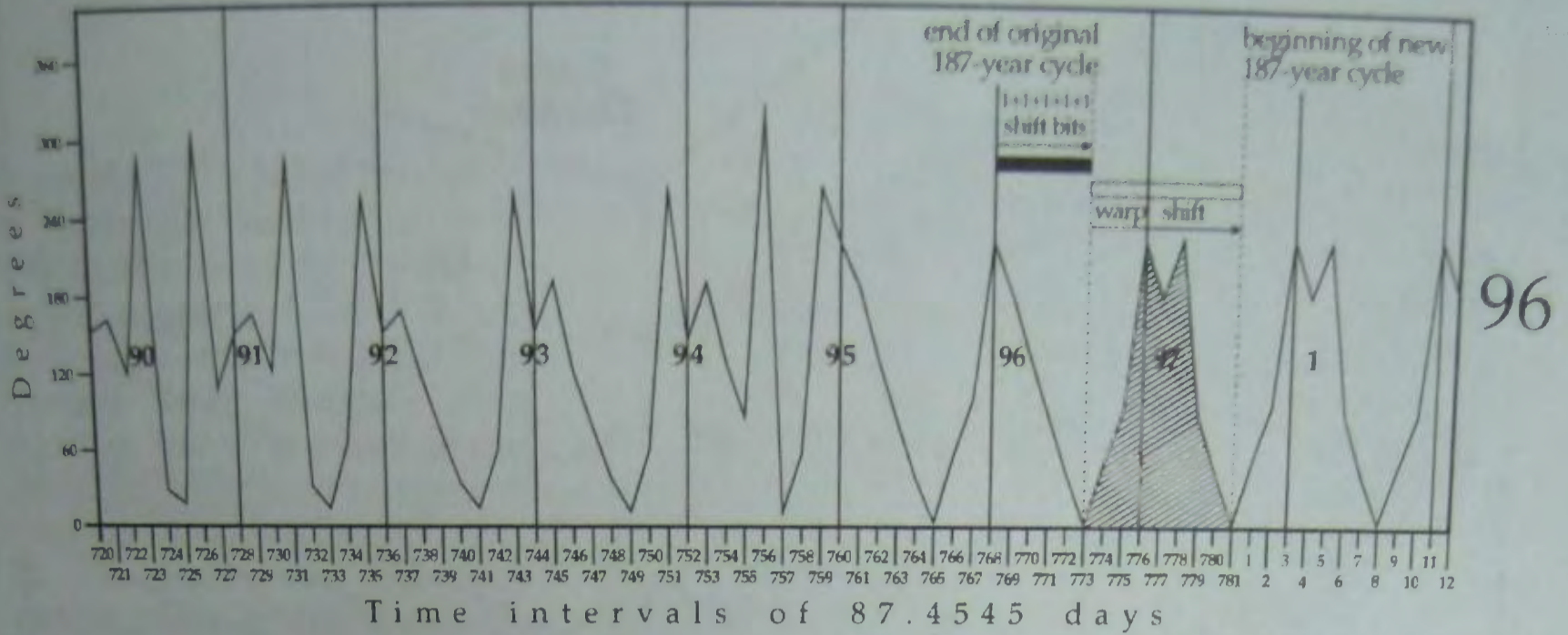
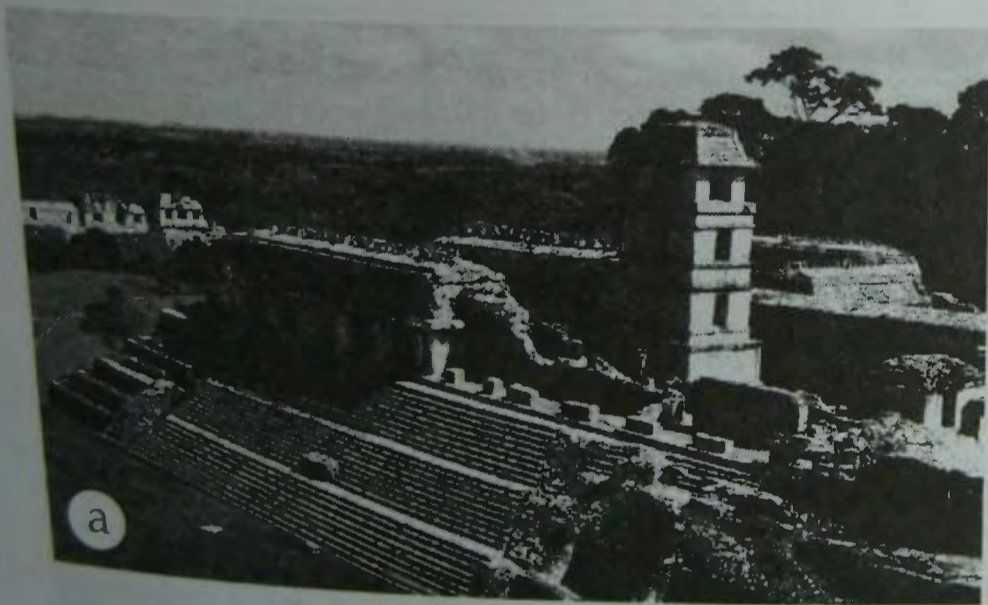

Figure A11. The computer-calculated version of the sunspot cycle shows that 96 microcycles of magnetic activity take place on the Sun every 187 years (the 97th cycle leads to an even longer cycle of 18,139 years). The 96-cycle sequence was known by ancient sun-worshipping civilisations who encoded the secret super-science of the Sun into their treasures. (Note: To save space the first 89 microcycles are not shown).



a



c

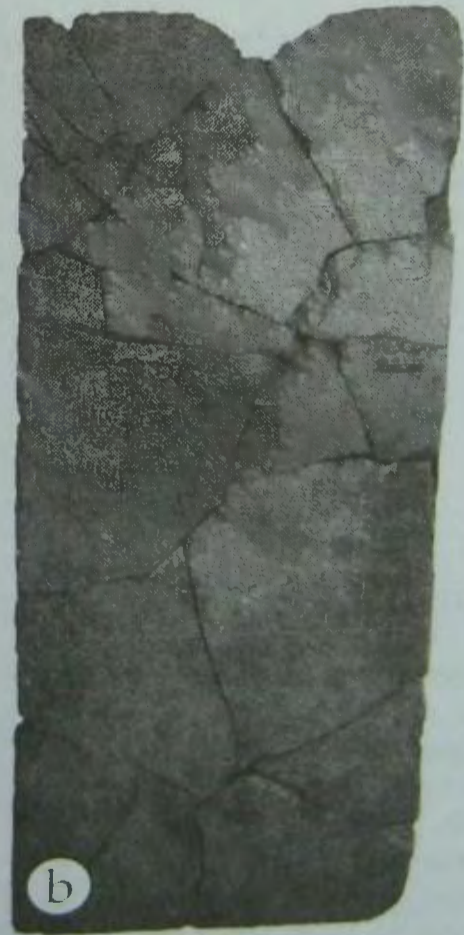

96

b

Figure A12. (a) The Palace at Palenque. (b) Tablet of 96 glyphs from the steps of the Palace at Palenque. (c) The Pyramid of Inscriptions, Palenque, burial place of Lord Pacal and his tombstone, the Lid of Palenque (figure 54b).

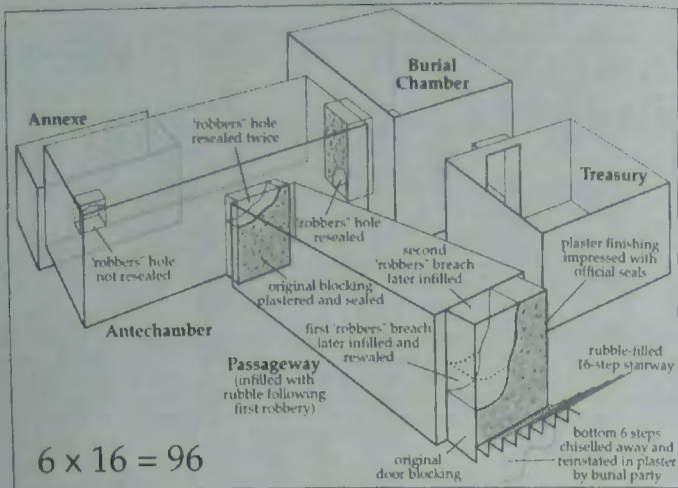

Figure A13. According to archaeologists, the bottom 6 steps of the 16-step stairway leading to Tutankhamun's tomb were chiselled away by the burial party to 'permit access of larger pieces of furniture' into the tomb. The steps, originally stone, were reinstated in plaster by the same burial party. But why would a burial party seal a tomb and then repair a broken stairway before filling in the stairway with rubble behind themselves? This would simply invite others to use the steps in the future, to gain access to a solid wall. The 6 and the 16 are astronomically significant: $6 \times 16 = 96$, the number of magnetic cycles in one sunspot cycle.

999 in the Tomb of Viracocha Pachacamac

Figure A14. The coffin lid was tied down by 9 copper straps along each edge (9,9,9,9), a number unique to the Supergods. The vertical edges, down each corner, likewise carried the same number of straps (9,9,9,9). He was accompanied by eight others, nine (9) in all. This was no ordinary man. Like the other two sun-kings, Lord Pacal of Mexico (9,9,9,9) and Tutankhamun (9,9,9,9) of Egypt, this man was a Supergod, later revered by the Incas.

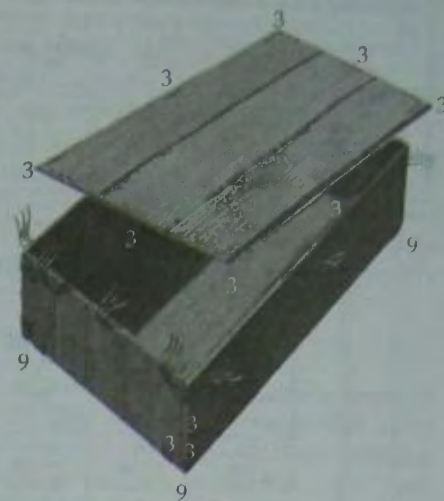

Figure A15. The lid of the coffin of Viracocha Pachacamac was tied to the sides by 3 sets of copper straps (3, 3, 3), 9 in all, along each side (9, 9, 9, 9). The corners were likewise tied together, and to the floor of the coffin, with the same number of straps, 9 at each corner (9, 9, 9, 9). The tomb was the final resting place of the Viracocha Pachacamac and eight companions, 9 in all. The corner brackets of the King of Hochdori's carriage were pinned to the carriage platform by 9 nails (9, 9, 9, 9) and 9 dinner plates were stored on the carriage.

The 999 Message of Tutankhamun



Figure A16. Door seals and object seals from the tomb of Tutankhamun showing the so-called 'prisoners', groups of 9 individuals (9, 9, 9, 9, 9) bound by rope around the neck and arms. Each rope terminates with a lotus flower, the epitome of sun worship, suggesting that the 'prisoners' were in 'divine captivity' on Earth. [The taking of prisoners was also a metaphor for 'thou shall not kill']. Tutankhamun was also buried in 9 coffins, one inside the other.

The Sunspot Cycle Message of Lord Pacal

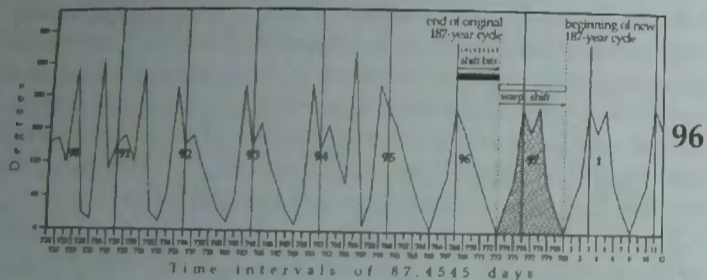

Figure A11. The computer-calculated version of the sunspot cycle shows that 96 microcycles of magnetic activity take place on the Sun every 187 years (the 97th cycle leads to an even longer cycle of 18,139 years). The 96-cycle sequence was known by ancient sun worshipping civilizations who encoded the secret super-science of the Sun into their treasures. (Note: to save space the first 89 microcycles are not shown).

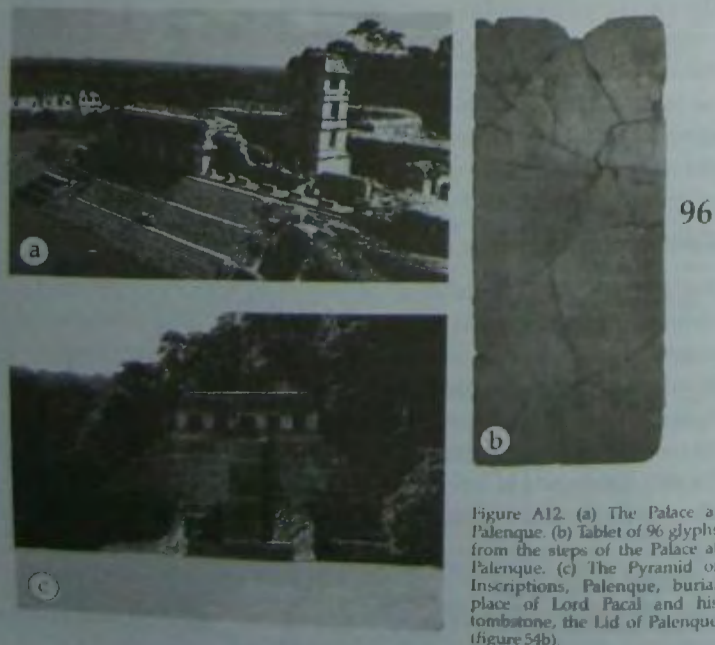

Figure A12. (a) The Palace at Palenque. (b) Tablet of 96 glyphs from the steps of the Palace at Palenque. (c) The Pyramid of Inscriptions, Palenque, burial place of Lord Pacal and his tombstone, the Lid of Palenque (figure 54b).

and the higher orders of spirituality into their treasures, using numbers, for rediscovery next time in their next incarnation on Earth should they fail to make it to Heaven this time around.

Studying these numbers, it becomes clear that the ancients were trying to explain that the purpose of this physical life on Earth is for each individual to purify the soul within, as a pre-requisite for entry into the kingdom of Heaven. This is achieved when the aspirant successfully converts the body, the beast (666), into Godly energy, the soul (999), which the scriptures tell us can only be done through 'loving our neighbour'. Love purifies the heart, which in turn purifies the soul.

How the Soul gets to Heaven

In 1915 the physicist Albert Einstein published his General Theory of Relativity containing his equation $E=mc^2$, which means that Energy equals mass multiplied by the speed of light (C) squared. This means that Energy can be converted to mass. The Bible teaches that God is Light [which modern science recognises as electromagnetic energy] (E).

The Bible also teaches that God made man in his own image, which is revealing because man can only grow to a certain size; to grow further he must throw away a sperm. Likewise a woman, to grow further, must throw away an egg.

Christianity also teaches that God is good and God is love. The only thing better than God, therefore, must be more God. By making man in his own image God reveals that he cannot grow, at least not without throwing a piece of himself away. And it seems that this is precisely what must have happened when the physical Universe was created. In the beginning, God threw away some of his energy (E) [for the sake of explanation, say about 5%]. The energy converted into mass, the physical Universe. In moving across Einstein's equation the (+) [for example] energy must change its sign to (-), a simple rule of algebra. This tells us that the physical Universe must therefore be the opposite of God, which means that the physical Universe and everything in it, including the Earth, must be Hell. It must also mean that everything in the carbon-based Universe, including trees, flowers and physical bodies must be the Devil [666], which we have already determined to be the opposite of God [999]. So when Christianity says bad souls go to Hell, it simply means that bad souls

The Sunspot Cycle Message of Tutankhamun

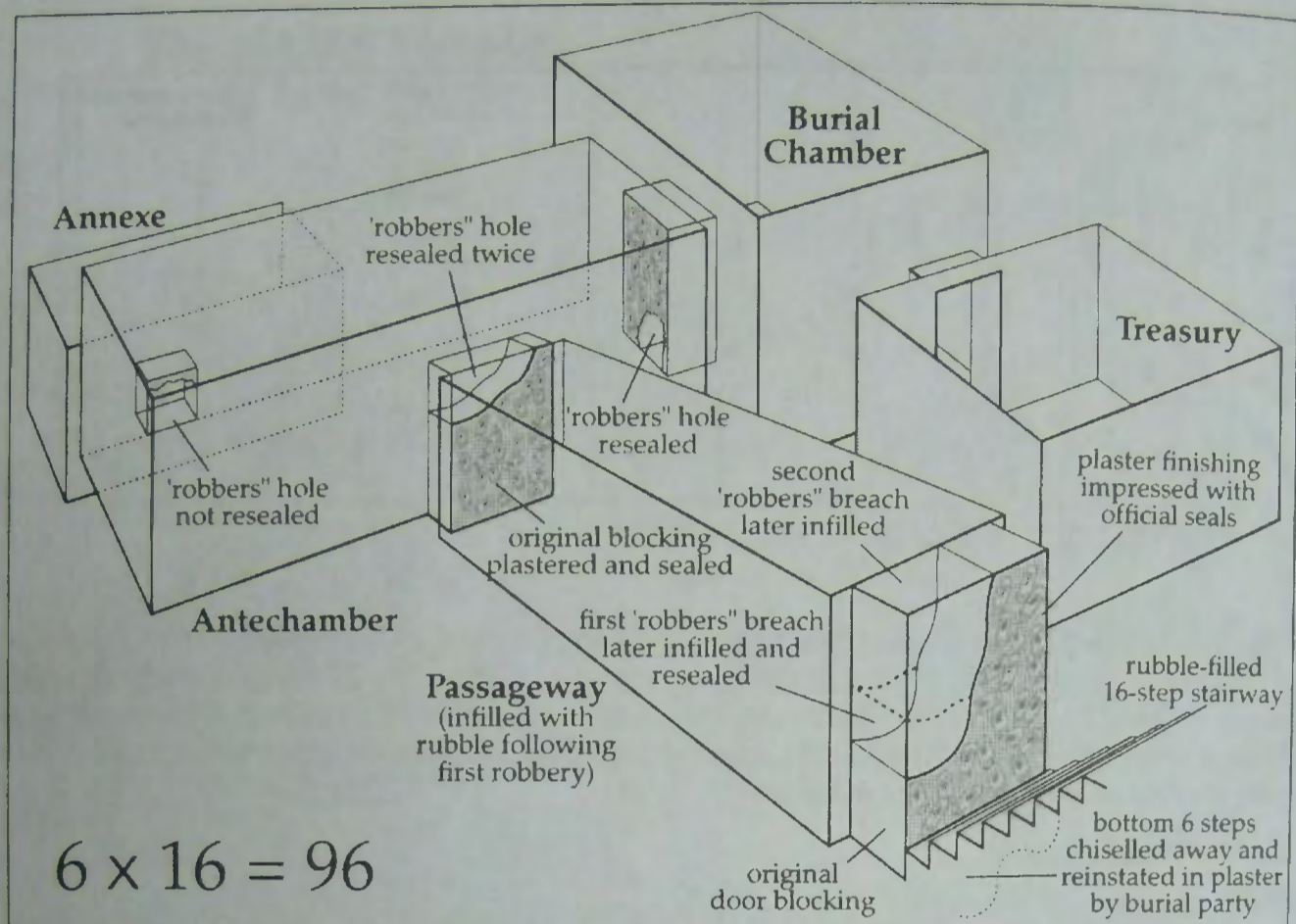

Figure A13. According to archaeologists, the bottom 6 steps of the 16-step stairway leading to Tutankhamun's tomb were chiselled away by the burial party to 'permit access of larger pieces of furniture' into the tomb. The steps, originally stone, were reinstated in plaster by the same burial party. But why would a burial party seal a tomb and then repair a broken stairway before filling in the stairway with rubble behind themselves? This would simply invite others to use the steps in the future, to gain access to a solid wall. The 6 and the 16 are astronomically significant: $6 \times 16 = 96$, the number of magnetic cycles in one sunspot cycle.

999 in the Tomb of Viracocha Pachacamac

Figure A14. The coffin lid was tied down by 9 copper straps along each edge (9,9,9,9), a number unique to the Supergods. The vertical edges, down each corner, likewise carried the same number of straps (9,9,9,9). He was accompanied by eight others, nine (9) in all. This was no ordinary man. Like the other two sun-kings, Lord Pacal of Mexico (9,9,9,9) and Tutankhamun (9,9,9,9) of Egypt, this man was a Supergod, later revered by the Incas.



The Sunspot Cycle Message of Lord Pacal

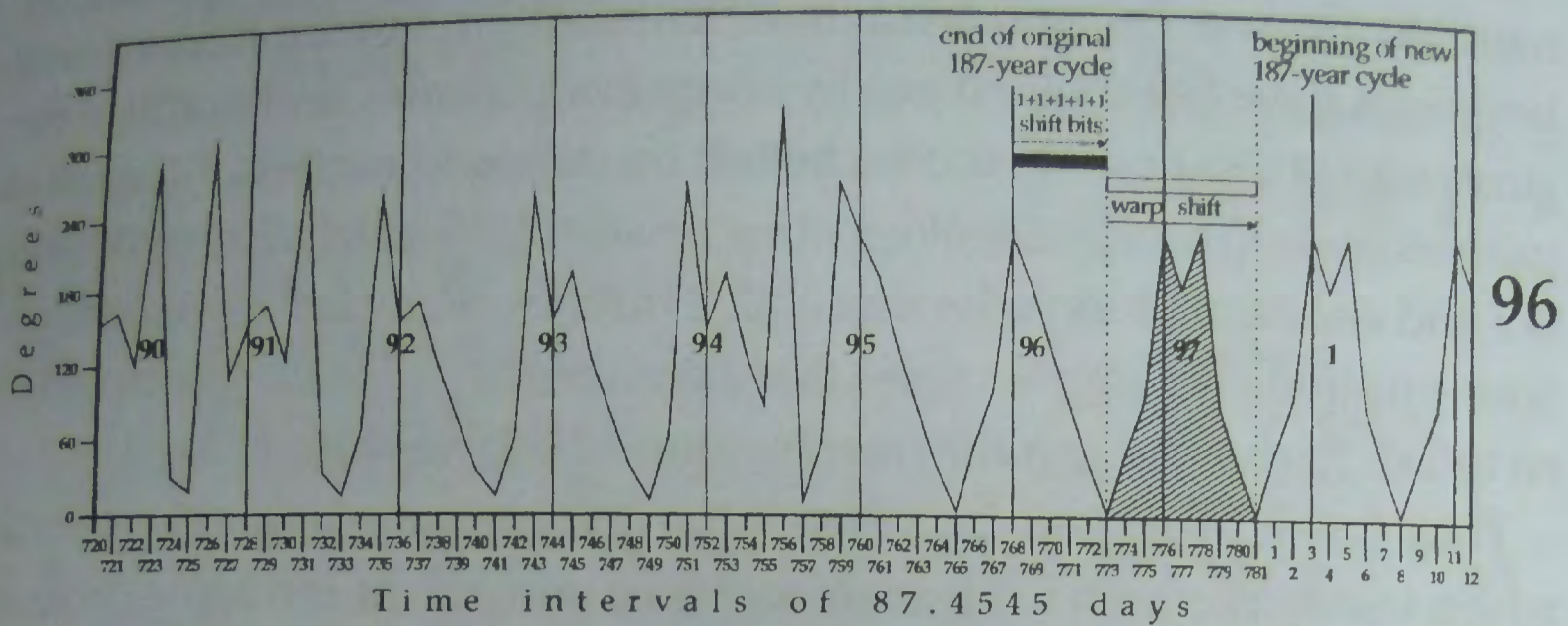
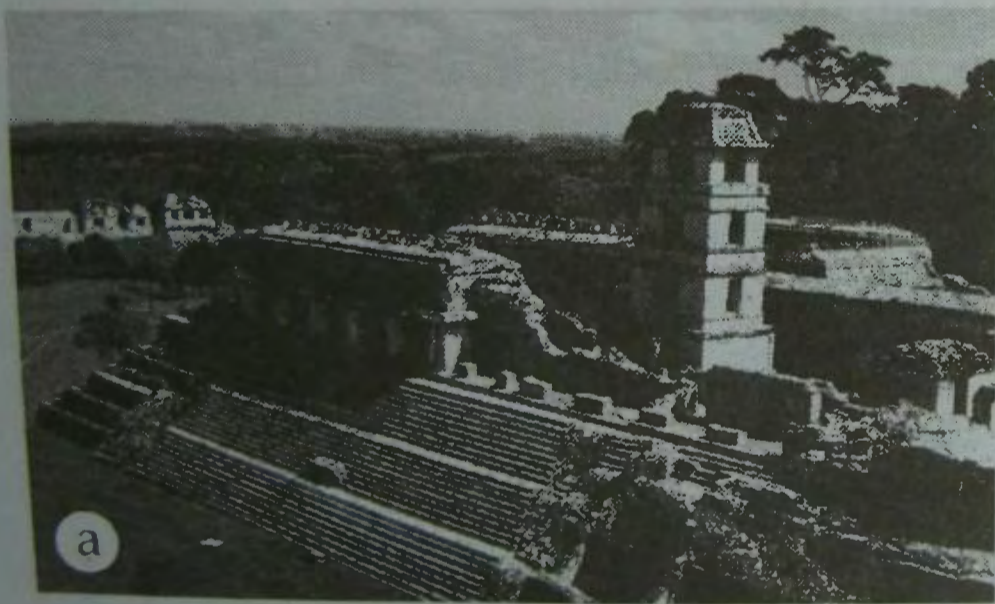

Figure A11. The computer-calculated version of the sunspot cycle shows that 96 microcycles of magnetic activity take place on the Sun every 187 years (the 97th cycle leads to an even longer cycle of 18,139 years). The 96-cycle sequence was known by ancient sun worshipping civilizations who encoded the secret super-science of the Sun into their treasures. (Note: to save space the first 89 microcycles are not shown).



a



c

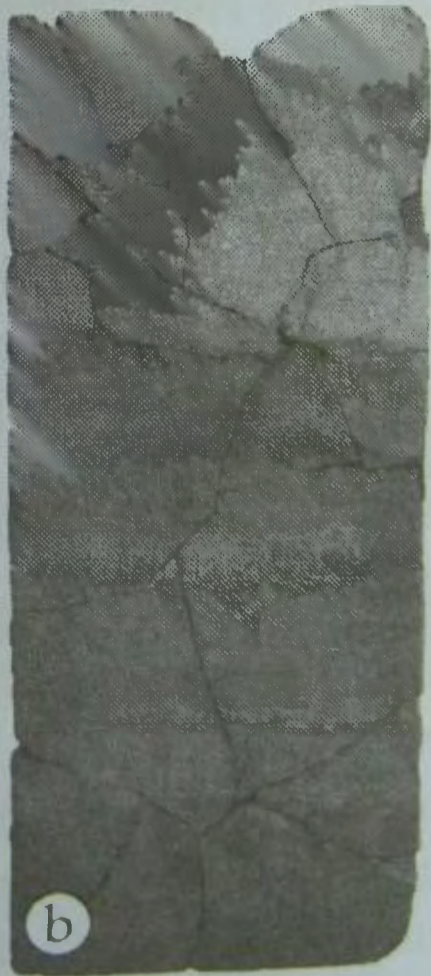

b

96

Figure A12. (a) The Palace at Palenque. (b) Tablet of 96 glyphs from the steps of the Palace at Palenque. (c) The Pyramid of Inscriptions, Palenque, burial place of Lord Pacal and his tombstone, the Lid of Palenque (figure 54b).

The Sunspot Cycle Message of Lord Pacal

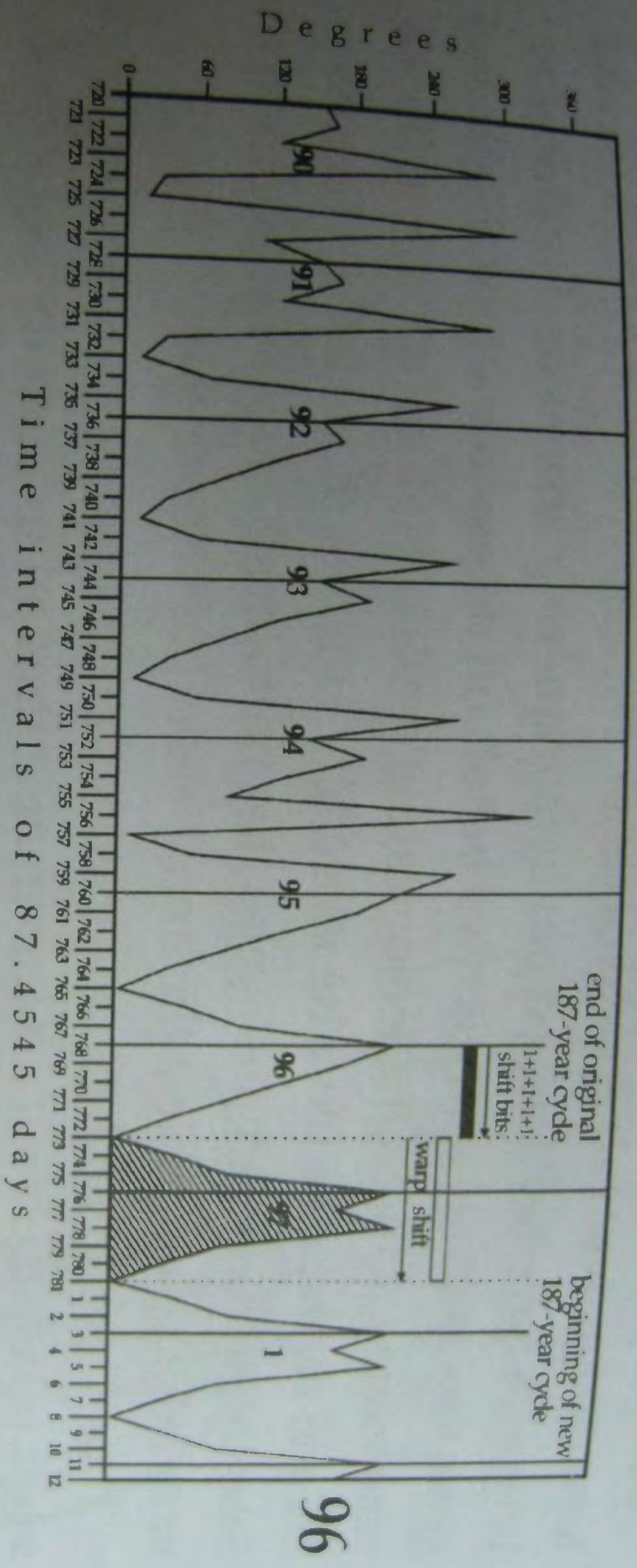
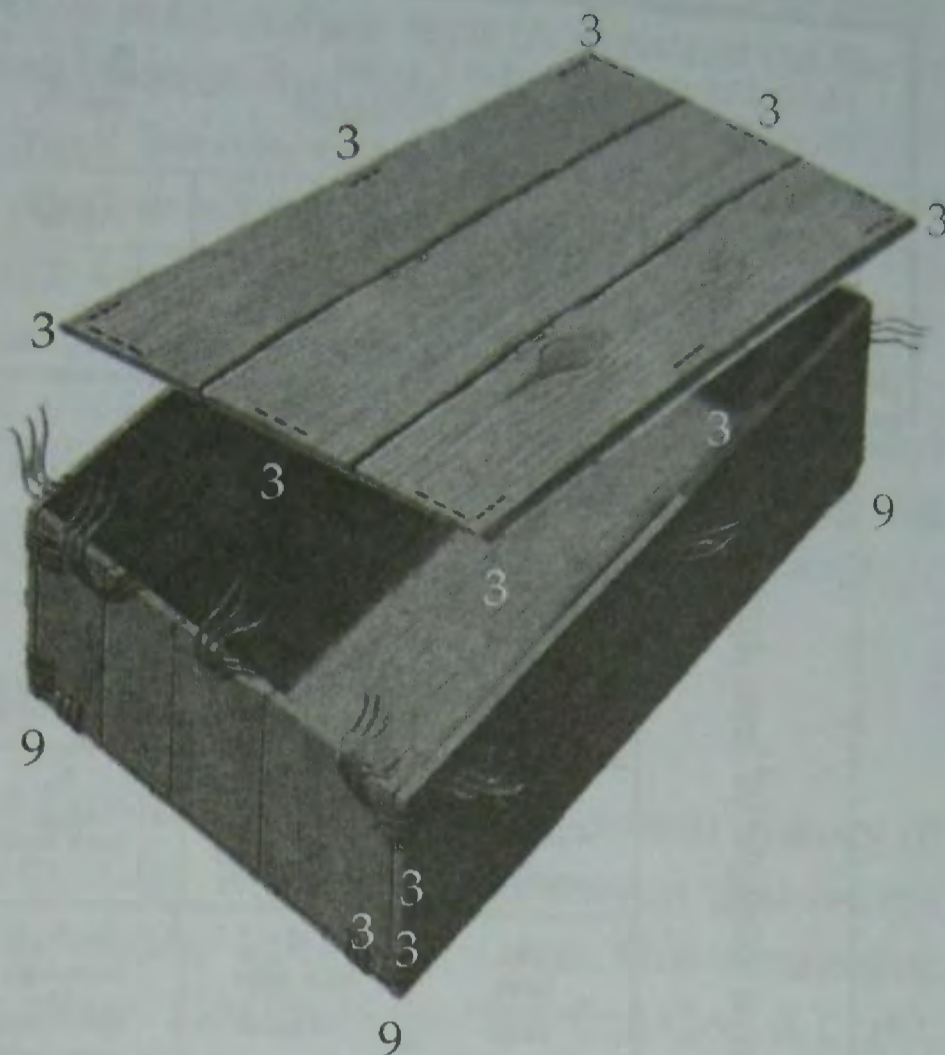

Figure A11. The computer-calculated version of the sunspot cycle shows that 96 microcycles of magnetic activity take place on the Sun every 187 years (the 97th cycle leads to an even longer cycle of 18,139 years). The 96-cycle sequence was known by ancient sun worshipping civilizations who encoded the secret super-science of the Sun into their treasures. (Note: to save space the first 89 microcycles are not shown).



Figure A15. The lid of the coffin of Viracocha Pachacamac was tied to the sides by 3 sets of copper straps (3, 3, 3), 9 in all, along each side (9, 9, 9, 9). The corners were likewise tied together, and to the floor of the coffin, with the same number of straps, 9 at each corner (9, 9, 9, 9). The tomb was the final resting place of the Viracocha Pachacamac and eight companions, 9 in all. The corner brackets of the King of Hochdorf's carriage were pinned to the carriage platform by 9 nails (9, 9, 9, 9) and 9 dinner plates were stored on the carriage.



The 9 9 9 Message of Tutankhamun



Figure A16. Door seals and object seals from the tomb of Tutankhamun showing the so-called 'prisoners', groups of 9 individuals (9, 9, 9, 9, 9) bound by rope around the neck and arms. Each rope terminates with a lotus flower, the epitome of sun worship, suggesting that the 'prisoners' were in 'divine captivity' on Earth. [The taking of prisoners was also a metaphor for 'thou shall not kill']. Tutankhamun was also buried in 9 coffins, one inside the other.

The Sunspot Cycle Message of Tutankhamun

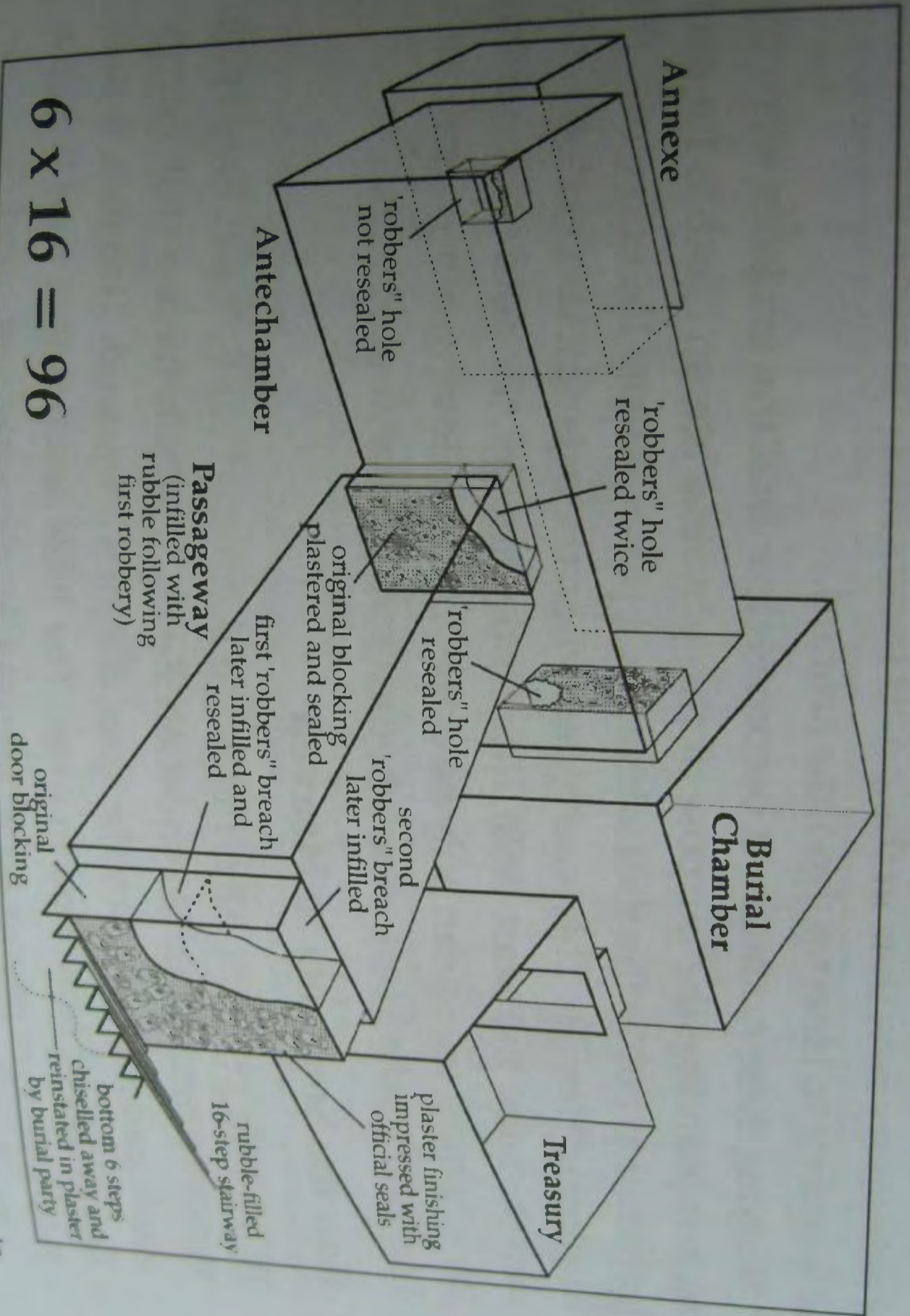

Figure A13. According to archaeologists, the bottom 6 steps of the 16-step stairway leading to Tutankhamun's tomb were chiselled away by the burial party to 'permit access of larger pieces of furniture' into the tomb. The steps, originally stone, were reinstated in plaster by the same burial party. But why would a burial party seal a tomb and then repair a broken stairway before filling-in the stairway with rubble behind themselves? This would simply invite others to use the steps in the future, to gain access to a solid wall. The 6 and the 16 are astronomically significant; $6 \times 16 = 96$, the number of magnetic cycles in one sunspot cycle.

999 in the tomb of Viracocha Pachacamac

Figure A14. The coffin lid was tied...



F c Pa
si Pa
st ea
col
tog
the
nur
cor
was
the
and
The
King
were
plato
and 9
stored

The 999 Message of Lord Pacal

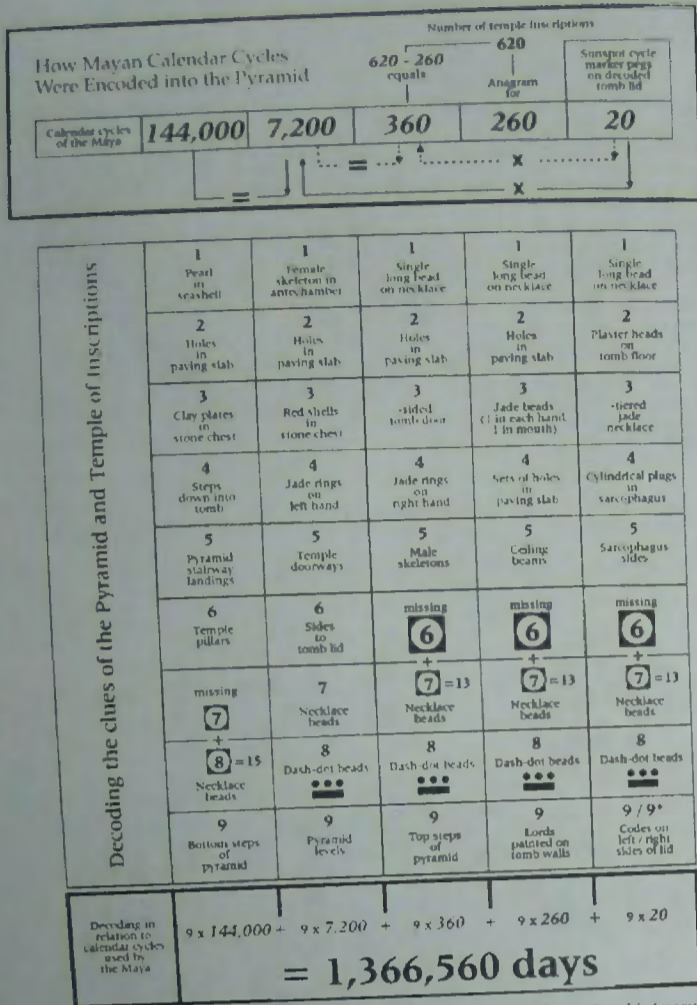

Figure A17. Lord Pacal encoded the number of the Supergods 9, 9, 9, 9, 9 into his treasures in the Temple of Inscriptions, Palenque. The number of objects in the tomb cleverly construct a numerical matrix that conceals information: 9 multiplied by the Mayan calendar cycles of time, in days, amounts to 1,366,560 days; the 'Birth of Venus' for the Maya. Moreover, $1 + 3 + 3 + 6 + 6 + 5 + 6 + 0 = 9$, the number of a Supergod. They were attempting to convey the fact that Lord Pacal was the spiritual 'rebirth of Venus' (Jesus).

the Sun and the higher orders of spirituality into their treasures, using numbers, for rediscovery next time in their next incarnation on Earth should they fail to make it to Heaven this time around.

Studying these numbers, it becomes clear that the ancients were trying to explain that the purpose of this physical life on Earth is for each individual to purify the soul within, as a pre-requisite for entry into the kingdom of Heaven. This is achieved when the aspirant successfully converts the body, the beast (666), into godly energy, the soul (999), which the scriptures tell us can only be done through 'loving our neighbour'. Love purifies the heart, which in turn purifies the soul.

How the Soul Gets to Heaven

In 1915 the physicist Albert Einstein published his General Theory of Relativity containing his equation $E=mc^2$, which means that energy equals mass multiplied by the speed of light (c) squared. This means that energy can be converted to mass. The Bible teaches that God is Light, which modern science recognises as electromagnetic energy (E).

The Bible also teaches that God made man in his own image, which is revealing because man can only grow to a certain size; to grow further he must throw away a sperm. Likewise a woman, to grow further, must throw away an egg.

Christianity also teaches that God is good and God is love. The only thing better than God, therefore, must be more God. By making man in his own image God reveals that he cannot grow, at least not without throwing a piece of himself away. And it seems that this is precisely what must have happened when the physical Universe was created. In the beginning, God threw away some of his energy (E) (for the sake of explanation, say about 5%). The energy converted into mass, the physical Universe. In moving across Einstein's equation, the (+) (for example) energy must change its sign to (-), a simple rule of algebra. This tells us that the physical Universe must therefore be the opposite of God, which means that the physical Universe and everything in it, including the Earth, must be Hell. It must also mean that everything in the carbon-based Universe, including trees, flowers and physical bodies must be the Devil (666), which we have already determined to be the opposite of God (999). So when Christianity says bad souls

THE CELTIC CHRONICLES

The Sunspot Cycle Message of Tutankhamun

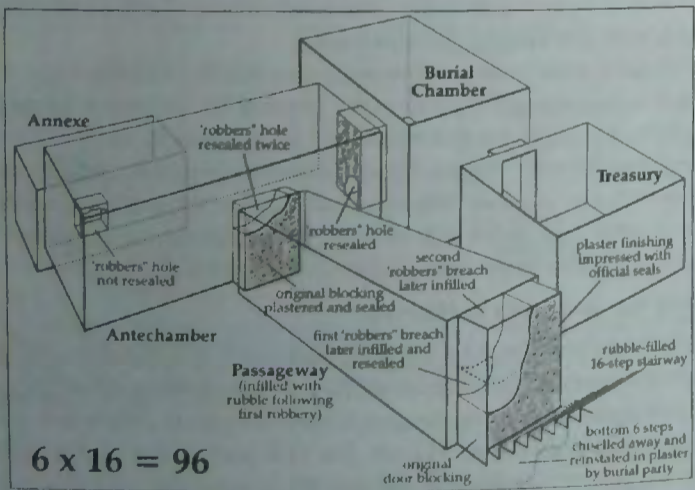

Figure A13. According to archaeologists, the bottom 6 steps of the 16-step stairway leading to Tutankhamun's tomb were chiselled away by the burial party to 'permit access of larger pieces of furniture' into the tomb. The steps, originally stone, were reinstated in plaster by the same burial party. But why would a burial party seal a tomb and then repair a broken stairway before filling in the stairway with rubble behind themselves? This would simply invite others to use the steps in the future, to gain access to a solid wall. The 6 and the 16 are astronomically significant; $6 \times 16 = 96$, the number of magnetic cycles in one sunspot cycle.

999 in the tomb of Viracocha Pachacamac

Figure A14. The coffin lid was tied down by nine copper straps along each edge (9, 9, 9, 9), a number unique to the Supergods. The vertical edges, down each corner, likewise carried the same number of straps (9, 9, 9). He was accompanied by eight others, nine (9) in all. This was no ordinary man. Like the other two sun-kings, Lord Pacal of Mexico (9, 9, 9, 9) and Tutankhamun (9, 9, 9, 9) of Egypt, this man was a Supergod, later revered by the Incas.



APPENDIX TWO

The 999 Message of Viracocha Pachacamac

Figure A15. The lid of the coffin of Viracocha Pachacamac was tied to the sides by three sets of copper straps (3, 3, 3), 9 in all, along each side (9, 9, 9, 9). The corners were likewise tied together, and to the floor of the coffin, with the same number of straps, 9 at each corner (9, 9, 9, 9). The tomb was the final resting place of the Viracocha Pachacamac and 8 companions, 9 in all. The corner brackets of the King of Hochdorf's carriage were pinned to the carriage platform by 9 nails (9, 9, 9, 9) and 9 dinner plates were stored on the carriage.

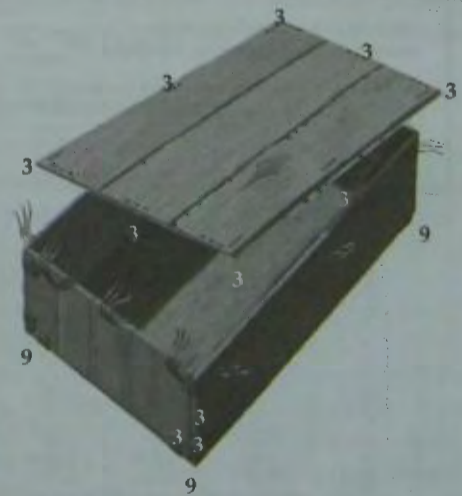

The 999 Message of Tutankhamun



Figure A16. Door seals and object seals from the tomb of Tutankhamun showing the so-called 'prisoners', groups of 9 individuals (9, 9, 9, 9) bound by rope around the neck and arms. Each rope terminates with a lotus flower, the epitome of sun worship, suggesting that the 'prisoners' were in 'divine captivity' on earth. [The taking of prisoners was also a metaphor for 'thou shalt not kill']. Tutankhamun was also buried in 9 coffins, one inside the other.

How Mayan Calendar Cycles Were Encoded into the Pyramid

Number of temple inscriptions

$$620 - 260 \text{ equals } 620$$

Anagram for

Sunspot cycle marker pegs on decoded tomb lid

Calendar cycles of the Maya	144,000	7,200	360	260	20
-----------------------------	---------	-------	-----	-----	----

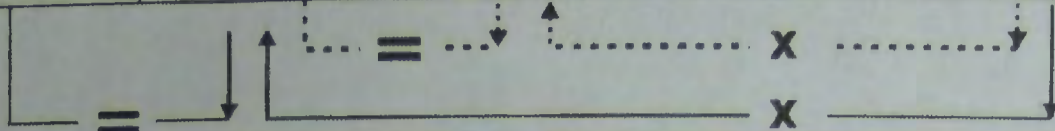

Decoding the clues of the Pyramid and Temple of Inscriptions

1	Pearl in seashell	1	Female skeleton in antechamber	1	Single long bead on necklace	1	Single long bead on necklace	1	Single long bead on necklace
2	Holes in paving slab	2	Holes in paving slab	2	Holes in paving slab	2	Holes in paving slab	2	Plaster heads on tomb floor
3	Clay plates in stone chest	3	Red shells in stone chest	3	-sided tomb door	3	Jade beads (1 in each hand, 1 in mouth)	3	-tiered jade necklace
4	Steps down into tomb	4	Jade rings on left hand	4	Jade rings on right hand	4	Sets of holes in paving slab	4	Cylindrical plugs in sarcophagus
5	Pyramid stairway landings	5	Temple doorways	5	Male skeletons	5	Ceiling beams	5	Sarcophagus sides
6	Temple pillars	6	Sides to tomb lid	missing		missing		missing	
missing		7	Necklace beads	+	= 13	+	= 13	+	= 13
+	= 15	8	Dash-dot beads	8	Dash-dot beads	8	Dash-dot beads	8	Dash-dot beads
8	Necklace beads	8	Dash-dot beads	8	Dash-dot beads	8	Dash-dot beads	8	Dash-dot beads
9	Bottom steps of pyramid	9	Pyramid levels	9	Top steps of pyramid	9	Lords painted on tomb walls	9 / 9*	Codes on left / right sides of lid

Decoding in relation to calendar cycles used by the Maya

$$9 \times 144,000 + 9 \times 7,200 + 9 \times 360 + 9 \times 260 + 9 \times 20 = 1,366,560 \text{ days}$$

Figure A17. Lord Pacal encoded the number of the Supergods 9, 9, 9, 9, 9 into his treasures in the Temple of Inscriptions, Palenque. The number of objects in the tomb cleverly construct a numerical matrix that conceals information: 9 multiplied by the Mayan calendar cycles of time, in days, amounts to 1,366,560 days; the 'Birth of Venus' for the Maya. Moreover, 1 + 3 + 3 + 6 + 6 + 5 + 6 + 0 = 9, the number of a Supergod. They were attempting to convey the fact that Lord Pacal was the spiritual 'rebirth of Venus' (Jesus).

The 9 9 9 Message of Viracocha Pachacamac

Figure A15. The lid of the coffin of Viracocha Pachacamac was tied to the sides by three sets of copper straps (3, 3, 3), 9 in all, along each side (9, 9, 9, 9). The corners were likewise tied together, and to the floor of the coffin, with the same number of straps, 9 at each corner (9, 9, 9, 9). The tomb was the final resting place of the Viracocha Pachacamac and 8 companions, 9 in all. The corner brackets of the King of Hochdorfs' carriage were pinned to the carriage platform by 9 nails (9, 9, 9, 9) and 9 dinner plates were stored on the carriage.

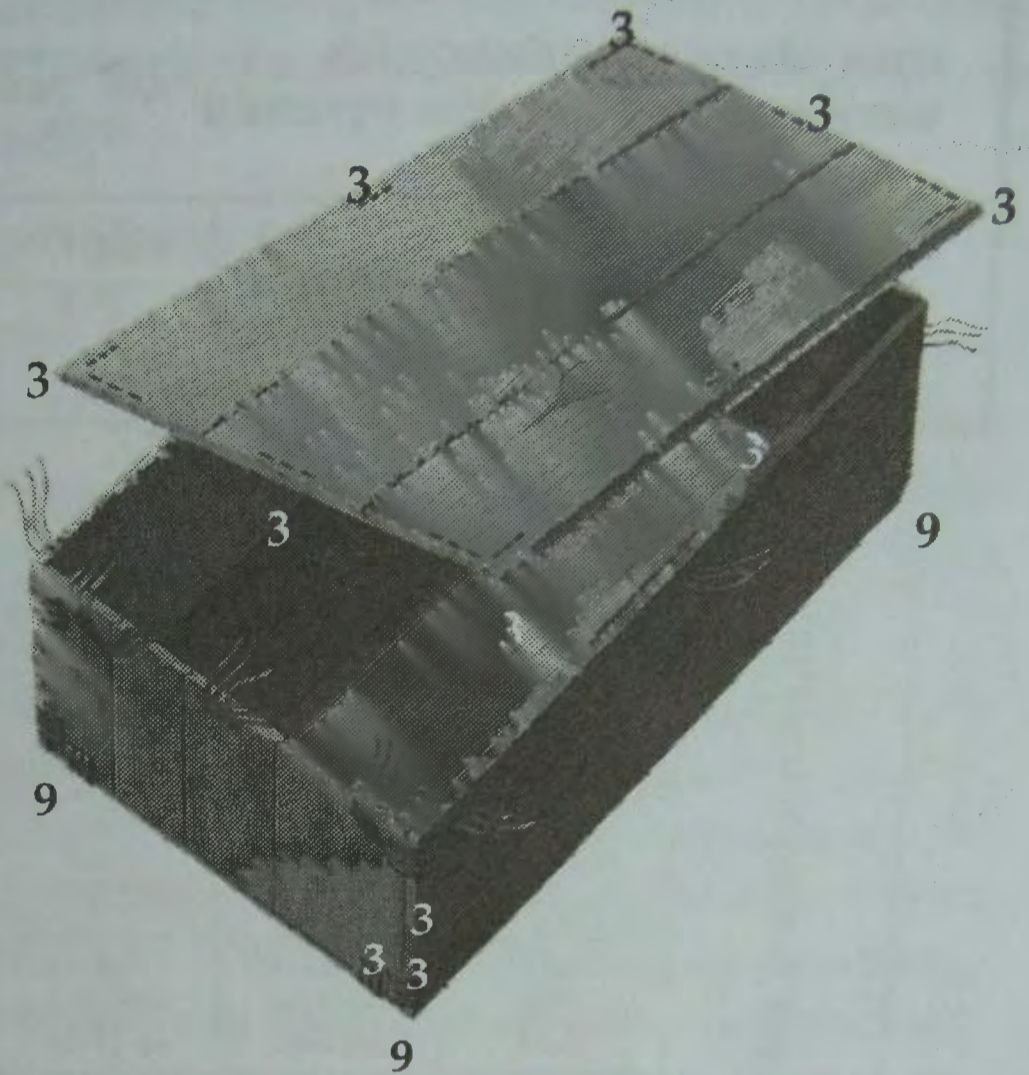

The 9 9 9 Message of Tutankhamun



Figure A16. Door seals and object seals from the tomb of Tutankhamun showing the so-called 'prisoners', groups of 9 individuals (9, 9, 9, 9, 9) bound by rope around the neck and arms. Each rope terminates with a lotus flower, the epitome of sun worship, suggesting that the 'prisoners' were in 'divine captivity' on earth. [The taking of prisoners was also a metaphor for 'thou shall not kill']. Tutankhamun was also buried in 9 coffins, one inside the other.

How Maya calendar cycles were encoded into the Pyramid

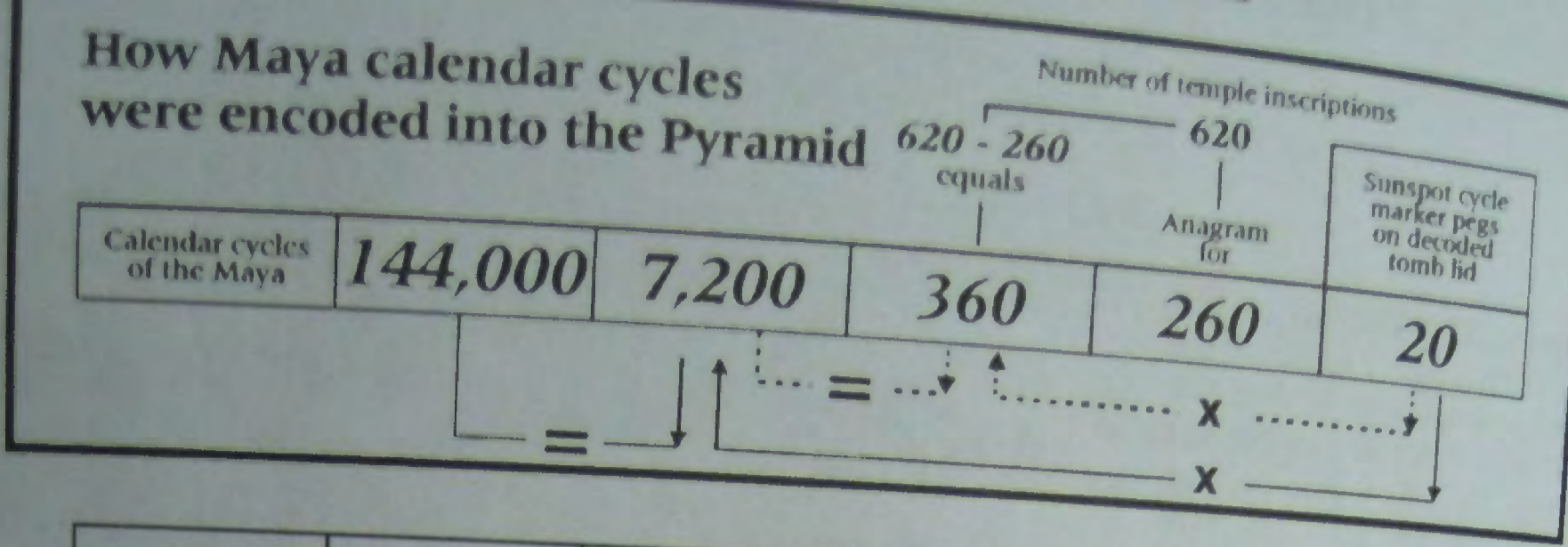













Decoding the clues of the Pyramid and Temple of Inscriptions	1	1	1	1	1
	Pearl in seashell	Female skeleton in antechamber	Single long bead on necklace	Single long bead on necklace	Single long bead on necklace
	2	2	2	2	2
	Holes in paving slab	Holes in paving slab	Holes in paving slab	Holes in paving slab	Plaster heads on tomb floor
	3	3	3	3	3
	Clay plates in stone chest	Red shells in stone chest	-sided tomb door	Jade beads (1 in each hand, 1 in mouth)	-tiered jade necklace
	4	4	4	4	4
	Steps down into tomb	Jade rings on left hand	Jade rings on right hand	Sets of holes in paving slab	Cylindrical plugs in sarcophagus
	5	5	5	5	5
	Pyramid stairway landings	Temple doorways	Male skeletons	Ceiling beams	Sarcophagus sides
6	6	missing	missing	missing	
Temple pillars	Sides to tomb lid				
missing	7	+	+	+	
	Necklace beads	 = 13	 = 13	 = 13	
+	8	8	8	8	
 = 15	Dash-dot beads	Dash-dot beads	Dash-dot beads	Dash-dot beads	
Necklace beads					
9	9	9	9	9 / 9*	
Bottom steps of pyramid	Pyramid levels	Top steps of pyramid	Lords painted on tomb walls	Codes on left / right sides of lid	
Decoding in relation to calendar cycles used by the Maya	$9 \times 144,000 + 9 \times 7,200 + 9 \times 360 + 9 \times 260 + 9 \times 20$ $= 1,366,560 \text{ days}$				

Figure A17. Lord Pacal encoded the number of the Supergods 9, 9, 9, 9, 9 into his treasures in the Temple of Inscriptions, Palenque. The number of objects in the tomb cleverly construct a numerical matrix that conceals information; 9 multiplied by the Maya calendar cycles of time, in days, amounts to 1,366,560 days; the 'Birth of Venus' for the Maya. Moreover, 1 + 3 + 3 + 6 + 6 + 5 + 6 + 0 = 9, the number of a Supergod. They were attempting to convey the fact that Lord Pacal was the spiritual 'rebirth of Venus' (Jesus).

The 999 Message of Lord Pacal

How Maya calendar cycles were encoded into the Pyramid

Number of temple inscriptions
 620 - 260 equals 360
 Anagram for

Sunspot cycle marker pegs on decoded tomb lid

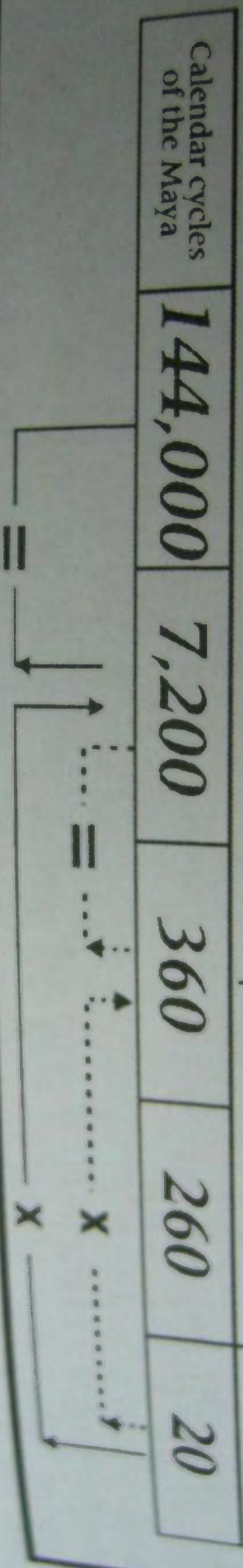

and Temple of Inscriptions

1	1	1	1	1	1
Pearl in seashell	Female skeleton in antechamber	Single long bead on necklace	Single long bead on necklace	Single long bead on necklace	Single long bead on necklace
2	2	2	2	2	2
Holes in paving slab	Holes in paving slab	Holes in paving slab	Holes in paving slab	Holes in paving slab	Plaster beads on tomb floor
3	3	3	3	3	3
Clay plates in stone chest	Red shells in stone chest	slanted round discs	Jade beads (1 in each hand)	round jade necklaces	
4	4	4	4	4	4
Steps down into tomb	Jade rings on left hand	Jade rings on right hand	sets of beads in paving slab	Cylindrical rings in sarcophagus	

go to Hell, it simply means that bad souls return to the carbon-based Earth, which is Hell. This in turn means that all of the world's religions explicitly recognise the reincarnation process.

But surely, by sacrificing himself in such a way, God has not grown, he has reduced in size—by 5%.

The Mechanism of Soul Transmigration

In the beginning, when God sacrificed (say) 5% of himself, the energy exploded with what physicists today refer to as the 'big bang'. Time began when the Universe began, things (events) began to happen (transpire): some things before other things and some things after other things, unlike previously when the only thing that existed was light.

With time, evolution of species began. Human bodies evolved. Brains evolved. In the human womb, the heart pumps blood around the body and the brain becomes electrically active. The voltage of the brain, being opposite to the voltage of God, attracts more electromagnetic energy (imagine a bubble of electromagnetic energy) directly from God as it develops in the womb. This energy, the soul, attaches to the body and stays with the body until the voltage of the physical body falls to a lower value, when it is too weak, too sick, to hold on to it. In between times (during the lifetime of an individual on Earth) the voltage of the soul (when it is entombed within the body) is able to either increase or decrease.

Humans are composed of the physical body; the soul (the spiritual body); the mind (the intellectual body); and the heart (the emotional body). These four 'bodies' live in distinct worlds which conform to different rules. For example, in the physical world, if I have one dollar and you have one dollar and we exchange them, then we each finish up with only one dollar, which seems to prove, at least in the physical world, that we cannot get something for nothing. But the other worlds are not the same. For example, in the intellectual world, if I have one idea and you also have one idea and we exchange them, then we both finish up with two ideas. In the intellectual world we can double our intellectual wealth at no cost. It seems that in the emotional world, if I love you, then my soul voltage will grow. If my soul voltage grows, then when it leaves my body it will be attracted back to God and God will grow. Conversely,

The Three Worlds

Figure A18. Some of the stories from the Amazing Lid of Palenque explain that the souls of those who die at childbirth, in battle and in sacrifice migrate to the Paradies, various destinations of the dead, to enjoy heavenly bliss, presumably before proceeding to the God World, the place where God resides. Some pictures show how the soul leaves the body for either rebirth in the stars (the heavens and the God World) or rebirth on Earth (reincarnation). Others describe the journey of the soul into the underworld or through purgatory, the place where the heart is purged of sin. The Maya also believed that there were nine levels to the underworld through which the departed soul had to travel prior to moving on, either to the God World or to reincarnation on Earth. (It seems that perfectly purified souls fast-track through the Soul World to the God World and that impure souls suffer in the underworld (purgatory) for their earthly sins before acquiring the energy to reincarnate on Earth for another chance of soul purification.)

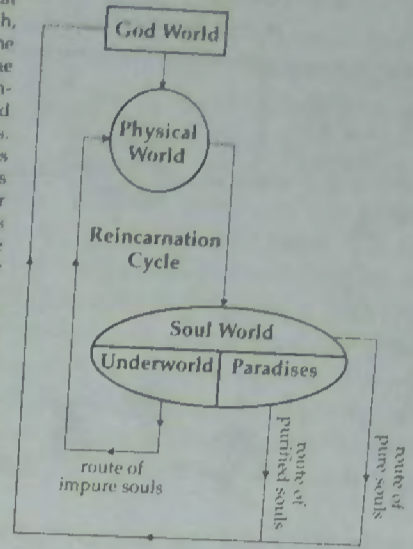

The General Theory of Existence

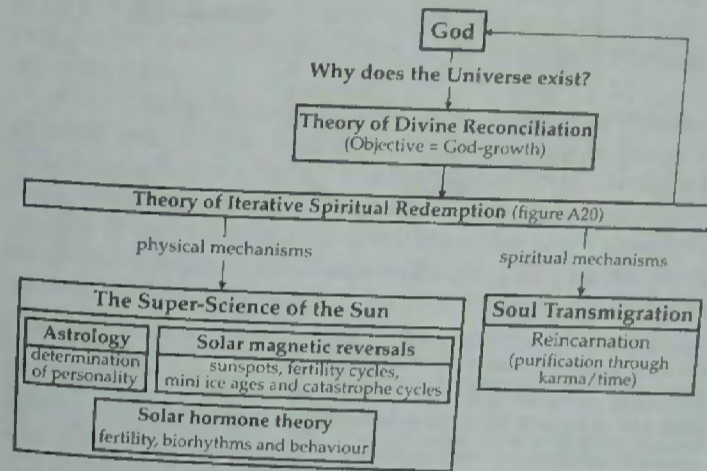
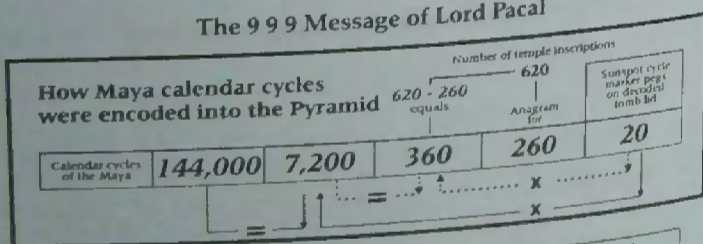

Figure A19. Treasures from the tombs of the sun-kings suggest that the purpose of the Universe is to accommodate God-growth (in accordance with the Theory of Divine Reconciliation, as detailed in the main text). Figure A20 resolves the Theory of Divine Reconciliation and the Three Worlds hypothesis into a working model.

THE CELTIC CHRONICLES

The 9 9 9 Message of Lord Pacal



Decoding the clues of the Pyramid and Temple of Inscriptions

1	1 Pearl in seashell	1	1 Female skeleton in antechamber	1	1 Single long lead on necklace	1	1 Single long lead on necklace	1	1 Single long lead on necklace
2	2 Holes in paving slab	2	2 Holes in paving slab	2	2 Holes in paving slab	2	2 Holes in paving slab	2	2 Plaster beads on tomb floor
3	3 Clay plates in stone chest	3	3 Red shells in stone chest	3	3 Sided necklaces	3	3 Jade beads (1 in each lead 1 in mouth)	3	3 Layered jade necklaces
4	4 Serpents down stairs tomb	4	4 Jade rings on left hand	4	4 Jade rings on right hand	4	4 Sets of holes in paving slab	4	4 Cylindrical plugs in sarcophagus
5	5 Pyramid passway landings	5	5 Temple doorways	5	5 Male skeletons	5	5 Carving for axis	5	5 Sarcophagus sides
6	6 Temple pillars	6	6 Sides to tomb lid	6	6	6	6	6	6
7	7	7	7	7	7	7	7	7	7
8	8	8	8	8	8	8	8	8	8
9	9	9	9	9	9	9	9	9	9

144,000 + 7,200 + 360 + 260 + 20 = 1,366,560 days

Figure A17. Lord Pacal encoded the numbers of the Superpyramid 9 9 9 9 into the treasures in the Temple of Inscriptions, Palenque. The number of objects in the tomb cleverly constructed a numerical matrix that conceals information 9 multiplied by the Maya calendar system of time in days, amounts to 1,366,560 days, the Birth of Venus for the Maya. Moreover, 1 + 2 + 3 + 4 + 5 + 6 + 7 + 8 + 9 = 45, the number of a Supergrid. They were attempting to convey the call that Lord Pacal was the spiritual rebirth of Venus (Jesus).

APPENDIX TWO

return to the carbon-based Earth, which is Hell. This in turn means that all of the world's religions explicitly recognise the reincarnation process.

But surely, by sacrificing himself in such a way, God has not grown, he has reduced in size—by 5%.

The Mechanism of Soul Transmigration

In the beginning, when God sacrificed (say) 5% of himself, the energy exploded with what physicists today refer to as the 'big bang'. Time began when the Universe began, things (events) began to happen (transpire): some things before other things and some things after other things, unlike previously when the only thing that existed was light.

With time, evolution of species began. Human bodies evolved. Brains evolved. In the human womb, the heart pumps blood around the body of the foetus and the brain of the foetus becomes electrically active. The voltage of the brain, being opposite to the voltage of God, attracts more electromagnetic energy (imagine a bubble of electromagnetic energy) directly from God as it develops in the womb. This energy, the soul, attaches to the body and stays with the body until the voltage of the physical body falls to a lower value, when it is too weak, too sick, to hold on to it. In between times (during the lifetime of an individual on Earth) the voltage of the soul (when it is entombed within the body) is able to either increase or decrease.

Humans comprise of the physical body; the soul (the spiritual body); the mind (the intellectual body); and the heart (the emotional body). These four 'bodies' live in distinct worlds which conform to different rules. For example, in the physical world, if I have £1 and you have £1 and we exchange them then we each finish up with only £1, which seems to prove, at least in the physical world, that we cannot get something for nothing. But the other worlds are not the same. For example in the intellectual world if I have one idea and you also have one idea and we exchange them, then we both finish up with two ideas. In the intellectual world we can double our intellectual wealth at no cost. It seems that in the emotional world, if I love you then my soul voltage will grow. If my soul voltage grows then when it leaves my body it will be attracted back to God and God will grow. Conversely, if I hate you then my soul voltage will fall, and I will return to Earth to a lower voltage body. The

go to Hell, it simply means that bad souls return to the carbon-based Earth, which is Hell. This in turn means that all of the world's religions explicitly recognise the reincarnation process.

But surely, by sacrificing himself in such a way, God has not grown, he has reduced in size—by 5%.

The Mechanism of Soul Transmigration

In the beginning, when God sacrificed (say) 5% of himself, the energy exploded with what physicists today refer to as the 'big bang'. Time began when the Universe began, things (events) began to happen (transpire): some things before other things and some things after other things, unlike previously when the only thing that existed was light.

With time, evolution of species began. Human bodies evolved. Brains evolved. In the human womb, the heart pumps blood around the body and the brain becomes electrically active. The voltage of the brain, being opposite to the voltage of God, attracts more electromagnetic energy (imagine a bubble of electromagnetic energy) directly from God as it develops in the womb. This energy, the soul, attaches to the body and stays with the body until the voltage of the physical body falls to a lower value, when it is too weak, too sick, to hold on to it. In between times (during the lifetime of an individual on Earth) the voltage of the soul (when it is entombed within the body) is able to either increase or decrease.

Humans are composed of the physical body; the soul (the spiritual body); the mind (the intellectual body); and the heart (the emotional body). These four 'bodies' live in distinct worlds which conform to different rules. For example, in the physical world, if I have one dollar and you have one dollar and we exchange them, then we each finish up with only one dollar, which seems to prove, at least in the physical world, that we cannot get something for nothing. But the other worlds are not the same. For example, in the intellectual world, if I have one idea and you also have one idea and we exchange them, then we both finish up with two ideas. In the intellectual world we can double our intellectual wealth at no cost. It seems that in the emotional world, if I love you, then my soul voltage will grow. If my soul voltage grows, then when it leaves my body it will be attracted back to God and God will grow. Conversely,

Figure A18. Some of the stories from the Amazing Lid of Palenque explain that the souls of those who die at childbirth, in battle and in sacrifice migrate to the Paradies, various destinations of the dead, to enjoy heavenly bliss, presumably before proceeding to the God World, the place where God resides. Some pictures show how the soul leaves the body for either rebirth in the stars (the heavens and the God World) or rebirth on Earth (reincarnation). Others describe the journey of the soul into the underworld or through purgatory, the place where the heart is purged of sin. The Maya also believed that there were nine levels to the underworld through which the departed soul had to travel prior to moving on, either to the God World or to reincarnation on Earth. (It seems that perfectly purified souls fast-track through the Soul World to the God World and that impure souls suffer in the underworld (purgatory) for their earthly sins before acquiring the energy to reincarnate on Earth for another chance of soul purification.)

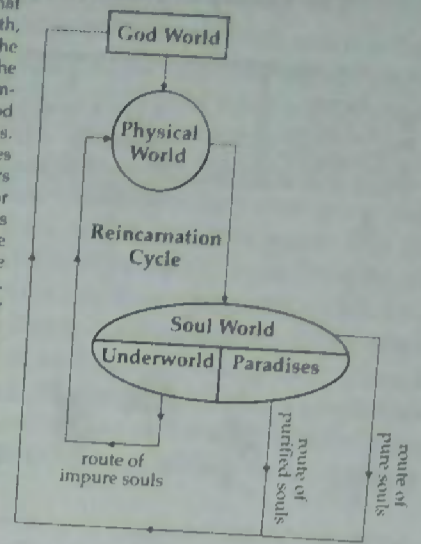

The General Theory of Existence

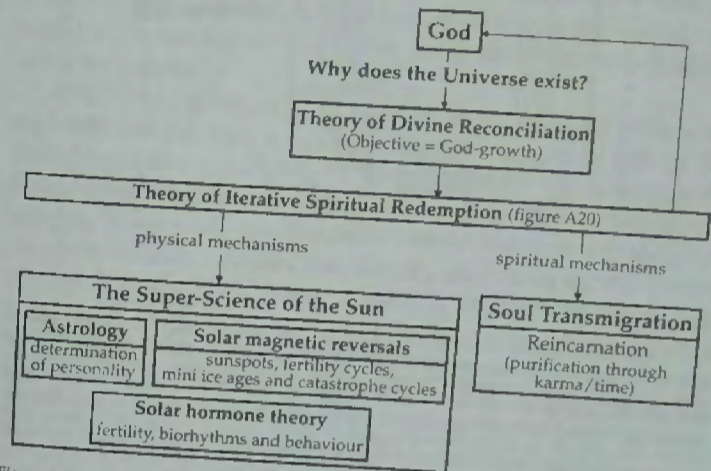
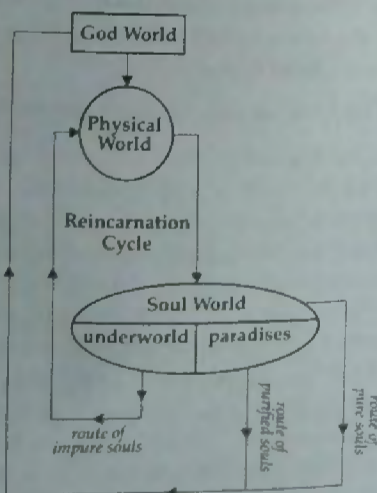

Figure A19. Treasures from the tombs of the sun-kings suggest that the purpose of the Universe is to accommodate God-growth (in accordance with the Theory of Divine Reconciliation, as detailed in the main text). Figure A20 resolves the Theory of Divine Reconciliation and the Three Worlds hypothesis into a working model.

The Three Worlds

Figure A18. Some of the stories from the Amazing Lid of Palenque explain that the souls of those who die at childbirth, in battle and in sacrifice migrate to the Paradies, various destinations of the dead, to enjoy heavenly bliss, presumably before proceeding to the God World, the place where God resides. Some pictures show how the soul leaves the body for either rebirth in the stars (the heavens and the God World) or rebirth on Earth (reincarnation). Others describe the journey of the soul into the underworld or through purgatory, the place where the heart is purged of sin. The Mayas also believed that there were nine levels to the underworld through which the departed soul had to travel prior to moving on, either to the God World or to reincarnation on Earth. (It seems that perfectly purified souls fast-track through the Soul World to the God World and that impure souls suffer in the underworld (purgatory) for their earthly sins before acquiring the energy to reincarnate on Earth for another chance of soul purification.)



The General Theory of Existence

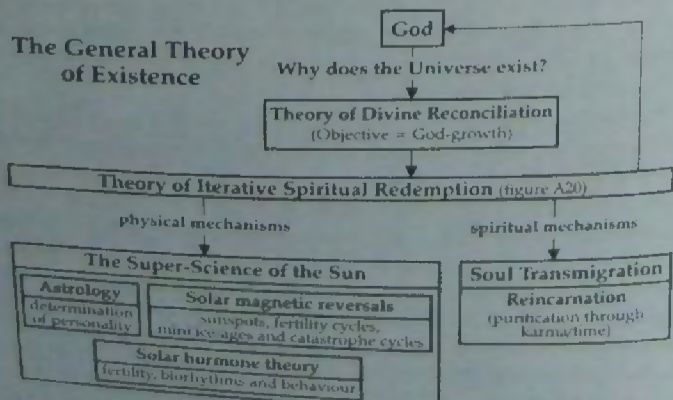

Figure A19. Treasures from the tombs of the sun-kings suggest that the purpose of the Universe is to accommodate God-growth (in accordance with the Theory of Divine Reconciliation, as detailed in the main text). Figure A20 resolves the Theory of Divine Reconciliation and the Three Worlds hypothesis into a working model.

The Theory of Iterative Spiritual Redemption

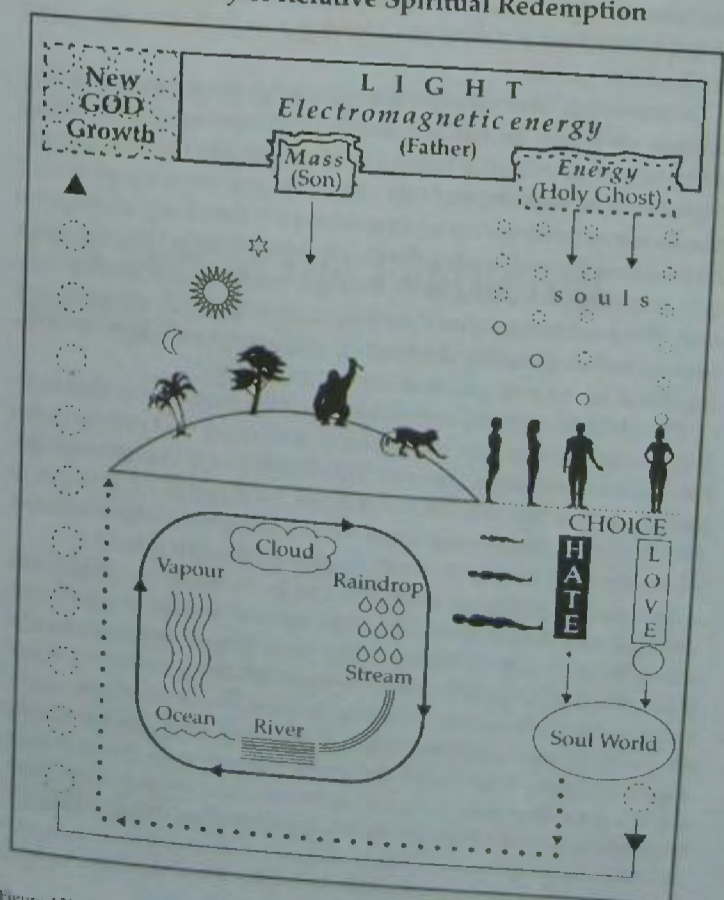

Figure A20. The scriptures tell us that God is Light. Light is electromagnetic energy. Einstein tells us that $E = mc^2$, which means that God is Light. Light is electromagnetic energy. Einstein converted, is proportional to the speed of light squared (C^2). This suggests that in the beginning God sacrificed a part of himself, creating the physical Universe (the Son). Physical bodies then evolved to attract discrete packets of electromagnetic energy (souls) away from the source of energy (God). The journey of the soul is analogous to that of a raindrop, which is reborn many times. Purification comes through love and sacrifice. Purified souls return to the creator. As a result, the creator grows. Bad souls return to earth, attempting purification once again.

The Theory of Iterative Spiritual Redemption

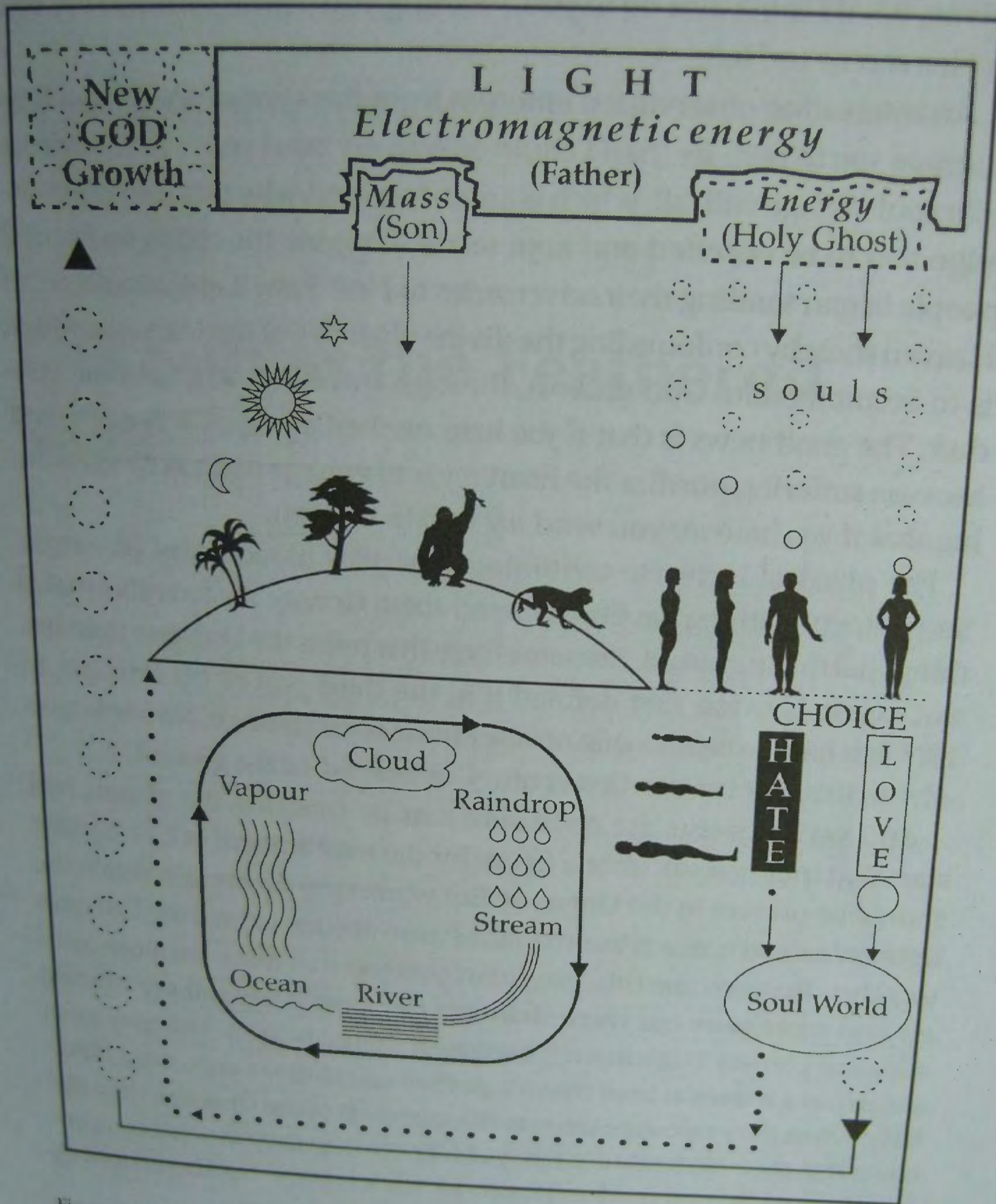
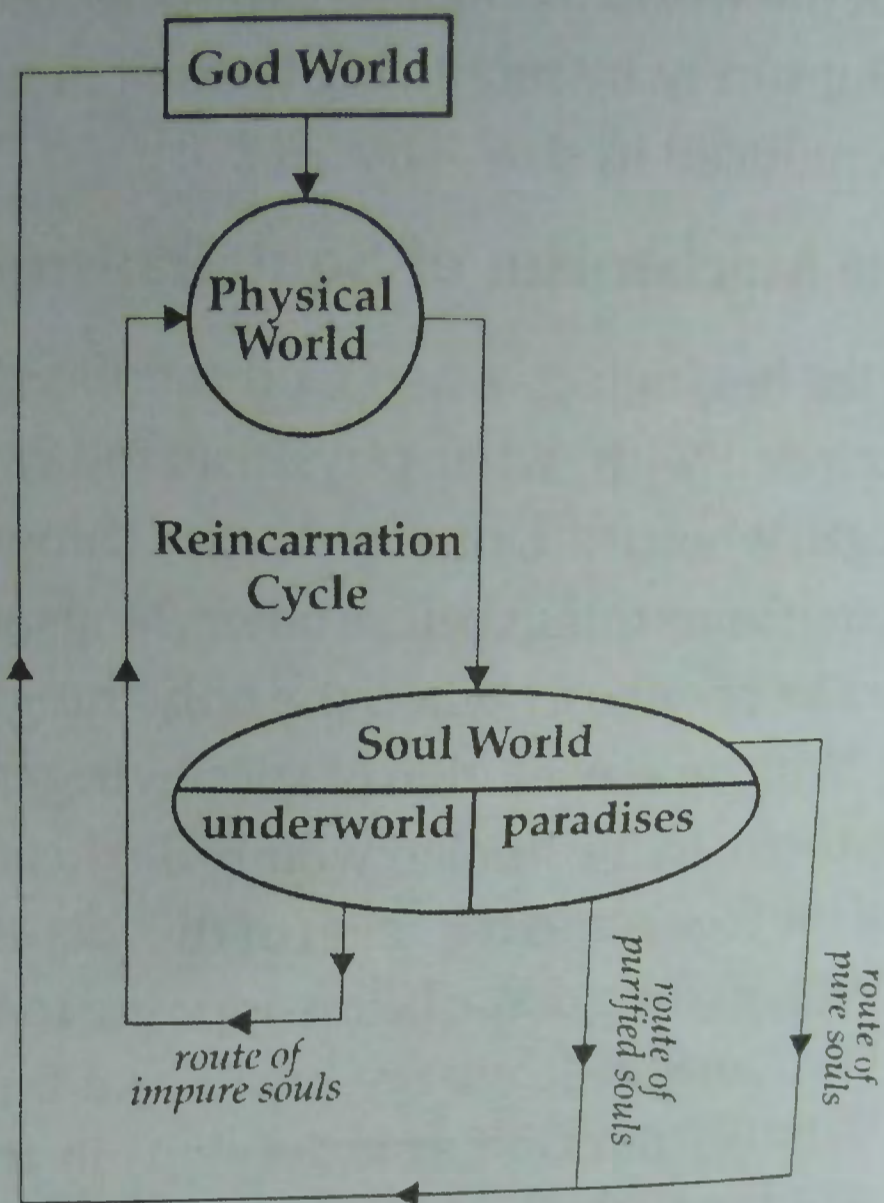

Figure A20. The scriptures tell us that God is Light. Light is electromagnetic energy. Einstein tells us that $E = mc^2$, which means that energy (E) can be converted into physical mass (m) and mass can be converted into energy. The equation tells us that the release of energy, when mass is converted, is proportional to the speed of light squared (C^2). This suggests that in the beginning God sacrificed a part of himself, creating the physical Universe (the Son). Physical bodies then evolved to attract discrete packets of electromagnetic energy (souls) away from the source of energy (God). The journey of the soul is analogous to that of a raindrop, which is reborn many times. Purification comes through love and sacrifice. Purified souls return to the creator. As a result, the creator grows. Bad souls return to earth, attempting purification once again.

The Three Worlds

Figure A18. Some of the stories from the Amazing Lid of Palenque explain that the souls of those who die at childbirth, in battle and in sacrifice migrate to the Paradieses, various destinations of the dead, to enjoy heavenly bliss, presumably before proceeding to the God World, the place where God resides. Some pictures show how the soul leaves the body for either rebirth in the stars (the heavens and the God World) or rebirth on Earth (reincarnation). Others describe the journey of the soul into the underworld or through purgatory, the place where the heart is purged of sin. The Mayas also believed that there were nine levels to the underworld through which the departed soul had to travel prior to moving-on, either to the God World or to reincarnation on Earth. (It seems that perfectly purified souls fast-track through the Soul World to the God World and that impure souls suffer in the underworld (Purgatory) for their Earthly sins before acquiring the energy to reincarnate on Earth for another chance of soul purification.)



The General Theory of Existence

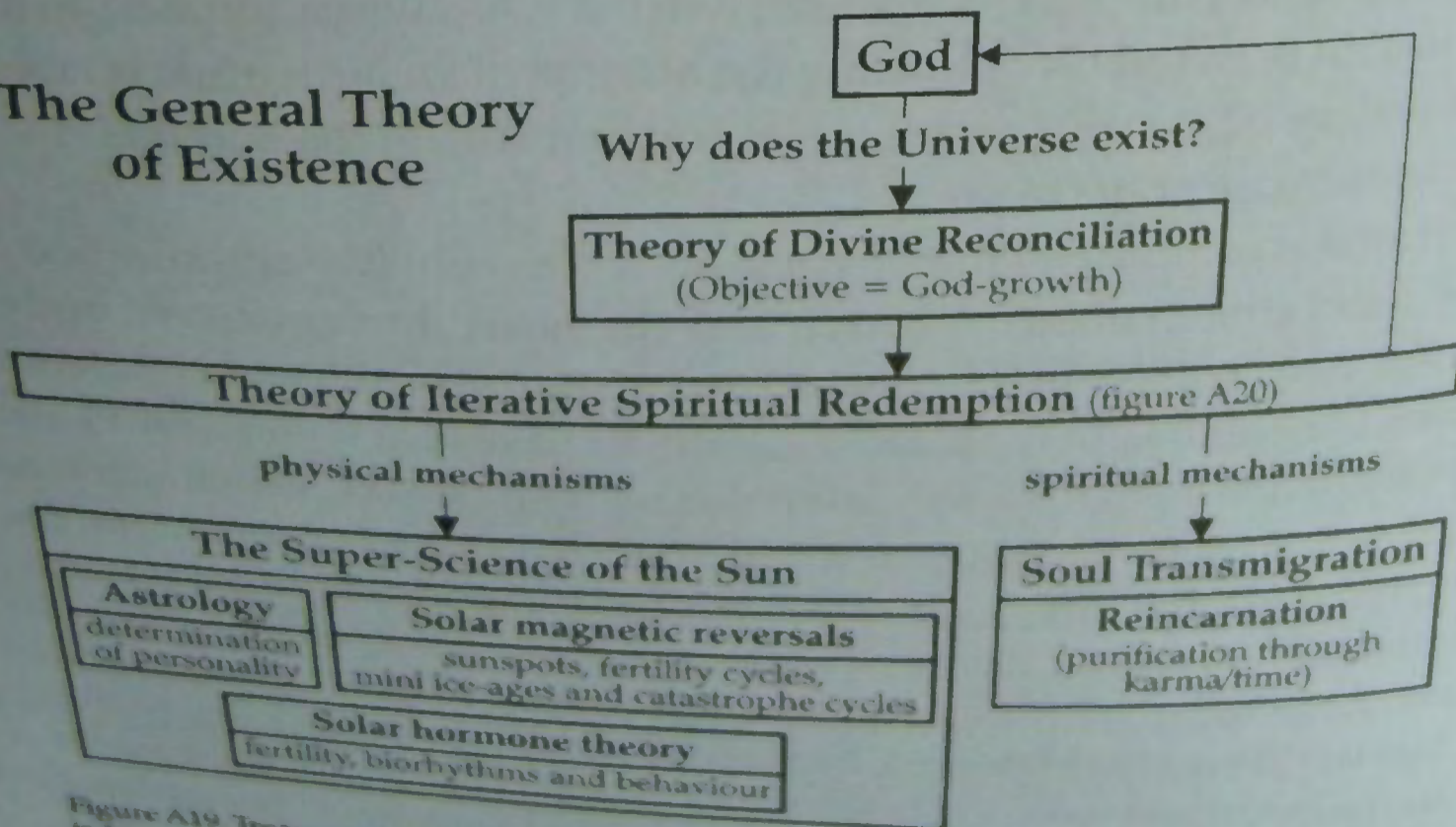
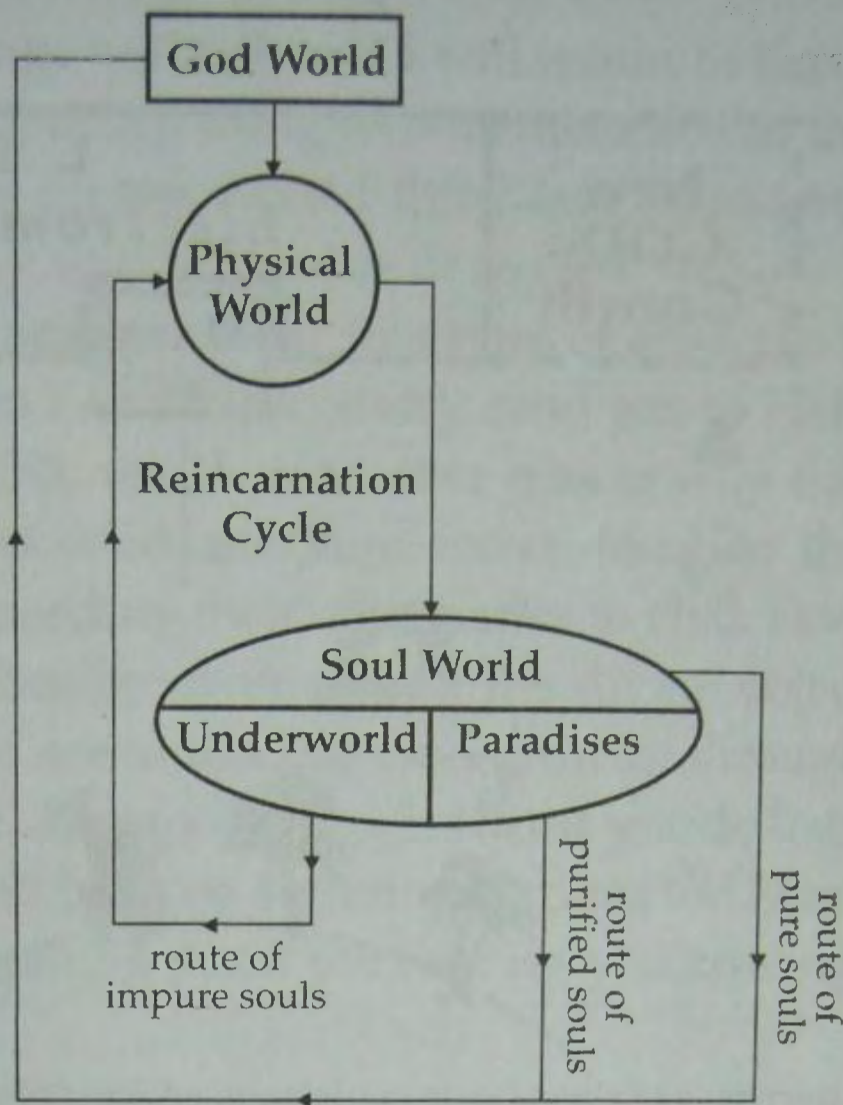

Figure A19. Treasures from the tombs of the sun-kings suggest that the purpose of the Universe is to accommodate God-growth (in accordance with the Theory of Divine Reconciliation, as detailed in the main text). Figure A20 resolves the Theory of Divine Reconciliation and The Three Worlds hypothesis into a working model.

Figure A18. Some of the stories from the Amazing Lid of Palenque explain that the souls of those who die at childbirth, in battle and in sacrifice migrate to the Paradieses, various destinations of the dead, to enjoy heavenly bliss, presumably before proceeding to the God World, the place where God resides. Some pictures show how the soul leaves the body for either rebirth in the stars (the heavens and the God World) or rebirth on Earth (reincarnation). Others describe the journey of the soul into the underworld or through purgatory, the place where the heart is purged of sin. The Maya also believed that there were nine levels to the underworld through which the departed soul had to travel prior to moving on, either to the God World or to reincarnation on Earth. (It seems that perfectly purified souls fast-track through the Soul World to the God World and that impure souls suffer in the underworld (purgatory) for their earthly sins before acquiring the energy to reincarnate on Earth for another chance of soul purification.)



The General Theory of Existence

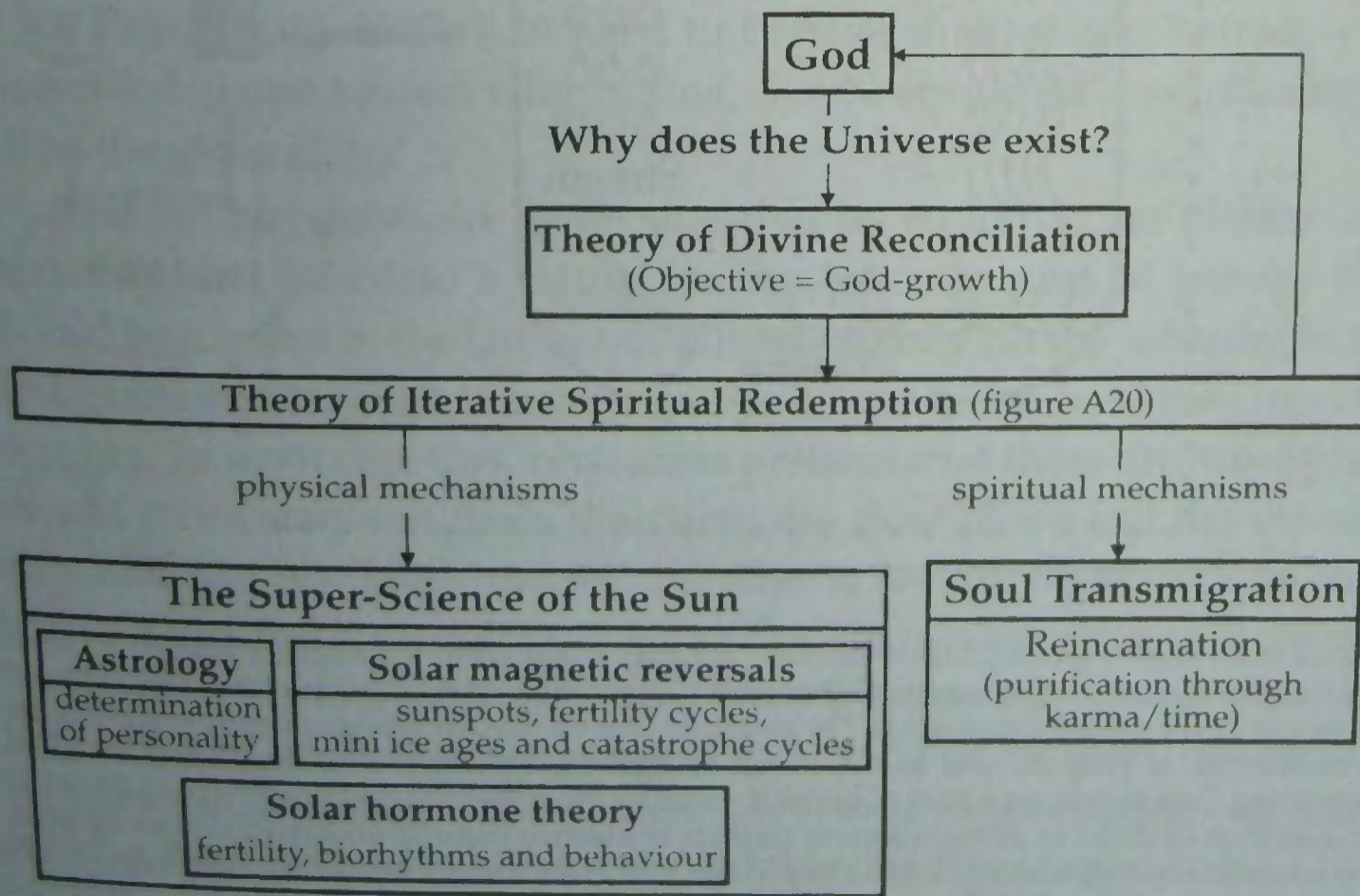

Figure A19. Treasures from the tombs of the sun-kings suggest that the purpose of the Universe is to accommodate God-growth (in accordance with the Theory of Divine Reconciliation, as detailed in the main text). Figure A20 resolves the Theory of Divine Reconciliation and the Three Worlds hypothesis into a working model.

The Theory of Iterative Spiritual Redemption

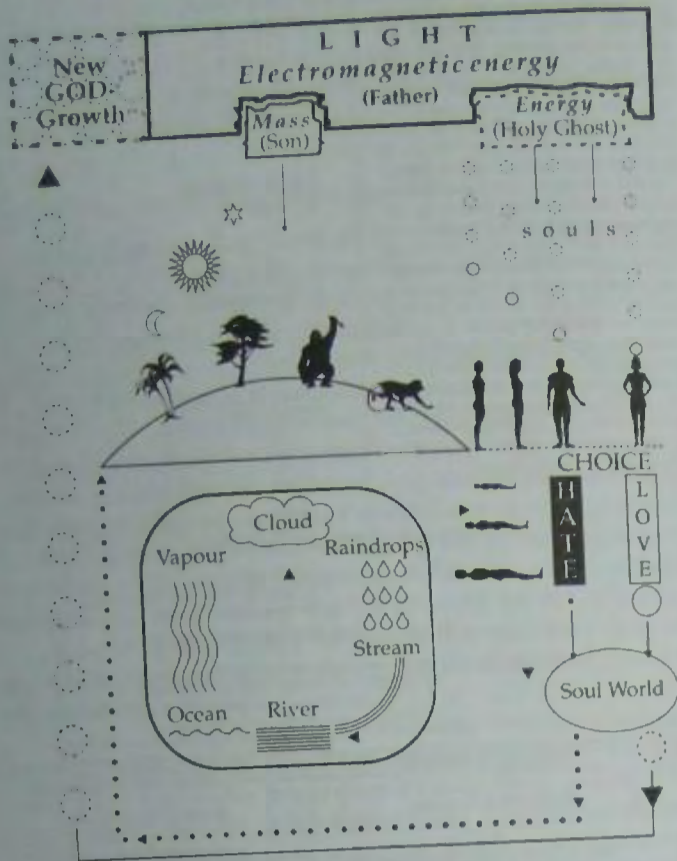

Figure A20. The scriptures tell us that God is Light. Light is electromagnetic energy. Einstein tells us that $E = mc^2$, which means that energy (E) can be converted into physical mass (m) and mass can be converted into energy. The equation tells us that the release of energy, when mass is converted, is proportional to the speed of light squared (c^2). This suggests that in the beginning God sacrificed a part of himself, creating the physical Universe (the Son) away from bodies then evolved to attract discrete packets of electromagnetic energy (souls) away from the source of energy (God). The journey of the soul is analogous to that of a raindrop, which is reborn many times. Purification comes through love and sacrifice. Purified souls return to the creator. As a result, the creator grows. Bad souls return to Earth, attempting purification once again.

if I hate you, then my soul voltage will fall, and I will return to Earth to a lower-voltage body. The important thing to remember is that the destination of my soul depends on me, what I think and do to you. Nothing you can do can send my soul to Heaven or to Hell.

An interesting observation emerges from this type of analysis: if I encourage you to hate me, then I could effectively send you to Hell, because your soul voltage will fall, which is another reason why this sacred knowledge had to be encoded and kept secret. Imagine the chaos on Earth if people began sending their adversaries to Hell. Few, if any, would get to Heaven, thereby confounding the divine objective of the Universe which is to accommodate God-growth, through mankind, as a spiritual conduit. The good news is that if you do hate me, then my heart will suffer and because suffering purifies the heart my soul voltage will increase, meaning that if you hate me, you send my soul to Heaven.

The physical Universe continues to perplex modern-day physicists. Surprisingly, nothing has been learned about gravity, the force that makes things fall to the ground, the same force that holds the Universe together, since Isaac Newton first defined it in the third part of his *Principia*, in 1687. It is hard to believe that no one knows what causes it. No one knows why in this, our twenty-first century, objects fall to the ground.

And yet physicists are quite sure that by counting the planets and stars they can calculate a figure for the total amount of gravity that should be present in the Universe. But when they do the calculation the figure obtained is much less than the figure needed to hold the Universe together. To overcome this, physicists pretend that there are more planets and more stars out there than actually exist. They call the missing stars and planets 'black matter' because it cannot be seen. This may seem absurd, but it does at least mean that their calculations are correct. Similarly, when they calculate the rate of expansion of the Universe they discover that their figures are in fact much lower than they should be, meaning, they argue, that there must also be 'dark energy' out there, making the Universe expand more quickly than it actually does.

It has never occurred to them to consider that 95% of the energy in the Universe, God, did not convert to physical matter when the Universe began or that God might be holding the Universe together.

The Three Worlds

Figure A18. Some of the stories from the Amazing Lid of Palenque explain that the souls of those who die at childbirth, in battle and in sacrifice migrate to the Paradies, various destinations of the dead, to enjoy heavenly bliss, presumably before proceeding to the God World, the place where God resides. Some pictures show how the soul leaves the body for either rebirth in the stars (the heavens and the God World) or rebirth on Earth (reincarnation). Others describe the journey of the soul into the underworld or through purgatory, the place where the heart is purged of sin. The Mayas also believed that there were nine levels to the underworld through which the departed soul had to travel prior to moving-on, either to the God World or to reincarnation on Earth. (It seems that perfectly purified souls fast-track through the Soul World to the God World and that impure souls suffer in the underworld (Purgatory) for their earthly sins before acquiring the energy to reincarnate on Earth for another chance of soul purification.)

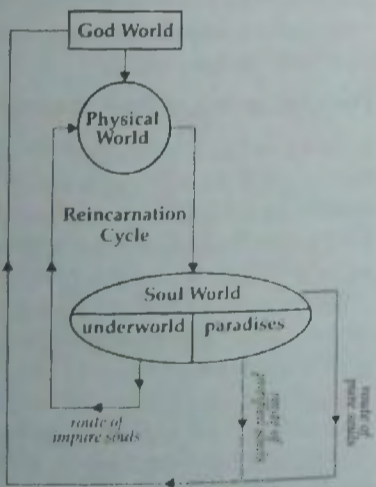

The General Theory of Existence

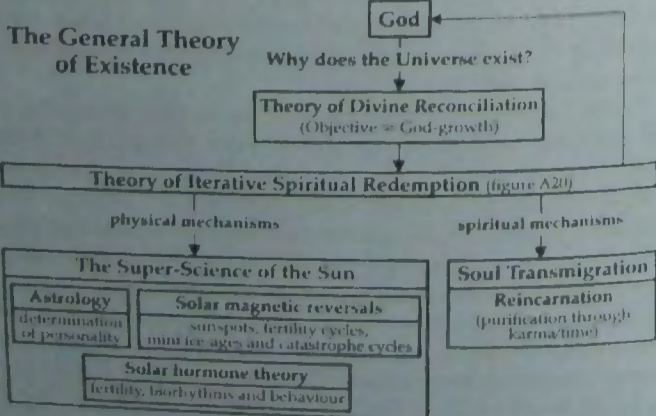

Figure A19. Inscriptions from the tombs of the sun-kings suggest that the purpose of the Universe is to accommodate God-growth (in accordance with the Theory of Divine Reconciliation, as detailed in the main text). Figure A20 resolves the Theory of Divine Reconciliation and the Three Worlds hypothesis into a working model.

The Theory of Iterative Spiritual Redemption

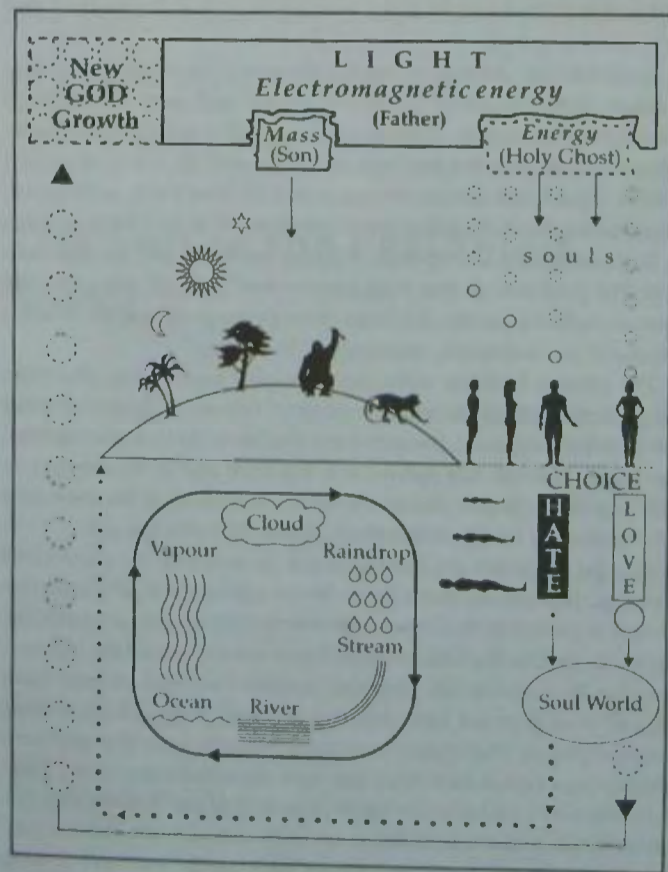

Figure A20. The scriptures tell us that God is Light. Light is electromagnetic energy. Einstein tells us that $E = mc^2$, which means that energy (E) can be converted into physical mass (m) and mass can be converted into energy. The equation tells us that the release of energy, when mass is converted, is proportional to the speed of light squared (c^2). This suggests that in the beginning God sacrificed a part of himself, creating the physical Universe (the Son) away from bodies then evolved to attract discrete packets of electromagnetic energy (souls) away from the source of energy (God). The journey of the soul is analogous to that of a raindrop, which is reborn many times. Purification comes through love and sacrifice. Purified souls return to the creator. As a result, the creator grows. Bad souls return to earth, attempting purification once again.

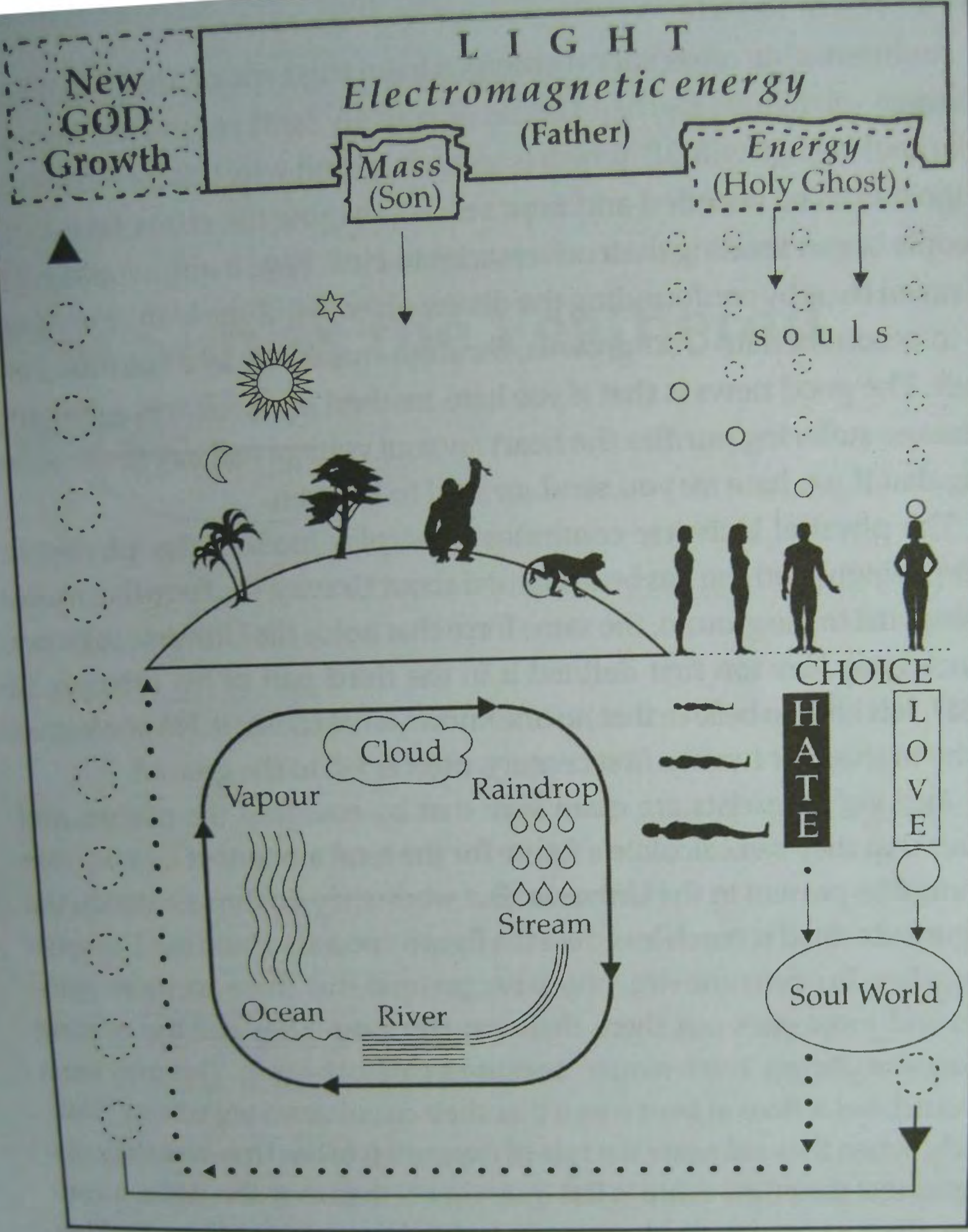

Figure A20. The scriptures tell us that God is Light. Light is electromagnetic energy. Einstein tells us that $E = mc^2$, which means that energy (E) can be converted into physical mass (m) and mass can be converted into energy. The equation tells us that the release of energy, when mass is converted, is proportional to the speed of light squared (C^2). This suggests that in the beginning God sacrificed a part of himself, creating the physical Universe (the Son). Physical bodies then evolved to attract discrete packets of electromagnetic energy (souls) away from the source of energy (God). The journey of the soul is analogous to that of a raindrop, which is reborn many times. Purification comes through love and sacrifice. Purified souls return to the creator. As a result, the creator grows. Bad souls return to earth, attempting purification once again.



The Sun as the Feathered Snake

The Sun as the Feathered Snake

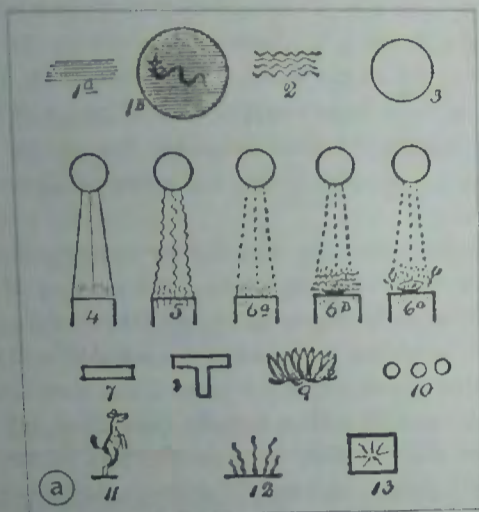

Figure A21. (a) Sketches of the 25,000-year-old lost Tibetan Naacal tablets, made by the explorer James Churchward during his stay in a Tibetan monastery in the 1930s. They show the sinking of the legendary island of Lemuria caused by adverse solar radiation patterns; increased levels of radiation led to the overheating of the landmass, causing the release of subterranean gases and the sinking of the land itself. One of the sketches (labelled as 1^b) shows a feathered snake-like mark across the face of the Sun—the earliest known depiction showing the Sun as the 'feathered snake'.

important thing to remember is that the destination of my soul depends on me, what I think and do to you. Nothing you can do can send my soul to Heaven or to Hell.

An interesting observation emerges from this type of analysis; if I encourage *you* to hate *me* then I could effectively send *you* to Hell, because *your* soul voltage will fall, which is another reason why this sacred knowledge had to be encoded and kept secret. Imagine the chaos on Earth if people began sending their adversaries to Hell. Few, if any, would get to Heaven thereby confounding the divine objective of the Universe which is to accommodate God growth, through mankind, as a spiritual conduit. The good news is that if *you* hate *me* then *my* heart will suffer and because suffering purifies the heart *my* soul voltage will increase; meaning that if *you* hate *me* you send *my* soul to Heaven.

The physical Universe continues to perplex modern-day physicists. Surprisingly, nothing has been learned about Gravity, the force that makes things fall to the ground, the same force that holds the Universe together, since Isaac Newton first defined it in the third part of his *Principia*, in 1687. It is hard to believe that no one knows what causes it. No one knows why in this, our twenty-first century, objects fall to the ground.

And yet physicists are quite sure that by counting the planets and stars that they can calculate a figure for the total amount of Gravity that should be present in the Universe. But when they do the calculation the figure obtained is much less than the figure needed to hold the Universe together. To overcome this, physicists pretend that there are more planets and more stars out there than actually exist. They call the missing stars and planets 'black matter' because it cannot be seen. This may seem absurd, but it does at least mean that their calculations are correct. Similarly, when they calculate the rate of expansion of the Universe they discover that their figures are in fact much lower than they should be, meaning, they argue, that there must also be 'dark energy' out there, making the Universe expand more quickly than it actually does.

It has never occurred to them to consider that 95% of the energy in the Universe, God, did not convert to physical matter when the Universe began or that God might be holding the Universe together.

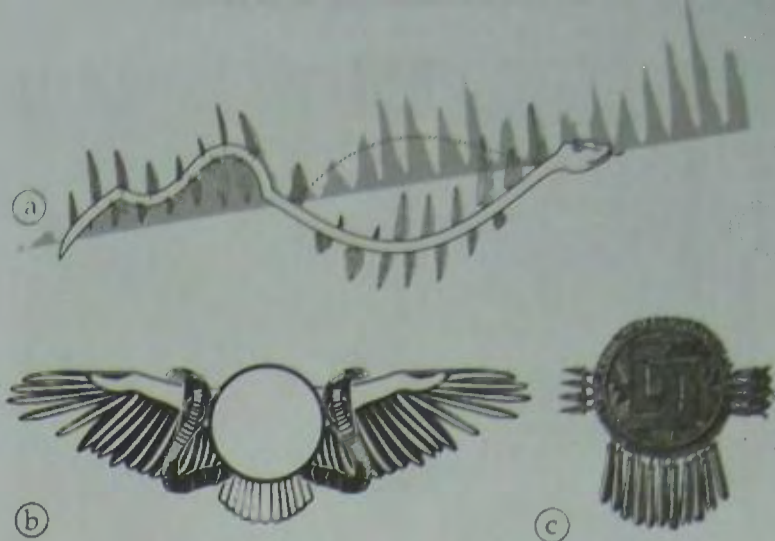

Figure A22. (a) Schematic of the the neutral sheet of the Sun illustrated as a feathered snake. The feathered snake of the Sun was worshipped and depicted in carvings and paintings throughout Egypt (b) and Mexico (c).

Tutankhamun, the Feathered Snake of Egypt



Figure A23. Tutankhamun carried the vulture (feathers) and a snake on his forehead. His beard was fashioned as the body of a snake which ended with the tail feathers of a bird.

APPENDIX THREE

The Sun as the Feathered Snake

The Sun as the Feathered Snake

The Sun as the Feathered Snake

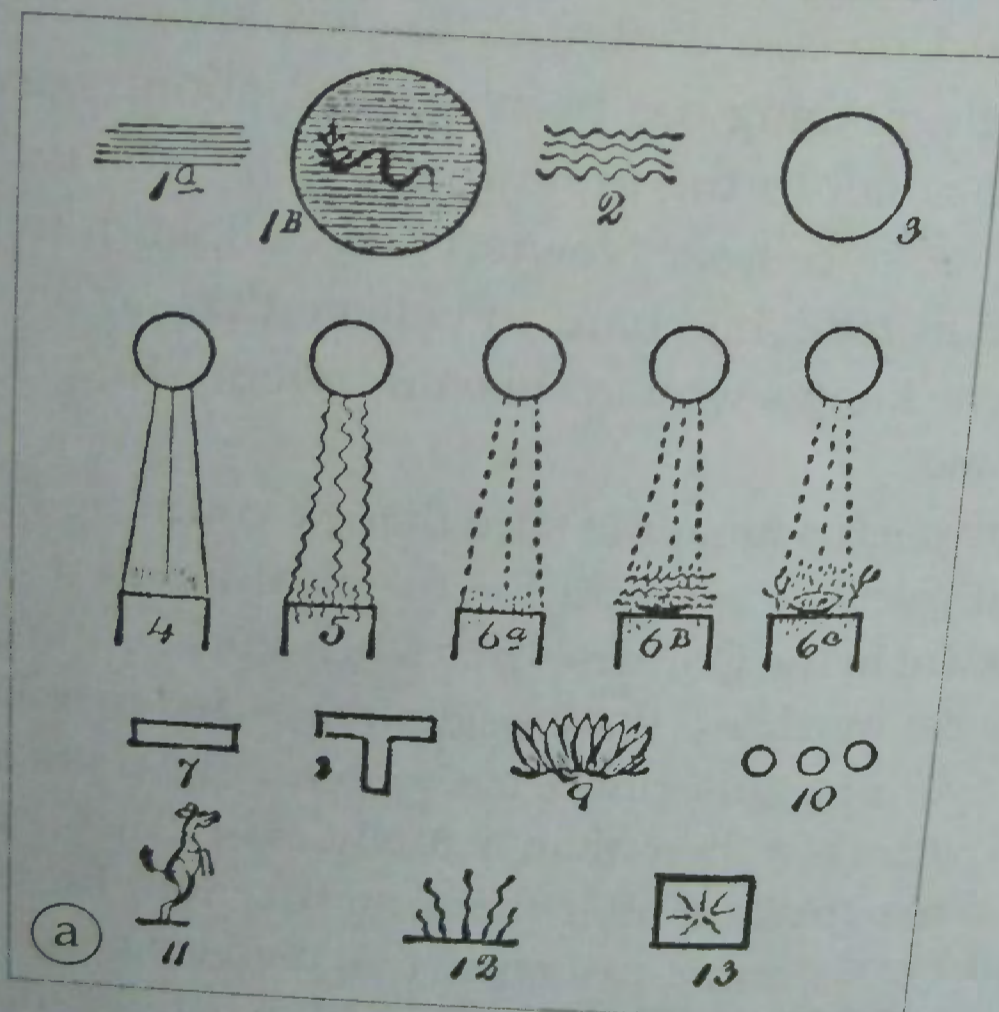
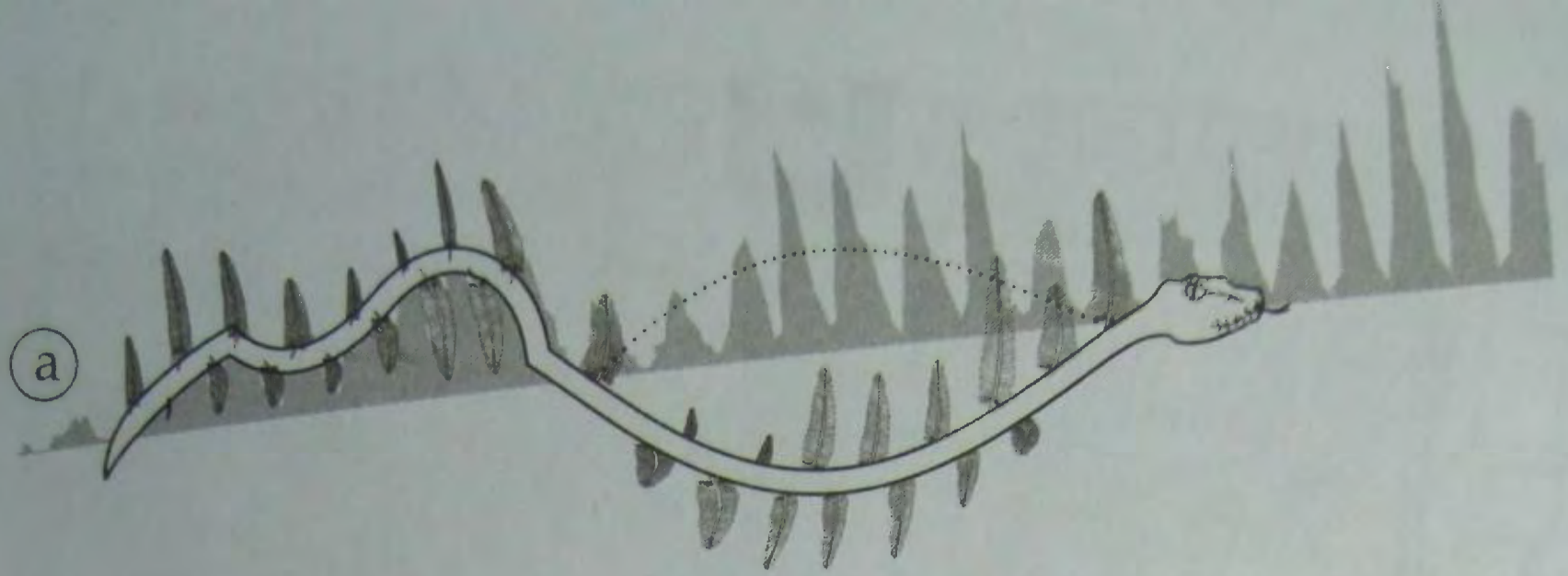

Figure A21. (a) Sketches of the 25,000-year-old lost Tibetan Naacal tablets, made by the explorer James Churchward during his stay in a Tibetan monastery in the 1930s. They show the sinking of the legendary island of Lemuria caused by adverse solar radiation patterns; increased levels of radiation led to the overheating of the landmass, causing the release of subterranean gases and the sinking of the land itself. One of the sketches (labelled as 1^B) shows the Sun as the 'feathered snake'.



(a)



(b)



(c)

Figure A22. (a) Schematic of the the neutral sheet of the Sun illustrated as a feathered snake. The feathered snake of the Sun was worshipped and depicted in carvings and paintings throughout Egypt (b) and Mexico (c).

Tutankhamun, the Feathered Snake of Egypt



Figure A23. Tutankhamun carried the vulture (feathers) and a snake on his forehead. His beard was fashioned as the body of a snake which ended with the tail feathers of a bird.

APPENDIX THREE

The Sun as the Feathered Snake

The Sun as the Feathered Snake

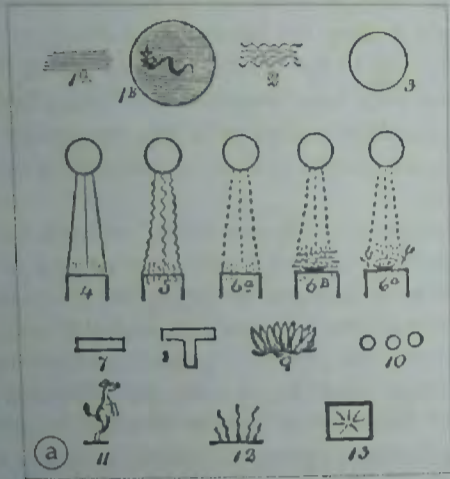

Figure A21. (a) Sketches of the 25,000-year-old lost Tibetan Naacal tablets, made by the explorer James Churchward during his stay in a Tibetan monastery in the 1930s. They show the sinking of the legendary island of Lemuria caused by adverse solar radiation patterns; increased levels of radiation led to the overheating of the landmass, causing the release of subterranean gases and the sinking of the land itself. One of the sketches (labelled as 1B) shows a feathered snake-like mark across the face of the Sun—the earliest known depiction showing the Sun as the 'feathered snake'.

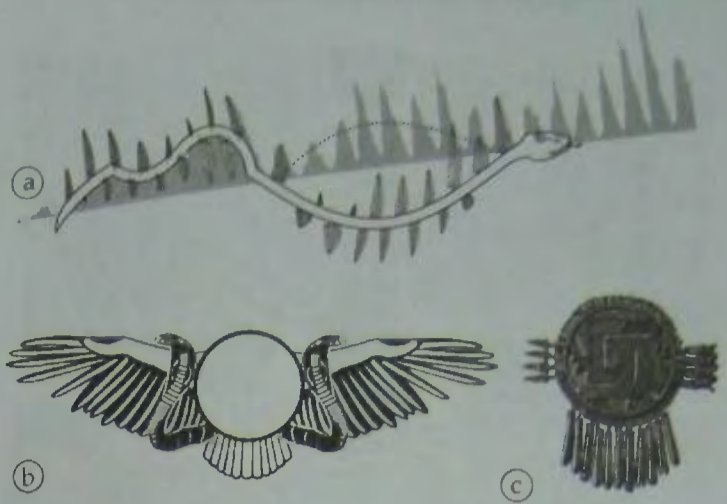

Figure A22. (a) Schematic of the the neutral sheet of the Sun illustrated as a feathered snake. The feathered snake of the Sun was worshipped and depicted in carvings and paintings throughout Egypt (b) and Mexico (c).

Tutankhamun, the Feathered Snake of Egypt



Figure A23. Tutankhamun carried the vulture (feathers) and a snake on his forehead. His beard was fashioned as the body of a snake which ended with the tail feathers of a bird.

The Sun as the Feathered Snake

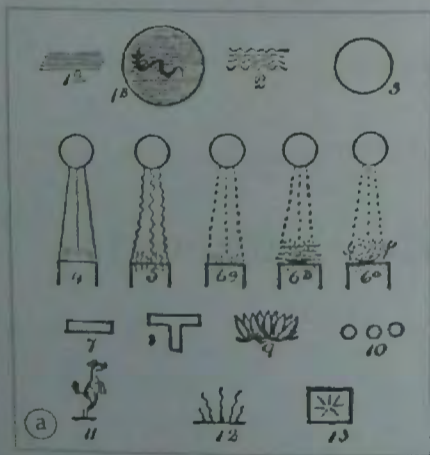

Figure A21. (a) Sketches of the 25,000-year-old lost Tibetan Naacal tablets, made by the 1930s explorer James Churchward during his stay in a Tibetan monastery in the 1930s. They show the sinking of the legendary Island of Lemuria caused by adverse solar radiation patterns; increased levels of radiation led to the overheating of the land mass causing the release of subterranean gases and the sinking of the land itself. One of the sketches (labelled as 1B) shows a feathered snake-like mark across the face of the Sun—the earliest known depiction showing the Sun as the 'feathered snake'.

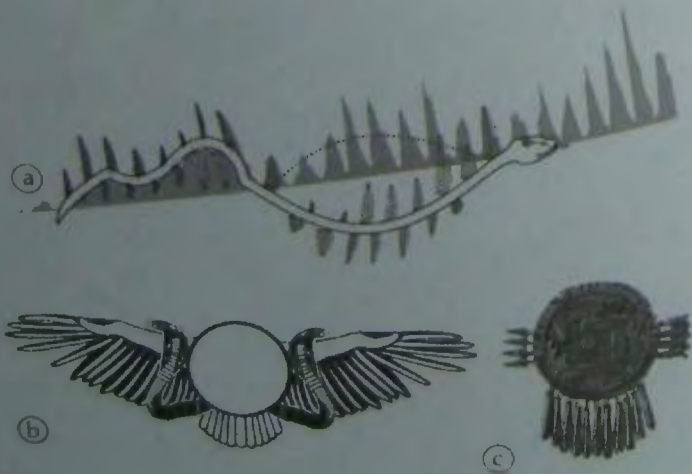

Figure A22. (a) Schematic of the the neutral sheet of the Sun illustrated as a feathered snake. The feathered snake of the Sun was worshipped and depicted in carvings and paintings throughout Egypt (b) and Mexico (c).

Tutankhamun, the Feathered Snake of Egypt



Figure A23. Tutankhamun carried the vulture (feathers) and a snake on his forehead. His beard was fashioned as the body of a snake which ended with the tail feathers of a bird.

Viracocha, the Feathered Snake of Peru

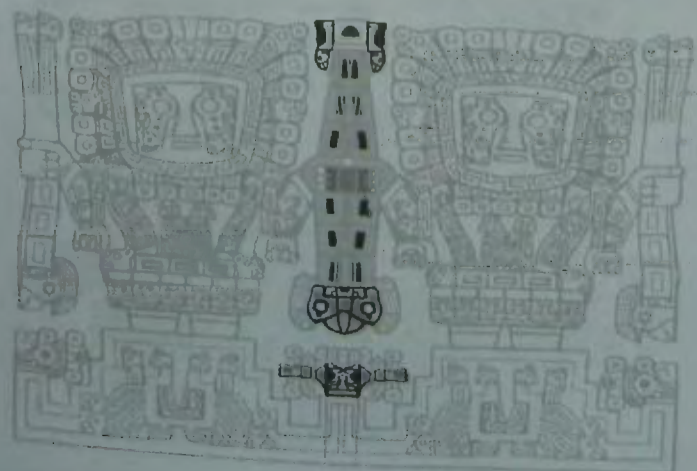

Figure A24. The Viracocha Transformer from the Gateway of the Sun, Tiahuanaco, showing Viracocha as the feathered snake.

Viracocha, the Feathered Snake of Peru

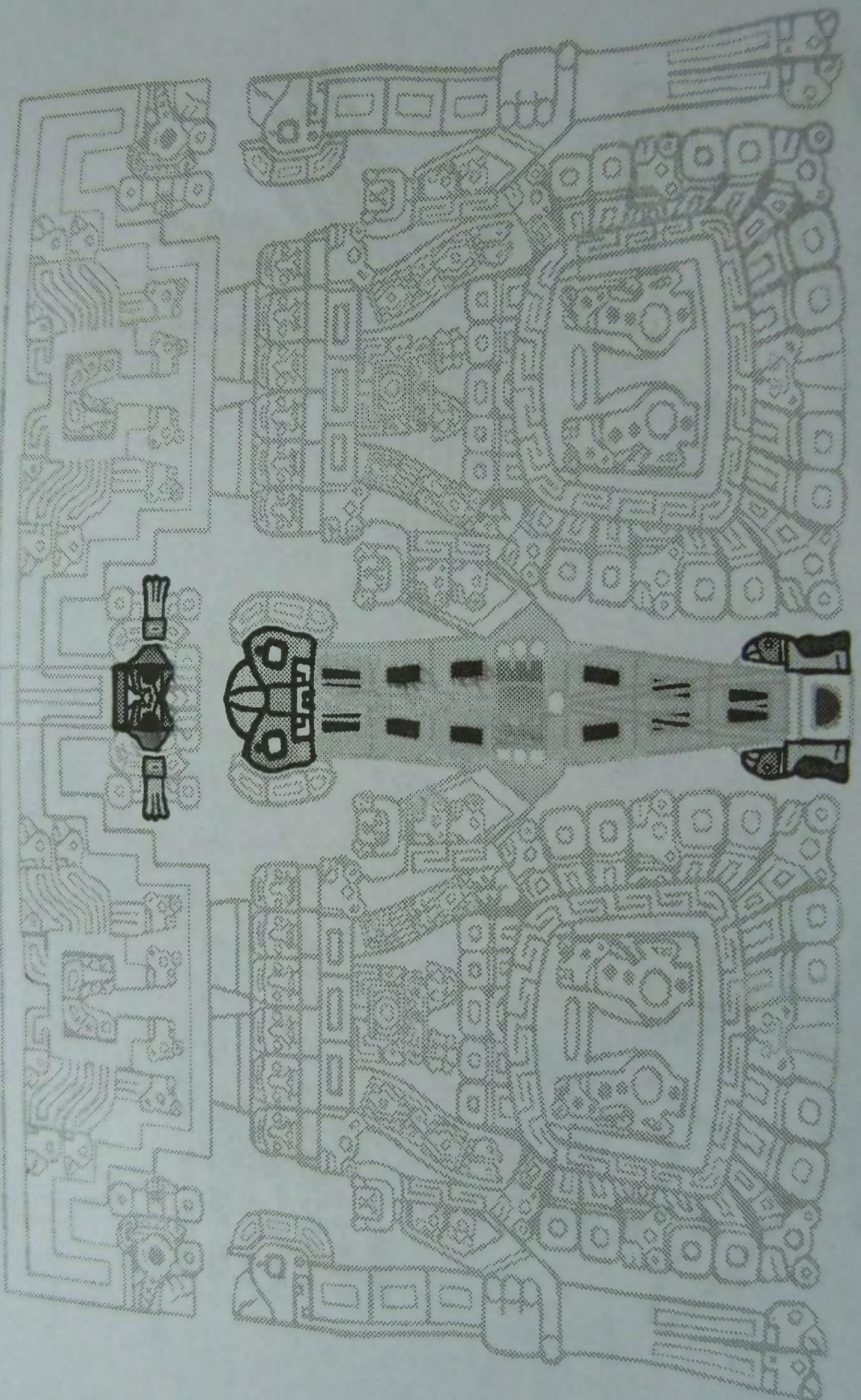
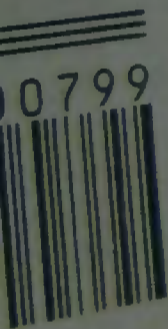

Figure A24. The Viracocha Transformer from the Gateway of the Sun, Tiahuanaco, showing Viracocha as the feathered snake.



The Feathered Snake Drawings of Nazca

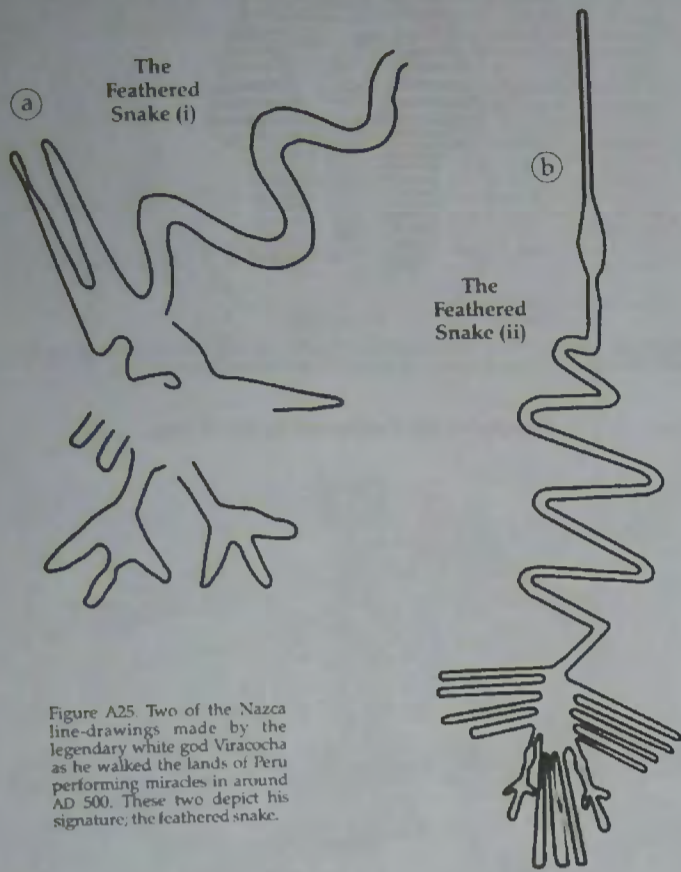

Figure A25. Two of the Nazca line-drawings made by the legendary white god Viracocha as he walked the lands of Peru performing miracles in around AD 500. These two depict his signature; the feathered snake.

Not to scale. Orientation and position shown for illustration purposes only.

The Feathered Snake of Viracocha

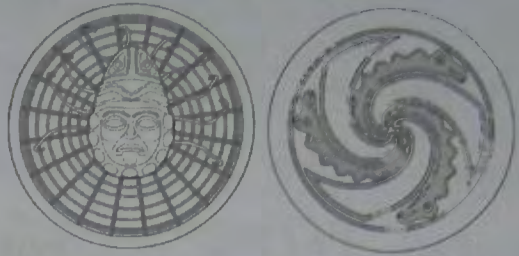

Figure A26. Viracocha as the feathered snake, featured on the golden spider-chambers from his tomb at Sipan c. AD 500.

Lord Pacal, the Feathered Snake of Mexico

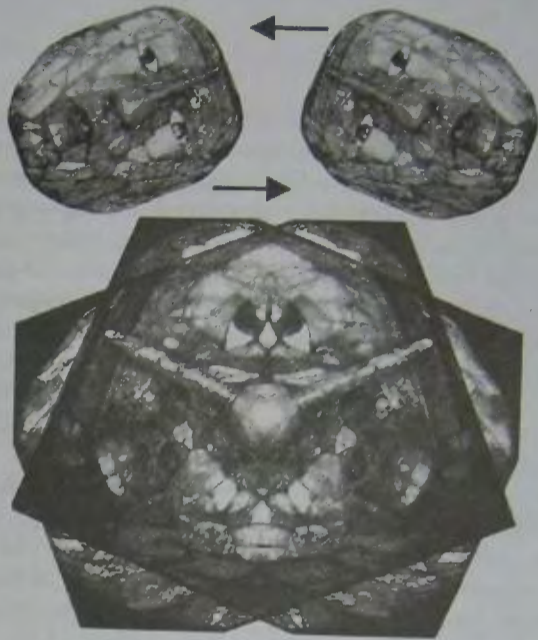

Figure A27. Lord Pacal as the feathered snake, from the decoded mosaic jade mask found in his tomb at Palenque c. AD 750. The picture is revealed only when the transparencies are each rotated by 66.6° (the number from Revelation [666]) and overlaid as shown.

Viracocha, the Feathered Snake of Peru

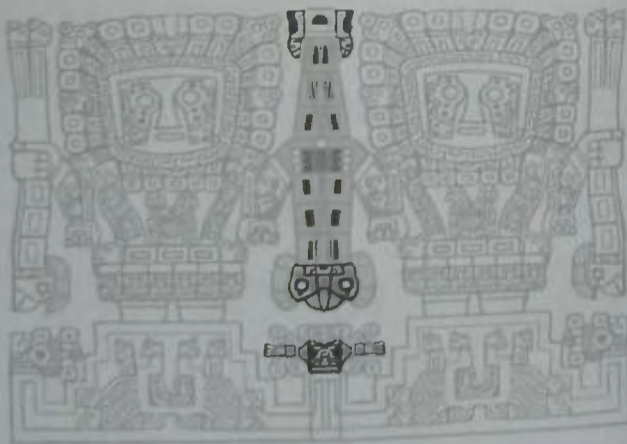

Figure A24. The Viracocha transformer from the Gateway of the Sun, Tiahuanaco, showing Viracocha as the feathered snake.

The Feathered Snake of Viracocha

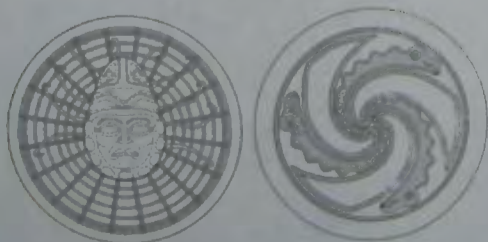
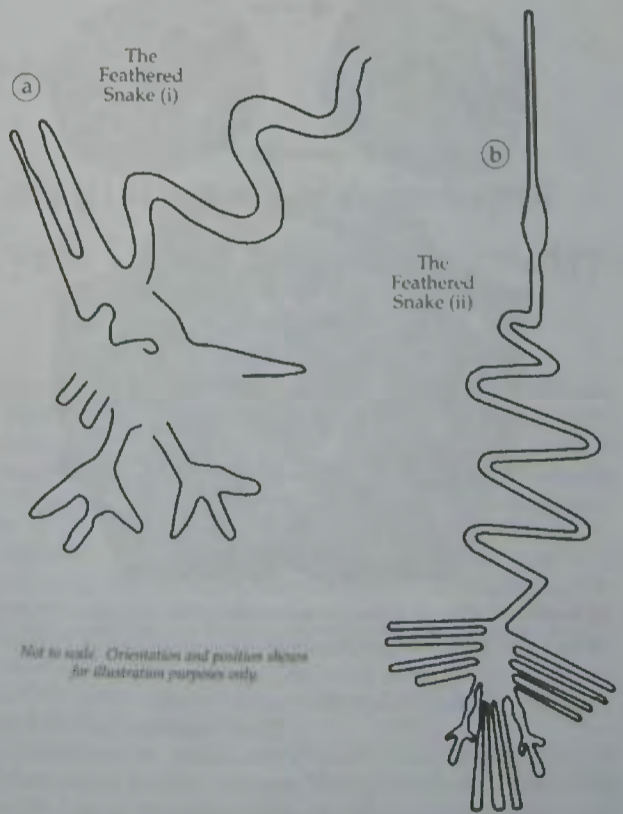

Figure A25. Viracocha as the feathered snake, featured on the golden spider chambers from his tomb at Sipan c. AD 500.

The Feathered Snake Drawings of Nazca



Not to scale. Orientation and position shown for illustration purposes only.

Figure A26. Two of the Nazca line drawings made by the legendary white god Viracocha as he walked the lands of Peru performing miracles in around AD 500. These two depict his signature; the feathered snake.

The Feathered Snake of Viracocha

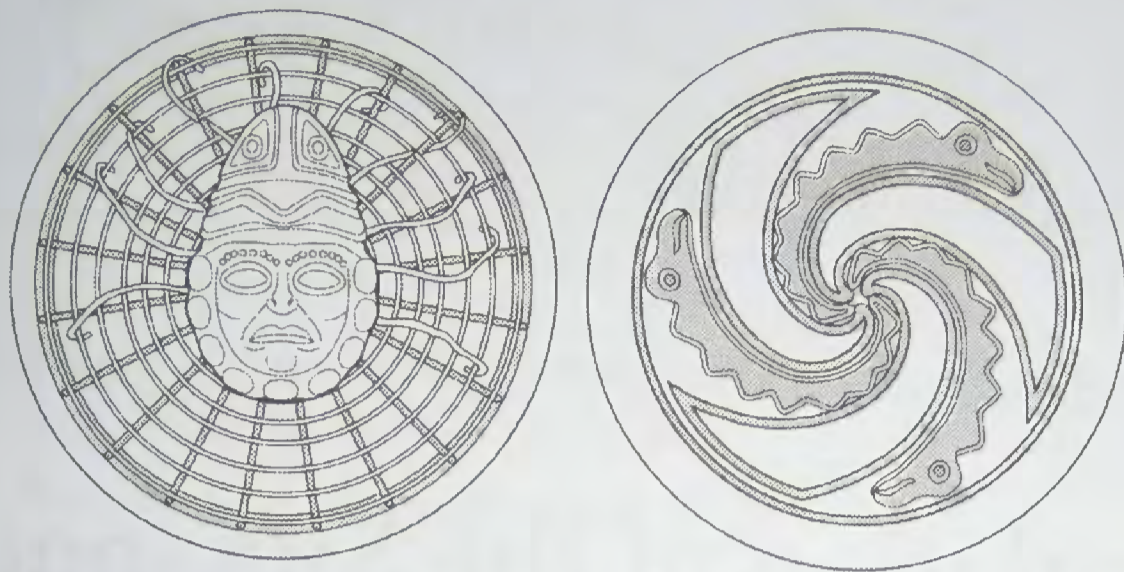

Figure A26. Viracocha as the feathered snake, featured on the golden spider-chambers from his tomb at Sipan c. AD 500.

Lord Pacal, the Feathered Snake of Mexico

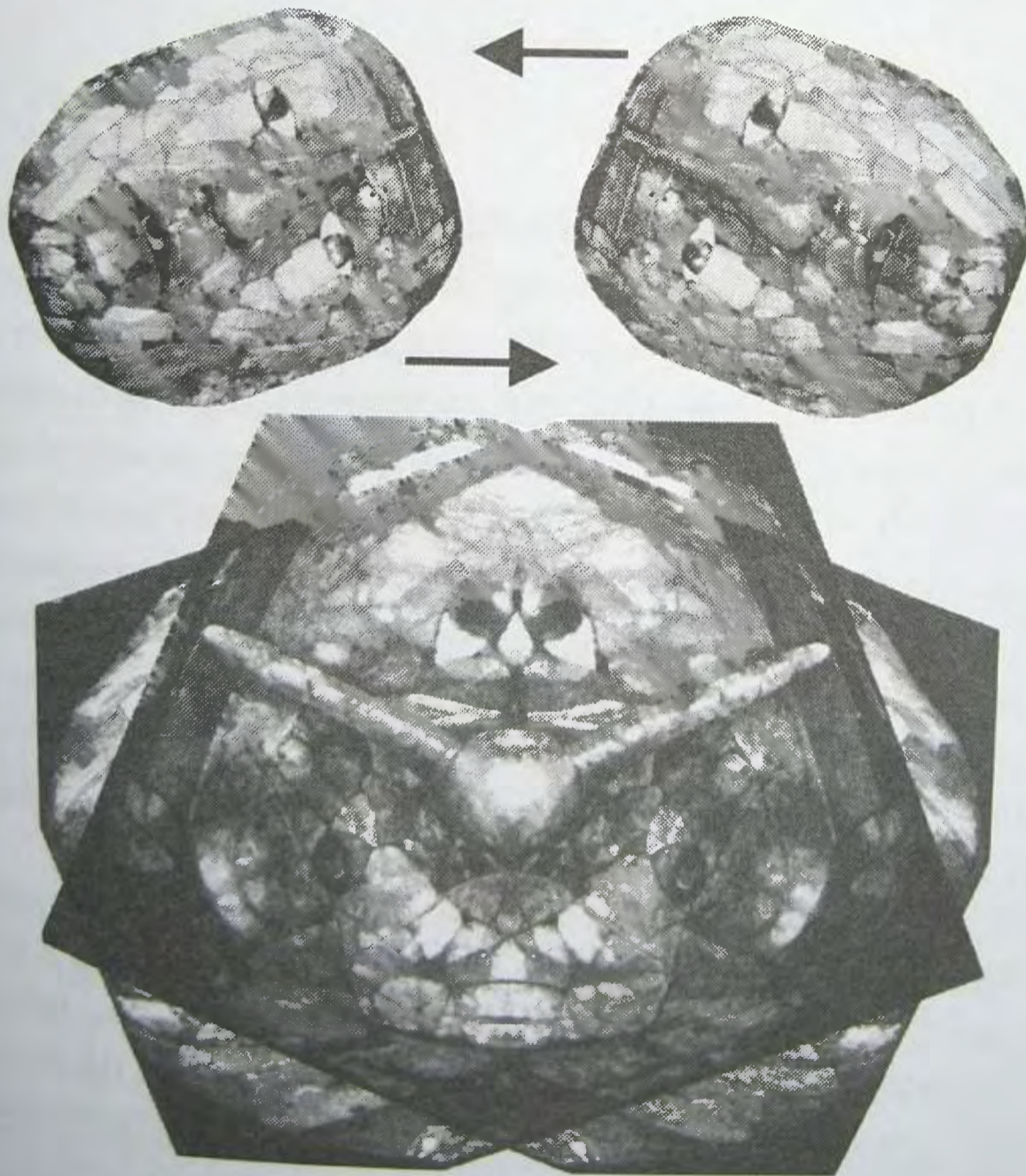

Figure A27. Lord Pacal as the feathered snake, from the decoded mosaic jade mask found in his tomb at Palenque c. AD 750. The picture is revealed only when the transparencies are each rotated by 66.6° (the number from Revelation [666]) and overlaid as shown.

Viracocha, the Feathered Snake of Peru

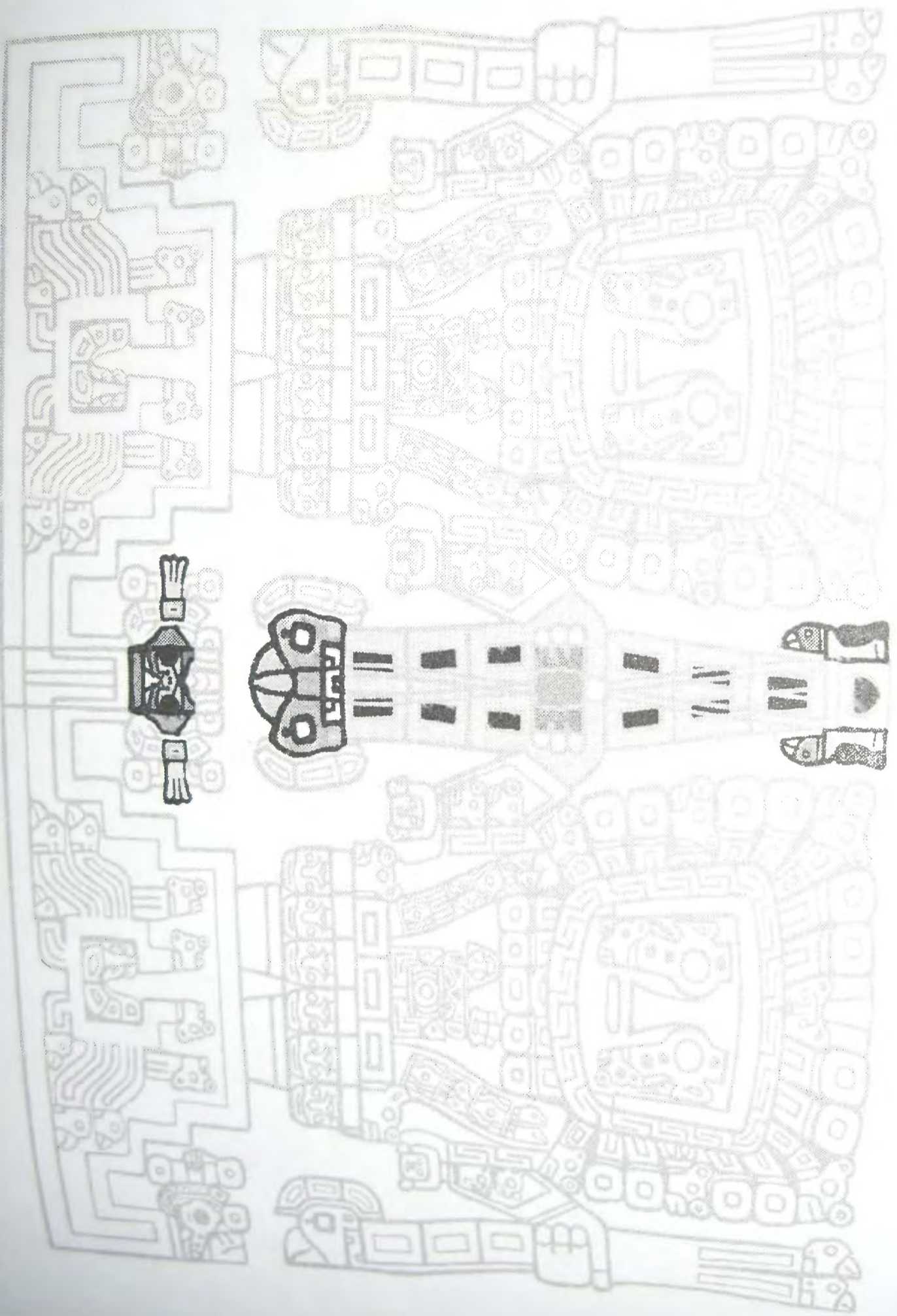

Figure A24. The Viracocha transformer from the Gateway of the Sun, Tiahuanaco, showing Viracocha as the feathered snake.

The Feathered Snake of Viracocha

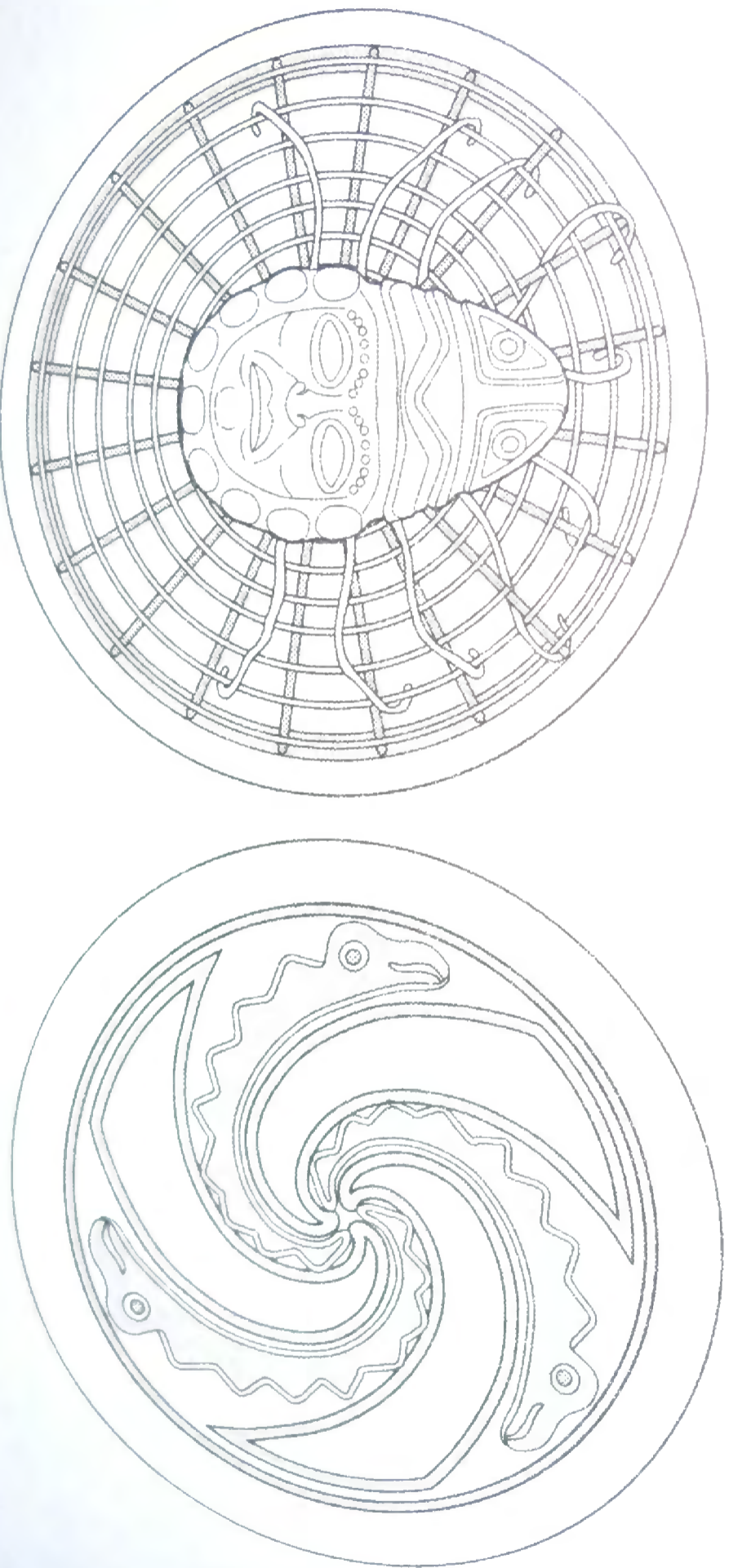

Figure A25. Viracocha as the feathered snake, featured on the golden spider chambers from his tomb at Sipan c. AD 500.



Figure A24. The Viracocha transformer from the Gateway of the Sun, Tiahuanaco, showing Viracocha as the feathered snake.

The Feathered Snake of Viracocha

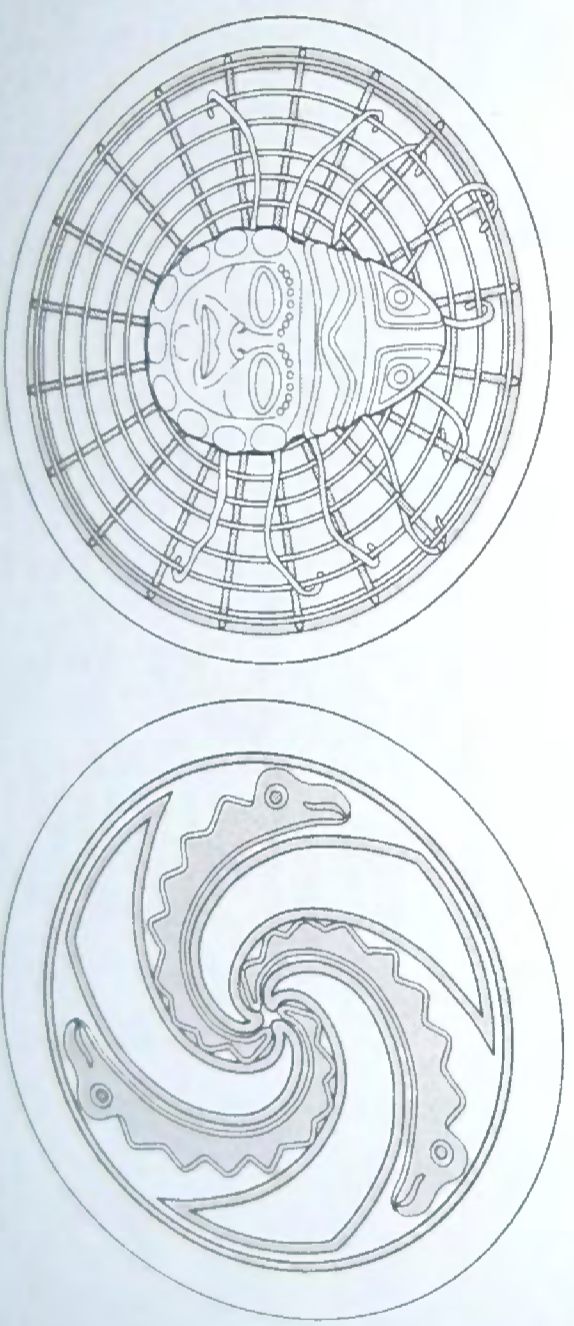

Figure A25. Viracocha as the feathered snake, featured on the golden spider chambers from his tomb at Sipan c. AD 500.

Figure A2
he walked
signature: t

The Feathered Snake of Viracocha

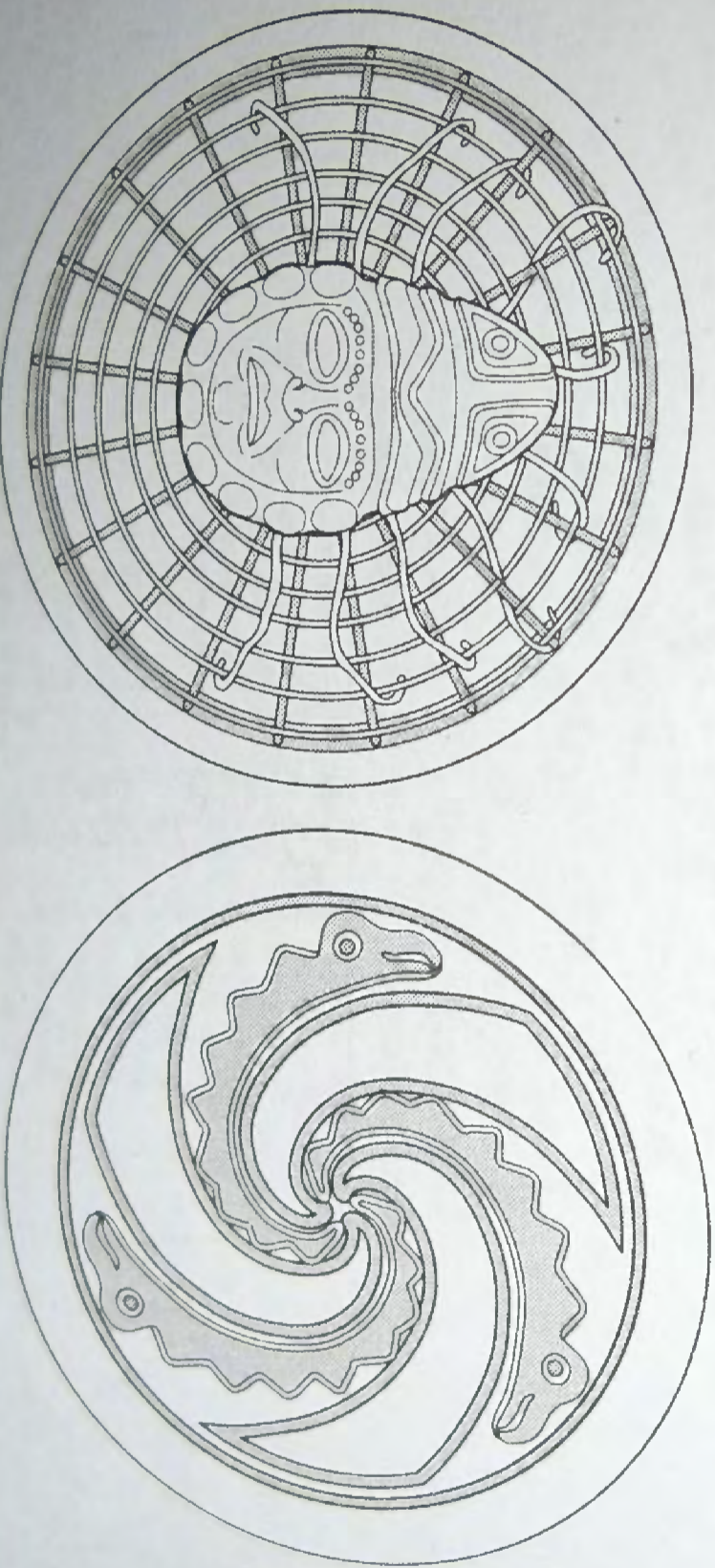

Figure A25. Viracocha as the feathered snake, featured on the golden spider chambers from his tomb at Sipan c. AD 500.

Calculation of the Sunspot Cycle using Sacred Geometry

The 'sacred shapes' encoded into Gothic architecture by the Freemasons, the solar cross, the pentagon, hexagon and octagon, may together be used to calculate the duration of the sunspot cycle without the use of a computer. In revering these shapes they were attempting to convey the hidden-super science of the Sun which affects every aspect of our lives.

Figure A11 shows the computer calculated version of the 187-year sunspot cycle. Figure A28a shows how 6 microcycles of solar magnetic activity amount to one 11.5-year hypothesised cycle (6×8 bits [time intervals of 87.4545 days] = 700 days [48 bits]). This relationship can be simply represented by a 6-sided hexagon (figure A28b) whose sides are each of 8 bits (700 days) in duration (or, as in the case with the Holy Grail, an octagon with sides 6 bits in length).

The hexagon, or octagon, can be placed on top of the microcycle series and rolled over one side every 700 days, or two sides every 1,400 days etc. (figure A29). One complete revolution of the hexagon would amount to 6 microcycles, 48 bits: one 11.49-year hypothesised cycle. All that would be needed is some sort of calendar to keep track of the accumulation of the periods of 700, 1,400 etc. days.

This is all very well until the hexagon encounters the first magnetic microcycle containing a shift bit—which occurs when the 11.49-year cy-

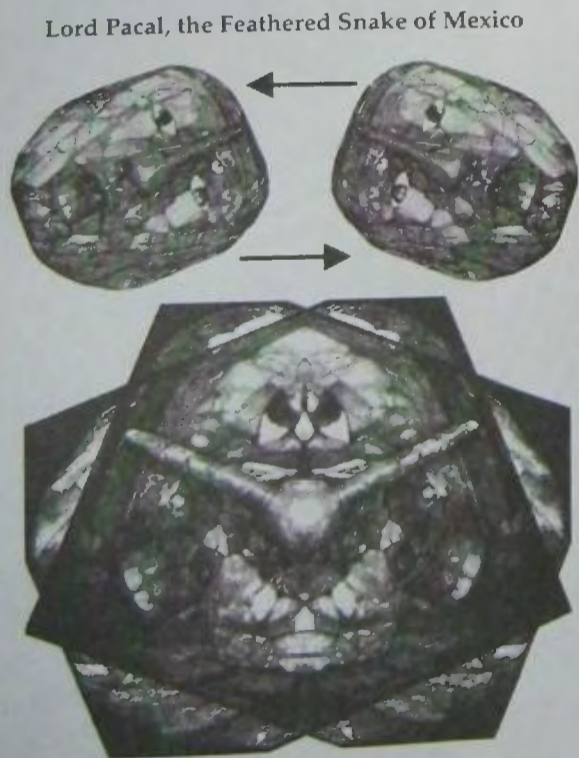
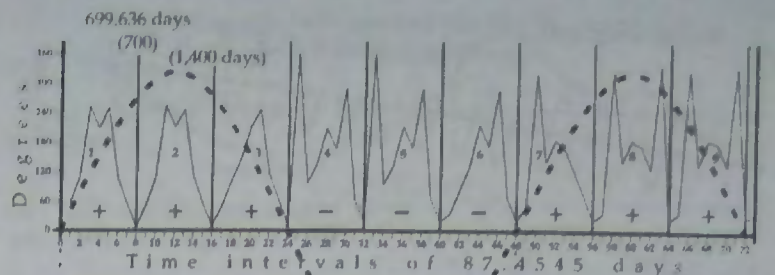
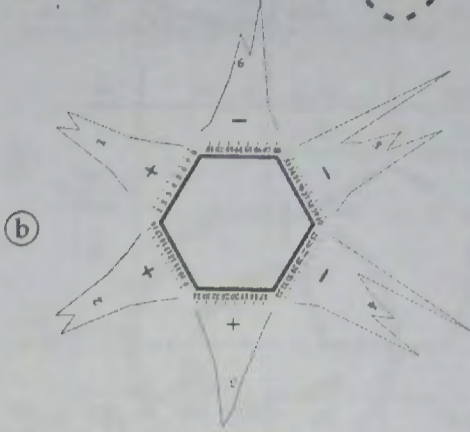

Figure A27. Lord Pacal as the feathered snake, from the decoded mosaic jade mask found in his tomb at Palenque c. AD 750. The picture is revealed only when the transparencies are each rotated by 66.6° (the number from Revelation [666]) and overlaid as shown.



(a) $(48(6 \times 8) \text{ intervals} \times 87.4545 = 4197.818 \text{ days})$ —or (8×6)



Calculation of the Sunspot Cycle using Sacred Geometry

Figure A28. (a) The six microcycles of one hypothesised 11.5-year cycle may be wrapped around a hexagon (b). Each side of the hexagon represents 8 bits of time (8×87.4545 days) 700 days. The hexagon may be used to measure the progress of the cycle providing it is rolled over by one face of the hexagon every 700 days. One complete roll of the hexagon indicates the elapse of one hypothesised cycle. The sunspot cycle may be tracked using this method. Alternatively, an octagon shape, with sides measuring 6 bits, could be used to provide the same result.

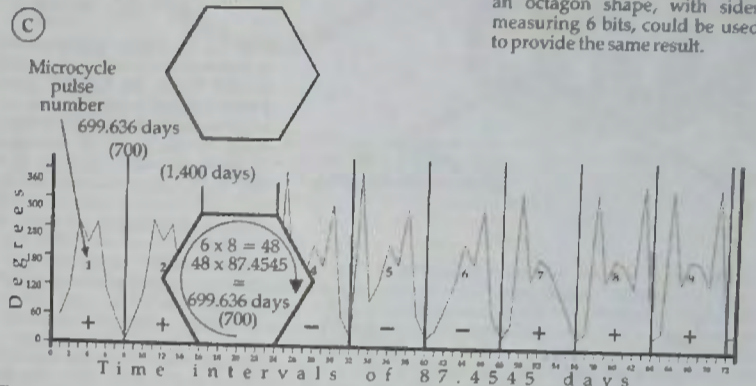

Figure A29. A simple hexagon, rolled over by one side every 700 days, can be used to keep track of sunspot cycles. One complete revolution of the hexagon amounts to one complete sunspot cycle of 11.4929 years.

Calculation of the Sunspot Cycle Using Sacred Geometry

The 'sacred shapes' encoded into Gothic architecture by the Freemasons, the solar cross, the pentagon, hexagon and octagon, may together be used to calculate the duration of the sunspot cycle without the use of a computer. In revering these shapes they were attempting to convey the hidden super-science of the Sun which affects every aspect of our lives.

Figure A11 shows the computer-calculated version of the 187-year sunspot cycle. Figure A28a shows how 6 microcycles of solar magnetic activity amount to one 11.5-year hypothesised cycle (6×8 bits [time intervals of 87.4545 days] = 700 days [48 bits]). This relationship can be simply represented by a hexagon (figure A28b) whose sides are each of 8 bits (700 days) in duration (or, as in the case with the Holy Grail, an octagon with sides 6 bits in length).

The hexagon, or octagon, can be placed on top of the microcycle series and rolled over one side every 700 days, or two sides every 1,400 days, etc. (figure A29). One complete revolution of the hexagon would amount to 6 microcycles, 48 bits: one 11.49-year hypothesised cycle. All that would be needed is some sort of calendar to keep track of the accumulation of the periods of 700, 1,400, etc., days.

This is all very well until the hexagon encounters the first magnetic microcycle containing a shift bit—which occurs when the 11.49-year cycle and the 187-year cycle cross over and interfere with each

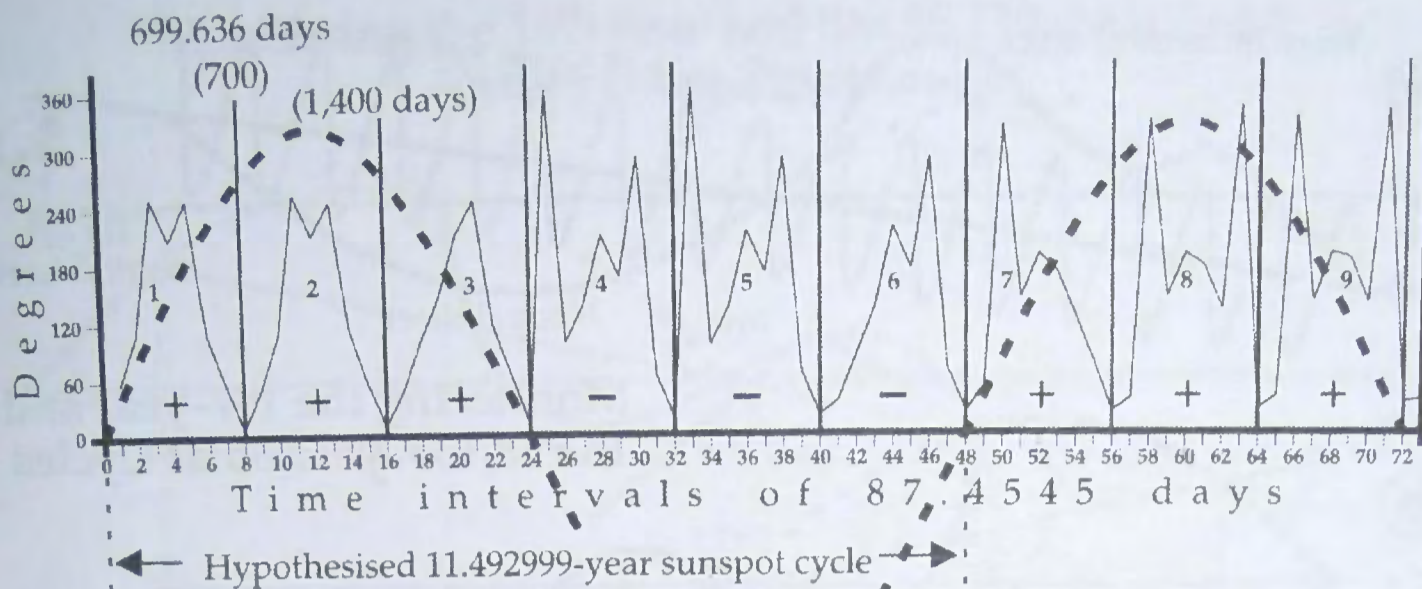

(a) $(48 \times 8) \text{ intervals} \times 87.4545 = 4197.818 \text{ days}$ — or (8×6)

Calculation of the Sunspot Cycle using Sacred Geometry

Figure A28. (a) The six microcycles of one hypothesised 11.5-year cycle may be wrapped around a hexagon (b). Each side of the hexagon represents 8 bits of time (8×87.4545 days) 700 days. The hexagon may be used to measure the progress of the cycle providing it is rolled over by one face of the hexagon every 700 days. One complete roll of the hexagon indicates the elapse of one hypothesised cycle. The sunspot cycle may be tracked using this method. Alternatively, an octagon shape, with sides measuring 6 bits, could be used to provide the same result.

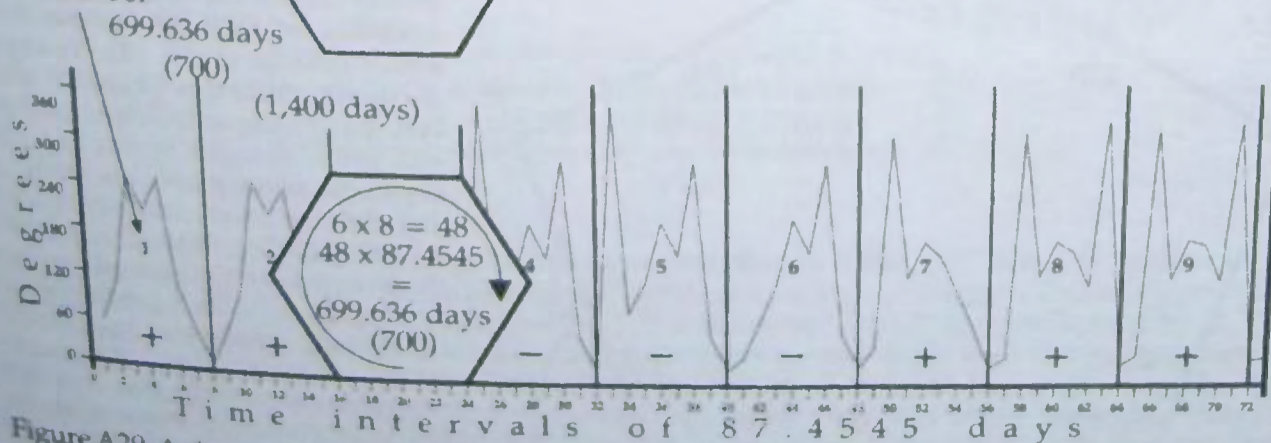
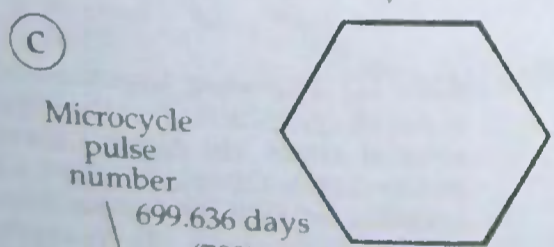
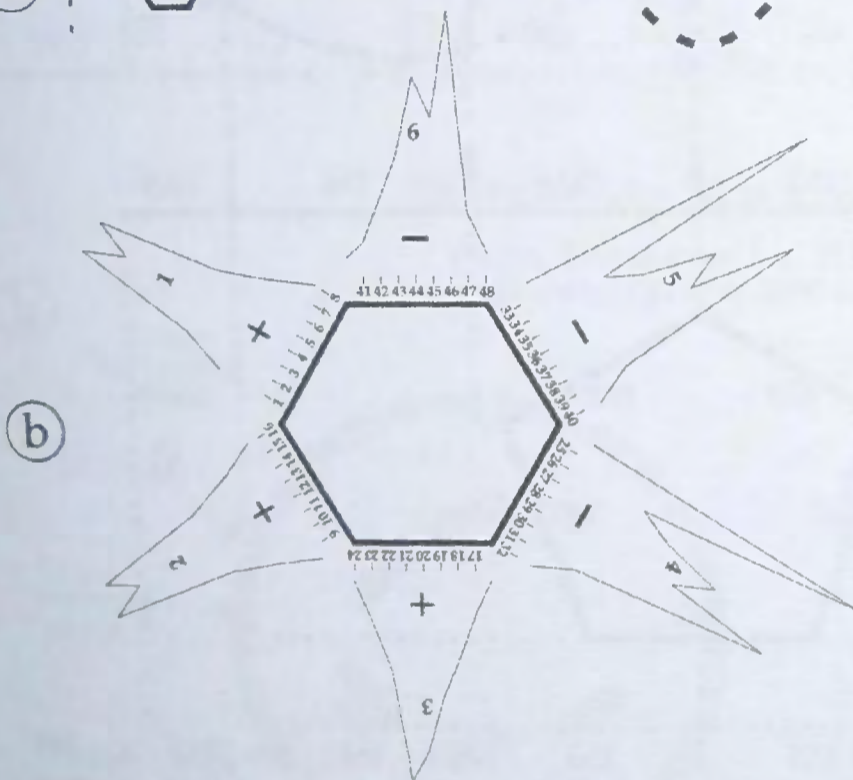

Figure A29. A simple hexagon, rolled over by one side every 700 days, can be used to keep track of sunspot cycles. One complete revolution of the hexagon amounts to one complete sunspot cycle of 11.4929 years.

Lord Pacal, the Feathered Snake of Mexico

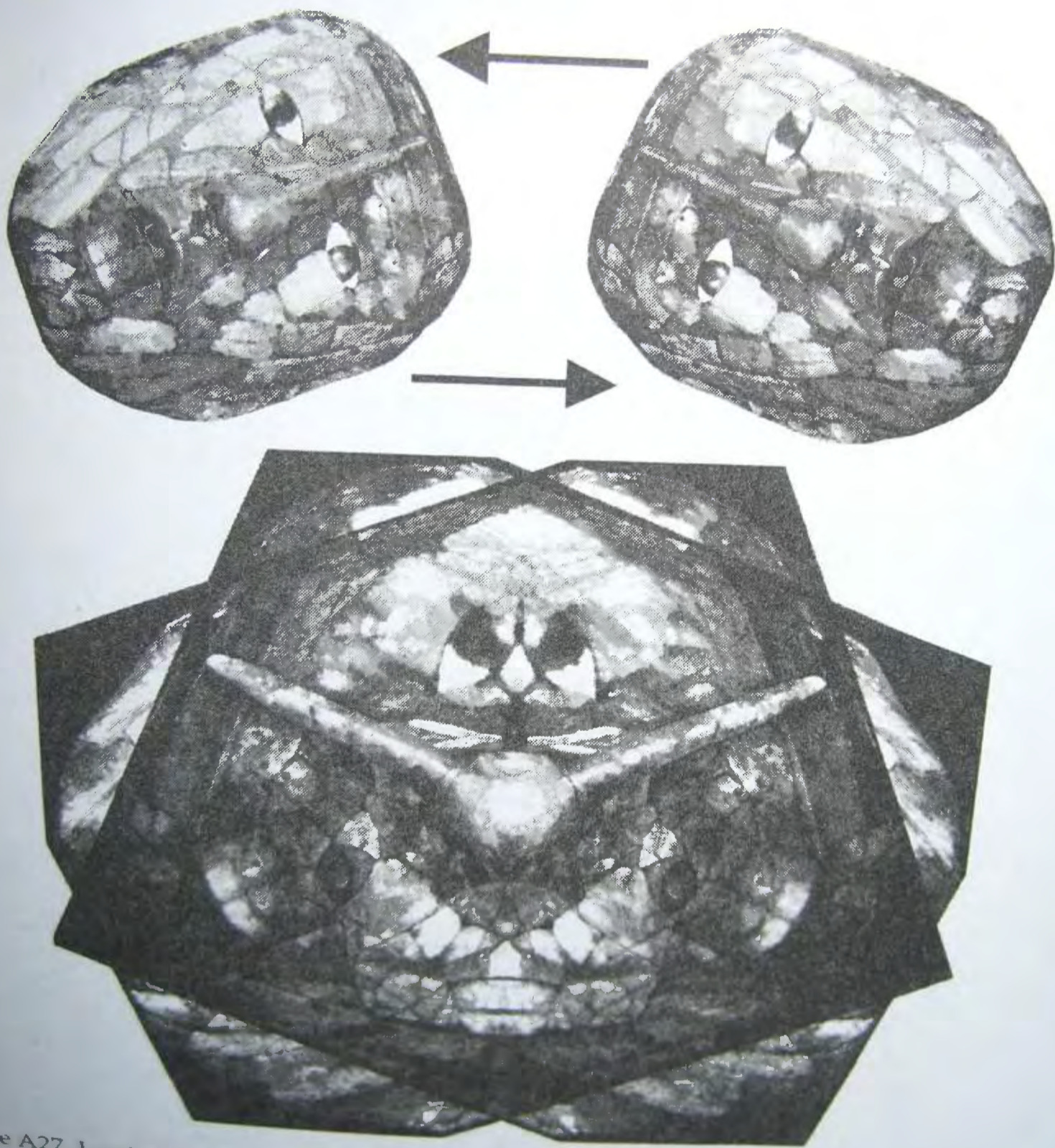
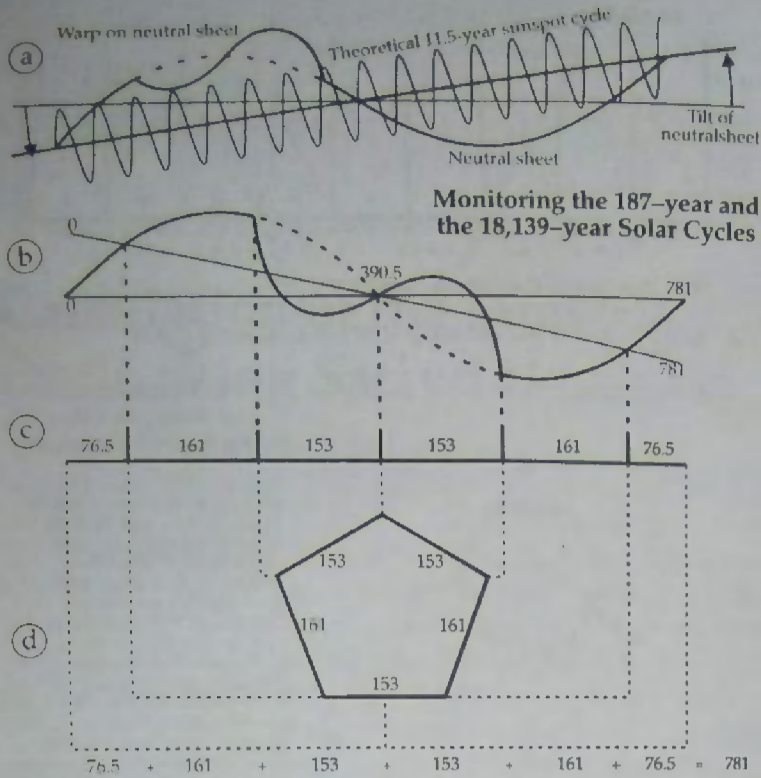

Figure A27. Lord Pacal as the feathered snake, from the decoded mosaic jade mask found in his tomb at Palenque c. AD 750. The picture is revealed only when the transparencies are each rotated by 66.6° (the number from Revelation [666]) and overlaid as shown.



Monitoring the 187-year and the 18,139-year Solar Cycles

A30. (a) 11.5-year hypothesised sunspot cycle carried on the tilted neutral sheet. (b) Neutral sheet (rotated to facilitate projection). (c) Location of shift bit intersections along neutral sheet. (d) Pentagon showing distances between shift bits. The hexagon rollover method will track sunspot cycles but will begin to accumulate an error of one shift bit on encountering shift bit microcycles. To overcome this the hexagon can be placed inside a pentagon. (e) The pentagon is rolled over whenever insufficient space remains for one more hexagon rollover. In this way the 187-year sunspot cycle can be monitored accurately over the 18,139-year grand solar cycle.

Monitoring the 187-year and the 18,139-year Solar Cycles using Stonehenge

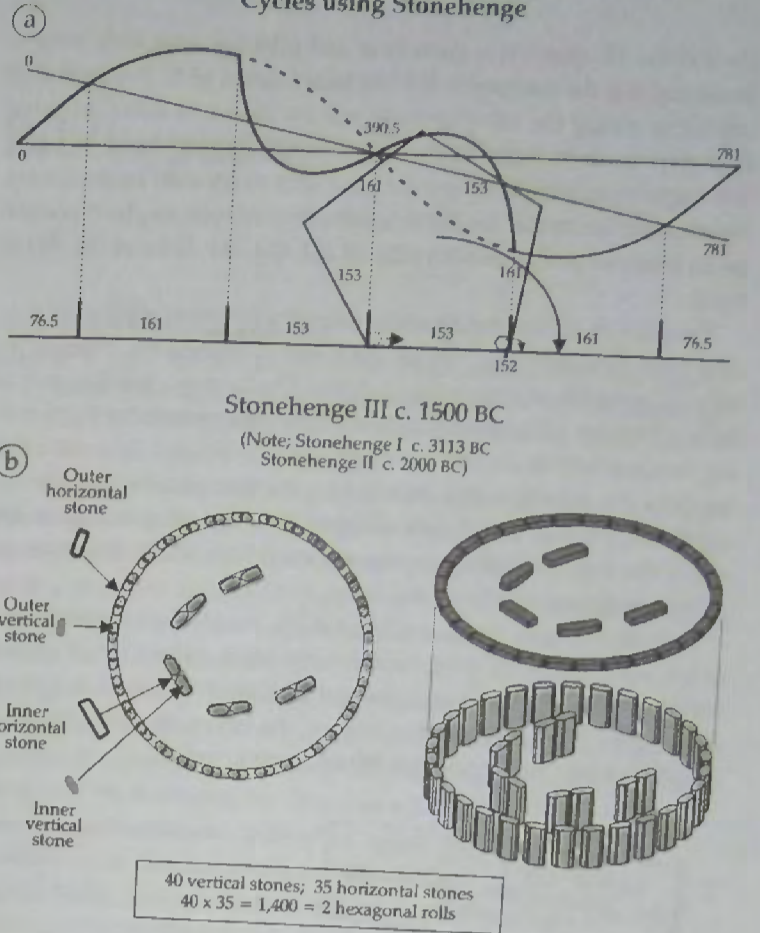

Stonehenge III c. 1500 BC

(Note: Stonehenge I c. 3113 BC
Stonehenge II c. 2000 BC)

Figure A31. (a) The hexa-pentagon arrangement shows how the sunspot cycle can be monitored using hexagons (or octagons) in conjunction with a pentagon. These shapes were encoded by the Gothic Masons in their cathedral architecture during the medieval period. This formed the basis for Sacred Geometry, the geometric shapes built into the architecture of churches throughout Europe. (b) Stonehenge can be used to track the sunspot cycle: the trilithon arrangements (3-stone arches on both the outer ring and inner horseshoe ring) at Stonehenge are made up of 40 vertical stones and 35 horizontal stones (in total). If one stone is marked each day, then all stones would be marked after 1,400 days (40 x 35). The marking of stones could be used as a calendrical accumulator in conjunction with the hexa-pentagon method of sunspot calculation.

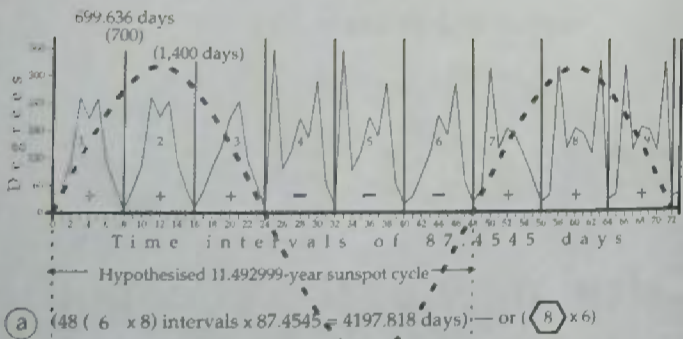

Calculation of the Sunspot Cycle Using Sacred Geometry

Figure A28 (a) The six microcycles of one hypothesised 11.5-year cycle may be wrapped around a hexagon (b). Each side of the hexagon represents 8 bits of time (8 x 87,454.5 days = 700 days). The hexagon may be used to measure the progress of the cycle providing it is rolled over by one face of the hexagon every 700 days. One complete roll of the hexagon indicates the elapse of one hypothesised cycle. The sunspot cycle may be tracked using this method. Alternatively, an octagon shape, with sides measuring 6 bits, could be used to provide the same result.

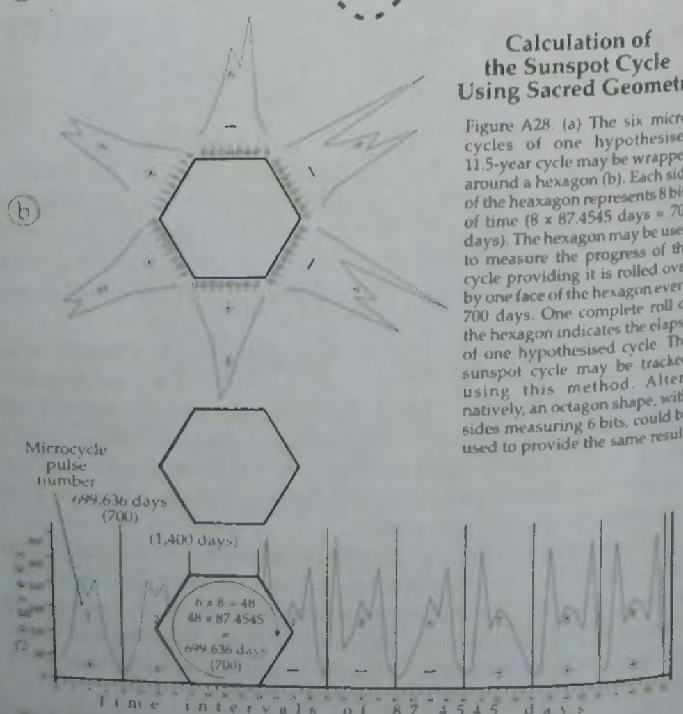
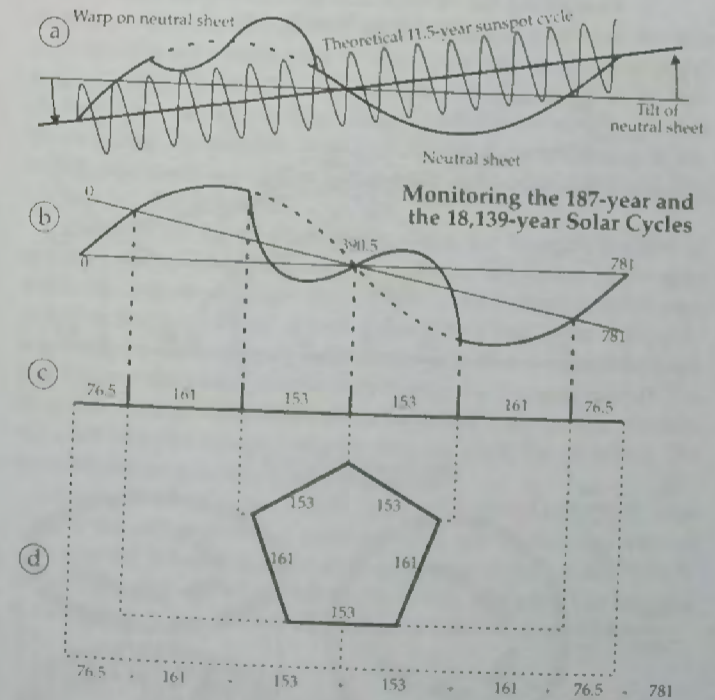
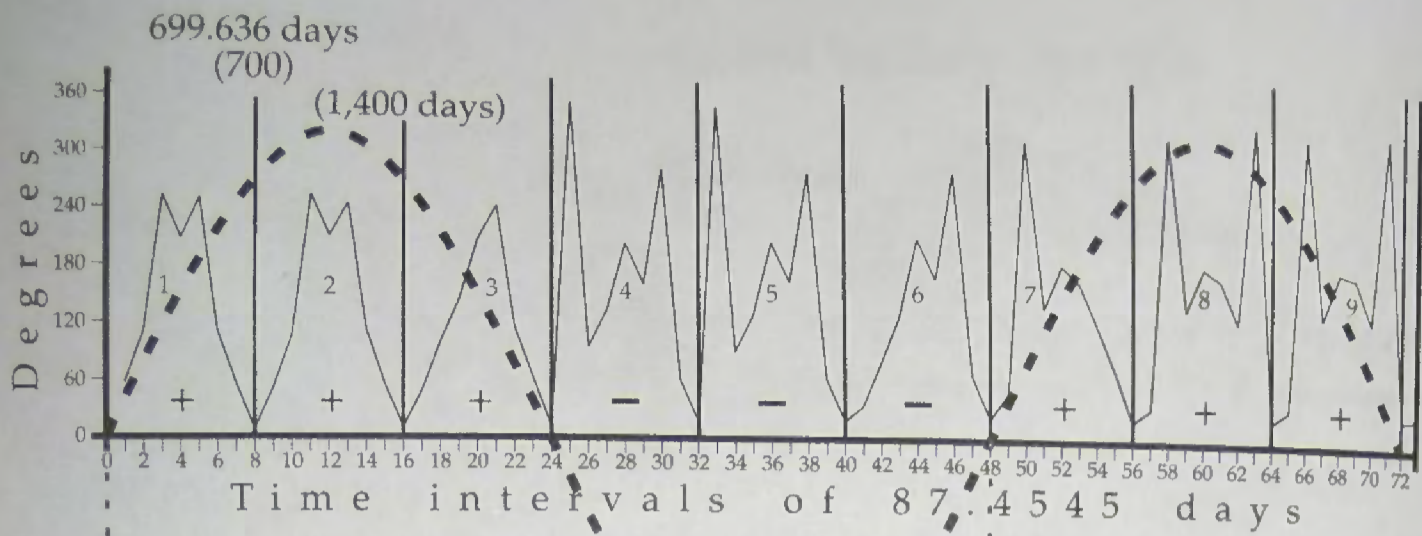

Figure A29. A simple hexagon, rolled over by one side every 700 days, can be used to keep track of sunspot cycles. One complete revolution of the hexagon amounts to one complete sunspot cycle of 11.4929 years.



Monitoring the 187-year and the 18,139-year Solar Cycles

A30. (a) 11.5-year hypothesised sunspot cycle carried on the tilted neutral sheet. (b) Neutral sheet (rotated to facilitate projection). (c) Location of shift bit intersections along neutral sheet. (d) Pentagon showing distances between shift bits. The hexagon rollover method will track sunspot cycles but will begin to accumulate an error of one shift bit on encountering shift bit microcycles. To overcome this the hexagon can be placed inside a pentagon. (e) The pentagon is rolled over whenever insufficient space remains for one more hexagon rollover. In this way the 187-year sunspot cycle can be monitored accurately over the 18,139-year grand solar cycle.



Hypothesised 11.492999-year sunspot cycle

(a) $(48 (6 \times 8) \text{ intervals} \times 87.4545 = 4197.818 \text{ days})$ — or $(\text{Hexagon } 8 \times 6)$

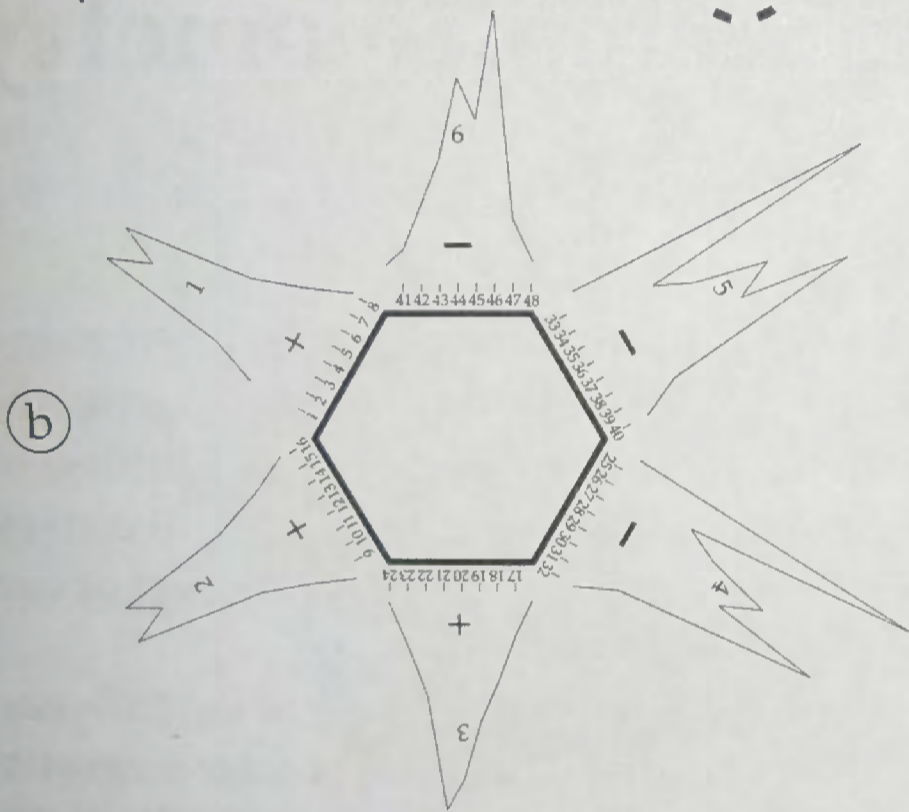

Calculation of the Sunspot Cycle Using Sacred Geometry

Figure A28. (a) The six microcycles of one hypothesised 11.5-year cycle may be wrapped around a hexagon (b). Each side of the hexagon represents 8 bits of time ($8 \times 87.4545 \text{ days} = 700 \text{ days}$). The hexagon may be used to measure the progress of the cycle providing it is rolled over by one face of the hexagon every 700 days. One complete roll of the hexagon indicates the elapse of one hypothesised cycle. The sunspot cycle may be tracked using this method. Alternatively, an octagon shape, with sides measuring 6 bits, could be used to provide the same result.

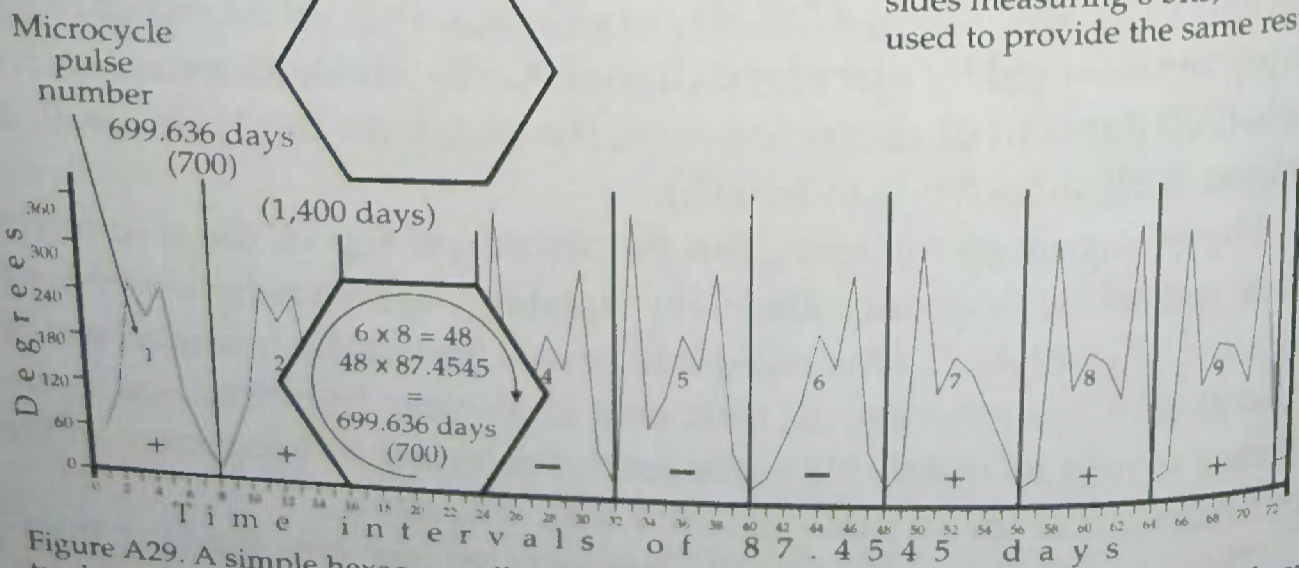
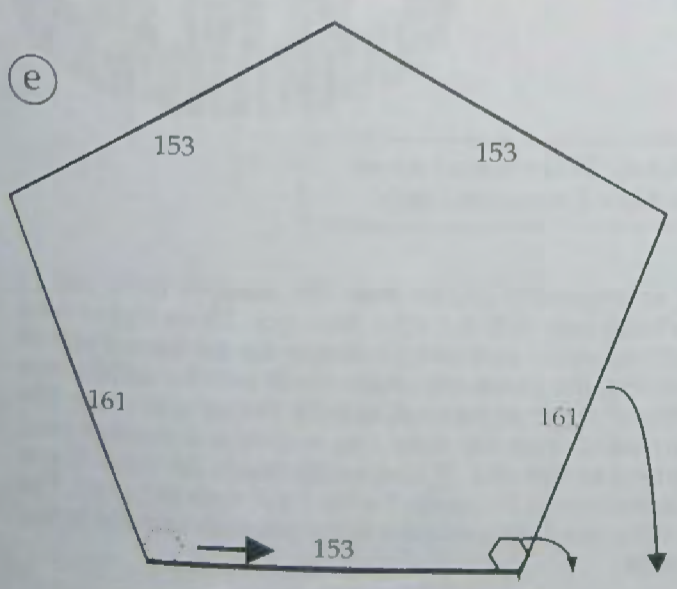
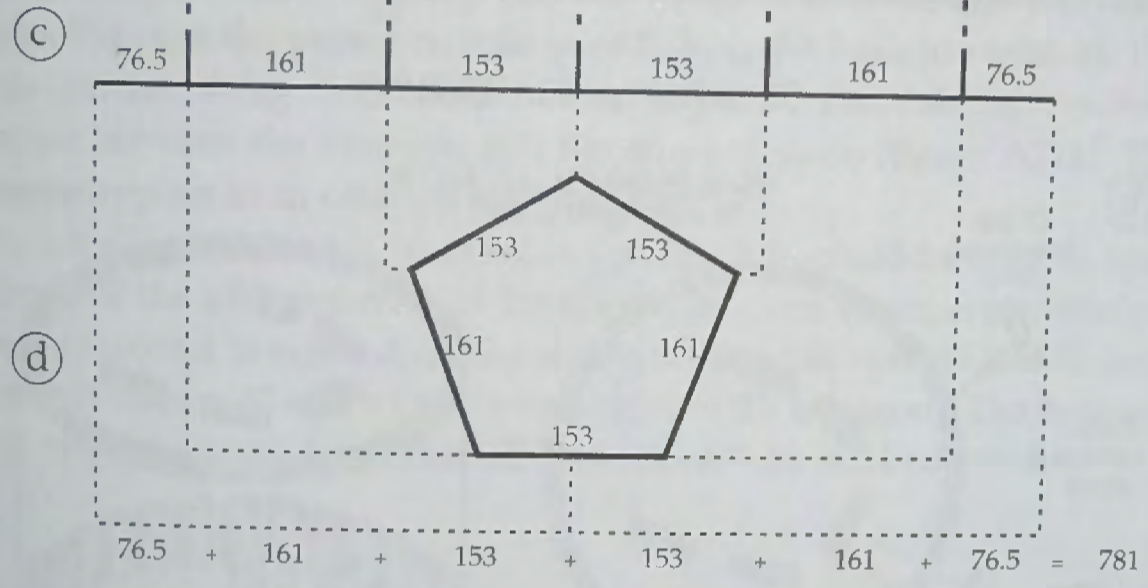
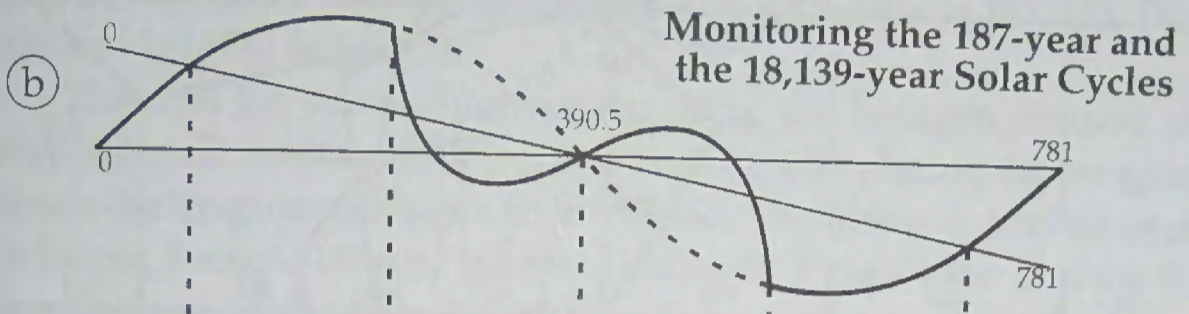
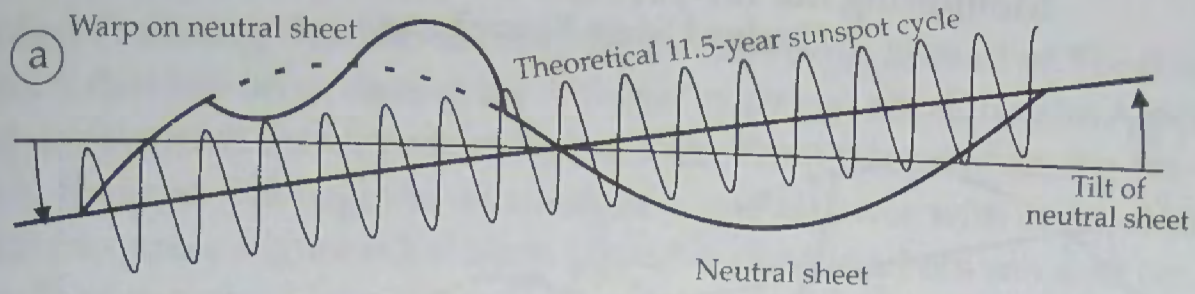

Figure A29. A simple hexagon, rolled over by one side every 700 days, can be used to keep track of sunspot cycles. One complete revolution of the hexagon amounts to one complete sunspot cycle of 11.4929 years.



A30. (a) 11.5-year hypothesised sunspot cycle carried on the tilted neutral sheet. (b) Neutral sheet (rotated to facilitate projection). (c) Location of shift bit intersections along neutral sheet. (d) Pentagon showing distances between shift bits. The hexagon rollover method will track sunspot cycles but will begin to accumulate an error of one shift bit on encountering shift bit microcycles. To overcome this the hexagon can be placed inside a pentagon. (e) The pentagon is rolled over whenever insufficient space remains for one more hexagon rollover. In this way the 187-year sunspot cycle can be monitored accurately over the 18,139-year grand solar cycle.

a of
Cycle
ometry

six micro-
pothesised
be wrapped
). Each side
resents 8 bits
days = 700
may be used
gress of the
s rolled over
exagon every
plete roll of
tes the elapse
ed cycle. The
y be tracked
hod. Alter-
n shape, with
bits, could be
e same result.

be used to keep
to one complete

... treasures of
... tell the same story
... rives today, concealed
... nurch and the higher
... time ever, Maurice
... crecy, reasons which
... all.
... ever read in my life'
... of *The Outsider*

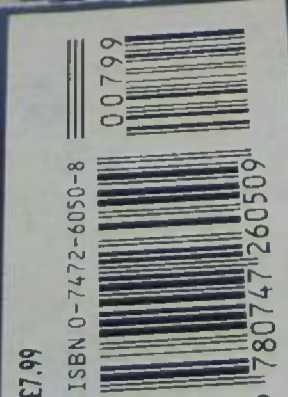

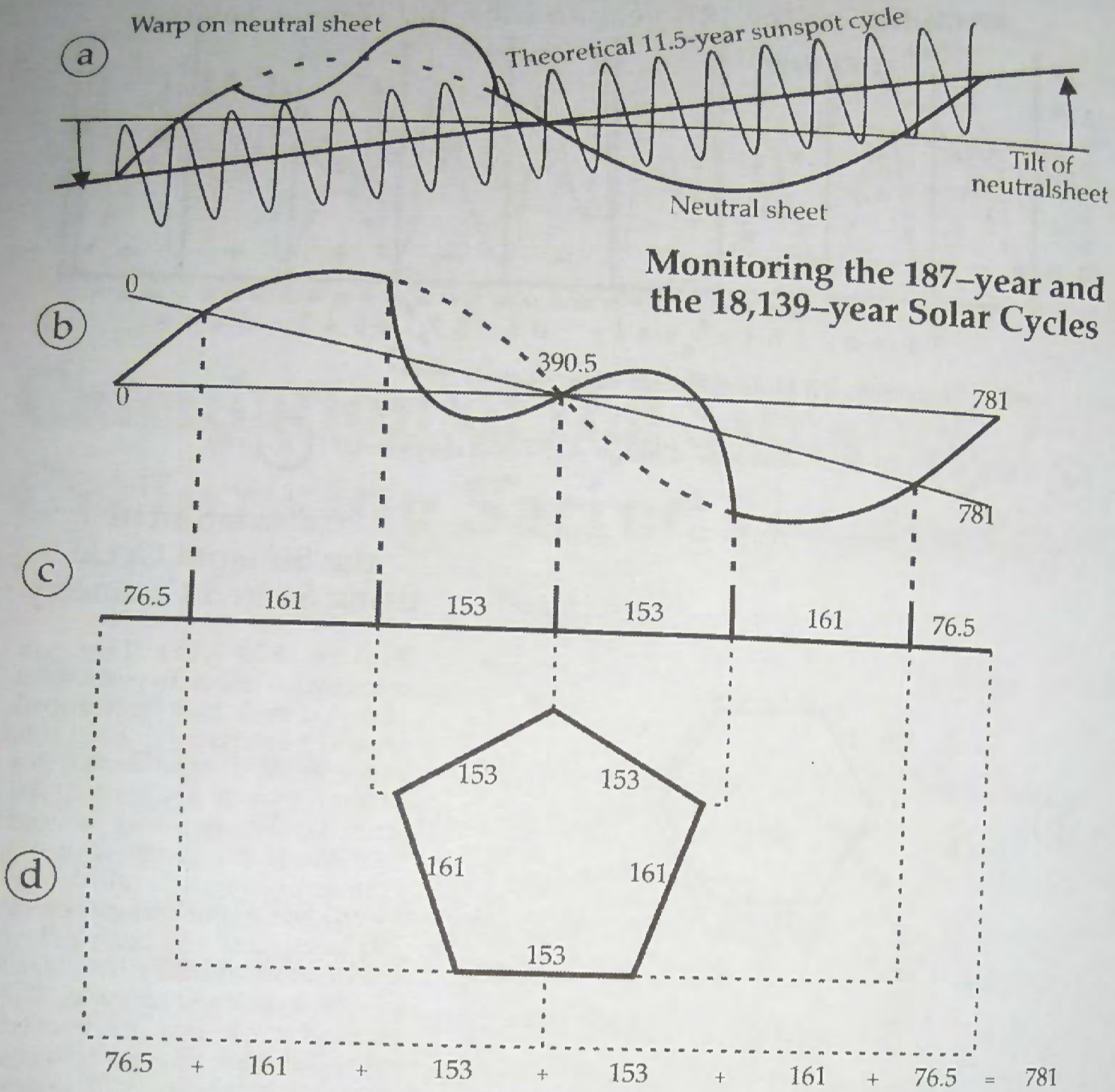

A30. (a) 11.5-year hypothesised sunspot cycle carried on the tilted neutral sheet. (b) Neutral sheet (rotated to facilitate projection). (c) Location of shift bit intersections along neutral sheet. (d) Pentagon showing distances between shift bits. The hexagon rollover method will track sunspot cycles but will begin to accumulate an error of one shift bit on encountering shift bit microcycles. To overcome this the hexagon can be placed inside a pentagon. (e) The pentagon is rolled over whenever insufficient space remains for one more hexagon rollover. In this way the 187-year sunspot cycle can be monitored accurately over the 18,139-year grand solar cycle.

Stonehenge III c. 1500 BC

(Note; Stonehenge I c. 3113 BC
Stonehenge II c. 2000 BC)

(b)

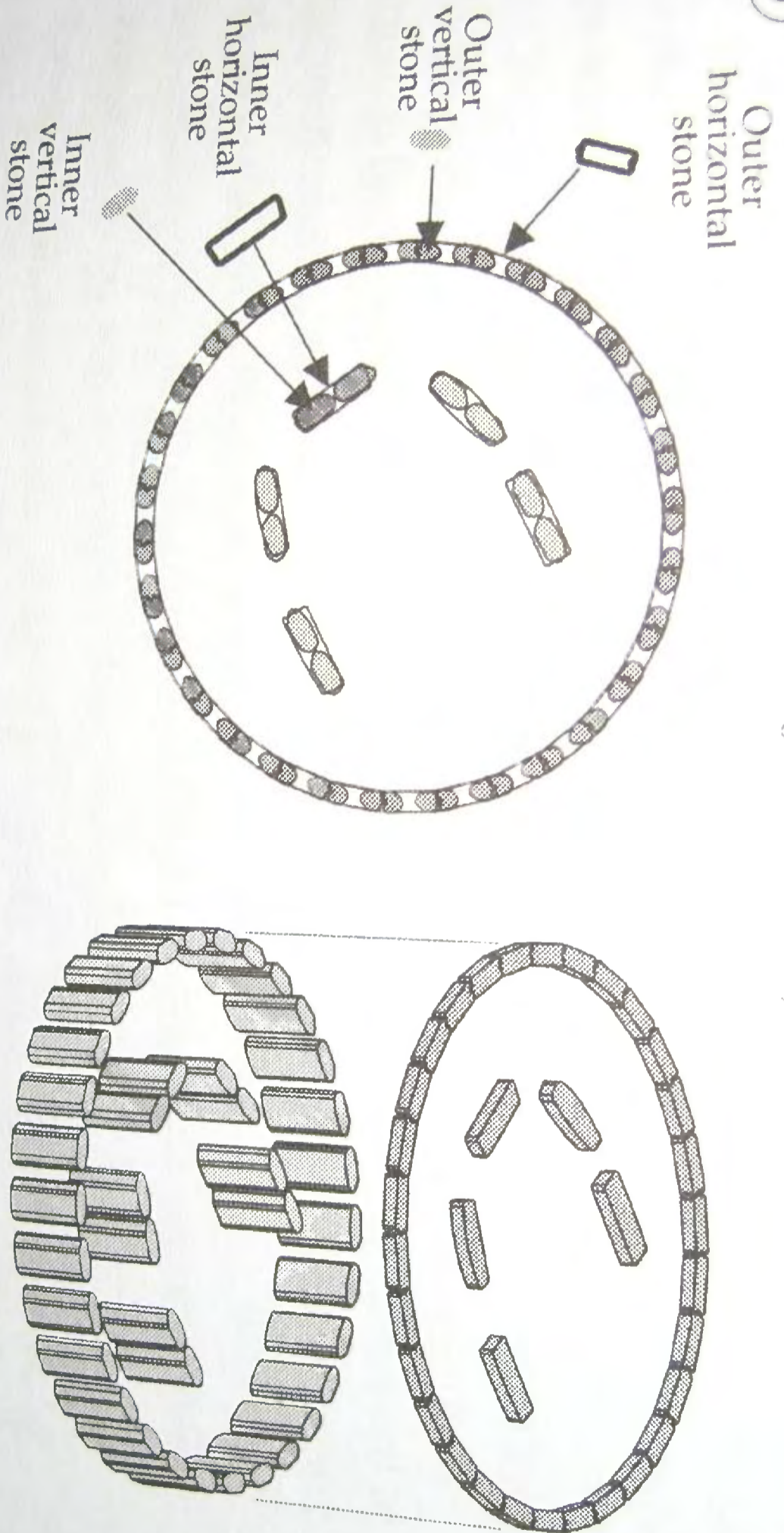

Figure A31. (a) The hexa-pentagon arrangement shows how the sunspot cycle can be monitored using hexagons (or octagons) in conjunction with a pentagon. These shapes were encoded by the Gothic Masons in their cathedral architecture during the medieval period. This formed the basis for Sacred Geometry, the geometric shapes built into the architecture of churches throughout Europe. (b) Stonehenge can be used to track the sunspot cycle: The trilithon arrangements (3-stone arches on both the outer ring and inner horseshoe ring) at Stonehenge are made up of 40 vertical stones and 35 horizontal stones (in total). If one stone is marked each day, then all stones would be marked after 1,400 days (40×35). The marking of stones could be used as a calendrical accumulator in conjunction with the hexa-pentagon method of sunspot calculation.

cle and the 187-year cycle cross-over and interfere with each other— [meaning that the microcycle is 9 bits long instead of 8]; five such shift bits occur during the 187-year cycle and are shown in A30c) dropping from the waveform figure A30b. From this point on, the simple hexagon will begin to accumulate a one-bit error with every shift bit encounter. Figure A30d shows that the distances between shift bits may be expressed by an irregular pentagon with sides of 153, 153, 161, 153 and 161 (781 in total).

The shift bit de-synchronisation, using the hexagon method of sunspot cycle measurement, may be overcome by placing the hexagon inside the irregular pentagon (figure A30e). The hexagon is rolled over as before. Because 153 and 161 are divisible by eight 'remainder 1', the rolling hexagon will eventually run out of space to roll over. Whenever this happens the pentagon rolls over (taking the hexagon with it). The de-synchronising shift bit is hence 'skipped' maintaining synchronism between the hexagon and the sunspot cycle (figure A31a). The same applies to an Octagon rollover sequence.

A simple calendar, like that in figure A31b, could be used to keep track of the accumulation of days; each day one stone, either vertical or horizontal is marked, on the arrangement of 40 vertical and 35 horizontal stones (40 x 35 = 1,400 = two sides of the hexagon). The hexagon is rolled-over two faces once all 1,400 have been marked.

Central Library, Henry Street,
An Lárleabharlann, Sráid Anraoi
Tel: 8734333

Bibliography

- Adès, Harry. *Celtic Art*, Paragon, 1999.
- Aidey, Dr W. Ross, 'Cell Membranes, Electromagnetic Fields and Intercellular Communication', Basar, E. (Ed.), from a paper presented at the International Conference on Dynamics of Sensory and Cognitive Processing in the Brain, Berlin, August 1987.
- Ashe, Geoffrey, *A Guidebook to Arthurian Britain*, Longman, 1980.
- Bain, George, *Celtic Art—the Methods of Construction*, Dover, 1973.
- Banck, Johanna, *Feine Tüche Für Den Fürsten*, Theiss Verlag, 2002.
- Biel, Jörg, *Experiment Hochdorf*, Archäologische Denkmalewr in Hessen 51, 1994.
- Biel, Jörg, *Das Rätsel der Kelten vom Glauberg*, Theiss Verlag, 2002.
- Biel, Jörg, *Der Fürst*, Theiss Verlag, 2002.
- Biel, Jörg, *Der keltenfürst von Hochdorf*, Theiss Verlag 1998.
- Barber, Elizabeth Wayland, *The Mummies of Urumchi*, W. W. Norton and Co 1999.
- Berresford Ellis, Peter, *The Ancient World of the Celts*, Constable & Robinson, 1998.
- Bettany, G.T., *The World's Religions*, Ward Lock & Co., 1890.
- Capon, E. and MacQuitty, W., *Princes of Jade*, Sphere, 1973.
- Cavendish, R., *An Illustrated Guide to Mythology*, W. H. Smith, 1984.
- Coghlan, Ronan, *The Encyclopaedia of Arthurian Legends*, Vega Books, 1991.
- Cotterell, Arthur and Storm, Rachel, *The Ultimate Encyclopaedia of Mythology*, Hermes House, 1999.
- Cotterell, Arthur, *Myths & Legends*, Cassell, 1992.
- Cotterell, Maurice, *Astrogenetics*, Brooks Hill Robinson & Co., 1988.
- Cotterell, Maurice, *The Amazing Lid of Palenque*, Vol. 1, Brooks Hill Perry & Co., 1994.
- Cotterell, Maurice, *The Amazing Lid of Palenque*, Vol. 2, Brooks Hill Perry & Co., 1994.

Monitoring the 187-year and the 18,139-year Solar Cycles Using Stonehenge

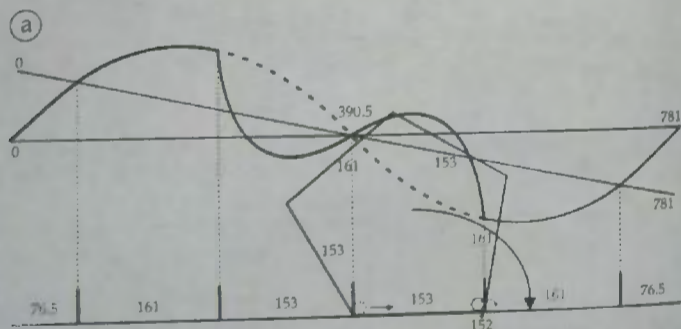

Stonehenge III c. 1500 BC

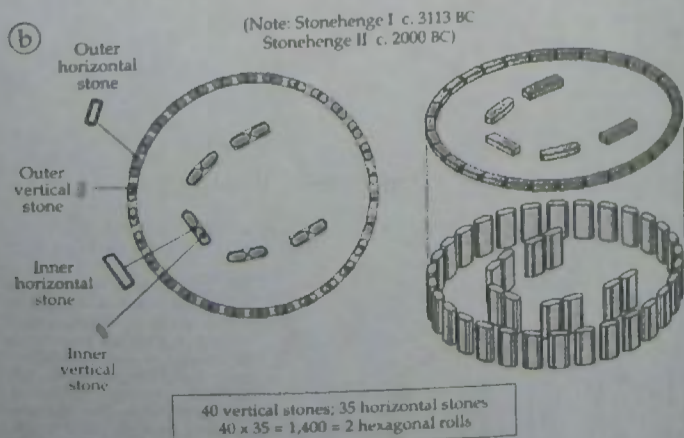

Figure A31. (a) The hexa-pentagon arrangement shows how the sunspot cycle can be monitored using hexagons (or octagons) in conjunction with a pentagon. These shapes were encoded by the Gothic Masons in their cathedral architecture during the mediaeval period. This formed the basis for sacred geometry, the geometric shapes built into the architecture of churches throughout Europe. (b) Stonehenge can be used to track the sunspot cycle. The trilithon arrangements (three-stone arches on both the outer ring and inner horseshoe ring) at Stonehenge are made up of 40 vertical stones and 35 horizontal stones (in total). If one stone is marked each day, then all stones would be marked after 1,400 days (40 x 35). The marking of stones could be used as a calendrical accumulator in conjunction with the hexa-pentagon method of sunspot calculation.

CALCULATION OF THE SUNSPOT CYCLE

other [meaning that the microcycle is 9 bits long instead of 8]—five such shift bits occur during the 187-year cycle and are shown (in A30c) dropping from the waveform figure A30b. From this point on, the simple hexagon will begin to accumulate a one-bit error with every shift bit encounter. Figure A30d shows that the distances between shift bits may be expressed by an irregular pentagon with sides of 153, 153 and 161 (781 in total).

The shift bit de-synchronisation, using the hexagon method of sunspot cycle measurement, may be overcome by placing the hexagon inside the irregular pentagon (figure A30e). The hexagon is rolled over as before. Because 153 and 161 are divisible by 8 'remainder 1', the rolling hexagon will eventually run out of space to roll over. Whenever this happens the pentagon rolls over (taking the hexagon with it). The de-synchronising shift bit is hence 'skipped', maintaining synchronism between the hexagon and the sunspot cycle (figure A31a). The same applies to an octagon rollover sequence.

A simple calendar, like that in figure A31b, could be used to keep track of the accumulation of days: each day one stone, either vertical or horizontal, is marked, on the arrangement of 40 vertical and 35 horizontal stones (40 x 35 = 1,400 = two sides of the hexagon). The hexagon is rolled over two faces once all 1,400 have been marked.

Monitoring the 187-year and the 18,139-year Solar Cycles Using Stonehenge

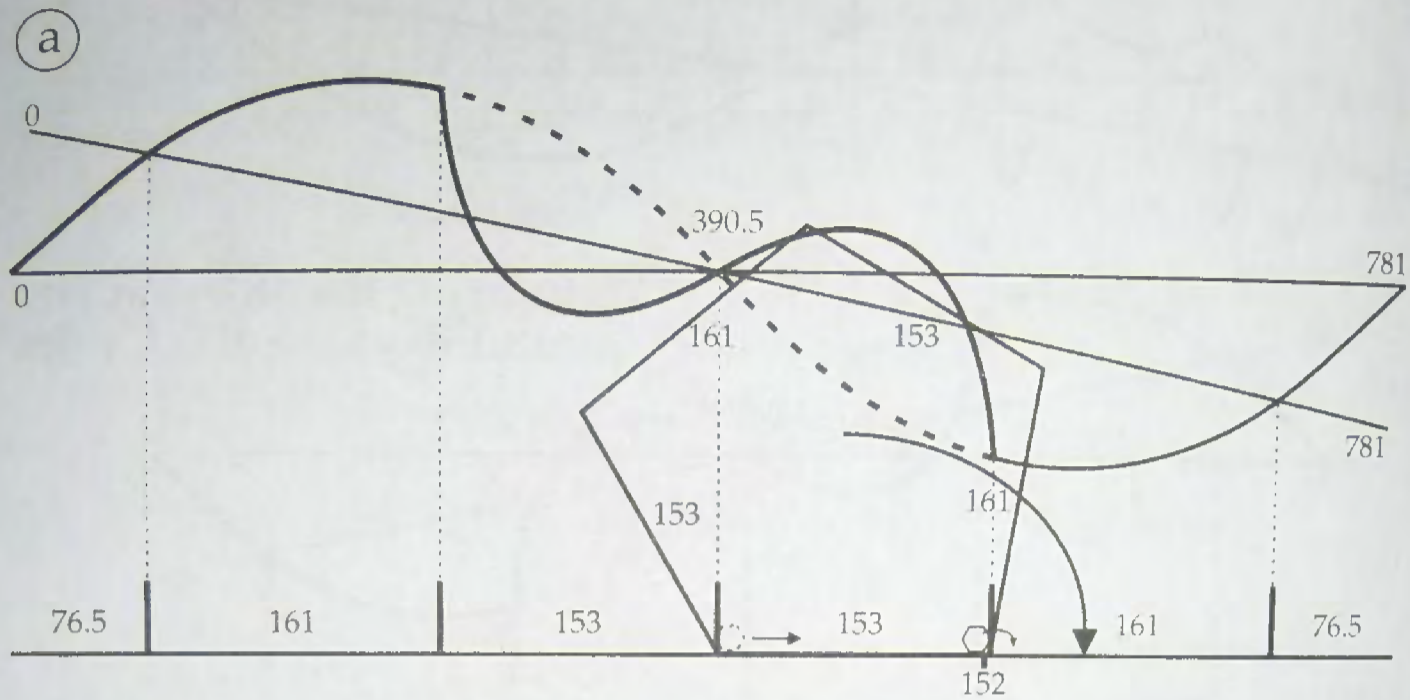

Stonehenge III c. 1500 BC

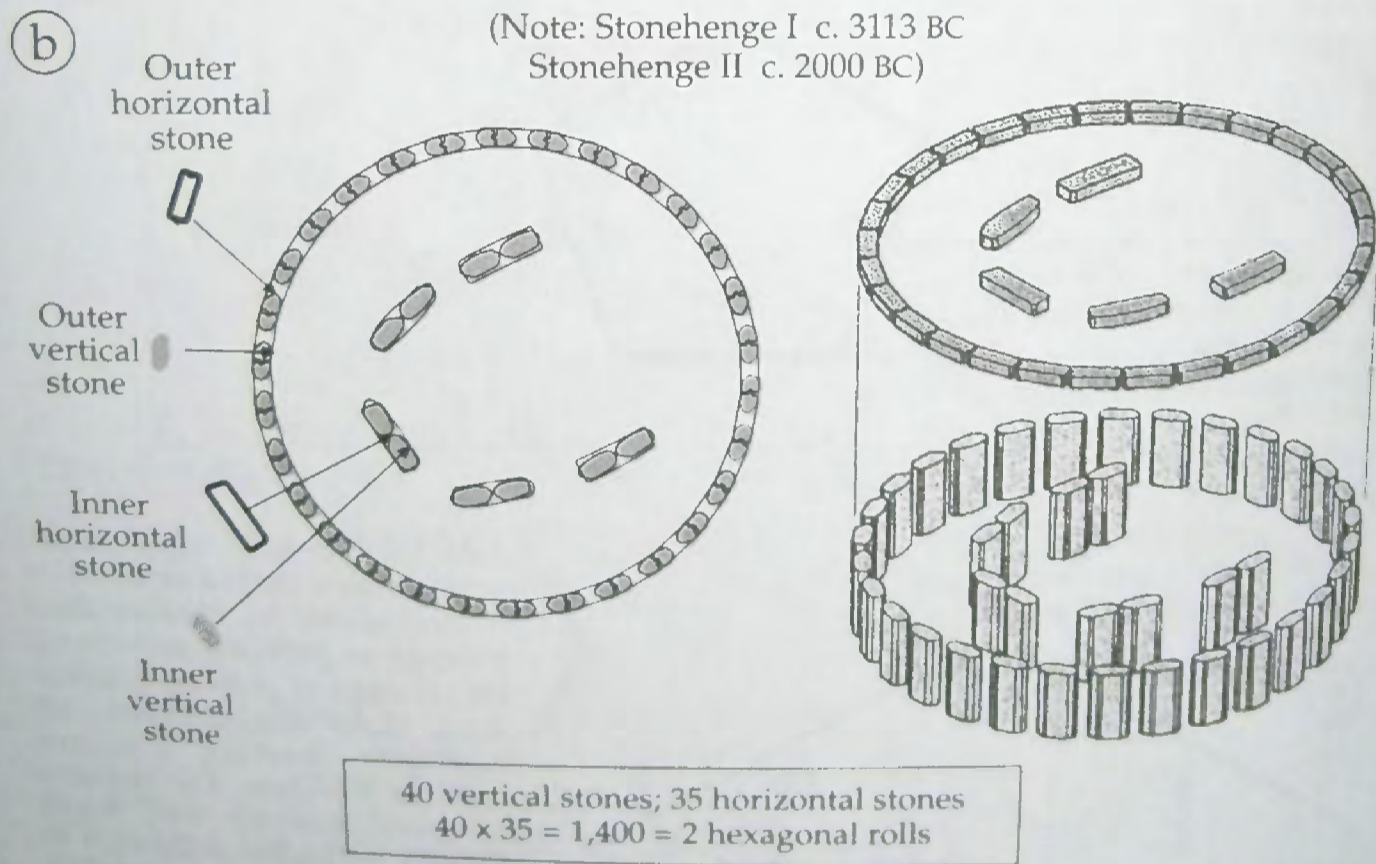

Figure A31. (a) The hexa-pentagon arrangement shows how the sunspot cycle can be monitored using hexagons (or octagons) in conjunction with a pentagon. These shapes were encoded by the Gothic Masons in their cathedral architecture during the mediaeval period. This formed the basis for sacred geometry, the geometric shapes built into the architecture of churches throughout Europe. (b) Stonehenge can be used to track the sunspot cycle: The trilithon arrangements (three-stone arches on both the outer ring and inner horseshoe ring) at Stonehenge are made up of 40 vertical stones and 35 horizontal stones (in total). If one stone is marked each day, then all stones would be marked after 1,400 days (40 x 35). The marking of stones could be used as a calendrical accumulator in conjunction with the hexa-pentagon method of sunspot calculation.

- Cotterell, Maurice. *The Mayan Prophecies*. Element, 1995 (co-authored).
- Cotterell, Maurice. *The Mosaic Mask of Palenque*. Brooks Hill Perry & Co., 1995.
- Cotterell, Maurice. *The Mural of Bonampak*. Brooks Hill Perry & Co., 1995.
- Cotterell, Maurice. *The Supergods*. Thorsons, 1997.
- Cotterell, Maurice. *The Lost Tomb of Viracocha*. Headline, 2001.
- Cotterell, Maurice. *The Tutankhamun Prophecies*. Headline, 1999.
- Cotterell, Maurice. *The Terracotta Warriors*. Headline, 2003.
- Dix, Gregory. *Jew and Greek—a study in the primitive Church*. New York, Harper & Bros. 1953.
- Beresford Ellis, Peter. *The Celts*. Constable & Robinson Ltd., 1998.
- Eysenck, H. J., and Nias, D. K. B., *Astrology: Science or Superstition?* Maurice Temple Smith, 1982.
- Finlay, Ian. *Celtic Art*. Noyes, 1973.
- Ghezzi, Bert. *The Times Book of Saints*. Harper Collins, 2000.
- Gibbon, Edward. *The History of the Decline and Fall of the Roman Empire*. Ed. J. B. Bury, 7 vols., Methuen, London, 1896–1900.
- Goetz, D. & Morley, S.G., *The Popol Vuh* (after Recinos). Wm. Hodge & Co., 1947.
- Green, Miranda. *The Gods of The Celts*. Sutton Books, 1986.
- Herm, Gerhard. *The Celts*. Weidenfeld and Nicolson, 1976.
- Hessisches Landesmuseum Darmstadt. *Katalog der Glauberg-Funde*. 1980.
- His Majesty's Special Command (trans.), *Holy Bible*. Eyre & Spottiswoode, 1899.
- Hitching, F. *The World Atlas of Mysteries*. Wm. Collins & Son, 1978.
- Horton, Fred L. Jnr., *The Melchizedek Tradition—a critical examination of the sources to the fifth-century A.D. and in the Epistle to the Hebrews*. Cambridge University Press, 1976.
- Hubert, Henri. *The History of the Celtic People*. Bracken Books, 1993.
- Hutchinson. *Encyclopedia*. Helicon, 1998.
- Jordan, M., *Encyclopaedia of Gods*. Kyle Cathie, 1992.
- Lafferty, P. and Rowe, J., (Ed.'s) *The Hutchinson Dictionary of Science*. Helicon, 1996.
- Laing, Lloyd and Jennifer. *Art of the Celts*. Thames and Hudson, 1992.
- Lalor, Brian (Ed.) *The Encyclopaedia of Ireland*. Gill Macmillan, 2003.
- Legge, James. *The Chinese Classic*. Volumes I-V. University of Hong Kong Press, 1960.
- le Plongeon, Augustus. *Sacred Mysteries among the Mayas and the Quiches 11,500 Years Ago*. Macoy, 1909.
- Mallory, J.P., and Mair, Victor H., *The Tarim Mummies*. Thames and Hudson, 2000.

- Morley, S.G., *An Introduction to the Study of Maya Hieroglyphs*. Dover, 1915.
- Moore, Hunt, Nicolson and Cattermole. *The Atlas of the Solar System*. Mitchell Beazley, 1995.
- Moon, Peter. *The Black Sun*. Sky (New York) 1997.
- Mac Airt, Sean (Ed.) *The Annals of Inisfallen*. Dublin Inst. for Advanced Studies, 1988.
- McLeish, Kenneth. *Myths and Legends of the World*. Blitz Editions, 1996.
- MacNeill, Eoin. *Celtic Ireland*. Martin Lester Ltd, Dublin, 1921.
- Musurillo, Herbert (Ed.), *The Acts of the Christian Martyrs*. Oxford Clarendon Press, 1972.
- Osborn, Eric. *The Beginning of Christian Philosophy*. Cambridge University Press, 1981.
- Pearson, R., *Climate and Evolution*. Academic Press, 1978.
- Peterson, Roland. *Everyone is Right - A new look at Comparative Religion and its Relation to Science*. De Vorss & Co (California), 1986.
- Philip's, *Atlas of the Celts*. George Philip Ltd, 2001.
- Pierpaoli, Walter and Regelson, William, with Colman, Carol. *The Melatonin Miracle*. Simon & Schuster, 1995.
- Posnansky, Arthur. *Tihuanacu, the Cradle of American Man*. J. J. Augustin, New York, 1945.
- Poynder, Michael. *Pie in the Sky*. Rider, 1992.
- Powell, Neil. *The Book of Change - How to understand the I Ching*. Orbis, 1979.
- Price, Glickstein, Horton and Bailey. *Principles of Psychology*. Holt Rinehart and Winston, 1982.
- Reiche, Maria. *Nazca Peru. Mystery of the Desert*. Hans Shultz-Severin, 1968.
- Reinhard, Johan. *The Nazca Lines: A New Perspective on their Origin and Meaning*. Editorial Los Pinos, 1985.
- Parker, Geoffrey. *The Times Atlas of World History*. Harper Collins, 1978.
- Ryan, M. (Ed.) *Treasures of Ireland*. Royal Irish Academy, 1983.
- Raftery, Barry (Ed.) *Atlas of the Celts*. Philips, 2001.
- Roys, Ralph R., *The Book of Chilam Balam of Chumayel*. University of Oklahoma Press, 1932.
- Rutherford, Ward. *Celtic Lore*. Thorsons, 1993.
- Scheitzer, Albert. *The Quest of the Historical Jesus*. trs. Wm. Montgomery. New York, Macmillan, 1961.
- Sharkey, John. *Celtic Mysteries*. Thames and Hudson, 1975.

Notes

Chapter One

1. In *Critias* and *Timaeus* c. 355 BC.
2. The Greek statesman c. 638 BC.
3. From the Greek word *Keltoi*—the 'secret people'.
4. The language derives from four main groups of a branch of Indo-European and is spoken in most of Europe. Gaelic and its close relatives Lepontic, Noric and Galatian were once spoken in a wide arc from France to Turkey and from the Netherlands to Italy and Celtiberian, once spoken in Spain, are now long obsolete. The third in the group, the Brythonic, or P-Celtic, is spoken by the Welsh, Cornish, Bretons and Gauls [of France] whereas the Goidelic, or Q-Celtic, is spoken by the Irish [Gaelic, from the association with the French, Gaul], the Scots and the Manx of the Isle of Man. The extinct and the contemporaneous are often classified as two branches, but competing schemes prefer different combinations.
5. Deoxyribonucleic acid—the giant molecule that makes the building blocks of biorganisms.
6. The Germanic invaders who conquered much of Britain between the 5th and 7th centuries and who pushed the Celts westwards across Britain.
7. Believed to have been compiled in the monastery of Inisfallen between 1056 and 1092. The monastery was established in around AD 650 on the 23-acre island of Innisfallen [the modern-day spelling differs slightly] in the lower Killarney Lake, County Kerry, Ireland. The transcript of the *Annals*, up to 1092, is believed to have been used at a monastery at Lissom and compiled from earlier documents maintained at the monastery of Emly. It was probably continued at Lissom until between around 1130 to 1159 when it was passed to South Munster, probably Inisfallen.
8. Northwest of the Black Sea between the Carpathian Mountains and the River Don.

NOTES

9. There were five sons of Míl altogether: Éremón, Donn, Ír, Éber and another (the name of the fifth does not appear in the translation because of damage to the original manuscript). Éber was born in Egypt, Donn was born in Scythia and Ír and Éremón, the youngest two, were born in Spain.
10. The *Annals* state that the 'Scotti' were converted to the Christian faith [in AD 433]. *The Encyclopaedia of Ireland* [under the heading of 'Scotland, links with'] says that later 'an expedition led by the three sons of Erc from Irish Dal Ráda (in County Antrim, Ireland) founded the Kingdom of Argyll (now Scotland) in around AD 500'. Hence the origin of Ir-land (after Ír the son of Míl) and Scotland (after Scotta, the Pharaoh's daughter).
11. So named after *hall*, the Celtic word for salt, and *statt*, the Celtic word for place.
12. *The Tutankhamun Prophecies* sets out in detail just how the twenty-eight-day solar radiation cycle correlates with variations in fertility hormones.
13. Paleomagnetic evidence, from Pearson and Cox (*Climate and Evolution*, 1978), and tree ring data from Bucha, 1970 [both documented in *The Mayan Prophecies*], suggest that the Sun's magnetic field shifted in 3113 BC and again in around AD 620 (1,366,040 days after the 3113 BC shift). It appears that the magnetic twist of AD 620 was of insufficient strength to tilt any of the planets off their axis but did result in adverse radiation from the Sun that deleteriously affected the Earth (see main text).
14. Areas around the Earth's equator are struck by more perpendicular solar X-rays and are hence more affected.
15.
 - They were all born through an Immaculate Conception.
 - Buddha's mother's name was Maya. Maya was the name of the architect of Tutankhamun's tomb, and also the name of his wet-nurse. The word Maya means 'illusion' in ancient Sanskrit.
 - Maya was a culture that flourished in Mexico c. 100–750 AD and Lord Pacal, the priest-king leader of the Maya, taught that this life was illusion.
 - Krishna is the Greek word for the 'anointed one' and Christ anointed (baptised) others.
 - Jesus is known as the Son of God [from the Tibetan Chi, (godly energy) and the Greek Zeus, the creator God, Chi Zeus, the Son of God who died c. 32 BC. [The Bible says: '... the angel of the Lord appeared unto Joseph in a dream saying... Mary shall bring forth a son and his name shall be Chi Zeus', *Matthew* 1, 20–21]; the name Tut-ankh-amun translates into 'the living image of God'—the Son of God—and Ch'in Shi Huangdi, the first emperor of unified China, was known to his people as the 'Son of Heaven'.
 - Stories left behind by Lord Pacal (from the Mural of Bonampak) say that

- Shri Purohit Swami. *The Geeta*. Faber & Faber, 1935.
- Sykes, Egerton. *Dictionary of Non-Classical Mythology*. J. M. Dent, 1952.
- Talbot Rice, David. *The Dark Ages*. Thames & Hudson, 1965.
- Thomson, W. A. R.. *Black's Medical Dictionary*. A. & C. Black, 1984.
- Thorpe, Lewis. (trs.) Geoffrey of Monmouth (c. 1136) *The Kings of Britain*. Penguin, 1973.
- Von Hagen, W.. *The Ancient Sun Kingdoms of the Americas*. Thames and Hudson, 1962.
- Wallace, P. F. & Ó Flóinn Raghnaill (Ed's.) *Treasures of the National Museum of Ireland*. Gill & Macmillan, 2002.
- Willis, Roy (Ed.). *World Mythology—the illustrated Guide*. Platkus, 1993.
- Warner, R. (Ed.). *Encyclopaedia of World Mythology*. BPC, 1970.
- Wegener, G. S.. *6,000 Jahre und ein Buch*. Oncken Verlag Kassel, 1958.
- Welker, H. A., Semm, P., Willig, R.P., Wiltschko, W., Vollrath, L.. *Effects of an artificial magnetic field on serotonin-N-acetyltransferase activity and melatonin content of the rat pineal gland*. *Exptl. Brain Res.* 50:426–531, 1983.
- White, J.. *Pole Shift*. ARE Press (USA), 1993.
- Willis, Roy (consultant). *Dictionary of World Myth*. Duncan Baird, 1995.
- Zaczek, Iain. *The Art of the Celts*. Parkgate Books, London, 1997.
- Zaczek, Iain. *Chronicles of the Celts*. Collins & Brown, 1996.

Index

- Abraham 56
 Abraham, Dr Carl 61
 Absalom 62
 Acts of the Apostles 88
 Adomnan 99
 Agricola, Governor 47
 Ahab 64
 Aidan, St 100
 Aidey, Dr Ross 11
 Akhenaten 60, 61
 Alban, St 91
 Alesia 47
 Alpha 151
 Alpine 7
 Amazing lid of Palenque 42, f21
 Amber 27, 36,
 Amenophis III 60
 Amos 64, 68
 Anglo-Saxons 2
 Apocrypha 67
 Apollo 41,
 Apostles, twelve 72, 179
 Ardagh Chalice P16, P19, P20,
 P23, 109, 137, 139, 140, Ch.5
 Ardagh Hoard 137, 138, 139
 Aramathea, Joseph 69, 75, 84, 92,
 121, 177, 179
 Argumenta 104
 Ark of the Covenant 62
 Art-Deco 61
 Arles, Council of 91
 Arthanasius 92
 Arjuna 17, 123
 Artemis 41,
 Arthur, King 116, 121, f40, f41,
 124, 129, 136, 139, 156, 177, 180
 Arthurian legend P17 P20, 116,
 117, 119, 125, 130, 136, 140, 176
 Aryans 2
 Assyrians 64
 Astrology f8, 85
 Athenaeus 48,
 Atlantis 1
 Atum 57
 Augustus, Emperor 48,
 Augustus, Caesar 68
 Aztec(s) 49,
 Babbist, John the 72, 118
 Babylonians 64, 65
 Patriarchs 64

229

NOTES

- he was the Lord of Sacrifice who died on a cross-made from two pieces of wood. Jesus died on the cross at Easter and the Roman Catholic word for Easter is Paschal.
- Viracocha is the Quechua word for 'foam of the sea', a metaphor for the perfect human being. A person in 'the foam of the sea' is simultaneously in contact with all of the Earth's elements of earth, air, fire and water: the earth, beneath the feet; the air; the fire (the Sun) that shines on the face; and the water. Any movement towards the sea causes loss of contact with the earth. Any movement towards the land causes loss of contact with the water. Hence, a person reaches perfection only in the 'foam of the sea'. A 60-cm- (2 foot-) high golden anthropomorphic figure of a crab-man (plate 5d) was found in the tomb of Viracocha at Sipan in Peru. The crab is a creature that lives on the land and in the sea, in the foam of the sea.
 - The Brahmans, of India, believe Heaven to be a 'milky ocean' (foam of the sea) which is why they believe the cow to be sacred.
 - All of the Supergods—Krishna, Tutankhamun, Buddha, Ch'in Shi Huangdi, Jesus, Viracocha (and Viracocha Pachacamac) and Lord Pacal—performed miracles.
 - When they died they all became Venus.
16. The Indian Vedas (divine knowledge of the Brahmans) tell of the Indian holy trinity: Brahma (the Holy Ghost, or spirit), Vishnu (the flesh, incarnate on Earth) and Siva (the father). Vishnu is said to have incarnated on Earth nine times, the eighth time as the Hindu God Lord Krishna and the ninth as Lord Buddha. The Vedas are believed to have been written by the Indo-Aryans prior to their entering India in around 1500 BC. The four main Vedas are: the Rig-Veda (hymns and praises); Yajur-Veda (prayers and sacrificial formulae); Sama-Veda (tunes and chants); and Atharva-Veda of the Atharvans, the officiating priests at the sacrifices. They are all written in an old form of ancient Sanskrit.
17. Stories from the sun shield of Monte Albania (plate 3c) show Lord Pacal reincarnating as Venus.
18. The 'bright' star refers to the bright star in the dark night sky (the evening star) as against the 'morning star' that competed with the rising sunlight and hence was less bright.
19. The plural for 'fibula', used to describe a safety-pin-style cloak fastener.
20. When found the carriage was crushed, requiring extensive restoration and reconstruction.
21. The formal period in pre-history during which bronze was most favoured

226

NOTES

22. Previously featured in *The Lost Tomb of Viracocha and The Terracotta Warriors*.
23. The technique is often compared to the later technique of cloisonné, the ornamental craft in which metal strips are soldered into a pattern on a metal surface and the resulting compartments (cloisons) filled with coloured enamel and then fired.
24. *Encyclopaedia of World Mythology*, Octopus, 1975.
25. *Encyclopaedia of Myths and Legends*, Arthur Cotterell, Cassell, 1989.
26. Governed Britain AD 78–85.
27. In *Natural History*, published in around AD 50, the Roman scholar Pliny the Elder (AD 23–79) describes the pagan oak tree ritual '... clad in white robes, the priest climbs a tree and with a golden sickle cuts a sprig of mistletoe'. *Pharsalia* [c. 48 BC], Loeb, 1962.
28. The Universal Law of action and reaction.
29. The National Museum of Ireland has dozens of examples like these.

Chapter Two

30. Who may have been one and the same as King Menes.
31. See *The Tutankhamun Prophecies: 'The Mystery of the mixed-up meat'*.
32. Asher, Benjamin, Dan, Ephraim, Gad, Issachar, Judah, Mandasseh, Naphtali, Reuben, Simeon, and Zebulun.
33. The body of books accepted by the Church.
34. *The Times* (review article), April 10, 2004.
35. An Island Dependency of the U.K. located in the Irish Sea.
36. Fifty days after the Jewish festival of Passover [the eight-day spring festival that commemorates how the Angel of Death passed over Jews houses, so that only the Egyptian firstborn sons were killed—which is seen as divine retribution, following the Pharaoh's edict that all male Jewish infants should be killed].
37. *The Ultimate Encyclopaedia of Mythology*, Arthur Cotterell, Hermes House, 1999, p. 13.
38. Bede's *Ecclesiastical History of the English People*. Ed. B. Colgrave and R. A. B. Mynors (Oxford 1969), IV. 4.

Chapter Three

39. So-called because the first letter of each column was often 'illuminated' in red, *ruber* (Latin).
40. Easter, commemorating the crucifixion of Jesus, coincides with the Jewish festival of Passover. The so-called Easter Controversy refers to the dispute concerning the preferred dating of the Easter festival. The Jews calculate

227

22. Previously featured in *The Lost Tomb of Viracocha* and *The Terracotta Warriors*.
23. The technique is often compared to the later technique of cloisonné, the ornamental craft in which metal strips are soldered into a pattern on a metal surface and the resulting compartments (cloisons) filled with coloured enamel and then fired.
24. *Encyclopaedia of World Mythology*, Octopus, 1975.
25. *Encyclopaedia of Myths and Legends*, Arthur Cotterell, Cassell, 1989.
26. Governed Britain AD 78–85.
27. In *Natural History*, published in around AD 50, the Roman scholar Pliny the Elder (AD 23–79) describes the pagan oak tree ritual '... clad in white robes, the priest climbs a tree and with a golden sickle cuts a sprig of mistletoe'. *Pharsalia* [c. 48 BC], Loeb, 1962.
28. The Universal Law of action and reaction.
29. The National Museum of Ireland has dozens of examples like these.

Chapter Two

30. Who may have been one and the same as King Menes.
31. See *The Tutankhamun Prophecies: 'The Mystery of the mixed-up meat'*.
32. Asher, Benjamin, Dan, Ephraim, Gad, Issachar, Judah, Mandasseh, Naphtali, Reuben, Simeon, and Zebulun.
33. The body of books accepted by the Church.
34. *The Times* (review article), April 10, 2004.
35. An Island Dependency of the U.K. located in the Irish Sea.
36. Fifty days after the Jewish festival of Passover [the eight-day spring festival that commemorates how the Angel of Death *passed over* Jews houses, so that only the Egyptian firstborn sons were killed—which is seen as divine retribution, following the Pharaoh's edict that all male Jewish infants should be killed].
37. *The Ultimate Encyclopaedia of Mythology*, Arthur Cotterell, Hermes House, 1999, p. 13.
38. Bede's *Ecclesiastical History of the English People*. Ed. B. Colgrave and R. A. B. Mynors (Oxford 1969), IV. 4.

Chapter Three

39. So-called because the first letter of each column was often 'illuminated' in red, *ruber* (Latin).
40. Easter, commemorating the crucifixion of Jesus, coincides with the Jewish festival of Passover. The so-called Easter Controversy refers to the dispute concerning the preferred dating of the Easter festival. The Jews calculate

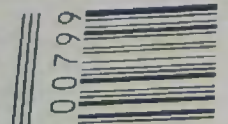

concealed
the higher
Maurice
ions which
d in my life
outsider

Baden-Wuerttemberg 17
 Bain, George f34, f35, 108, 110, f37
 Basil 91
 Bas relief 15, f9
 Basse Yutz f3 35, 36, 38, 151
 Basse Yutz flagons P14, P14, 110, 139, 177
 Bat God P8, 5, 24, 31, f44
 Bede 93
 Bedivere 121, f40, f41
 Bel and the Dragon 67
 Benedict 91
 Bethlehem 69
 Bhagavad Gita 17, 81, 123
 Biel, Dr Joel 17
 Birth of Venus 14
 Blair, Edmund 125
 Blake, William 69
 Bonampak 32
 Boniface, St 98
 Boudicca 47
 Bowl and Girdle 149, 151
 Bowl girdle panels f50
 Bowl girdle, stud mountings f57
 Brahma 55
 Brahmans 54, 55,
 Breisach f15
 Breves Causae 104
 Bridle f14
 Brotherhood 125
 Bronze-Age 27
 Buddha 14, 54, 55,
 Burne-Jones, Edward P17, 125, 129
 Butler, Dr 141
 Byzantine 93, 105, 141, 179
 Byzantium 93
 Caicher 2
 Camp de Chassey f15, 29
 Carter, Howard 59, 60
 Carving, secrets of 155
 Caucasians 1
 Caryatid 22, f13, 24

230

Cassivellaunus 46
 Cathach 103
 Cathach of St Columba 105
 Cernunnos 38, f20, 41, f22, 45, 133
 Caesar, Julius 46, 47, 48, 49
 Calderon, William Frank 125
 Canaan 2, 56, 59, 61, 65
 Canon Tables 104, 105
 Carpet Pages 102, 105,
 Caspian Sea 2
 Celestine, Pope 99
 Cernunnos P22
 Chakra 85,
 Chalice engraving f55
 Champlévé 37,
 Chatillon-sur-Glane f15
 Châtillon-sur-Seine 17
 Cherchen f1a
 Chrétien de Troyes 117, 118, 123
 Checkers 63
 Chi Zeus 41, 54
 Ch'in Shi Huangdi 45, 54, 112, f39, 124, 134
 Chronicles, the First Book of, 68
 Chronicles, the Second Book of, 68
 Cinnabar 15
 Claudius, Emperor 47
 Cloisonné 55
 Clusium 45
 Codex Carolinus 98
 Codex Victor 98
 Codex Usanianus 103
 Coligny 48, 143
 Colm Cille 99
 Columba, St 99, 100, 105
 Compasses, freemason P7 P8
 Conjoined dragons f52-f54
 Constantine the Great 91, 93
 Confucius 9
 Continuous-line drawing 106, f35, f36, 107, 108, f37, 139
 Copycat monks 173, f64

Cornwall 71
 Cranfield University 14
 Critias and Timaeus 53
 Crystal, foot cone, secrets of, f59
 Cyrus 65
 David, King 62, 63,
 Danann 2
 Daniel 66, 67, 68
 De Grance, Leon 120, f41
 De Leon, Cleza 188
 Delphi 41, 46, f1b, f3
 Derrynaflan Hoard f63 171, 172, 181
 Dendera 58
 Deuteronomy 68
 Dicksee, Leighton Frank 125
 Diodorus 48
 Divine Reconciliation, General theory of 74, fA18, fA19, fA20, 187
 DNA 2, f12, 50, 53
 Domitian, Emperor 47
 Donn 2, 53, 54
 Dragon-angels P19, 130, 140
 Dragonhead P21, P22, 133, 134, 139
 Dragons, secrets of 155
 Draughts 63
 Dresden Codex 14
 Drudic 5, 48, 143
 Druidism 47,
 Druids 47, 50
 Durraven, Lord 141, 142, 150, 151
 Durrow 99, 102, 104, 105, 109, Éber 53, 54,
 Ecclesiastes P18, 63, 68, 138
 Ecclesiasticus 67
 Ector, Sir 120
 Echnach Gospels 112
 Ecumenical Council 92
 Elijah 64
 Elisha 64
 Emly 53,
 Enda, St 99
 Ephraim 91
 Episcopal 99
 Epistles 89
 Erémón 53, 54
 Esther 68
 Ethelbert, King 99
 Ethewald 103
 Eucharist 118
 Eugippius 112
 Euphrates 56, 59
 Excalibur P19, P20, 119, 120, 121, 123, 130, 192
 Existence, General theory of 74, fA18, fA19, fA20
 Exodus 62, 64, 66, 68
 Ezekiel 64, 68
 Fair Rosamund P18, 125, f42, P18
 Fertility, God of 5
 Feathered snake 216-219
 Finnian, St 99
 Fisher King 117, 118
 Flanagan, Paddy 141
 Foot-cone 147, f49, 180
 Freud, Sigmund 61
 Galahad, Sir 93, 121, f40, f41, 179
 Gateway of the Sun 15, f9, P2, fA4
 Gawain f40, f41
 Geoffrey of Monmouth 117, 119
 Genesis 67
 Gerald of Wales 100
 Glastonbury 92, 129
 Glauberg 30, 31, 32, f3, f16,
 Gleninsheen Gorget f23
 God, first picture of, P24
 Gorlois 119, 120
 Gospels 68, 98, 102, 104, 105,
 Grammar, mystery of 155
 Gregory I, Pope 99
 Gregory II, Pope 98
 Guinevere 120, 121, f40, 124, 130
 Gundestrup cauldron 38, f19, f20, 42, f21, 133

231

NOTES

the date of Passover as occurring on a full moon. Christians knew only that the Crucifixion coincided with Passover and that it occurred at some time after the spring equinox (the 21st March) and on a Sunday. In order to ascertain a date for Easter, the Christians therefore had to synthesise the days and dates of Passover, the full moon, the spring equinox and the day of Sunday. This means that Easter Sunday falls on the first Sunday following the full moon that follows the spring equinox, meaning that Easter falls on a different date every year. The Irish Celts had their own way of doing the calculation but fell into line in AD 632. Northumbria (Lindisfarne) conformed in AD 664, Iona in AD 716 and the Welsh Church by AD 768.

41. However, an account from Prosper of Aquitaine's reliable *Chronicon* of AD 431 says that 'Pope Celestine ordained Palladius sending him to the Irish believers in Christ as their first Bishop. . . . Later writers, such as Muirchu, anxious to respect Palladius, yet wishing to present Patrick as the first Bishop, imagined Palladius failing in his task, being succeeded by Patrick, hence the dating of Patrick's arrival [as Bishop] at AD 432'. (quoted from *The Encyclopaedia of Ireland*, Gill & Macmillan, 2003)

Chapter Five

42. Isidori Hispalensis Episcopi *Etymologiarum sive Originum*, ed. W. M. Lindsay, 2 vols., Oxford, 1911, Vol. 2 lib XII vii.48.
 43. These Supergods knew of their impending death, as a passage from the Popol Vuh implies: 'They were endowed with intelligence; they saw and instantly they could see far, they succeeded in seeing, they succeeded in knowing all that there is in the world. When they looked, instantly they saw all around them, and they contemplated the arch of the heavens and the round face of the Earth. The things hidden (in the distance) they saw all, without first having to move; at once they saw the world. . . . Great was their wisdom'. (*The Popol Vuh*, Della Goetz and Sylvanus G. Morley, University of Oklahoma Press, 1947)

Bibliography

- Ades, Harry, *Celtic Art*, Paragon, 1999.
 Aidey, Dr. W. Ross, 'Cell Membranes, Electromagnetic Fields and Intercellular Communication', Basar, E. (ed.), from a paper presented at the International Conference on Dynamics of Sensory and Cognitive Processing in the Brain, Berlin, August 1987.
 Ashe, Geoffrey, *A Guidebook to Arthurian Britain*, Longman, 1980.
 Bain, George, *Celtic Art - the Methods of Construction*, Dover, 1973.
 Banck, Johanna, *Feine Tuche Für Den Fürsten*, Theiss Verlag, 2002.
 Barber, Elizabeth Wayland, *The Mummies of Urumchi*, W. W. Norton and Co., 1999.
 Berresford Ellis, Peter, *The Ancient World of the Celts*, Constable & Robinson, 1998.
 Bettany, G. T., *The World's Religions*, Ward Lock & Co., 1890.
 Biel, Jörg, *Experiment Hochdorf*, Archäologische Denkmalewr in Hessen 51, 1994.
 ———, *Das Rätsel der Kelten vom Glauberg*, Theiss Verlag, 2002.
 ———, *Der Fürst*, Theiss Verlag, 2002.
 ———, *Der Keltenfürst von Hochdorf*, Theiss Verlag, 1998.
 Capon, E., and MacQuitty, W., *Princes of Jade*, Sphere, 1973.
 Cavendish, R., *An Illustrated Guide to Mythology*, W. H. Smith, 1984.
 Coghlan, Ronan, *The Encyclopaedia of Arthurian Legends*, Vega Books, 1991.
 Cotterell, Arthur and, Rachel Storm, *The Ultimate Encyclopaedia of Mythology*, Hermes House, 1999.
 Cotterell, Arthur, *Myths & Legends*, Cassell, 1992.
 Cotterell, M. M., *Astrogenetics*, Brooks Hill Robinson & Co., 1988.
 ———, *The Amazing Lid of Palenque*, vol. 1, Brooks Hill Perry & Co., 1994.
 ———, *The Amazing Lid of Palenque*, vol. 2, BHP & Co., 1994.
 ———, *The Mayan Prophecies*, Element, 1995 (coauthored).

229

Habakkuk 64, 68
 Haggai 65, 68
 Hallstatt 7, 14, 17, 20, 27, 31, 35, 37, 84, 139, 182
 Handle escutcheon plates 169
 Hathor f6
 Han tomb P11
 Hebrew(s) 2, 56, 61, 65.
 Heidelberg 31
 Hengist 93
 Herod, King 69
 Heroditus 117
 Heshbon 64
 Heuneburg f15
 Hill-fort f15, 29, 30, 36, 45, 47.
 Hochdorf f3, 18, f10, 28, 53.
 Hochdorf, King of f13, f14, 27, 180
 Hohenasperg f15
 Holman Hunt, William 125
 Holy Grail P17, P19, P23, 92, 93, 117, 119, 121, 124, 125, 130, 140, Ch. 5
 Horsa 93
 Hosea 64, 68.
 Hughes, Arthur 125
 Hyksos 58
 Igraine, Queen 119, 120, f40
 Information, encoding of 205
 Insular majuscule 103, 105, 142, 174
 Illuminated manuscripts 100, 108, 179, 180
 IMP I f7
 Indo-Aryan 55
 Initial Pages 102, 105.
 Jona 99, 102, 103
 Irenaeus 90
 Inisfallen 53.
 Isaiah 64, 68
 Ír 53, 54
 Irish World Chronicles 2
 Isle of Man 84
 Israel 64

232

BIBLIOGRAPHY

- , *The Mosaic Mask of Palenque*, BHP & Co., 1995.
 ——, *The Mural of Bonampak*, BHP & Co., 1995.
 ——, *The Supergods*, Thorsons, 1997.
 ——, *The Lost Tomb of Viracocha*, Headline, 2001.
 ——, *The Tutankhamun Prophecies*, Headline, 1999.
 Dix, Gregory, *Jew and Greek—A Study in the Primitive Church*, New York: Harper & Bros., 1953.
 Egerton Sykes, *Dictionary of Non-Classical Mythology*, J.M.Dent and Sons, 1952.
 Eysenck, H.J., and, D. K. B. Nias, *Astrology: Science or Superstition?* Maurice Temple Smith, 1982.
 Finlay, Ian, *Celtic Art*, Noyes, 1973.
 Ghezzi, Bert, *The Times Book of Saints*, HarperCollins, 2000.
 Gibbon, Edward, *The History of the Decline and Fall of the Roman Empire*, ed. J. B. Bury, 7 vols., London: Methuen, 1896–1900.
 Goetz, D., and, S. G. Morley, *The Popol Vuh* (after Recinos), Wm. Hodge & Co., 1947.
 Green, Miranda, *The Gods of the Celts*, Sutton Books, 1986.
 Herm, Gerhard, *The Celts*, Weidenfeld and Nicolson, 1976.
 Hessisches Landesmuseum Darmstadt, *Katalog der Glauberg-Funde*, 1980.
 His Majesty's Special Command (translation), *Holy Bible*, Eyre & Spottiswoode, 1899
 Hitching, F. *The World Atlas of Mysteries*, Wm. Collins & Son, 1978.
 Horton, Fred L. Jr., *The Melchizedek Tradition—A Critical Examination of the Sources to the Fifth-century A.D. and in the Epistle to the Hebrews*, Cambridge University Press, 1976.
 Hubert, Henri, *The History of the Celtic People*, Bracken Books, 1993.
 Hutchinson, *Encyclopedia*, Helicon, 1998.
 Jordan, M., *Encyclopaedia of Gods*, Kyle Cathie, 1992.
 Lafferty, P., and, J. Rowe, (eds.) *The Hutchinson Dictionary of Science*, Helicon, 1996.
 Laing, Lloyd, and Jennifer Laing, *Art of the Celts*, Thames and Hudson, 1992.
 Lalor, Brian (ed.), *The Encyclopaedia of Ireland*, Gill Macmillan, 2003.
 Legge, James, *The Chinese Classic*, vols. I–V, University of Hong Kong Press, 1960.
 le Plongeon, Augustus, *Sacred Mysteries among the Mayas and the Quiches 11,500 Years Ago*, Macey, 1909.
 Mallory, J. P., and, Victor H. Mair, *The Tarim Mummies*, Thames and Hudson, 2000.
 Mac Airt, Seán (ed.) *The Annals of Inisfallen*, Dublin Institute for Advanced Studies, 1988.

233

Israelites P15, 61.
 Iterative Spiritual Development, General theory of 74, fA18, fA19, fA20, 97, 112
 Ivinghoe Beacon 30
 Jade suit 135, f44, P21
 Jehova 61, 89
 Jehu 64
 Jeremiah 64, 68
 Jeremiah, The Lamentations of 68
 Jerome 92, 104, 105
 Job 68
 John, Gospel of 88, 90
 Joel 48
 Jonah 64, 68
 Joseph 68
 Joshua 62, 68
 Judah 64
 Judaism 15, f9, 19
 Judges 62, 68
 Kalasassaya 192, fA3
 Kanes 59
 Katzenbuckel 35
 Karma 98
 Karmic 48,
 Kay f40, f41
 Kells 102, 103, 104, 105, 109, 110, 112, 115, 142
 Keltoi 53.
 King Arthur P17
 Kings the First Book of, 68
 Kings, the Second Book of, 68
 Kleinaspergle 35
 Knights of the Round Table 93, 119, f41, 156, 179
 Knot-work 100, 108, 110, 139, 151, 187
 Knox D'Arcy, William 125
 Krishna 14, 17, 54, 55, 123.
 Kurukshetra 123
 Lake Neuchâtel 32
 Lake Titicaca P2
 Lamech, Song of 64
 Lancelot 120, 121, f40, 124, 125
 Last Supper P17, 92, 118, 139, 140, 187
 Latinised-Greek 179
 La Tène f3, 30, 35, 37, 38, P24, 100, 141, 142, 177, 179
 Lazarus 92
 Le Fay, Morgan f40
 Leviticus 68
 Lichfield Gospels 112
 Liebfried, Renate 18
 Lindisfarne 100, 101, 102, 103, 105, 109, 112, 115, 179
 Lindisfarne Gospels P16 142, 174
 Lismore 53,
 Liu Sheng, Prince P21, 134, f44
 Longinus 80, f29
 Lord Pacal 14, 15, 22, 24, 42, 45, 54, 55 P12, f9, f12, f21, f22, P3, P6, 59, 60, 112, f38,
 124, 159, 161, 177, 182, A10
 Loulan, beauty of, f1a, P1
 Lucan 121, f40, f41
 Luke, Gospel of 88, 90
 Lucanus 49,
 Lunula 53, f23, f24
 Maccabaeus, Judas 67
 Maccabees 67
 Maddox-Brown, Ford 125
 Magdalene, Mary 84, 92
 Magi 48,
 Mahabarata 17
 Maimonides, Rabbi 75, 106, 123
 Mair, Professor Victor 1, P1
 Malachi 65, 68
 Mallory, Professor J.P. 1, P1
 Malory, Thomas 117, 119, 121, 130
 Manasses, Prayer of 67
 Manx 84
 Mariner II 9, 11
 Mark, Gospel of 88, 90
 Mary Magdalene, Acts of 68
 Massalia 29, 46, f3

Mathius 139, 178
 Matthew, Gospel of 88, 90
 Maya Transformer 15, 17, 177, fA10 P2–f3, P25, f64, f65
 Maze-like pattern, secrets of, f65, 161, 180
 Menstruation 49, F8
 Mercury [metal] f5, 15
 Mercury [planet] 134
 Merlin 119, 120, 121, 177, 180
 Mesh-mat panels 147, f48, 180
 Mesopotamia 59
 Micah 64, 65, 68
 Mil 2, 53
 Milky Way 58
 Millais, John Everett 125
 Miriam, Song of 64
 Missing stud, mystery of 153
 Mithraism 41
 Mithras 41,
 Mitterkirchen f3, 28,
 Monasteries 96
 Mont Guerin f15
 Mont Lassois f3 18, 28, f15, 29, 35
 Monte Alban 17, f16, 159
 Montmorot f15
 Mordred f40
 Morris, William 125
 Mosaic Mask of Palenque P24, 183
 Moses 61, 62, 73, 96
 Mummies I, f1a, P1
 Mural of Bonampak P3, P4, f12, 45, 54, 182
 Muratorian Fragments 92
 Nagold f15
 Nag Hamadi 68
 Names, mystery of 153
 Nahum 68
 Narmer, King 56
 Nazca P5
 Nebuchadnezzar, King 65
 Nefertiti 60
 Nehemiah 65, 68

233

BIBLIOGRAPHY

- Moon, Peter, *The Black Sun, Sky* (New York) 1997.
 Moore, Hunt, Nicolson and Cattermole, *The Atlas of the Solar System*, Mitchell Beazley, 1995.
 Morley, S. G., *An Introduction to the Study of Maya Hieroglyphs*, Dover, 1915.
 MacNeill, Eoin, *Celtic Ireland*, Dublin: Martin Lester Ltd, 1921.
 McLeish, Kenneth, *Myths and Legends of the World*, Blitz Editions, 1996.
 Musurillo, Herbert (ed.), *The Acts of the Christian Martyrs*, Oxford Clarendon Press, 1972.
 Osborn, Eric, *The Beginning of Christian Philosophy*, Cambridge University Press, 1981.
 Parker, Geoffrey, *The Times Atlas of World History*, HarperCollins, 1978.
 Pearson, R., *Climate and Evolution*, Academic Press, 1978.
 Peterson, Roland, *Everyone Is Right: A New Look at Comparative Religion and Its Relation to Science*, California: De Vorss & Co, 1986.
 Philip's *Atlas of the Celts*, George Philip Ltd, 2001.
 Pierpaoli, Walter, and William Regelson, with Carol Colman, *The Melatonin Miracle*, Simon & Schuster, 1995.
 Posnansky, Arthur, *Tihuanacu, the Cradle of American Man*, New York: J. J. Augustin, 1945.
 Powell, Neil, *The Book of Change: How to Understand the I Ching*, Orbis, 1979.
 Poynder, Michael, *Pie in the Sky*, Rider, 1992.
 Price, Glickstein, Horton and Bailey, *Principles of Psychology*, Holt Rinehart and Winston, 1982.
 Raftery, Barry (ed.) *Atlas of the Celts*, Philips, 2001.
 Reiche, Maria, *Nazca Peru, Mystery of the Desert*, Hans Shultz-Severin, 1968.
 Reinhard, Johan, *The Nazca Lines: A New Perspective on Their Origin and Meaning*, Editorial Los Pinos, 1985.
 Roys, Ralph R., *The Book of Chilam Balam of Chumayel*, University of Oklahoma Press, 1932.
 Rutherford, Ward, *Celtic Lore*, Thorsons, 1993.
 Ryan, M. (ed.) *Treasures of Ireland*, Royal Irish Academy, 1983.
 Schweitzer, Albert, *The Quest of the Historical Jesus*, trans. William Montgomery, New York: Macmillan, 1961.
 Sharkey, John, *Celtic Mysteries*, Thames and Hudson, 1975.
 Swami Shri Purohit, *The Geeta*, Faber & Faber, 1935.
 Sykes, Egerton, *Dictionary of Non-Classical Mythology*, J. M. Dent, 1952.
 Talbot Rice, David, *The Dark Ages*, Thames & Hudson, 1965.
 Thomson, W. A. R., *Black's Medical Dictionary*, A. & C. Black, 1984.
 Thorpe, Lewis (trans.) Geoffrey of Monmouth (c. 1136), *The Kings of Britain*, Penguin, 1973.

231

Némim 2
 Nevyim 64
 Newgrange 2
 New Testament 68, 89, 91, 92
 Normans 2
 Numbers 68
 Numerical matrix fA17
 Obadiah 64, 68
 Oestrogen 11
 Old Testament 67, 68, 69, 89, 92
 Olmec f16
 Olmec Head P10
 Omega 151
 Origen 91
 Orion 57, 134, 176
 Osiris 15, 57, 58, 60
 Owain f40, f41
 Oxford Genetic Atlas Project 2
 Pachomius 91
 Palenque 15, 22, 45,
 Palenque, Amazing Lid of P5,
 P12, f54, fA10
 Palenque, Mosaic Mask P6
 Palestine 68
 Palladius, Bishop 99
 Parable(s) 75
 Parry, Sir Hubert 71
 Pashcal 54
 Passover 115
 Patrick, St. f33 94, 99, 100
 Paul, St 88, 96
 Paul, St, Letters of, 88, 99
 Peacocks 176
 Penanular f43
 Pentateuch 69
 Perceval 117, 118, 121, f41
 Pepi II 58
 Peshitto 92
 Peter, Acts of 68
 Philip, Gospel of 68
 Philistines 2, f1a, 62, 65
 Picts 93, 104
 Pilate, Pontius 84
 Planisphere 24,
 Pliny 48,
 Pocket Gospels 99, 109,
 Popol Vuh 75
 Pre-Raphaelite(s) P18, 124, 125,
 126, 129
 Promised Land 62
 Progesterone 11
 Proverbs, Book of 62, 68
 Psalms 68, 98
 Ptah-Hotep 58
 Pyramid of Inscriptions 15, f12,
 110, f38,
 Qawrighul 5
 Quartz crystal 140, 163
 Quetzalcoat P6
 Quinn, Jimmy 141
 Ra 57, 58
 Raevemose 38, f19,
 Ramses I 61
 Reflóir 2
 Reformation 100
 Reiche, Maria 106
 Reinheim 35
 Revelation 14 P5, f12, 20, 42, 89,
 92, 135
 Ring brooch f43
 Rinnagan Crucifixion Plaque 80,
 81, 82, f29
 Round Table 120, 121, f41, 125,
 129, 140
 Rome f1b, f3,
 Roman, colonies 47
 Rosseti, Dante Gabriel 125
 Royal Irish Academy 141
 Ruth 68
 Sacred Geometry 220-224
 Salome 117
 Sambre 46
 Samuel, King 62, 63
 Samuel, the First Book of, 68
 Samuel, the Second Book of, 68
 Sanhedrin 69, 77
 Sanskrit 49, 54, 55
 Saul 62, 88

234

BIBLIOGRAPHY

- Von Hagen, W., *The Ancient Sun Kingdoms of the Americas*, Thames and Hudson, 1962.
 Wallace, P. F., and Ragnall Ó Floinn (eds.), *Treasures of the National Museum of Ireland*, Gill & Macmillan, 2002.
 Warner, R. (ed.), *Encyclopaedia of World Mythology*, BPC, 1970.
 Wegener, G. S., *6,000 Jahre und ein Buch*, Oncken Verlag Kassel, 1958.
 Welker, H. A., P. Semm, R. P. Willig, W. Wiltschko, L. Vollrath, 'Effects of an artificial magnetic field on serotonin-N-acetyltransferase activity and melatonin content of the rat pineal gland', *Exptl. Brain Res.* 50:426-531, 1983.
 White, J., *Pole Shift*, Virginia Beach: ARE Press, 1993.
 Willis, Roy (consultant), *Dictionary of World Myth*, Duncan Baird, 1995.
 Willis, Roy (ed.), *World Mythology—The Illustrated Guide*, Piatkus, 1993.
 Zaczek, Iain, *The Art of the Celts*, London: Parkgate Books, 1997.
 ———, *Chronicles of the Celts*, Collins & Brown, 1996.

232

Schiffenen f15
 Schwab, Friedrich 35,
 Scotta 2, 54
 Scotti 54,
 Script, mystery of, 153
 Scythia 2
 Sentenium 46
 Shaman(s) 48,
 Siege Perilous P17
 Siva 55, 121, 129
 Sinai, Mount 61
 Solar cross f2, 150
 Solar neutral sheet 32
 Solar wind 9, 47
 Solar wind, sectored structure of,
 9
 Solomon, King 62, 63, 64, 67
 Solomon, Song of, 68, 124
 Solon I
 Song of the Three Children 67
 Soul transmigration 211
 Springmount Bog 103
 Spiral, Celtic 80, 81, 187
 Star of David P2, 15, f9,
 Stephaton 80, f29
 Steppe f1a
 Strasbourg Cathedral 32
 Strabo 48
 Stokes, Margaret 151
 Stonehenge 2
 Summerians f1a, 56
 Synod of Whitby 100
 Subconical studs f62
 Sun shield (of Monte Alban) P1,
 14, 15, f9, f12, 42, 55
 Sunspot cycle 206
 Sunspots 24, 53,
 Susanna 67
 Swastika(s) 9, 11, f4, f7, 14, 187
 Swastika panels, secrets of 163,
 f60, 176, 179
 Swastikas, reverse(d) 11, 22, 24,
 f32a, f32b
 Sykes, Professor Brian 2
 Synod 91
 Taklamakan desert 1, 2, 53, P1, 56
 Taprobane 2
 Tara 2
 Tara Brooch 109, 130, 134, 135,
 136, f44 P20, P21, P22, 138, 139,
 140, 177, 178
 Tarim f1a, 5, P1
 Tatian 90
 Tatian's Gospels 92
 Tau cross 156, f52-54 180
 Telemon 46
 Ten Commandments 61, 64, 73
 Teutones 42,
 Thomas, Gospel of 68
 Three Worlds A18
 Thutmose 61
 Tiahuanaco 159, 161, P5
 Tiber 46,
 Tigris 56, 59
 Torah 61
 Torc 20, 36, 37, 38, f20
 Truth, Gospel of 68, 91
 Tuatha Dé 2
 Turkestan f1a, 5
 Tutankhamun 15, 17, 24, 27, 45,
 53, 54, 59, 60, 61, 124, 133, 177
 Tutankhamun, tomb fA13
 Uncial 103
 Uncial, half 103
 Úrümchi f1a, P1
 Uther Pendragon 119, 120, f40
 Van Allen belts 11
 Vedas 55
 Vercingetorix 47
 Velikovskiy, Immanuel 13,
 Venus P22, 60, 63, f27, 112, 133,
 134, f44
 Vesica Pisces P3, P9, 15, f9, 155
 Vetusta Ecclesia 92
 Vikings 103, 181
 Viracocha 15, 42, 54, 55, P3, P5,
 P10, P24, f9, 108, 124, 127, 140,
 f55, 161, 182, f65, f66, 186

235

Index

Note: Page numbers in **bold** refer to black-and-white illustrations. Numbers preceded by CP refer to the color plates.

Abraham, 54
 Abraham, Karl, 59
 Absalom, 60
 Acts of the Apostles, 85
 Adomnan, 97
 Agricola, Governor, 48
 Ahab, 62
 Aidan, St., 98
 Aidey, Ross, 11
 Akhenaten, 58, 59
 Alban, St., 89
 Alesia, 47
 Alpha, 149
 Alpine, 7
 Amazing lid of Palenque, 21, 42
 Amber, 26, 28, 36
 Amenophis III, 58
 Amos, 62, 66
 Anglo-Saxons, 2
 Apocrypha, 65
 Apollo, 39
 Apostles, twelve, 70, 85, 169, 172, 178
 Ardagh Chalice, CP16, CP19, CP20,
 CP23, 108, 136, 138, Ch.5
 Ardagh Hoard, 136, 139
 Argumenta, 102
 Arimathea, Joseph, 77, 92, 116, 119,
 127, 176, 178
 Arjuna, 18, 121
 Ark of the Covenant, 59
 Arles, Council of, 89
 Art Deco, 59
 Artemis, 39
 Arthur, King, 114-15, 118, **120**, 134,
 138, 153, 155, 165, 176, 178, 179
 Arthurian legend(s), CP17, CP20,
 114, 115, 117, 119, 122, 127, 128,
 134, 138, 176, 177, 179
 Aryans, 2
 Assyrians, 62
 Astrology, 82
 Athanasius, 90
 Athenaeus, 48
 Atlantis, 1
 Atum, 54
 Augustus, Caesar, 66
 Augustus, Emperor, 48
 Aztec(s), 49-50

233

Némlín 2
 Nevyim 64
 Newgrange 2
 New Testament 68, 89, 91, 92
 Normans 2
 Numbers 68
 Numerical matrix fA17
 Obadiah 64, 68
 Oestrogen 11
 Old Testament 67, 68, 69, 89, 92
 Olmec f16
 Olmec Head P10
 Omega 151
 Origen 91
 Orion 57, 134, 176
 Osiris 15, 57, 58, 60
 Owain f40, f41
 Oxford Genetic Atlas Project 2
 Pachomius 91
 Palenque 15, 22, 45.
 Palenque, Amazing Lid of P5, P12, f54, fA10
 Palenque, Mosaic Mask P6
 Palestine 68
 Palladius, Bishop 99
 Parable(s) 75
 Parry, Sir Hubert 71
 Pashcal 54
 Passover 115
 Patrick, St, f33 94, 99, 100
 Paul, St 88, 96
 Paul, St, Letters of, 88, 99
 Peacocks 176
 Penanular f43
 Pentateuch 69
 Perceval 117, 118, 121, f41
 Pepi II 58
 Peshitto 92
 Peter, Acts of 68
 Philip, Gospel of 68
 Philistines 2, f1a, 62, 65
 Picts 93, 104
 Pilate, Pontius 84
 Planisphere 24,
 Pliny 48,
 Pocket Gospels 99, 109,
 Popol Vuh 75
 Pre-Raphaelite(s) P18, 124, 125,
 126, 129
 Promised Land 62
 Progesterone 11
 Proverbs, Book of 62, 68
 Psalms 68, 98
 Ptah-Hotep 58
 Pyramid of Inscriptions 15, f12,
 110, f38,
 Qawrighul 5
 Quartz crystal 140, 163
 Quetzalcoatl P6
 Quinn, Jimmy 141
 Ra 57, 58
 Raevemose 38, f19,
 Ramses I 61
 Reflóir 2
 Reformation 100
 Reiche, Maria 106
 Reinheim 35
 Revelation 14 P5, f12, 20, 42, 89,
 92, 135
 Ring brooch f43
 Rinnagan Crucifixion Plaque 80,
 81, 82, f29
 Round Table 120, 121, f41, 125,
 129, 140
 Rome f1b, f3,
 Roman, colonies 47
 Rosseti, Dante Gabriel 125
 Royal Irish Academy 141
 Ruth 68
 Sacred Geometry 220-224
 Salome 117
 Sambre 46
 Samuel, King 62, 63
 Samuel, the First Book of, 68
 Samuel, the Second Book of, 68
 Sanhedrin 69, 77
 Sanskrit 49, 54, 55
 Saul 62, 88

Schiffenen f15
 Schwab, Friedrich 35,
 Scotta 2, 54
 Scotti 54,
 Script, mystery of, 153
 Scythia 2
 Sentenium 46
 Shaman(s) 48,
 Siege Perilous P17
 Siva 55, 121, 129
 Sinai, Mount 61
 Solar cross f2, 150
 Solar neutral sheet 32
 Solar wind 9, 47
 Solar wind, sectored structure of,
 9
 Solomon, King 62, 63, 64, 67
 Solomon, Song of, 68, 124
 Solon 1
 Song of the Three Children 67
 Soul transmigration 211
 Springmount Bog 103
 Spiral, Celtic 80, 81, 187
 Star of David P2, 15, f9,
 Stephaton 80, f29
 Steppe f1a
 Strasbourg Cathedral 32
 Strabo 48
 Stokes, Margaret 151
 Stonehenge 2
 Summerians f1a, 56
 Synod of Whitby 100
 Subconical studs f62
 Swastika panels, secrets of 163,
 f60, 176, 179
 Swastikas, reverse(d) 11, 22, 24,
 f32ai, f32bi
 Sykes, Professor Brian 2
 Synod 91
 Taklamakan desert 1, 2, 53, P1, 56
 Taprobane 2
 Tara 2
 Tara Brooch 109, 130, 134, 135,
 136, f44 P20, P21, P22, 138, 139,
 140, 177, 178
 Tarim f1a, 5, P1
 Tatian 90
 Tatian's Gospels 92
 Tau cross 156, f52-54 180
 Telemon 46
 Ten Commandments 61, 64, 73
 Teutones 42,
 Thomas, Gospel of 68
 Three Worlds A18
 Thutmose 61
 Tiahuanaco 159, 161, P5
 Tiber 46,
 Tigris 56, 59
 Torah 61
 Torc 20, 36, 37, 38, f20
 Truth, Gospel of 68, 91
 Tuatha Dé 2
 Turkestan f1a, 5
 Tutankhamun 15, 17, 24, 27, 45,
 53, 54, 59, 60, 61, 124, 133, 177
 Tutankhamun, tomb fA13
 Uncial 103
 Uncial, half 103
 Úrümchi f1a, P1
 Uther Pendragon 119, 120, f40
 Van Allen belts 11
 Vedas 55
 Vercingetorix 47
 Velikovskiy, Immanuel 13,
 Venus P22, 60, 63, f27, 112, 133,
 134, f44
 Vesica Pisces P3, P9, 15, f9, 155
 Vetusta Ecclesia 92
 Vikings 103, 181
 Viracocha 15, 42, 54, 55, P3, P5,
 P10, P24, f9, 108, 124, 127, 140,
 f55, 161, 182, f65, f66, 186

BIBLIOGRAPHY

Von Hagen, W., *The Ancient Sun Kingdoms of the Americas*, Thames and Hudson, 1962.
 Wallace, P. F., and Ragnhail Ó Floinn (eds.), *Treasures of the National Museum of Ireland*, Gill & Macmillan, 2002.
 Warner, R. (ed.), *Encyclopaedia of World Mythology*, BPC, 1970.
 Wegener, G. S., *6,000 Jahre und ein Buch*, Onjken Verlag Kassel, 1958.
 Welker, H. A., P. Semm, R. P. Willig, W. Wilschko, L. Vollrath, 'Effects of an artificial magnetic field on serotonin-N-acetyltransferase activity and melatonin content of the rat pineal gland', *Expil. Brain Res.* 50:426-531, 1983.
 White, J., *Pole Shift*, Virginia Beach: ARE Press, 1993.
 Willis, Roy (consultant), *Dictionary of World Myth*, Duncan Baird, 1995.
 Willis, Roy (ed.), *World Mythology—The Illustrated Guide*, Piatkus, 1993.
 Zaczek, Iain, *The Art of the Celts*, London: Parkgate Books, 1997.
 ———, *Chronicles of the Celts*, Collins & Brown, 1996.

Index

Note: Page numbers in bold refer to black-and-white illustrations. Numbers preceded by CP refer to the color plates.

Abraham, 54
 Abraham, Karl, 59
 Absalom, 60
 Acts of the Apostles, 85
 Adomnan, 97
 Agricola, Governor, 48
 Ahab, 62
 Aidan, St., 98
 Aidey, Rosa, 11
 Akhenaten, 58, 59
 Alban, St., 89
 Alesia, 47
 Alpha, 149
 Alpine, 7
 Amazing lid of Palenque, 21, 42
 Amber, 26, 28, 36
 Amenophis III, 58
 Amos, 62, 66
 Anglo-Saxons, 2
 Apocrypha, 65
 Apollo, 39
 Apostles, twelve, 70, 85, 169, 172, 178
 Ardagh Chalice, CP16, CP19, CP20,
 CP23, 108, 136, 138, Ch.5
 Ardagh Hoard, 136, 139
 Argumenta, 102
 Arimatea, Joseph, 77, 92, 116, 119,
 127, 176, 178
 Arjuna, 18, 121
 Ark of the Covenant, 59
 Arles, Council of, 89
 Art Deco, 59
 Artemis, 39
 Arthur, King, 114-15, 118, **120, 134,**
 138, 153, 155, 165, 176, 178, 179
 Arthurian legend(s), CP17, CP20,
 114, 115, 117, 119, 122, 127, 128,
 134, 138, 176, 177, 179
 Aryans, 2
 Assyrians, 62
 Astrology, 82
 Athanasius, 90
 Athenaeus, 48
 Atlantis, 1
 Atum, 54
 Augustus, Caesar, 66
 Augustus, Emperor, 48
 Artec(s), 49-50

SHOOK THE FREEMASONS
 Primary discovery Express

... detective, Maurice Cornille, the
 examines the life, times and tomb of
 a key from the pyramids of Mexico
 which have kept safe the secrets of the
 more than 3,000 years.
 remarkable as they are sensation
 should never have been robbed, the
 way only part of the truth
 it have been Tutankhamun's father
 of the Maya, Tutankhamun encoded
 into his treasures, as a message to
 the generation
 in the Bible, the hidden treasures of
 of Lord Pascal all tell the same story
 known and thrives today, concealed
 by the Church and the higher
 . For the first time ever, Maurice
 for the secrecy, reasons which
 the future of us all.
 books I have ever read in my life
 the author of *The Outsider*

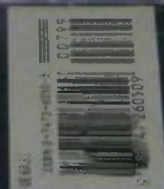

Viracocha Pachacamac 17, f11, 22,
25, f21, 45, P5, P24, 182, f65, f66
Viracocha Pachacamac, coffin
fA15
Viracocha Pachacamac, tomb
fA14
Viracocha transformer 188, fA5-
fA9
Viracocha pattern f57, f58
Viracocha vase P3, 159, f56, 177
Vishnu 55
Vita Columbae 99
Vortigern 93
Vulgate 92, 104, 105
Waterhouse, John W. P18, 125,
126,
Well, 64
Willibroard, St 112
Wurzburg f15
Xipe Totec P3, P4, 32
Xiuhtechutli P10
Ybys Môn 47.
Yellow rim and nails 165, f61
Ying and Yang 82
Zaghunluq f1a, P1
Zechariah 65, 68
Zedekiah 64
Zephaniah 64
Zeus 41, 67
Zeus-Jupiter 13.
Zion, Mount 62, 65

INDEX

Babylonians, 62, 63
Baden-Wuerttemberg, 18
Bain, George, 99, 106, 107, 108-9
Baptist, John the, 70, 115-16
Basil, 89
Bas relief, 15, 17
Basse Yutz, 7, 36, 37, 38, 149
Basse Yutz flagons, CP14, 109, 137,
176
Bat god, CP8, 4, 24, 32, 33, 132
Bede, 91
Bedivere, 119, 120
Bel and the Dragon, 65
Benedict, 89
Bethlehem, 66
Bhagavad Gita, 18, 80, 121
Biel, Joel, 18
Birth of Venus, 14-15, 16
Blair, Edmund, 123
Blake, William, 67
Bonampak, 35
Boniface, St., 98
Boudicca, 48
Bowl and Girdle, 136, 148, 149
Bowl girdle panels, 150
Bowl girdle, stud mountings,
151
Brahma, n.226
Brahmans, 54, 55
Breisach, 30
Breves Causae, 101
Bridle, 26, 27
Bronze-Age, 29
Brotherhood, 122
Burdiba, 14, 15
Burostomas, Etowah, CP17, 121, 123,
126
Butha, 139
Byzantine, 91, 106, 129, 143, 178
Byzantium, 91

Caesar, Julius, 47, 48
Caicher, 3
Calderon, William Frank, 123
Camp de Chassey, 29, 30, 31
Canaan, 2, 54, 57, 59, 60, 63
Canon Tables, 102, 103
Carpet Pages, 100, 103
Carter, Howard, 57, 58
Carving, secrets of, 154, 155
Caryatid, 23, 24
Caspian Sea, 3
Cassivellaunus, 47
Cathach, 101
Cathach of St. Columba, 103
Caucasians, 1
Celestine, Pope, 97
Cernunnos, CP22, 39, 41, 42, 44, 45,
131
Chakra, 81
Chalice engraving, 157
Champlevé, 37
Chatillon-sur-Glane, 30
Châtillon-sur-Seine, 19
Checkers, 61
Cherchen, 5
Ch'in Shi Huangdi, 18, 23, 29, 46, 112,
122, 132
Chi Zeus, 42
Chrétien de Troyes, 114, 115, 116, 119
Chronicles, the First Book of, 65
Chronicles, the Second Book of, 66
Cinnabar, 16
Claudius, Emperor, 48
Clusonné, 227
Clusium, 46
Codex Carolinus, 96
Codex Usserianus, 101
Codex Victor, 96
Cohigny, 48, 143
Coln, Cille, 99

INDEX

Columba, St., 97, 98, 103
Compasses, freemason, CP7, CP8
Confucius, 11
Conjoined dragons, 154, 155, 156
Constantine the Great, 89, 91
Continuous-line drawing, 99, 105,
106, 107, 137
Copicat monks, 172, 174
Cornwall, 67
Cranfield University, 14
Crystal, foot cone, secrets of, 162
Cyrus, 63
Danann, 2
Daniel, 64, 65, 66
David, King, 60, 61, 63
De Grance, Leon, 118, 120
De Leon, Cieza, 188
Delphi, 5, 7, 39, 47
Dendera, 56
Derrynaflan Hoard, 169, 170, 171-72,
179
Deuteronomy, 63, 65
Dicksee, Leighton Frank, 123
Diodorus, 48
Divine Reconciliation, theory of, 34,
40, 41, 71, 185
DNA, 2, 22, 50-51
Domitian, Emperor, 48, 87
Donn, 3
Dragon-angels, CP19, 138, 154
Dragonhead, CP21, CP22, 131, 132,
134, 137
Dragons, secrets of, 154, 155
Draughts, 61
Dresden Codex, 14
Druidic, 4, 48, 141
Druidism, 48
Druids, 48, 50, 51
Dunraven, Lord, 141, 147, 149, 152
Durrow, 97, 100, 102, 103, 108
Éber, n.225
Ecclesiastes, CP18, 61, 66, 126, 166
Echternach Gospels, 111
Ector, Sir, 117
Ecumenical Council, 89-90
Elijah, 62
Elisha, 62
Emly, n.222
Enda, St., 97
Ephraim, 88
Episcopal, 97
Epistles, 86-87, 88
Erémón, 3, n.225
Esther, 64, 66
Ethelbert, King, 97
Ethewald, 100, 101
Eucharist, 116
Eugippius, 111
Euphrates, 54, 57
Excalibur, CP19, CP20, 117, 118, 119,
120, 121, 122, 128, 186
Existence, General theory of, 34, 40,
41, 71
Exodus, 60, 62, 63, 64, 65
Ezekiel, 63, 66
Fair Rosamund, CP18, 123, 125
Feathered snake, 131, 137, 181,
215-18
Fertility, god of, 4
Finnian, St., 99
Fisher King, 115, 116
Flanagan, Paddy, 136
Foot-cone, 143, 144, 148, 179
Freud, Sigmund, 59
Galahad, Sir, 91, 119, 120, 178
Gateway of the Sun, CP2, 8, 15, 17

INDEX

Gawain, 120
 Genesis, 63, 65
 Geoffrey of Monmouth, 114, 117
 Gerald of Wales, 98
 Glastonbury, 90, 129
 Glauberg, 7, 31, 32
 Gleninsheen Gorget, 52
 God, first picture of, CP24
 Gorlois, 117
 Gospels, 66, 70, 72, 85, 87, 88, 100, 102, 103, 105
 Grammar, mystery of, 153
 Gregory I, Pope, 97
 Gregory II, Pope, 96
 Guinevere, 118, 119, 120, 122, 128
 Gundestrup cauldron, 39, 40, 41, 43, 44, 131
 Habakkuk, 62, 66
 Haggai, 63, 66
 Hallstatt, 7, 8, 11, 14, 18, 19, 29, 31, 33, 35-36, 38, 83, 137, 181
 Handle escutcheon plates, 168
 Han tomb, CP11
 Hathor, 10
 Hebrew(s), 2, 54, 59, 62, 64, 67, 87, 88
 Heidelberg, 33
 Hengist, 91
 Herod, King, 67
 Heroditus, 115
 Heshbon, 62
 Heuneburg, 30
 Hill-fort, 30, 30, 31, 36, 46, 47
 Hochdorf, 7, 18, 20, 28-29
 Hochdorf, King of, 24, 27, 28, 51, 179
 Hohenasperg, 30
 Holman Hunt, William, 123
 Holy Grail, CP17, CP19, CP23, 90-91, 115, 117, 119, 123, 127, 138, Ch. 5
 Horsa, 91
 Hosea, 62, 66
 Hughes, Arthur, 123
 Hyksos, 57
 Igraine, Queen, 117, 120
 Illuminated manuscripts, 102, 108, 173, 175, 176, 177, 179
 IMP I, 12
 Indo-Aryan, n226
 Information, encoding of, n203
 Inisfallen, n224
 Initial Pages, 100, 103
 Insular majuscule, 101, 102, 103, 140, 173
 Iona, 97, 98, 100, 101
 Ír, 3, n225
 Irenaeus, 88
 Irish World Chronicles, 2
 Isaiah, 63, 66
 Isle of Man, 84
 Israel, 60, 62
 Israelites, CP15, 59-60
 Iterative Spiritual Development, theory of, 34, 40, 41, 71, 97, 111, 212
 Ivinghoe Beacon, 30
 Jade suit, 132, CP21
 Jehova, 59, 87
 Jehu, 62
 Jeremiah, 63, 66
 Jeremiah, The Lamentations of, 66
 Jerome, 90, 102, 103
 Job, 66
 Joel, 66
 John, Gospel of, 88
 Jonah, 62, 66
 Joseph, 66-67
 Joshua, 60, 65
 Judah, 62

Judaism, 15, 16, 17
 Judges, 60, 65
 Kalasasaya, 190, 192, 198, 200
 Kanes, 57
 Karma, 96
 Karmic, 49
 Katzenbuckel, 36
 Kay, 120
 Kells, 100, 101-2, 103, 109, 113, 140, 174
 King Arthur, CP17
 Kings the First Book of, 66
 Kings, the Second Book of, 66
 Kleinaspergl, 36
 Knights of the Round Table, 90-91, 117, 120, 157, 178
 Knot-work, 98, 106, 109, 137, 150, 186
 Knox D'Arcy, William, 123
 Krishna, 15, 18, 121, n226
 Kurukshetra, 121
 Lake Neuchâtel, 35
 Lake Titicaca, CP2
 Lamech, Song of, 62
 Lancelot, 118, 122, 120, 127
 Last Supper, CP17, 90, 116, 138, 186
 La Tène, 7, 31, 35-38, P24, 98, 139, 140, 176, 178
 Latinised Greek, 177
 Lazarus, 90
 Le Fay, Morgan, 119, 120
 Leviticus, 63, 65
 Lichfield Gospels, 111
 Liebfried, Renate, 18
 Lindisfarne Gospels, CP16 142, 174
 Lindisfarne, 98, 100, 101, 103, 108, 111, 113, 176
 Liu Sheng, Prince, CP21, 132
 Longinus, 78, 79

Loulan, beauty of, CP1, 4, 5
 Lucan, 119, 120
 Lucanus, 50
 Luke, Gospel of, 70, 71, 72, 86, 88
 Lunula, 51, 52, 53
 Maccabaeus, Judas, 65
 Maccabees, 65
 Maddox-Brown, Ford, 123
 Magdalene, Mary, 84, 90
 Magi, 49
 Mahabarata, 18
 Maimonides, Rabbi 72, 104, 119
 Mair, Professor Victor, CP1, 1
 Malachi, 63, 65
 Mallory, Professor J.P., CP1, 1
 Malory, Thomas, 114, 117, 118, 119, 120, 121, 128
 Manasses, Prayer of, 65
 Manx, 84
 Mariner II, 11, 12
 Mark, Gospel of, 86, 88
 Mary Magdalene, Gospel of, 66
 Massalia, 7, 29, 47
 Mathius, 137, 177
 Matthew, Gospel of, 84, 86, 88
 Mayan Transformer, CP2-13, CP25, 15, 16, 20, 176, 174, 183
 Maze-like pattern, secrets of, 8, 158, 159, 160, 163, 164, 165, 180, 183
 Menstruation, 12, 49, 83
 Mercury [metal], 9, 16
 Mercury [planet], 132, 133
 Merlin, 117, 118, 119, 122, 176, 179
 Mesh-mat panels, 144, 146, 178, 179
 Mesopotamia, 55, 57
 Micah, 62-63, 66
 Mfl, 3, n225
 Milky Way, 56
 Millais, John Everett, 123

- Judaism, 15, 16, 17
 Judges, 60, 65
- Kalasasaya, 190, 192, 198, 200
 Kanes, 57
 Karma, 96
 Karmic, 49
 Katzenbuckel, 36
 Kay, 120
 Kells, 100, 101-2, 103, 109, 113, 140,
 174
 King Arthur, CP17
 Kings the First Book of, 66
 Kings, the Second Book of, 66
 Kleinaspergl, 36
 Knights of the Round Table, 90-91,
 117, 120, 157, 178
 Knot-work, 98, 106, 109, 137, 150, 186
 Knox D'Arcy, William, 123
 Krishna, 15, 18, 121, n226
 Kurukshetra, 121
 Lake Neuchâtel, 35
 Lake Titicaca, CP2
 Lamech, Song of, 62
 Lancelot, 118, 122, 120, 127
 Last Supper, CP17, 90, 116, 138, 186
- La Tène, 7, 31, 35-38, P24, 98, 139, 140,
 176, 178
 Latinised Greek, 177
 Lazarus, 90
 Le Fay, Morgan, 119, 120
 Leviticus, 63, 65
 Lichfield Gospels, 111
 Liebfried, Renate, 18
 Lindisfarne Gospels, CP16 142, 174
 Lindisfarne, 98, 100, 101, 103, 108,
 111, 113, 176
 Liu Sheng, Prince, CP21, 132
 Longinus, 78, 79
- Loulan, beauty of, CP1, 4, 5
 Lucan, 119, 120
 Lucanus, 50
 Luke, Gospel of, 70, 71, 72, 86, 88
 Lunula, 51, 52, 53
- Maccabaeus, Judas, 65
 Maccabees, 65
 Maddox-Brown, Ford, 123
 Magdalene, Mary, 84, 90
 Magi, 49
 Mahabarata, 18
 Maimonides, Rabbi 72, 104, 119
 Mair, Professor Victor, CP1, 1
 Malachi, 63, 65
 Mallory, Professor J.P., CP1, 1
 Malory, Thomas, 114, 117, 118, 119,
 120, 121, 128
 Manasses, Prayer of, 65
 Manx, 84
 Mariner II, 11, 12
 Mark, Gospel of, 86, 88
 Mary Magdalene, Gospel of, 66
 Massalia, 7, 29, 47
 Mathius, 137, 177
 Matthew, Gospel of, 84, 86, 88
 Mayan Transformer, CP2-13, CP25,
 15, 16, 20, 176, 174, 183
 Maze-like pattern, secrets of, 8, 158,
 159, 160, 163, 164, 165, 180, 183
 Menstruation, 12, 49, 83
 Mercury [metal], 9, 16
 Mercury [planet], 132, 133
 Merlin, 117, 118, 119, 122, 176, 179
 Mesh-mat panels, 144, 146, 178, 179
 Mesopotamia, 55, 57
 Micah, 62-63, 66
 Mîl, 3, n225
 Milky Way, 56
 Millais, John Everett, 123

INDEX

- Gawain, 120
 Genesis, 63, 65
 Geoffrey of Monmouth, 114, 117
 Gerald of Wales, 98
 Glastonbury, 90, 129
 Glauberg, 7, 31, 32
 Gleninsheen Gorget, 52
 God, first picture of, CP24
 Gorlois, 117
 Gospels, 66, 70, 72, 85, 87, 88, 100, 102, 103, 105
 Grammar, mystery of, 153
 Gregory I, Pope, 97
 Gregory II, Pope, 96
 Guinevere, 118, 119, 120, 122, 128
 Gundestrup cauldron, 39, 40 41, 43, 44, 131
 Habakkuk, 62, 66
 Haggai, 63, 66
 Hallstatt, 7, 8, 11, 14, 18, 19, 29, 31, 33, 35-36, 38, 83, 137, 181
 Handle escutcheon plates, 168
 Han tomb, CP11
 Hathor, 10
 Hebrew(s), 2, 54, 59, 62, 64, 67, 87, 88
 Heidelberg, 33
 Hengist, 91
 Herod, King, 67
 Heroditus, 115
 Heshbon, 62
 Heuneburg, 30
 Hill-fort, 30, 30, 31, 36, 46, 47
 Hochdorf, 7, 18, 20, 28-29
 Hochdorf, King of, 24, 27, 28, 51, 179
 Hohenasperg, 30
 Holman Hunt, William, 123
 Holy Grail, CP17, CP19, CP23, 90-91, 115, 117, 119, 123, 127, 138, Ch. 5
 Horsa, 91
 Hosea, 62, 66
 Hughes, Arthur, 123
 Hyksos, 57
 Igraine, Queen, 117, 120
 Illuminated manuscripts, 102, 108, 173, 175, 176, 177, 179
 IMP I, 12
 Indo-Aryan, n226
 Information, encoding of, n203
 Inisfallen, n224
 Initial Pages, 100, 103
 Insular majuscule, 101, 102, 103, 140, 173
 Iona, 97, 98, 100, 101
 Ír, 3, n225
 Irenaeus, 88
 Irish World Chronicles, 2
 Isaiah, 63, 66
 Isle of Man, 84
 Israel, 60, 62
 Israelites, CP15, 59-60
 Iterative Spiritual Development, theory of, 34, 40, 41, 71, 97, 111, 212
 Ivinghoe Beacon, 30
 Jade suit, 132, CP21
 Jehova, 59, 87
 Jehu, 62
 Jeremiah, 63, 66
 Jeremiah, The Lamentations of, 66
 Jerome, 90, 102, 103
 Job, 66
 Joel, 66
 John, Gospel of, 88
 Jonah, 62, 66
 Joseph, 66-67
 Joshua, 60, 65
 Judah, 62

- Judaism
 Judges
 Kalasas
 Kanes, J
 Karma,
 Karmic,
 Katzenb
 Kay, 120
 Kells, 100
 174
 King Art
 Kings the
 Kings, the
 Kleinaspe
 Knights of
 117, 12
 Knot-work
 Knox D'Ar
 Krishna, 15
 Kurukshetr
 Lake Neuch
 Lake Titicac
 Lamech, Son
 Lancelot, 118
 Last Supper,
 La Tène, 7, 31
 176, 178
 Latinised Gre
 Lazarus, 90
 Le Fay, Morga
 Leviticus, 63, 6
 Lichfield Gosp
 Liebfried, Rena
 Lindisfarne Gos
 Lindisfarne, 98,
 111, 113, 176
 Liu Sheng, Princ
 Longinus, 78, 79

SONS
 ell, the
 footsteps
 mb of
 exico,
 of the
 mal
 the
 e
 ter
 oded
 ge to
 s of
 ory
 led
 er

- Gawain, 120
 Genesis, 63, 65
 Geoffrey of Monmouth, 114, 117
 Gerald of Wales, 98
 Glastonbury, 90, 129
 Glauberg, 7, 31, 32
 Gleninsheen Gorget, 52
 God, first picture of, CP24
 Gorlois, 117
 Gospels, 66, 70, 72, 85, 87, 88, 100, 102, 103, 105
 Grammar, mystery of, 153
 Gregory I, Pope, 97
 Gregory II, Pope, 96
 Guinevere, 118, 119, 120, 122, 128
 Gundestrup cauldron, 39, 40 41, 43, 44, 131
 Habakkuk, 62, 66
 Haggai, 63, 66
 Hallstatt, 7, 8, 11, 14, 18, 19, 29, 31, 33, 35-36, 38, 83, 137, 181
 Handle escutcheon plates, 168
 Han tomb, CP11
 Hathor, 10
 Hebrew(s), 2, 54, 59, 62, 64, 67, 87, 88
 Heidelberg, 33
 Hengist, 91
 Herod, King, 67
 Heroditus, 115
 Heshbon, 62
 Heuneburg, 30
 Hill-fort, 30, 30, 31, 36, 46, 47
 Hochdorf, 7, 18, 20, 28-29
 Hochdorf, King of, 24, 27, 28, 51, 179
 Hohensperg, 30
 Holman Hunt, William, 123
 Holy Grail, CP17, CP19, CP23, 90-91, 115, 117, 119, 123, 127, 138, Ch. 5
 Horsa, 91
 Hosea, 62, 66
 Hughes, Arthur, 123
 Hyksos, 57
 Igraine, Queen, 117, 120
 Illuminated manuscripts, 102, 108, 173, 175, 176, 177, 179
 IMP I, 12
 Indo-Aryan, n226
 Information, encoding of, n203
 Inisfallen, n224
 Initial Pages, 100, 103
 Insular majuscule, 101, 102, 103, 140, 173
 Iona, 97, 98, 100, 101
 Ír, 3, n225
 Irenaeus, 88
 Irish World Chronicles, 2
 Isaiah, 63, 66
 Isle of Man, 84
 Israel, 60, 62
 Israelites, CP15, 59-60
 Iterative Spiritual Development, theory of, 34, 40, 41, 71, 97, 111, 212
 Ivinghoe Beacon, 30
 Judaism, 15, 16, 17
 Judges, 60, 65
 Kalasasaya, 190, 192, 198, 200
 Kanes, 57
 Karma, 96
 Karmic, 49
 Katzenbuckel, 36
 Kay, 120
 Kells, 100, 101-2, 103, 109, 113, 140, 174
 King Arthur, CP17
 Kings the First Book of, 66
 Kings, the Second Book of, 66
 Kleinaspergl, 36
 Knights of the Round Table, 90-91, 117, 120, 157, 178
 Knot-work, 98, 106, 109, 137, 150, 186
 Knox D'Arcy, William, 123
 Krishna, 15, 18, 121, n226
 Kurukshetra, 121
 Lake Neuchâtel, 35
 Lake Titicaca, CP2
 Lamech, Song of, 62
 Lancelot, 118, 122, 120, 127
 Last Supper, CP17, 90, 116, 138, 186
 La Tène, 7, 31, 35-38, P24, 98, 139, 140, 176, 178
 Latinised Greek, 177
 Lazarus, 90
 Le Fay Morgan, 119, 120
 Leviticus, 63, 65
 Liebfeld Gospels, 111
 Liebfried, Renate, 18
 Lindisfarne Gospels, CP16 142, 174
 Lindisfarne, 98, 100, 101, 103, 108, 111, 113, 176
 Liu Sheng, Prince, CP21, 132
 Longinus, 78, 79
 Loulan, beauty of, CP1, 4, 5
 Lucan, 119, 120
 Lucanus, 50
 Luke, Gospel of, 70, 71, 72, 86, 88
 Lunula, 51, 52, 53
 Maccabaeus, Judas, 65
 Maccabees, 65
 Maddox-Brown, Ford, 123
 Magdalene, Mary, 84, 90
 Magi, 49
 Mahabarata, 18
 Maimonides, Rabbi 72, 104, 119
 Mair, Professor Victor, CP1, 1
 Malachi, 63, 65
 Mallory, Professor J.P., CP1, 1
 Malory, Thomas, 114, 117, 118, 119, 120, 121, 128
 Manasses, Prayer of, 65
 Manx, 84
 Mariner II, 11, 12
 Mark, Gospel of, 86, 88
 Mary Magdalene, Gospel of, 66
 Massalia, 7, 29, 47
 Mathius, 137, 177
 Matthew, Gospel of, 84, 86, 88
 Mayan Transformer, CP2-13, CP25, 15, 16, 20, 176, 174, 183
 Maze-like pattern, secrets of, 8, 158, 159, 160, 163, 164, 165, 180, 183
 Menstruation, 12, 49, 83
 Mercury [metal], 9, 16
 Mercury [planet], 132, 133
 Merlin, 117, 118, 119, 122, 176, 179
 Mesh-mat panels, 144, 146, 178, 179
 Mesopotamia, 55, 57
 Micah, 62-63, 66
 Mil, 3, n225
 Milky Way, 56
 Millais, John Everett, 123

INDEX

Miriam, Song of, 62
 Missing stud, mystery of, 150
 Mithraism, 42
 Mithras, 42
 Mitterkirchen, 7, 28
 Monasteries, 92
 Mont Guerin, 30
 Mont Lassois, 19, 28, 29, 30
 Monte Alban, 14, 32, 158, 159
 Montmorot, 30
 Mordred, 119, 120
 Morris, William, 123
 Mosaic Mask of Palenque, CP24, 183
 Moses, 59-60, 63, 64, 67, 71, 94
 Mummies, CP1, 1, 5
 Mural of Bonampak, CP3, CP4, 35, 43, 46, 181
 Muratorian Fragments, 88
 Nag Hamadi, 66
 Nagold, 30
 Nahum, 66
 Names, mystery of, 153
 Narmer, King, 54
 Nazca, CP5
 Nebuchadnezzar, King, 63
 Nefertiti, 58
 Nehemiah, 63, 66
 Némim, 3
 Nevyim, 62
 Newgrange, 2
 New Testament, 66, 70, 75, 87-88, 89-90
 Normans, 2
 Numbers, 63, 65
 Numerical matrix, 208
 Obadiah, 62, 66
 Oestrogen, 12, 13, 82-83
 Old Testament, 54, 64, 65, 67, 75, 87, 90

Olmec Head, CP10
 Olmec, 32
 Omega, 151
 Origen, 89
 Orion, 55, 134, 175
 Osiris, 15, 55, 56, 58
 Owain, 120
 Oxford Genetic Atlas Project, 2
 Pacal, Lord, CP3, CP6, CP12, 15, 17, 18, 23, 24, 29, 35, 42, 43, 44, 45, 46, 57, 58, 72, 74, 109, 110, 111, 122, 154, 160, 176, 204, 208, 218
 Pachomius, 89
 Palenque, 16, 18, 20, 42
 Palenque, Amazing Lid of, CP5, CP12, 156, 204
 Palenque, Mosaic Mask, CP6
 Palestine, 66
 Palladius, Bishop, 97
 Parable(s), 72-73
 Parry, Sir Hubert, 69
 Passover, *n.* 227-228
 Patriarchs, 62
 Patrick, St., 92, 97, 98
 Paul, St., 86, 88, 96
 Paul, St., Letters of, 86, 99
 Peacocks, 175
 Penanular, 129
 Pentateuch, 64, 67
 Pepi II, 56
 Perceval, 115, 116, 119, 120
 Peshitto, 90
 Peter, Acts of, 66
 Philip, Gospel of, 66
 Philistines, 1, 5, 60, 63
 Picts, 91
 Pilate, Pontius, 84
 Planisphere, 53
 Pliny, 48

Pocket Gospels, 97, 108
 Popol Vuh, 74
 Pre-Raphaelite(s), CP18, 122, 123, 124, 127
 Progesterone, 12, 13
 Promised Land, 60
 Proverbs, Book of, 60-61, 66
 Psalms, 66, 67, 98
 Ptah-Hotep, 56
 Pyramid of Inscriptions, 16, 22, 110
 Qawrighul, 4
 Quartz crystal, 137, 147, 160
 Quetzalcoatl, CP6
 Quinn, Jimmy, 139
 Ra, 55, 56
 Raevemose 39, 40
 Rameses I, 59
 Refloir, 3
 Reformation, 98
 Reiche, Maria, 104
 Reinheim, 36
 Revelation, CP5, 15, 22, 21, 44, 58, 87, 89, 133
 Ring brooch, 129
 Rinnagan Crucifixion Plaque, 78, 79, 80, 81
 Roman, colonies, 48
 Rome, 5, 7
 Rosetti, Dante Gabriel, 123
 Round Table, 118, 119, 120, 123, 127, 138
 Royal Irish Academy, 139
 Ruth, 65
 Sacred Geometry, 219-23
 Salome, 115
 Sambre, 47
 Samuel, King, 61

Samuel, the First Book of, 65
 Samuel, the Second Book of, 65
 Sanhedrin, 67, 74
 Sanskrit, 50
 Saul, 60, 86
 Schiffenen, 30
 Schwab, Friedrich, 35
 Scotta, 3
 Scotti, *n*225
 Script, mystery of, 152
 Scythia, 3
 Sentenium, 46-47
 Shaman(s), 49
 Siege Perilous, CP17
 Sinai, Mount, 59
 Siva, *n*226
 Solar cross, 6, 4, 51, 77, 148, 149, 150
 Solar neutral sheet, 35
 Solar wind, 10, 12, 51
 Solar wind, sectorized structure of, 10, 52
 Solomon, King, 60, 61, 62, 63, 65
 Solomon, Song of, 66, 122
 Solon, 1
 Song of the Three Children, 66
 Soul transmigration, 210, 211
 Spiral, Celtic, 80, 186
 Springmount Bog, 101
 Star of David, CP2, 15, 17
 Stephaton, 78, 79
 Steppe, 5
 Stokes, Margaret, 152
 Stonehenge, 2
 Strabo, 48
 Strasbourg Cathedral, 35
 Subconical studs, 169
 Sumerians, 5, 54, 55
 Sun shield (of Monte Alban), CP1, 14, 15, 16, 17, 21, 44, 135, 158, 159
 Sunspot cycle, 205

In 1989, while working at Cranfield University, engineer and scientist Maurice Cotterell found a way of calculating the duration of long-term magnetic reversals on the Sun. Using this knowledge he was able to break the codes of ancient sun worshipping civilizations—first the Mayas of Mexico, those of Tutankhamun of Egypt, and the Viracochas of South America, before cracking the codes of the Terracotta Warriors of China.

His own unique decoding process reveals amazing pictures from archaeological artefacts that explain the spiritual mysteries of life; why we are born, why we die and why this has to be.

His work, best described as *adventure fact*, brings together modern science, spirituality and ancient wisdom to unlock the secrets of the past, the present and the future.

In 1992 he was awarded the 'Voluntariado Cultural' medal, for his contributions to Mexican culture.

What they said about his books;

'Excellent work'... Sergio Arroyo Garcia,
 Director INAH (Mexico Inst. of Archaeology)

'Enough evidence to make even the most sceptical take note'... The Daily Mail

'An amazing discovery'... The Daily Express

'One of the most amazing books I have ever read'... Colin Wilson, Bestselling Author

Jacket photographs:
 front; Celtic chalice, rear; Tara brooch
 [obverse] © National Museum of Ireland

Cover by Maurice Cotterell

ISBN 0 9513195 9 0

INDEX

In 1989, while working at Cranfield University, engineer and scientist Maurice Cotterell found a way of calculating the duration of long-term magnetic reversals on the Sun. Using this knowledge he was able to break the codes of ancient sun worshipping civilizations—first the Mayas of Mexico, those of Tutankhamun of Egypt, and the Viracochas of South America, before cracking the codes of the Terracotta Warriors of China.

His own unique decoding process reveals amazing pictures from archaeological artefacts that explain the spiritual mysteries of life: why we are born, why we die and why this has to be.

His work, best described as *adventure fact*, brings together modern science, spirituality and ancient wisdom to unlock the secrets of the past, the present and the future.

In 1991 he was awarded the 'Voluntariado' medal for his contributions to archaeology.

What do you say about his books;

'Excellent work'... Sergio Arroyo Garcia, Director INAH (Mexico Inst. of Archaeology)

'Enough evidence to make even the most sceptical take note'... *The Daily Mail*

'An amazing discovery'... *The Daily Express*

'One of the most amazing books I have ever read'... Colin Wilson, Bestselling Author

Jacket photographs:

front; Celtic chalice, rear; Tara brooch [obverse] © National Museum of Ireland

Cover by Maurice Cotterell

ISBN 0 9513195 9 0

INDEX

Sunspots, 23, 51, 52
 Susanna, 65
 Swastika panels, secrets of, 163, 164, 165, 178
 Swastika(s) 11, 12, 14, 186
 Swastikas, reverse(d), 8, 22, 25, 83
 Sykes, Professor Brian, 2
 Synod, 89
 Synod of Whitby, 98
 Taklamakan desert, CP11, 51, 54, 56
 Taprobane, 3
 Tara, 2
 Tara Brooch, CP20, CP21, CP22, 108, 128, 130, 132, 134, 135, 138, 178, 179
 Tarim, CP1, 4, 5
 Tatian, 88
 Tatian's Gospels, 88
 Tau cross, 154, 155, 156, 157, 178
 Telemon, 47
 Ten Commandments, 59, 60, 62, 71
 Teutons, 42
 Thomas, Gospel of, 66
 Three Worlds, 211
 Thutmose, 58
 Tiahuanaco, CP5, 158, 159, 169
 Tiber, 46
 Tigris, 54, 55, 57
 Torah, 59
 Torc 19, 36, 37, 39, 41
 Truth, Gospel of, 66, 88
 Tuatha Dé, 2
 Turkestan, 4, 5
 Tutankhamun, 15, 18, 20, 23, 25, 28, 29, 46, 57, 58–59, 122, 131, 176
 Tutankhamun, tomb of, 206
 Uncial, 101
 Urdai, hall, 101
 Ürümchi, CP1, 5
 Uther Pendragon, 117, 120
 Van Allen belts, 11
 Vedas, n226
 Velikovsky, Immanuel, 13
 Venus, CP22, 58, 61, 68, 111, 112, 131, 133, 134, 149
 Vercingetorix, 47
 Vesica Pisces, CP3, CP9, 16, 17, 115, 159
 Vetusta Ecclesia, 90
 Vikings, 101, 179
 Viracocha Pachacamac, coffin of, 207
 Viracocha Pachacamac, CP5, CP24, 18, 21, 23, 25, 43, 182, 183, 184
 Viracocha Pachacamac, tomb of, 206
 Viracocha pattern, 161
 Viracocha transformer, 196–200, 201
 Viracocha vase, CP3, 158, 169, 176
 Viracocha, CP3, CP5, CP10, CP24, 15, 17, 42, 46, 106, 122, 137, 157, 159, 160, 161, 179, 183, 184, 185, 188, 189, 190
 Vishnu, n226
 Vita Columbae, 97
 Vortigern, 91
 Vulgate, 90, 102, 103
 Waterhouse, John W., CP18, 123, 128
 Well, 62, 69–70
 Willibrord, St., 111
 Wurzburg, 13
 Xipe Totec, CP3, CP4, 35
 Xiuhtechutli, CP10
 Yellow rim and nails, 165, 167
 Yin and Yang, 80
 Ynys Môn, 48

Zaghunluq, CP1, 5
 Zechariah, 63, 66
 Zedekiah, 63
 Zephaniah, 62, 66

Zeus, 39, 64, 65
 Zeus-Jupiter, 13
 Zion, Mount, 60, 63, 69

- Sunspots, 23, 51, 52
 Susanna, 65
 Swastika panels, secrets of, 163, 164,
 165, 178
 Swastika(s) 11, 12, 14, 186
 Swastikas, reverse(d), 8, 22, 25, 83
 Sykes, Professor Brian, 2
 Synod, 89
 Synod of Whitby, 98
 Taklamakan desert, CP11, 51, 54, 56
 Taprobane, 3
 Tara, 2
 Tara Brooch, CP20, CP21, CP22, 108,
 128, 130, 132, 134, 135, 138, 178,
 179
 Tarim, CP1, 4, 5
 Tatian, 88
 Tatian's Gospels, 88
 Tau cross, 154, 155, 156, 157, 178
 Telemon, 47
 Ten Commandments, 59, 60, 62, 71
 Teutons, 42
 Thomas, Gospel of, 66
 Three Worlds, 211
 Thutmose, 58
 Tiahuanaco, CP5, 158, 159, 169
 Tiber, 46
 Tigris, 54, 55, 57
 Torah, 59
 Torc 19, 36, 37, 39, 41
 Truth, Gospel of, 66, 88
 Tuatha Dé, 2
 Turkestan, 4, 5
 Tutankhamun, 15, 18, 20, 23, 25, 28,
 29, 46, 57, 58-59, 122, 131, 176
 Tutankhamun, tomb of, 206
 Ürümchi, CP1, 5
 Uther Pendragon, 117, 120
 Van Allen belts, 11
 Vedas, *n226*
 Velkovsky, Immanuel, 13
 Venus, CP22, 58, 61, 68, 111, 112, 131,
 133, 134, 149
 Vercingetorix, 47
 Vesica Pisces, CP3, CP9, 16, 17, 115,
 159
 Vetusta Ecclesia, 90
 Vikings, 101, 179
 Viracocha Pachacamac, coffin of, 207
 Viracocha Pachacamac, CP5, CP24,
 18, 21, 23, 25, 43, 182, 183, 184
 Viracocha Pachacamac, tomb of, 206
 Viracocha pattern, 161
 Viracocha transformer, 196-200, 201
 Viracocha vase, CP3, 158, 169, 176
 Viracocha, CP3, CP5, CP10, CP24, 15,
 17, 42, 46, 106, 122, 137, 157, 159,
 160, 161, 179, 183, 184, 185, 188,
 189, 190
 Vishnu, *n226*
 Vita Columbae, 97
 Vortigern, 91
 Vulgate, 90, 102, 103
 Waterhouse, John W., CP18, 123, 128
 Well, 62, 69-70
 Willibrod, St., 111
 Wurzburg, 13
 Xipe Totec, CP3, CP4, 35
 Xihuechutli, CP10
 Yellow rim and nails, 165, 167
 Yin and Yang, 80
 Ynys Môn, 48
 Zaghunluq, CP1, 5
 Zechariah, 63, 66
 Zedekiah, 63
 Zephaniah, 62, 66
 Zeus, 39, 64, 65
 Zeus-Jupiter, 13
 Zion, Mount, 60, 63, 69

Books of Related Interest

The Tutankhamun Prophecies

The Sacred Secret of the Maya, Egyptians, and Freemasons
by Maurice Cotterell

The Lost Tomb of Viracocha

Unlocking the Secrets of the Peruvian Pyramids
by Maurice Cotterell

The Terracotta Warriors

The Secret Codes of the Emperor's Army
by Maurice Cotterell

The Grail

The Celtic Origins of the Sacred Icon
by Jean Markale

King of the Celts

Arthurian Legends and Celtic Tradition
by Jean Markale

Mabon and the Guardians of Celtic Britain

Hero Myths in the Mabinogion
by Caitlín Matthews

The Mystery of the Grail

Initiation and Magic in the Quest for the Spirit
by Julius Evola

Walking the Maze

The Enduring Presence of Celtic Spirit
by Loren Cruden

Inner Traditions • Bear & Company

P.O. Box 388

Rochester, VT 05767

1-800-246-8648

www.InnerTraditions.com

Or contact your local bookseller

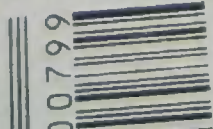

In 1989, while working at Cranfield University, engineer and scientist Maurice Cottrell found a way of calculating the location of long-term magnetic reversals on the Sun. Using this knowledge he was able to break the codes of ancient sun-worshipping civilisations—first the Mayas of Mexico, then of Tutankhamun of Egypt, and the Viracocha of South America, before cracking the codes of the Terracotta Warriors of China.

His own unique decoding process reveals amazing pictures from archaeological artefacts that explain the spiritual mysteries of life, why we are here, why we die and why this has to be.

His work, best described as a holistic art, brings together modern science, spirituality and ancient wisdom to unlock the secrets of the past, the present and the future.

In 1992 he was awarded the 'Nahuatlaco Cultural' medal, for his contributions to Mexican culture.

What they said about his books:

Excellent work!... Sergio Arango Garcia
Director INAH (Mexico Inst. of Archaeology)

Enough evidence to make even the most sceptical take note!... *The Daily Mail*

An amazing discovery!... *The Daily Express*

One of the most amazing books I have ever read!... Colin Wilson, Bestselling Author

Jacket photographs:
Front: Celtic chalice, rear: Tara brooch
(Reverse) © National Museum of Ireland

Cover by Maurice Cottrell

ISBN 0-911190-1-0

Books of Related Interest

The Tutankhamun Prophecies

The Sacred Secret of the Maya, Egyptians, and Freemasons
by Maurice Cottrell

The Lost Tomb of Viracocha

Unlocking the Secrets of the Peruvian Pyramids
by Maurice Cottrell

The Terracotta Warriors

The Secret Codes of the Emperor's Army
by Maurice Cottrell

The Grail

The Celtic Origins of the Sacred Icon
by John Markale

King of the Celts

Arthurian Legends and Celtic Tradition
by John Markale

Mabon and the Guardians of Celtic Britain

Hero Myths in the Mabinogion
by Caitlin Matthews

The Mystery of the Grail

Initiation and Magic in the Quest for the Spirit
by Julius Evola

Walking the Maze

The Enduring Presence of Celtic Spirit
by Loren Cruden

Inner Traditions • Bear & Company

P.O. Box 388

Rochester, VT 05767

1-800-246-8648

www.InnerTraditions.com

Or contact your local bookseller

In 1989, while working at Cranfield University, engineer and scientist Maurice Cotterell found a way of calculating the duration of long-term magnetic reversals on the Sun. Using this knowledge he was able to break the codes of ancient sun worshipping civilizations—first the Mayas of Mexico, those of Tutankhamun of Egypt, and the Viracochas' of South America, before cracking the codes of the Terracotta Warriors of China.

His own unique decoding process reveals amazing pictures from archaeological artefacts that explain the spiritual mysteries of life; why we are born, why we die and why this has to be.

His work, best described as *adventure fact*, brings together modern science, spirituality and ancient wisdom to unlock the secrets of the past, the present and the future.

In 1992 he was awarded the 'Voluntariado Cultural' medal, for his contributions to Mexican culture.

What they said about his books;

'Excellent work'... Sergio Arroyo Garcia,
Director INAH (Mexico Inst. of Archaeology)

'Enough evidence to make even the most sceptical take note'... *The Daily Mail*

'An amazing discovery'... *The Daily Express*

'One of the most amazing books I have ever read'... Colin Wilson, Bestselling Author

Jacket photographs:
front; Celtic chalice, rear; Tara brooch
[obverse] © National Museum of Ireland

Cover by Maurice Cotterell

ISBN 0 9513195 9 0

EMASONS

Express

Cotterell, the
... the footsteps
... and tomb of
... of Mexico,
... secrets of the
... ars.

... re sensational
... en robbed the
... of the middle
... hamun's father

... ishmun encoded
... as a message to

... evoled treasures of
... ell the same story

... as today, concealed
... reb and the higher

... ne ever, Maurice
... xcy, reasons why

... ever read in my life
... The Outsider

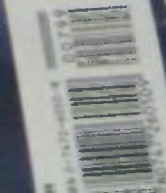

00794
9 7800794 00794

PLEASE SEND US THIS CARD TO RECEIVE OUR LATEST CATALOG

Book in which this card was found.

Check here if you would like to receive our catalog via e-mail.

Name _____ Company _____
Address _____ Phone _____
City _____ State _____ Zip _____ Country _____
E-mail address _____

Please check the following areas of interest to you:

- Health Self-help Science/Space Philosophy
- Ancient Mysteries New Age/Spirituality Education Medical Adv.
- Spanish Language Inventions/Tools Children Fun

Please send a catalog to me from:

Name _____ Company _____
Address _____ Phone _____
City _____ State _____ Zip _____ Country _____

Order at 1-800-390-3648 • Fax 650-357-6228
E-mail: order@newhorizonsbooks.com • Web site: www.newhorizonsbooks.com

In 1985, while working at Cranfield University, engineer and scientist Maurice Cotterell found a way of calculating the direction of long-term magnetic anomalies on the Sun. Using this knowledge he was able to break the codes of ancient non-overlapping civilisations—first the Minoan, then the Atlantean of Egypt, and the Vinichians of South America, before cracking the codes of the Neolithic Farmers of China.

His own unique decoding process reveals amazing pictures from archaeological artefacts that explain the spiritual mysteries of life; why we are here, why we die and why this has to be.

His work, best described as advanced Jain, brings together modern science, spiritually and ancient wisdom to unlock the secrets of the past, the present and the future.

In 1992 he was awarded the 'Simancas Cultural' medal, for his contributions to Mexican culture.

- What they said about his books:
- 'Excellent work'... Sergio Arce Garcia, Director INAH (Mexico Inst. of Archaeology)
 - 'Enough evidence to make even the most sceptical take note'... The Daily Mail
 - 'An amazing discovery'... The Daily Express
 - 'One of the most amazing books I have ever read'... Colin Wilson, bestselling author

Jacket photographs:
Front: Celtic chalice, rear: Tara brooch
[reversal] © National Museum of Ireland

Cover by Maurice Cotterell
ISBN 0 002 1190 9 0

In 1989, while working at Cranfield University, engineer and scientist Maurice Cottrell found a way of calculating the duration of long-term magnetic records on the Sun. Using this knowledge he was able to track the order of ancient sun-avoiding civilisations – from the Minoan of Greece, Rome of the Mediterranean of Egypt, and the Visigoths of South America, before cracking the codes of the Ancestral Masters of China.

His own unique decoding process reveals amazing pictures from archaeological artefacts that explain the spiritual systems of life, why we are born, why we die and why this happens.

His work, best described as alternative fact, brings together modern science, spirituality and ancient wisdom to unlock the secrets of the past, the present and the future.

In 1992 he was awarded the 'Sikandar Cultural' medal for his contributions to Mexican culture.

What they said about his books:

'Excellent work'... *Sergio Arroyo Garcia*
Director INAH (Mexico Inst of Archaeology)

'Enough evidence to make even the most sceptical take note'... *The Daily Mail*

'An amazing discovery'... *The Daily Express*

'One of the most amazing books I have ever read'... *Celia Wilson, Retelling Author*

Jacket photographs:
East, Celtic chalice, west, Tara brooch
(above) © National Museum of Ireland

Cover by Maurice Cottrell

ISBN 0 85205 810

INNER TRADITIONS
THE BEAR COMPANY



Inner Traditions • Bear Company
PO Box 388
Eschscholtz, VT 05761-0388
USA

INS
the
ship of
also,
of the
that
the
the
other
included
to alter
hours of
the story
uncovered
higher
average
which
my life
ere

The
CELTIC CHRONICLES

The true story of the Holy Grail

With his knowledge of how ancient civilizations encoded secrets into their treasures, best-selling author Maurice Cotterell now follows the trail of the Celts on an epic journey from the deserts of China, across Europe to Ireland.



Here lies the untold story of the most treasured relic of the Christian Church. A story that begins in Jerusalem with Joseph of Arimathea who carried the Holy Grail to England, and moves to Celtic Britain and King Arthur, who drew the sword from the stone and cracked the codes of the Celts to behold the cup of light.

The Author reveals how the cup passed to monks for safe-keeping, how it later inspired them to write the Lindisfarne Gospels and the Book of Kells, how they fled from Vikings—across the Irish Sea to the new monastery at Kells—and how it found its way to the National Museum of Ireland where it rests, alongside Excalibur, today.

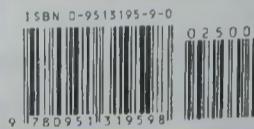

ANCIENT MYSTERIES/CELTIC STUDIES

\$16.00

Using the same knowledge that enabled him to break the codes of the Mayas, Peruvians, Egyptians, and Chinese, Maurice Cotterell now follows the migration of the Celts 4,000 years ago from Asia, across Europe, to Ireland. His account of this epic journey, combined with his knowledge of the secret codes of the Celts, help him identify and locate the Holy Grail, the actual cup used by Christ and his disciples at the Last Supper.

The author explains the true story of the Grail: how it contains the secret super-science of the sun and the higher orders of spirituality; how it was carried to England by Joseph of Arimathea; how in AD 453 it was found by King Arthur, who engraved it with the same esoteric information found on the Pyramid of Inscriptions in Palenque, Mexico, and the Gateway of the Sun at Tiahuanaco in ancient Peru. His discoveries reveal that the Grail does actually radiate light, in accordance with the Arthurian legends, proving that the so-called legends are actually based on fact. The author goes on to show how the holy cup was passed for safekeeping to the monks of Lindisfarne, who copied the secrets of the Grail into the Lindisfarne Gospels and the Book of Kells. Fleeing from Viking raids, the monks carried their treasures to Ireland, explaining how the cup found its way to the Dublin Museum—where it rests today.



MAURICE COTTERELL is the bestselling author of *The Tutankhamun Prophecies*, *The Mayan Prophecies*, *The Lost Tomb of Viracocha*, and *The Terracotta Warriors*. He lives in Ireland.



BEAR & COMPANY
ROCHESTER, VERMONT
www.BearandCompanyBooks.com

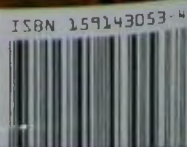

Cover design by Peri Champine
Cover illustrations courtesy of Corbis Images and
Art Resource

THE SIGNS BEFORE THE DAY OF JUDGEMENT

Author: Al-Haafidh Ibn Katheer Hadeeth
Checking: Abu Talhah Daawood Burbank

Ayaat and Ahaadeeth about the Hour

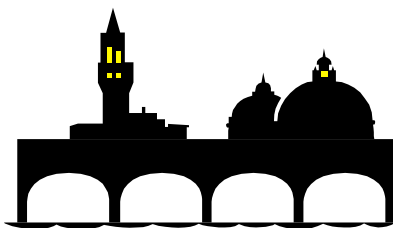



"My Lord! Increase me in knowledge!" - Qur'an 20:114"

Allaah (subhaanahu wa ta'aala) said:

"They ask you (O Muhammad sal-Allaahu 'alayhe wa sallam) about the Hour, - when will be its appointed time? You have no knowledge to say anything about it, To your Lord belongs (the knowledge of) the term thereof? You (O Muhammad sal-Allaahu 'alayhe wa sallam) are only a warner for those who fear it, The Day they see it, (it will be) as if they had not tarried (in this world) except an afternoon or a morning." [An-Nazi'aat (79):42-46]

"They ask you about the Hour (Day of Resurrection): 'When will be its appointed time?' Say: 'The knowledge thereof is with my Lord (Alone). None can reveal its time but He. Heavy is its burden through the heavens and the earth. It shall not come upon you except all of a sudden.' They ask you as if you have a good knowledge of it. Say: 'The knowledge thereof is with Allaah (Alone) but most of mankind know not.'" [Al-A'raaf (7):187]

There are many Ayaat and Ahaadeeth concerning this subject: Allaah said:

"The Hour has drawn near, and the moon has been cleft asunder." [Al-Qamar (54):1]

The Prophet (sal-Allaahu 'alayhe wa sallam) said, whilst pointing with his index and middle fingers,

"The time of my advent and the Hour are like these two fingers." [1]

In another report he said,

"The Hour almost came before me."

This indicates how close we are, relatively speaking, to the Hour.

Allaah said:

"Draws near for mankind their reckoning, while they turn away in heedlessness." [Al-Anbiyaa' (21):1]

"The Event (the Hour or the punishment of disbelievers and polytheists or the Islaamic laws or commandments), ordained by Allaah will come to pass, so seek not to hasten it. Glorified and Exalted be He above all that they associate as partners with Him." [An-Nahl (16):1]

"Those who believe not therein seek to hasten it, while those who believe are fearful of it, and know that it is the very truth. Verily, those who dispute concerning the Hour are certainly in error far away." [Ash-Shooraa (42):18]

In Saheeh al-Bukhaaree, there is a Hadeeth which states that a Bedouin asked the Prophet (sal-Allaahu 'alayhe wa sallam) about the Hour.

He (sal-Allaahu 'alayhe wa sallam) said,

"It will surely come to pass. What have you prepared for it?" The man said, "O Messenger of Allaah, I have not prepared much in the way of prayer and good works, but I love Allaah and His Messenger." The Prophet (sal-Allaahu 'alayhe wa sallam) said, "You will be with those you love." The Muslims had never rejoiced as much they did when they heard this Hadeeth. [2]

Some Ahaadeeth report that the Prophet (sal-Allaahu 'alayhe wa sallam) was asked about the Hour. He looked towards a young boy and said, "If he lives, he will not grow very old before he sees your Last Hour coming to you." [3]

By this he meant their death and entering the Hereafter, because everyone who dies enters the Hereafter; some people say that when a person has died, his judgment has begun. This Hadeeth with this meaning is "correct" (Saheeh).

Some heretics comment on this Hadeeth and give it an incorrect meaning. The exact timing of the Great Hour (as-Saa'at al-'Uzmaa) is something which Allaah alone knows and which He has not revealed to anyone, as is clear from the Hadeeth in which the Prophet (sal-Allaahu 'alayhe wa sallam) said:

"There are five things which nobody knows except Allaah;" then he recited, "Verily, Allaah! With Him (Alone) is the knowledge of the Hour, He sends down the rain, and knows that which is in the wombs. No person knows what he will earn tomorrow, and no person knows in what land he will die. Verily, Allaah is All Knower, All Aware (of things)."

[Luqman (31):34] [4]

When Gabriel (Jibreel) (alayhi-salaam) came to the Prophet (sal-Allaahu 'alayhe wa sallam) in the guise of a Bedouin, he asked him about Islaam, Eemaan (faith) and Ihsaan (excellence of faith); and the Prophet (sal-Allaahu 'alayhe wa sallam) answered his questions. But when he asked him about the Hour, he said,

"The one questioned about it knows no better than the questioner." Jibreel said, "Tell me about its signs." Then the Prophet (sal-Allaahu 'alayhe wa sallam) described them, as we shall see later when we quote this Hadeeth and others in full.

Hudhayfah said:

"The Prophet (sal-Allaahu 'alayhe wa sallam) stood up one day to speak to us, and told us everything that was going to happen until the Hour, and left nothing unsaid. Some of the listeners learnt it by heart, and some forgot it; these friends of mine learnt it. I do not remember it completely, but sometimes it springs to mind, just as one might remember and recognise the face of a man whom one had forgotten, when one sees him." [Abu Daawood, Muslim] [5]

Imaam Ahmad reported via Abu Nudrah that Abu Sa'eed said:

"One day the Prophet (sal-Allaahu 'alayhe wa sallam) led us in praying the afternoon prayer (Salaat al-'Asr). Then he stood and addressed us until sunset. He mentioned everything that was to happen until the Day of Resurrection, and left nothing unsaid. Some of us remembered it, and some of us forgot it. One of the things he said was:

'O people, this world is full of attractive temptations. Allaah has appointed you as vicegerents (Khaleefah) in this world, and He will see how you will act. So guard yourselves against the temptations of this world and of women.'

Towards the end of this speech, he said,

'The sun is about to set, and what remains of this world, compared to what has passed, is like what remains of this day compared to what has passed.' [6]"

'Alee ibn Zayd ibn Jad'an al-Timi narrated some Gharib and Munkar Ahaadeeth - which could bring into question the validity of this Hadeeth. But there are some reports which are similar to this Hadeeth, and which were transmitted with different isnaads. Part of this Hadeeth is in Saheeh Muslim, through Abu Nudrah on the authority of Abu Sa'eed. This Hadeeth refers to something which is beyond any doubt: what remains of this world, compared to what has passed, is very little. In spite of that, no-one can know exactly how much time is left except Allaah, and no-one can know exactly how much time has passed, except Allaah.

Footnotes

[1] Bukhaaree, Kitaab at-Tafsir, commentary on Surat an-Nazi'aat, 6/206.

[2] A similar Hadeeth was narrated by Bukhaaree in Kitaab al-Adab.

[3] See Bukhaaree, Kitaab al-Adab; Muslim, Kitaab al-Fitan wa Ashraat

al-Sa'ah.

[4] Bukhaaree, Kitaab at-Tafsir, commentary on Luqman 31:34. A longer Hadeeth is narrated by Muslim in Kitaab al-Eemaan.

[5] Muslim, Kitaab al-Fitan wa Ashraaat al-Sa'ah; Abu Daawood, Kitaab al-Fitan wa'l-Malahim.

[6] The whole speech is narrated by Imaam Ahmad in his Musnad, 2/61. Checker's Note: Da`eef, al-Musnad (3/61) [or 2/61 as stated in the book??], at-Tirmidhee and al-Hakim (4/505). Da`eef due to `Alee ibn Zayd ibn Jad'an. al-Mishkat: 5145 of al-Albaanee. Parts of the complete speech are authentic, see Ibn Kathir's comments.

General Description of the Fitan (Tribulations)

Hudhayfah ibn al-Yaman said,

"People used to ask the Prophet (sal-Allaahu 'alayhe wa sallam) about good things, but I used to ask him about bad things because I was afraid that they might overtake me. I said, 'O Messenger of Allaah, we were lost in ignorance (Jahiliyyah) and evil, then Allaah brought this good (i.e. Islaam). Will some evil come after this good thing?' He said, 'Yes' I asked, 'And will some good come after that evil?' He said, 'Yes, but it will be tainted with some evil' I asked, 'How will it be tainted?' He said, 'There will be some people who will lead others on a path different from mine. You will see good and bad in them.'" I asked, 'Will some evil come after that good?' He said, 'Some people will be standing and calling at the gates of Hell; whoever responds to their call, they will throw him into the Fire.' I said, 'O Messenger of Allaah, describe them for us.' He said, 'They will be from our own people, and will speak our language.' I asked, 'What do you advise me to do if I should live to see that?' He said, 'Stick to the main body (jamaa'ah) of the Muslims and their leader (Imaam). I asked, 'What if there is no main body and no leader?' He said 'Isolate yourself from all of these sects, even if you have to eat the roots of trees until death overcomes you while you are in that state.' [1]"

'Abd Allaah ibn Mas'ood said:

"The Prophet (sal-Allaahu 'alayhe wa sallam) said, 'Islaam began as something strange, and it will revert to being strange as it was in the beginning, so good tidings for the strangers.' Someone asked, 'Who are the strangers?' He said, 'The ones who break away from their people (literally, 'tribes') for the sake of Islaam.'" This Hadeeth was narrated by Ibn Majah on the authority of Anas and Abu Hurairah. [2]

Footnotes

[1] Bukhaaree, Kitaab al-Fitan, 9/65.

[2] Muslim, Kitaab al-Eemaan, 1/90: Ibn Majah, Kitaab al-Fitan (Hadeeth 3988), 2/1320.

Divisions Within the Main Religious Groups

Abu Hurairah reported that the Prophet (sal-Allaahu 'alayhe wa sallam) said:

"The Jews have split into seventy-one sects, and my Ummah will divide into seventy-three." [1]

'Awf ibn Malik reported that the Prophet (sal-Allaahu 'alayhe wa sallam) said:

"The Jews split into seventy-one sects: one will enter Paradise and seventy will enter Hell. The Christians split into seventy-two sects: seventy-one will enter Hell and one will enter Paradise. By Him in Whose hand is my soul, my Ummah will split into seventy-three sects: one will enter Paradise and seventy-two will enter Hell." Someone asked, "O Messenger of Allaah, who will they be?" He replied, "The main body of the Muslims (al-Jamaa'ah)."

'Awf ibn Malik is the only one who reported this Hadeeth, and its isnaad is acceptable. [2]

Anas ibn Malik said,

"I shall tell you a Hadeeth which I heard from the Messenger of Allaah, and which no-one will tell you after me. I heard him say, 'Among the signs of the Hour will be the disappearance of knowledge and the appearance of ignorance. Adultery will be prevalent and the drinking of wine will be common. The number of men will decrease and the number of women will increase until there will be fifty women to be looked after by one man.'" This Hadeeth was reported in the two Saheehs from the Hadeeth of 'Abd Rabbihi. [3]

'Abd Allaah said,

"The Prophet (sal-Allaahu 'alayhe wa sallam) said, 'Just before the Hour, there will be days in which knowledge will disappear and ignorance will appear, and there will be much killing.' " [Ibn Maajah; also narrated by Bukhaaree and Muslim, from the Hadeeth of al-A'mash] [4]

Hudhayfah ibn al-Yaman said,

"The Prophet (sal-Allaahu 'alayhe wa sallam) said, 'Islaam will become worn out like clothes are, until there will be no-one who knows what fasting, prayer, charity and rituals are. The Qur'aan will disappear in one night, and no Ayah will be left on earth. Some groups of old people will be left who will say, 'We heard our fathers saying La ilaha illa Allaah, so we repeated it.' Silah asked Hudhayfah, "What will saying La ilaha illa Allaah do for them when they do not know what prayer, fasting, ritual and charity

are?" Hudhayfah ignored him; then Silah repeated his question three times, and each time Hudayfah ignored him. Finally he answered, "O Silah, it will save them from Hell", and said it three times. [Ibn Maajah] [5] This indicates that in the last days, knowledge will be taken from the people, and even the Qur'aan will disappear from the Mushafs and from people's hearts. People will be left without knowledge. Only the old people will tell them that they used to hear people saying La ilaha illa Allaah; and they will repeat it to feel close to Allaah, so it will give them some blessing, even if they do not have any good deeds or beneficial knowledge. Knowledge will be taken away from men and ignorance will increase during the last days, and their ignorance and misguidance will increase until the end, as in the Hadeeth of the Prophet (sal-Allaahu 'alayhe wa sallam):

"The Hour will not come upon anyone who says, 'Allaah, Allaah'; it will only come upon the most evil of men." [6]

Footnotes

[1] Ibn Maajah, Kitaab al-Fitan (Hadeeth 3991), 2/1321.

Checker's Note: Saheeh, Saheeh Ibn Maajah: 3225

[2] Abu Daawood, Kitaab as-Sunnah, (Hadeeth 4572, 4573), 12/1340-2. "The main body of the Muslims (al-Jamaa'ah)" means the people of the Qur'aan, Hadeeth, Fiqh and other sciences, who have agreed to follow the Traditions of the Prophet (sal-Allaahu 'alayhe wa sallam) in all circumstances without introducing any changes or imposing their own confused ideas.

Checker's Note: Saheeh, Saheeh al-Jami as-Sagheer: 1082, the narration of `Awf ibn Malik is also reported by Ibn Maajah (no. 4992), Ibn Abee `Asim in as-Sunnah (no. 63) and al-Lalikai in Sharh us-Sunnah (no. 1492).

[3] A similar Hadeeth was narated by al-Bukhaaree in Kitaab al-'Ilm, 1/30,31; and by Muslim.

Checker's Note: Saheeh, al-Bukhari and Muslim.

[4] Bukhaaree, Kitaab al-Fitan, 9/61; Msulim, Kitaab al-'Ilm, 8/58.

[5] Checker's Note: Saheeh, Silsilatul Ahadeeth as-Saheehah: 87.

[6]The first part of it was related by Muslim in Kitab al-Eemaan, 1/91, and the second part in Kitab al-Fitan wa Ashraat al-Sa'ah, 8/208.

The Evils Which Will Befall the Muslim Ummah During The Last Days 'Abd Allaah ibn 'Umar said,

"The Prophet (sal-Allaahu 'alayhe wa sallam) came to us and said, 'O Muhaajiroon, (emigrants from Makkah to al-Madinah) you may be

afflicted by five things; God forbid that you should live to see them. If fornication should become widespread, you should realise that this has never happened without new diseases befalling the people which their forebears never suffered. If people should begin to cheat in weighing out goods, you should realise that this has never happened without drought and famine befalling the people, and their rulers oppressing them. If people should withhold Zakaat, you should realise that this has never happened without the rain being stopped from falling; and were it not for the animals' sake, it would never rain again. If people should break their covenant with Allaah and His Messenger, you should realise that this has never happened without Allaah sending an enemy against them to take some of their possessions by force. If the leaders do not govern according to the Book of Allaah, you should realise that this has never happened without Allaah making them into groups and making them fight one another." [Ibn Maajah] [1]

'Alee ibn Abee Taalib said,

"The Prophet (sal-Allaahu 'alayhe wa sallam) said: 'If my Ummah bears fifteen traits, tribulation will befall it.' Someone asked, 'What are they, O Messenger of Allaah?' He said, 'When any gain is shared out only among the rich, with no benefit to the poor; when a trust becomes a means of making a profit; when paying Zakaat becomes a burden; when a man obeys his wife and disobeys his mother; and treats his friend kindly whilst shunning his father; when voices are raised in the mosques; when the leader of a people is the worst of them; when people treat a man with respect because they fear some evil he may do; when much wine is drunk; when men wear silk; when female singers and musical instruments become popular; when the last ones of this Ummah curse the first ones - then let them expect a red wind, or the earth to swallow them, or to be transformed into animals.'" [Tirmidhee] [2]

'Alee ibn Abee Taalib said,

"The Prophet (sal-Allaahu 'alayhe wa sallam) led us in praying Salaat al-Fajr (the morning prayer). When he had finished, a man called to him: 'When will the Hour be? The Prophet (sal-Allaahu 'alayhe wa sallam) reprimanded him and said 'Be quiet!' After a while he raised his eyes to the sky and said, 'Glorified be the One Who raised it and is taking care of it.' Then he lowered his gaze to the earth and said, 'Glory be to the One Who has outspread it and has created it.' Then the Prophet (sal-Allaahu 'alayhe wa sallam) said, 'Where is the one who asked me about the Hour?' The man knelt down and said, 'I asked you.' The Prophet (sal-Allaahu 'alayhe wa sallam) said, 'The Hour will come when leaders are

oppressors, when people believe in the stars and reject al-Qadar (the Divine Decree of destiny) when a trust becomes a way of making a profit, when people give to charity (Sadaqah) reluctantly, when adultery becomes widespread - when this happens, then your people will perish."
[3]

'Imran ibn Husayn said,

"The Prophet (sal-Allaahu 'alayhe wa sallam) said, 'Some people of this Ummah will be swallowed up by the earth, some will be transformed into animals, and some will be bombarded with stones.' One of the Muslims asked, 'When will that be, O Messenger of Allaah?' He said, 'When singers and musical instruments will become popular, and much wine will be drunk.'"[4]

Footnotes

[1] Narrated by Ibn Maajah, Kitaab al-Fitan (Hadeeth 4019), 2/1332.

Checker's Note: Saheeh, Silsilatul Ahadeeth as-Saheehah: 106-107.

[2] Tirmidhee, Abwaab al-Fitan (Hadeeth 308), 6/4620-458.

Checker's Note: Da`eef, Da`eef al-Jami as-Sagheer: 608.

[3] al-Haythami, Kitaab al-Fitan.

Checker's Note: al-Haythami, says, "al-Bazzar reports it and it contains narrators I do not know." We do not know the status of the hadeeth as no muhaddith (as far as we know) has given a definite verdict.

[4] Narrated by at-Tirmidhee.

Checker's Note: Saheeh, Silsilatul Ahadeeth as-Saheehah: 1604.

The Greater Signs of the Hour

After the lesser signs of the Hour appear and increase, mankind will have reached a stage of great suffering. Then the awaited Mahdee will appear; he is the first of the greater, and clear, signs of the Hour. There will be no doubt about his existence, but this will only be clear to the knowledgeable people. The Mahdee will rule until the False Messiah (al-Maseeh ad-Dajjal) appears, who will spread oppression and corruption. The only ones who will know him well and avoid his evil will be those who have great knowledge and Eemaan (faith).

The false Messiah will remain for a while, destroying mankind completely, and the earth will witness the greatest Fitnah (tribulation) in its history. Then the Messiah Jesus (alayhi salam) will descend, bringing justice from heaven. He will kill the Dajjal, and there will be years of safety and security.

Then the appearance of Ya'jooj and Ma'jooj (Gog and Magog) will take mankind by surprise, and corruption will overtake them again. In answer

to Jesus' faithful prayer to Allaah (subhanahu wa ta'aala), they will die, and safety, security, justice and stability will return.

This state of affairs will continue for some years, until the death of Jesus. The Ulamaa differ concerning the order in which the other greater signs of the Hour will come about. They are:

- The destruction of the Ka'bah and the recovery of its treasure.
- The rising of the sun from the west.
- The emergence of the Beast from the earth.
- The smoke.
- A wind will take the souls of the believers.
- The Qur'aan will be taken up into heaven.
- A fire will drive the people to their last gathering place.
- The Trumpet will be sounded: at the first sound everyone will feel terror; at the second sound all will be struck down; at the last sound all will be resurrected.

The Mahdee

The Mahdee will come at the end of time; he is one of the Rightly-Guided Caliphs and Imaams. He is not the Mahdee who is expected by the Shee'ah, who they claim will appear from a tunnel in Saamarraa. This claim of theirs has no basis in reality nor in any reliable source. They allege that his name is Muhammad ibn al-Hasan ibn al-Askaree, and that he went into the tunnel when he was five years old.

The matter we intend to discuss has been proven by Ahaadeeth narrated from the Prophet (sal-Allaahu 'alayhe wa sallam): that the Mahdee will appear at the end of time. I believe that he will appear before Jesus the son of Mary comes down, as the Ahaadeeth indicate.

Hajjaaj said that he heard Alee say,

"The Prophet (sal-Allaahu 'alayhe wa sallam) said, "Even if there were only one day left for the world, Allaah would send a man from among us to fill the world with justice, just as it had been filled with oppression and justice." [Ahmad] [1]

Alee said,

"The Prophet (sal-Allaahu 'alayhe wa sallam) said, "The Mahdee is one of us, from among the people of my household. In one night Allaah will inspire him and prepare him to carry out his task successfully." [Ahmad and Ibn Maajah] [2]

Alee said, whilst looking at his son al-Hasan,

This son of mine is a Sayyid (master), as the Prophet (sal-Allaahu 'alayhe wa sallam) named him. Among his descendants there will be man named after your Prophet (sal-Allaahu 'alayhe wa sallam). He will resemble him

in behaviour but not in looks. Then he told them the report which mentions that the earth will be filled with justice. [Abu Daawood] [3]

Abu Daawood devoted a chapter of his Sunan to the subject of the Mahdee. At the beginning of this chapter he quoted the Hadeeth of Jaabir ibn Samrah, in which the Prophet (sal-Allaahu 'alayhe wa sallam) said, "This religion will remain steadfast until twelve caliphs have ruled over you." (According to another report he said, "This religion will remain strong until twelve caliphs have ruled over you.") Jaabir said, "The people cheered and shouted Allaahu Akbar! Then the Prophet (sal-Allaahu 'alayhe wa sallam) whispered something. I asked my father 'What did he say?' My father said, 'He said, All of them will be from Quraysh.'" Another report says that when the Prophet (sal-Allaahu 'alayhe wa sallam) returned to his house, Quraysh came to him and asked, "What will happen after that?" He said, "Then there will be tribulation and killing." [4]

Abu Daawood reported a Hadeeth from Abd Allaah ibn Masood: "The Prophet (sal-Allaahu 'alayhe wa sallam) said, "If there were only one day left for the world, that day would be lengthened until a man from among my descendants or from among the people of my household, was sent; his name will be the same as my name, and his fathers name will be the same as my fathers name. He will fill the earth with justice and fairness, just as it will have been filled with injustice and oppression. The world will not end until a man of my household, whose name is the same as mine, holds sway." [5]

Abd Allaah said, "The Prophet (sal-Allaahu 'alayhe wa sallam) said, 'A man from my household, whose name is like mine, will take power.'" [Tirmidhee] [6]

In another report, from Abu Hurairah, the Prophet (sal-Allaahu 'alayhe wa sallam) said, "If there were only one day left for this world, Allaah would lengthen it until he took power." [7]

Aboo Sa'eed said, "The Prophet (sal-Allaahu 'alayhe wa sallam) said, 'The Mahdee will be one of my descendants; he will have a high forehead and a hooked nose. He will fill the earth with justice and fairness just as it was filled with injustice and oppression, and he will rule for seven years.'" [Abu Daawood] [8]

Umm Salamah said, "I heard the Prophet (sal-Allaahu 'alayhe wa sallam) say, 'The Mahdee will be one of my descendants, from the children of Faatimah.'" [Abu Daawood] [9]

Umm Salamah reported that the Prophet (sal-Allaahu 'alayhe wa sallam) said,

"People will begin to differ after the death of a Khaleefah. A man from the people of Madinah will flee to Makkah. Some of the people of Makkah will come to him and drag him out against his will; they will swear allegiance to him between al-Rukn and al-Maqam. An army will be sent against him from Syria; it will be swallowed up in the desert between Makkah and Madinah. When the people see this, groups of people from Syria and Iraq will come and swear allegiance to him. Then a man from Quraysh whose mother is from Kalb will appear and send an army against them, and will defeat them; this will be known as the Battle of Kalb. Whoever does not witness the spoils of this battle will miss much! The Mahdee will distribute the wealth, and will rule the people according to the Sunnah of the Prophet (sal-Allaahu 'alayhe wa sallam). Then he will die, and the Muslims will pray for him." [Abu Daawood] [10]

Alee said,

"The Prophet (sal-Allaahu 'alayhe wa sallam) said, 'A man named al-Haarith ibn Hirath will come from Transoxania. His army will be led by a man named Mansoor. He will pave the way for and establish the government of the family of Muhammad, just as Quraysh established the government of the Messenger of Allaah. Every believer will be obliged to support him.'" [Abu Daawood] [11]

Abd Allaah ibn al-Haarith ibn Juz' al-Zubaydee said,

"The Prophet (sal-Allaahu 'alayhe wa sallam) said, 'A people will come out of the East who will pave the way for the Mahdee.'" [Ibn Maajah] [12]

Abd Allaah said,

"Whilst we were with the Prophet (sal-Allaahu 'alayhe wa sallam), some young men from Banu Hashim approached us. When the Prophet (sal-Allaahu 'alayhe wa sallam) saw them, his eyes filled with tears and the colour of his face changed. I said, 'We can see something has changed in your face, and it upsets us.' The Prophet (sal-Allaahu 'alayhe wa sallam) said, 'We are the people of a Household for whom Allaah has chosen the Hereafter rather than this world. The people of my Household (Ahl al-Bayt) will suffer a great deal after my death, and will be persecuted until a people carrying black banners will come out of the east. They will instruct the people to do good, but the people will refuse; they will fight until they are victorious, and the people do as they asked, but they will not accept it from them until they hand over power to a man from my household. Then the earth will be filled with fairness, just as it had been filled with injustice. If any of you live to see this, you should go

to him even if you have to crawl across ice." [13]

This text refers to the rule of the Abbasids, as we have mentioned above in the text referring to the beginning of their rule in 132 AH. It also indicates that the Mahdee will appear after the Abbasids, and that he will be one of the Ahl al-Bayt, a descendant of Faatimah, the daughter of the Prophet (sal-Allaahu 'alayhe wa sallam), through Hasan, not Husayn, as mentioned in the Hadeeth from Alee ibn Abee Taalib; and Allaah knows best. [14]

Thwaban said,

"The Prophet (sal-Allaahu 'alayhe wa sallam) said, 'Three men will be killed at the place where your treasure is. Each of them will be the son of a Khaleefah, and none of them will get hold of the treasure. Then the black banners will come out of the East, and they will slaughter you in a way which has never been seen before.' Then he said something which I do not remember; then, 'If you see him, go and give him your allegiance, even if you have to crawl over ice, because he is the Khaleefah of Allaah, the Mahdee.'" [Ibn Maajah] [15]

The treasure referred to in this text is the treasure of the Ka'bah. Towards the end of time, three of the sons of the Khaleefahs will fight to get hold of it, until the Mahdee appears. He will appear from the East, not from the tunnel of Saamarraa, as the Shee'ah claim; they believe that he is in this tunnel now, and they are waiting for him to emerge at the end of time.

There is no evidence for it in any book or Saheeh tradition, and there is no benefit in believing this.

The truth of the matter is that the Mahdee whose coming is promised at the end of time will appear from the East, and people will swear allegiance to him at the Ka'bah, as some Ahaadeeth indicate.

At the time of the Mahdee, there will be peace and prosperity, with abundant crops and wealth, strong rulers, and Islaam will be well-established.

Aboo Sa'eed said,

"By Allaah every ruler we have had has been worse than the previous one, and every year has been worse than the year before, but I heard the Prophet (sal-Allaahu 'alayhe wa sallam) say, 'Among your rulers will be one who will give out wealth freely, without counting it. A man will come and ask him for money, and he will say, "Take"; the man will spread his cloak out and the ruler will pour money into it.' The Prophet (sal-Allaahu 'alayhe wa sallam) spread out a thick cloak he had been wearing, to demonstrate the mans actions; then he gathered it up by its corners and said, 'Then the man will take it and leave.'" [Ahmad] [16]

Footnotes

[1] Ahmad, al-Musnad; similar Hadeeth in Abu Daawood, Kitaab Awwal al-Mahdee.

Checker's Note: Saheeh, Ahmad and Abu Daud, Saheeh al-Jami as-Sagheer: 5305.

[2] Ahmad, al-Musnad and Ibn Maajah, Kitaab al-Fitan.

Checker's Note: Saheeh Saheeh al-Jami as-Sagheer: 6735. It has been mistranslated slightly, it should be "In one night, Allaah will prepare him," the mention of inspiration and the carrying out of the task is explanatory.

[3] See Abu Daawood, Kitaab al-Mahdee.

Checker's Note: Da`eef Munqati' (chain of narration is broken), al-Mishkat, 1st checking: 5462.

[4] Checker's Note: "... returned to his house" is a da`eef addition. The rest of the hadeeth is saheeh.

[5] See Abu Daawood, Kitaab al-Mahdee.

Checker's Note: Saheeh, Saheeh Abee Daawood: 3601.

[6] Checker's Note: "A man from my household ..." Hasan, Saheeh al-Jami as-Sagheer: 8160.

[7] at-Tirmidhee, in his chapters dealing with al-Fitan.

Checker's Note: Saheeh, Saheeh at-Tirmidhee: 1819.

[8] Abu Daawood, Kitaab al-Mahdee.

Checker's Note: Hasan, Saheeh Abee Daawood: 3604. Translation states, "... a hooked nose." Correct translation is "... an aquiline nose."

[9] Abu Daawood, Kitaab al-Mahdee.

Checker's Note: Saheeh, Saheeh Abee Daawood: 3603.

[10] Abu Daawood, Kitaab al-Mahdee.

Checker's Note: Da`eef, al-Mishkat, 1st checking: 5456.

[11] Checker's Note: Da`eef, Da`eef al-Jami as-Sagheer: 6418.

[12] Ibn Maajah, Kitaab al-Fitan (Hadeeth 3088).

Checker's Note: Da`eef, Silsilatul Ahaadeeth ad-Da`eefah: 4826.

[13] Ibn Maajah, ibid., (Hadeeth 4082).

Checker's Note: Da`eef, Da`eef Ibn Maajah: 886.

[14] See Ahaadeeth above. (Ref. 1, 2 & 3)

Checker's Note: Footnote refers to hadeeth no. 3.

[15] Narrated by Ibn Maajah, op. cit., Hadeeth 4084.

Checker's Note: Da`eef Munkar (the isnaad is weak and moreover the meaning is wrong). In this case, the mention of "Khaleefah of Allaah" is munkar because Allaah cannot have a successor or vicegerent in His absence, Silsilatul Ahaadeeth ad-Da`eefah: 85.

[16] Ahmad, Musnad, 3/98.

Checker's Note: Da`eef. Its isnaad contains Mujahid ibn Sa'eed
Different Kinds of Fitan (Tribulations)

Zaynab bint Jahsh said,

"The Prophet (sal-Allaahu 'alayhe wa sallam) got up from his sleep; his face was flushed and he said, 'There is no god but Allaah. Woe to the Arabs, for a great evil which is nearly approaching them. Today a gap has been made in the wall of Gog and Magog like this (Sufyan illustrated this by forming the number of 90 or 100 with his fingers).' Someone asked, 'Shall we be destroyed even though there are righteous people among us?' The Prophet (sal-Allaahu 'alayhe wa sallam) said, 'Yes, if evil increases.'" [Bukhaaree] [1]

Umm Salamah, the wife of the Prophet (sal-Allaahu 'alayhe wa sallam) said,

"One night the Prophet (sal-Allaahu 'alayhe wa sallam) got up and said, 'SubhanAllaah! How many tribulations have come down tonight, and how many treasures have been disclosed! Go and wake the dwellers of these apartments (i.e. his wives) for prayer. A well-dressed soul in this world may be naked in the Hereafter.'" [Bukhaaree] [2]

Usamah ibn Zayd said,

"Once the Prophet (sal-Allaahu 'alayhe wa sallam) stood over one of the battlements of al-Madinah and asked the people, 'Do you see what I see?' They said, 'No.' He said, 'I see afflictions falling upon your houses as rain drops fall.'" [Bukhaaree and Muslim] [3]

Abu Hurairah (radiallahu anhu) said,

"The Prophet (sal-Allaahu 'alayhe wa sallam) said, 'Time will pass rapidly, knowledge will decrease, miserliness will become widespread in peoples hearts, afflictions will appear, and there will be much Harj.' The people asked, 'O Messenger of Allaah, what is Harj?' He said, 'Killing, killing!'" [Bukhaaree] [4]

Al-Zubayr ibn Adee narrated,

"We went to Anas ibn Malik and complained about the wrong we were suffering at the hands of al-Hajjaaj. Anas ibn Malik said, 'Be patient, "For no time will come but that the time following it will be worse, until you meet your Lord." I heard the Prophet (sal-Allaahu 'alayhe wa sallam) say that.'" [Bukhaaree]

Abu Hurairah said,

"The Prophet (sal-Allaahu 'alayhe wa sallam) said, 'There will come a time of afflictions when one who sits will be better than one who stands; one who stands will be better than one who walks; and one who walks

will be better than one who runs. Whoever exposes himself to these afflictions, they will destroy him. So whoever can find a place of protection or refuge from them, should take shelter in it." [Bukhaaree and Muslim] [5]

Hudhayfah said,

"The Prophet (sal-Allaahu 'alayhe wa sallam) told us two Hadeeth, one of which I have seen fulfilled, and I am waiting for the fulfilment of the other. The Prophet (sal-Allaahu 'alayhe wa sallam) told us that honesty came down into mens hearts (from Allaah); then they learnt it from the Qur'aan, and then from the Sunnah. The Prophet (sal-Allaahu 'alayhe wa sallam) told us that honesty would be taken away. He said, 'Man will be overtaken by sleep, during which honesty will be taken away from his heart, and only its trace will remain, like traces of a dark spot. Then man will be overtaken by slumber again, during which honesty will decrease still further, until its trace will resemble a blister such as is caused when an ember is dropped onto ones foot: it swells, but there is nothing inside. People will be carrying on with their trade, but there will hardly be any trustworthy persons. People will say, There is an honest man in such-and-such a tribe. Later they will say about some man, What a wise, polite and strong man he is! - although he will not have faith even the size of a mustard-seed in his heart.' Indeed, there came a time when I did not mind dealing with any one of you, for if he were a Muslim his Islaam would compel him to pay whatever he owed me, and if he were a Christian, the Muslim official would compel him to pay it. But now I do not deal with anyone except so-and-so and so-and-so." [Bukhaaree] [6]

Ibn Umar said,

"The Prophet (sal-Allaahu 'alayhe wa sallam) stood beside the pulpit, facing the east, and said, 'Afflictions will verily emerge from here, where the top of Satans head will appear.'" [Bukhaaree] [7]

Abu Hurairah said that he had heard the Prophet (sal-Allaahu 'alayhe wa sallam) say,

"The Hour will not come until a man passes by someone's grave and says, 'Would that I were in his place!'" [Bukhaaree] [8]

Abu Hurairah said,

"I heard the Prophet (sal-Allaahu 'alayhe wa sallam) say, 'The Hour will not come until the buttocks of the women of Daws move whist going around Dhoo l-Khalasah.'" Dhoo l-Khalasah was an idol worshipped by the tribe of Daws during the Jaahiliyyah. [Hadeeth from Bukhaaree] [9]

Abu Hurairah also said,

"The Prophet (sal-Allaahu 'alayhe wa sallam) said, 'The Euphrates will

disclose a golden treasure. Whoever is present at that time should not take anything of it." [10]

Abu Hurairah said,

"The Prophet (sal-Allaahu 'alayhe wa sallam) said, 'The Hour will not come before the Euphrates uncovers a mountain of gold, for which people will fight. Ninety-nine out of every hundred will die, but every one among them will say that perhaps he will be the one who will survive (and thus possess the gold).'" [Muslim] [11]

Abu Hurairah said,

"The Prophet (sal-Allaahu 'alayhe wa sallam) said, 'The Hour will not come until the following events have come to pass: two large groups will fight the another, and there will be many casualties; they will both be following the same religious teaching. Nearly thirty Dajjaals will appear, each of them falsely claiming to be a Messenger from Allaah. Knowledge will disappear, earthquakes will increase, time will pass quickly, afflictions will appear, and Harj (ie killing) will increase. Wealth will increase, so that a wealthy man will worry lest no-one accept his Zakaat, and when he offers it to anyone, that person will say, "I am not in need of it." People will compete in constructing high buildings. When a man passes by someones grave, he will say, "Would that I were in his place!" The sun will rise from the west; when it rises and the people see it, they will believe, but,

"No good will it do to a soul to believe in them then, if it believed not before nor earned righteousness through its faith..." [Al-An'aam (6):158]

"The Hour will come suddenly: when a man has milked his she-camel and taken away the milk, but he will not have time to drink it; before a man repairing a tank for his livestock will be able to put water in it for his animals; and before a man who has raised a morsel of food to his mouth will be able to eat it." [Bukhaaree] [12]

Hudhayfah ibn al-Yaman said,

"Of all the people, I know most about every tribulation which is going to happen between now and the Hour. This is not because the Prophet (sal-Allaahu 'alayhe wa sallam) told me something in confidence which he did not tell anyone else; it is because I was present among a group of people to whom he spoke about the tribulations (al-Fitan). The Prophet (sal-Allaahu 'alayhe wa sallam) mentioned three tribulations which would hardly spare anybody, and some which would be like storms in summer; some would be great and some would be small. Everyone who was present at that gathering has passed away, except me." [Muslim] [13]

Abu Hurairah said,

"I heard the Prophet (sal-Allaahu 'alayhe wa sallam) say, "If you live for a while, you will see people go out under the wrath of Allaah and come back under His curse, and they will have in their hands whips like the tail of an ox." [Ahmad, Muslim] [14]

Abu Hurairah said,

"The Prophet (sal-Allaahu 'alayhe wa sallam) said, 'There are two types among the people of Hell whom I have not yet seen. The first are people who have whips like the tails of oxen, with which they beat people, and the second are women who are naked in spite of being dressed; they will be led astray and will lead others astray, and their heads will look like camels humps. These women will not enter Paradise; they will not even experience the faintest scent of it, even though the fragrance of Paradise can be perceived from such a great distance.'" [15]

Anas ibn Malik said,

"The Prophet (sal-Allaahu 'alayhe wa sallam) was asked, 'O Messenger of Allaah, (what will happen) when we stop enjoining good and forbidding evil?' He said, 'When what happened to the Israelites happens among you: when fornication becomes widespread among your leaders, knowledge is in the hands of the lowest of you, and power passes into the hands of the least of you.'" [Ibn Maajah] [16]

Abu Hurairah said,

"The Prophet (sal-Allaahu 'alayhe wa sallam) said, 'Woe to the Arabs from the great evil which is nearly approaching them: it will be like patches of dark night. A man will wake up as a believer, and be a kafir (unbeliever) by nightfall. People will sell their religion for a small amount of worldly goods. The one who clings to his religion on that day will be as one who is grasping an ember - or thorns.'" [Ahmad] [17]

Abu Hurairah said,

"I heard the Prophet (sal-Allaahu 'alayhe wa sallam) saying to Thawbaan, 'O Thawban, what will you do when the nations call one another to invade you as people call one another to come and eat from one bowl?'

Thawbaan said, 'May my father and my mother be sacrificed for you, O Messenger of Allaah! Is it because we are so few?' The Prophet (sal-Allaahu 'alayhe wa sallam) said, 'No, on that day you (Muslims) will be many, but Allaah will put weakness (wahn) in your hearts.' The people asked, 'What is that weakness, O Messenger of Allaah?' He said, 'It is love for this world and dislike of fighting.'" [Ahmad] [18]

The Prophet (sal-Allaahu 'alayhe wa sallam) said,

"There will be a tribulation in which one who is sleeping will be better than one who is lying down, one who is lying will be better than one who is

sitting, one who is sitting will be better than one who is standing, one who is standing will be better than one who is walking, one who is walking will be better than one who is riding, and one who is riding will be better than one who is running; all of their dead will be in Hell." The Companion of the Prophet (sal-Allaahu 'alayhe wa sallam) who narrated this Hadeeth said, "O Messenger of Allaah, when will that be?" He said, "That will be the days of Harj." He asked, "When will the days of Harj be?" The Prophet (sal-Allaahu 'alayhe wa sallam) said, "When a man will not trust the person to whom he is speaking." The Companion asked, "What do you advise me to do if I live to see that?" He said, "Restrain yourself, and go back to your place of residence." The Companion then asked, "O Messenger of Allaah, what should I do if someone enters my neighbourhood to attack me?" He said, "Go into your house." The Companion asked, "What if he enters my house?" He said, "Go into the place where you pray and do this - and he folded his arms, - and say 'My Lord is Allaah', until you die." [19]

Abu Bakrah said,

"The Prophet (sal-Allaahu 'alayhe wa sallam) said, 'There will be a tribulation during which one who is lying down will be better than one who is sitting, one who is sitting will be better than one who is standing, one who is standing will be better than one who is walking, and one who is walking will be better than one who is running.' Someone asked, 'O Messenger of Allaah, what do you advise me to do?' He said, 'Whoever has camels, let him stay with them, and whoever has land, let him stay in his land.' Someone asked, 'What about someone who does not have anything like that?' He said, 'Then let him take his sword and strike its edge against a stone, then go as far away as possible.'" [Abu Daawood; similar Hadeeth in Muslim] [20]

At the time of the Fitnah of Uthmaan ibn Affaan's Khilaafah (Caliphate), Sa'd ibn Abee Waqqaas said,

"I bear witness that the Prophet (sal-Allaahu 'alayhe wa sallam) said, 'There will come a tribulation during which one who sits will be better than one who stands, one who stands will be better than one who walks, and one who walks will be better than one who runs.' Someone asked, 'What do you advise if someone enters my house to kill me?' He said, 'Be like the son of Adam (i.e. resign yourself).'" [Muslim, Tirmidhee] [21]

Abu Moosaa al-Asharee said,

"The Prophet (sal-Allaahu 'alayhe wa sallam) said, 'Before the Hour comes, there will be a tribulation like patches of dark night. A man will get up a believer and go to sleep a kaafir, or will go to sleep a believer and

get up a kaafir. The one who sits will be better than one who stands, and one who walks will be better than one who runs. Break your bows, cut their strings, and strike your swords against stones. If someone comes to kill any of you, then be like the better of the two sons of Adam." [Abu Daawood] [22]

Abu Dharr said,

"The Prophet (sal-Allaahu 'alayhe wa sallam) was riding a donkey and sat me behind him. He said, 'O Abu Dharr, if the people were suffering from such severe hunger that you could not even get up from your bed to go to the mosque, what would you do?' I said, 'Allaah and His Messenger know best.' He said, 'Be decent and restrain yourself.' Then he said, 'O Abu Dharr, if the people were suffering from severe death (i.e. if a man were worth no more than a grave), what would you do? If the people were killing one another, until Hajar al-Zayt (an area of Madinah) were submerged in blood, what would you do?' I said, 'Allaah and His Messenger know best.' He said, 'Stay in your house and lock the door.' I asked, 'What if I am not left alone?' He said, 'Then be one of them.' I said, 'Should I take up my sword?' He said, 'If you did that, you would be joining them in their activities. No - if you fear that the brightness of the shining sword will disturb you, then cover your face with part of your clothing, and let him carry his own sin and your sin.'" [Ahmad] [23]

Abd Allaah ibn Amr said,

"We were on a journey with the Prophet (sal-Allaahu 'alayhe wa sallam)...When the Prophet (sal-Allaahu 'alayhe wa sallam)'s caller called for prayer, I went there. The Prophet (sal-Allaahu 'alayhe wa sallam) was addressing the people, saying: "O people, it has been the duty of every Prophet before me to guide his people to whatever he knew was good for them, and to warn them against whatever he knew was bad for them, but this Ummah has its time of peace and security at the beginning; at the end of its existence it will suffer trials and tribulations, one after the other. Tribulation will come, and the believer will say, "This will finish me", but it will pass. Another tribulation will come, and he will say, "This is it", but it will pass, and a third will come and go likewise. Whoever wishes to be rescued from Hell, and enter Paradise, let him die believing in Allaah and the Last Day, and treat the people as he himself wishes to be treated. If anyone gives allegiance to an Imaam, then let him obey him if he can (or on one occasion he said: as much as you can)."

Abd al-Rahman (one of the narrators of this Hadeeth) said,

"When I heard that, I put my head between my knees and said, 'But your cousin Mu'aawiyah is ordering us to squander our wealth among

ourselves in vanity, and to kill each other, although Allaah has said, "O you who believe! Squander not your wealth among yourselves in vanity..." [an-Nisaa (4):29]

Abd Allaah (another narrator) put his head in his hands and paused a while, then he raised his head and said,

"Obey him in that which is obedience to Allaah and disobey that which is disobedience to Allaah." I asked him, "Did you hear that from the Prophet (sal-Allaahu 'alayhe wa sallam)?" He said, "Yes, I heard it with my ears and understood it in my heart." [Ahmad, Abu Daawood, an-Nasaa'ee, Ibn Maajah] [24]

Abd Allaah ibn Amr said,

"I heard the Prophet (sal-Allaahu 'alayhe wa sallam) say, 'If you see my Ummah fearing a tyrant so much that they dare not tell him that he is a tyrant, then there will be no hope for them.'"

The Prophet (sal-Allaahu 'alayhe wa sallam) said,

"Among my Ummah, some will be swallowed up by the earth, some bombarded with stones, and some transformed into animals." [Ahmad] [25]

Footnotes

[1] Bukhaaree, Kitaab al-Fitan.

[2] Bukhaaree, Kitaab al-'Ilm.

[3] Bukhaaree, Kitaab al-Fitan, 9/60; Muslim, Baab Nuzuul al-Fitan ka-Mawaaqi' al-Qatar, 8/168.

[4] Bukhaaree, ibid.

[5] op. cit., 9/64; Muslim, Baab Nuzuul al-Fitan ka-Mawaaqi' al-Qatar.

[6] Bukhaaree, op. cit., 9/66.

[7] Bukhaaree, Kitaab Bid' al-Khalq, 4/150.

[8] Bukhaaree, Kitaab al-Fitan, 9/73.

[9] Bukhaaree, Kitaab al-Fitan, 8/132

Daws: a tribe in Yemen; Dhoo l-Khalasah: a house full of idols - it is so called because they believed that whoever worshipped it or went around it would be purified (khallasa). This Hadeeth means that the tribe of Daws will become apostates from Islaam and will go back to idol worshipping; even their women will exert themselves in worshipping the idol and running around it, so that their flesh will quiver.

[10] Bukhaaree, Kitaab al-Fitan, 9/73.

[11] Muslim, Kitaab al-Fitan wa Ashraat al-Saa'ah, 8/174.

[12] Bukhaaree, Kitaab al-Fitan, 9/74.

[13] Muslim, Kitaab al-Fitan wa Ashraat al-Saa'ah, 8/172.

[14] Muslim, Kitaab al-Jannah wa Sifat Na'imihaa wa Ahlihhaa, 8/155, 156.

[15] Muslim, ibid.

[16] Ibn Maajah narrated a similar Hadeeth in Kitaab al-Fitan (Hadeeth 4015), 2/1331. Ahmad, Musnad, 3/187.

Checker's Note: Da`eef due to the `an`anah (usage of the word `an (from)) of Makhool, Da`eef Ibn Maajah: 870.

[17] Ahmad, Musnad, 2/390.

Checker's Note: Saheeh. Weak isnaad but supported by other narrations similar in meaning. Musnad Imaam Ahmad, checking by Ahmad Shakir: 2/390.

[18] Ahmad, Musnad, 2/359.

Checker's Note: Saheeh, Silsilatul Ahadeeth as-Saheehah: 958. Wording should be "dislike of death".

[19] Ahmad, Musnad, 1/448.

Checker's Note: Saheeh. Musnad Imaam Ahmad, checking by Ahmad Shakir: [??] Ahmad's narration contains an unnamed narrator who is named in the narration of Abdur Razzaaq, no. 20727 and al-Hakim, 4/320, and he is reliable.

[20] Abu Daawood, ibid. (Hadeeth 4236). Muslim, Kitaab al-Fitan, 8/169.

Checker's Note: Saheeh, Saheeh Abee Daawood: 3580.

[21] Tirmidhee, Abwaab al-Fitan, (Hadeeth 2290), 6/436, 438. Ahmad, Musnad, 1/185.

Checker's Note: Saheeh, al-Irwa, no. 2451 of Shaykh al-Albaanee. It is saheeh but has not been reported by Muslim, as main text states.

[22] Abu Daawood, Abwaab al-Fitan wa'l-Malaahim, (Hadeeth 4139), 11/337.

Checker's Note: Saheeh, Abu Daawood and Ibn Maajah, Silsilatul Ahadeeth as-Saheehah: 1535.

[23] Ahmad, Musnad, 5/149; similar Hadeeth in Abu Daawood, Abwaab al-Fitan wa'l-Malaahim, (Hadeeth 4241), 11-340, 343.

Checker's Note: Saheeh, al-Irwa, no: 2451.

[24] Ahmad, Musnad, 5/149. Muslim, Kitaab al-Imaarah, 6-18. Ibn Maajah, Kitaab al-Fitan (Hadeeth 3956), 2/1306, 1037. an-Nasaa'ee, Kitaab al-Bay'ah (shorter version), 7-152, 153. Abu Daawood, Kitab al-Fitan (shorted version), Hadeeth 4429, 11-319.

Checker's Note: Saheeh, Silsilatul Ahadeeth as-Saheehah: 241.

[25] Ahmad, Musnad. 2/163.

Checker's Note: Da`eef, Silsilatul Ahaadeeth ad-Da`eefah: 1264. Its isnaad contains the `an`anah of Abu Zubair, but its last part ("Among my Ummah ...") is supported. See Silsilatul Ahadeeth as-Saheehah: 1787

The Signs and Portents of the Hour

'Abd Allaah ibn 'Amr said,

"I went to the Prophet (sal-Allaahu 'alayhe wa sallam) one day whilst he was performing Wudoo' (ablution) slowly and carefully. He raised his head, looked at me and said, 'Six things will happen to this Ummah: the death of your Prophet - 'and when I heard that I was aghast,' - this is the first. The second is that your wealth will increase so much that if a man were given ten thousand, he would still not be content with it. The third is that tribulation will enter the house of every one of you. The fourth is that sudden death will be widespread. The fifth is a peace-treaty between you and the Romans: they will gather troops against you for nine months - like a woman's period of childbearing - then they will be the first to break the treaty. The sixth is the conquest of a city.' I asked, 'O Messenger of Allaah, which city?' He said, 'Constantinople.' " [Ahmad] [1]

Abu Hurayrah said,

"The Prophet (sal-Allaahu 'alayhe wa sallam) said, 'Hasten to do good deeds before six things happen: the rising of the sun from the West, the smoke, the Dajjaal, the beast, the (death) of one of you, or general tribulation.' " [Ahmad, Muslim] [2]

Hudhayfah ibn 'Ubayd said,

"The Prophet (sal-Allaahu 'alayhe wa sallam) came upon us whilst, we were busy in discussion. He asked us, 'What are you talking about?' We said, 'We are discussing the Hour.' He said, 'It will not come until you see ten signs: the smoke, the Dajjaal, the beast, the sun rising from the West, the descent of Jesus son of Mary, Gog and Magog, and three land-slides - one in the East, one in the West, and one in Arabia, at the end of which fire will burst forth from the direction of Aden (Yemen) and drive people to the place of their final assembly.' " [Ahmad] [3]

Footnotes

[1] Ahmad, Musnad, 2/174.

Checker's Note: Da'eef, Musnad Imaam Ahmad, checking by Ahmad Shakir: 6623. Weak hadeeth due to Abra lamah al-Kalbi.

[2] Muslim, Kitaab al-Fitan, 8/207, Ahmad, Musnad, 2/337, 372.

[3] Muslim, Kitaab al-Fitan, 8/179.

Checker's Note: Wrong spelling, Ibn `Ubayd should be Ibn Usayd.

Reported by Muslim, not by Ahmad as main text states.

The Battle with the Romans

After the battle with the Romans, which ended with the conquest of Constantinople, the Dajjaal will appear, and Jesus son of Mary will

descend from Heaven to the earth, to the white minaret in the east of Damascus, at the time of Salaat al-Fajr (the morning prayer), as we shall see in the Saheeh Traditions.

Dhoo Mukhammar said,

"The Prophet (sal-Allaahu 'alayhe wa sallam) said, 'You will make a peace-treaty with the Romans, and together you will invade an enemy beyond Rome. You will be victorious and take much booty. Then you will camp in a hilly pasture; one of the Roman men will come and raise a cross and say "Victory to the Cross", so one of the Muslims will come and kill him. Then the Romans will break the treaty, and there will be a battle. They will gather an army against you and come against you with eighty banners, each banner followed by 10,000 men.' " [Ahmad, Abu Daawood, Ibn Maajah] [1]

Yusayr ibn Jaabir said,

"Once there was a red storm in Kufah. A man came who had nothing to say except, 'O 'Abd Allaah ibn Mas'ood, has the Hour come?' 'Abd Allaah was sitting reclining against something, and said, 'The Hour will not come until people will not divide inheritance, nor rejoice over booty.' Pointing towards Syria, he said, 'An enemy will gather forces against the Muslims and the Muslims will gather forces against them.' I asked, 'Do you mean the Romans?' He said, 'Yes. At that time there will be very heavy fighting. The Muslims will prepare a detachment to fight to the death; they will not return unless they are victorious. They will fight until night intervenes. Both sides will return without being victorious; then many will be killed on both sides. On the fourth day, the Muslims who are left will return to the fight, and Allaah will cause the enemy to be routed. There will be a battle the like of which has never been seen, so that even if a bird were to pass their ranks, it would fall down dead before it reached the end of them. Out of a family of one hundred, only one man will survive, so how could he enjoy the booty or divide any inheritance? While they are in this state, they will hear of an even worse calamity. A cry will reach them: "The Dajjaal has taken your place among your offspring." So they will throw away whatever is in their hands and go forward, sending 10 horsemen as a scouting party. The Prophet (sal-Allaahu 'alayhe wa sallam) said, 'I know their names, and the names of their fathers, and the colours of their horses. They will be the best horsemen on the face of the earth on that day.' " [Ahmad, Muslim] [2]

Abu Hurayrah said,

"The Prophet (sal-Allaahu 'alayhe wa sallam) said, 'The Hour will not come until the Romans camp at al-A'mash or Dabeeq. An army,

composed of the best people on earth at that time, will come out from Madinah to meet them. When they have arranged themselves in ranks, the Romans will say, 'Do not stand between us and those who took prisoners from amongst us. Let us fight with them.' The Muslims will say, 'No, by Allaah, we will never stand aside from you and our brothers.' Then they will fight. One-third will runaway, and Allaah will never forgive them. One-third will be killed, and they will be the best of martyrs in Allaah's sight. One-third, who will never be subjected to trials or tribulations, will win, and will conquer Constantinople. Whilst they are sharing out the booty, after hanging their swords on the olive-trees, Satan will shout to them that the Dajjaal has taken their place among their families. When they come to Syria, the Dajjaal will appear, while they are preparing for battle and drawing up the ranks. When the time for prayer comes, Jesus the son of Mary will descend and lead them in prayer. When the enemy of Allaah (i.e. the Dajjaal) sees him, he will start to dissolve like salt in water, but Allaah will kill him.' " [Muslim] [3]

The Prophet (sal-Allaahu 'alayhe wa sallam) said,

"The Hour will not come until the furthest border of the Muslims will be in Bulaa." Then he said, "O 'Alee!" 'Alee said, "May my father and mother be sacrificed for you!" The Prophet (sal-Allaahu 'alayhe wa sallam) said, "You will fight the Romans, and those who come after you will fight them, until the best people among the Muslims, the people of al-Hijaz, will go out to fight them, fearing nothing but Allaah. They will conquer Constantinople with Tasbeeh and Takbeer (saying "Subhaan Allaah" and "Allaahu Akbar"), and they will obtain booty the like of which has never been seen - they will share it out by scooping it up with their shields. Someone will come and say, 'The Dajjaal has appeared in your land', but he will be lying. Anyone who takes notice of him will regret it, and anyone who ignores him will regret it." [Ibn Maajah] [4]

Naafi' ibn 'Utbah said,

"The Prophet (sal-Allaahu 'alayhe wa sallam) said, 'You will attack Arabia, and Allaah will enable you to conquer it. Then you will attack Persia, and Allaah will enable you to conquer it. Then you will attack Rome, and Allaah will enable you to conquer it. Then you will attack the Dajjaal, and Allaah will enable you to conquer him.' " [Muslim] [5]

When Mustawrid al-Qurashee was sitting with 'Amr ibn al-'Aas, he said, "I heard the Prophet (sal-Allaahu 'alayhe wa sallam) say, 'The Hour will come when the Romans will be in the majority.' 'Amr asked him, "What are you saying?" He said, "I am repeating that which I heard from the Prophet (sal-Allaahu 'alayhe wa sallam)." 'Amr said, "If you say this, it is

true, because they have four good characteristics: they are the most able to cope with tribulation, the quickest to recover after disaster and to return to the fight after disaster, and are the best as far as treating the poor, weak and orphans is concerned. They have a fifth characteristic which is very good; they do not allow themselves to be oppressed by their kings." [6]

The Prophet (sal-Allaahu 'alayhe wa sallam) said,

"You will fight the Romans, and Believers from the Hijaaz will fight them after you, until Allaah enables them to conquer Constantinople and Rome with Tasbeeh and Takbeer ("Subhaan Allaah" and "Allaahu Akbar"). Its fortifications will collapse, and they will obtain booty the like of which has never been seen, so that they will share it out by scooping it up with their shields. Then someone will cry, 'O Muslims! The Dajjaal is in your country, with your families', and the people will leave the wealth. Anyone who takes notice will regret it and anyone who ignores it will regret it. They will ask, 'Who shouted?' but they will not know who he is. They will say, 'Send a vanguard to Ilyaa.' If the Dajjaal has appeared, you will hear about his deeds.' So they will go and see, and if they see that everything is normal, they will say, 'No-one would give a shout like that for no reason, so let us go together to Ilyaa.' If we find the Dajjaal there we will fight him together, until Allaah decides between us and him. If we do not find the Dajjaal, we will go back to our country and our families.' " [7]

Mu'aadh ibn Jabal said,

"The Prophet (sal-Allaahu 'alayhe wa sallam) said, 'The building of Bayt al-Maqdis (in Jerusalem) will be followed by the destruction of Yathrib (Madeenah), which will be followed by the conquest of Constantinople, which will be followed by the appearance of the Dajjaal.' Then he put his hand on the thigh or the shoulder of the one with whom he was speaking (i.e. Mu'aadh), and said, 'This is as true as the fact that you are here (or as true as you are sitting here).' " [8]

This does not mean that Madeenah will be destroyed completely before the appearance of the Day, but that will happen at the end of time, as we shall see in some authentic Ahaadeeth. But the building of Bayt al-Maqdis will be the cause of the destruction of Madeenah, as it was proven in the Hadeeth that the Dajjaal will not be able to enter Madinah. He will be prevented from doing so because it is surrounded by angles bearing unsheathed swords. [9]

Abu Hurayrah said,

"The Prophet (sal-Allaahu 'alayhe wa sallam) said about Madeenah: 'Neither plague nor the Dajjaal can enter it.' " [Bukhaaree] [10]

Footnotes

[1] Similar Hadeeth in Abu Daawood, Kitaab al-Malaahim, (Hadeeth 4271), 11/397/399. Ibn Maajah, Kitab al-Fitan (Hadeeth 4089), 2/1369. Ahmad, Musnad, 9104.

Checker's Note: Saheeh, Saheeh al-Jami as-Sagheer: 3612.

[2] Muslim, Kitaab al-Fitan, 8/177, 178. Ahmad, Musnad, 1/384, 385.

[3] Muslim, Kitaab al-Fitan, 8 - 175, 176.

Al-A'mash is a place outside the city, and Dabeeq is a market-place in the city. "The city" refers to Aleppo (some say Damascus).

[4] Ibn Maajah, Kitaab al-Fitan (Hadeeth 4094), 2 - 1370.

The one who believes the liar will regret it, because he will find that the Dajjaal is not there. The one who does not believe him will regret it because the Dajjaal will appear soon afterwards.

Checker's Note: Fabricated. The reason is Kathir ibn `Abdillah, who is declared a liar by Abu Daawood and Shaafi'ee. He narrates a fabricated collection of hadeeth.

[5] Muslim, Kitaab al-Fitan wa Ashtaar al-Saa'ah, 8 - 178. Ibn Maajah, Baab al-Malaahim (Hadeeth 4091), 2 - 1380.

[6] Muslim, Kitaab al-Fitaan, 8 - 176.

[7] Al-Haythamee, Majma' al-Zawaa'id. Ibn Maajah, 7:248.

Checker's Note: Fabricated. Same reasons as the previous one.

Reported by al-Bazzar, Kashful Astar bi Zawa'id al-Bazzar of al-Haythamee: 3386.

[8] Hasan, al-Mishkat, 1st checking: 5424.

[9] Abu Daawood, Kitaab al-Malaahim (Hadeeth 4273), 11 - 400, 401; Ahmad, Musnad, 5/245.

Checker's Note: Hasan.

[10] Bukhaaree, Kitaab al-Fitan, 9/76.

The Appearance of the Dajjaal

First of all, we will quote the reports which mention the liars and "dajjaals" who will precede the coming of the Dajjaal, or Antichrist, who will be the last of them; may Allaah curse them and punish them with Hell-fire.

Jaabir ibn Samurah said,

"I heard the Prophet (sal-Allaahu 'alayhe wa sallam) say, 'Just before the Hour there will be many liars.' " Jaabir said, "Be on your guard against them." [Muslim] [1]

Jaabir said,

"I heard the Prophet (sal-Allaahu 'alayhe wa sallam) say, 'Just before the Hour there will be many liars; among them is the one in al-Yamamah, the

'Ansi in San'a', the one in Himyar, and the Dajjaal. This will be the greatest fitnah.' " [Ahmad] [2]

Abu Hurayrah said,

"The Prophet (sal-Allaahu 'alayhe wa sallam) said, 'The Hour will not come ... until nearly 30 "dajjaals" (liars) appear, each one claiming to be a messenger from Allaah.' " [Bukhaaree and Muslim] [3]

Abu Hurayrah said,

"The Prophet (sal-Allaahu 'alayhe wa sallam) said, 'The Hour will not come until 30 "dajjaals" appear, each of them claiming to be a messenger from Allaah, wealth increases, tribulations appear and al-Harj increases.' Someone asked, 'What is al-Harj?' He said, 'Killing, killing.' " [Ahmad] [4]

Abu Hurayrah said,

"The Prophet (sal-Allaahu 'alayhe wa sallam) said, 'The Hour will not come until 30 "dajjaals" appear, all of them lying about Allaah and His Messenger.' " [Abu Daawood] [5]

Abu Hurayrah said,

"The Prophet (sal-Allaahu 'alayhe wa sallam) said, 'Just before the Hour, there will be thirty "dajjaals", each of whom will say, I am a Prophet.' " [Ahmad] [6]

Abu Hurayrah said,

"The Prophet (sal-Allaahu 'alayhe wa sallam) said, 'There will be "dajjaals" and liars among my Ummah. They will tell you something new, which neither you nor your forefathers have heard. Be on your guard against them, and do not let them lead you astray.' " [Ahmad] [7]

Thawbaan said,

"The Prophet (sal-Allaahu 'alayhe wa sallam) said, 'There will be thirty liars among my Ummah. Each one will claim that he is a prophet; but I am the last of the Prophets (Seal of the Prophets), and there will be no Prophet after me.' " [Ahmad] [8]

The Prophet (sal-Allaahu 'alayhe wa sallam) said,

"Verily before the Day of Resurrection there will appear the Dajjaal, and thirty or more liars." [Ahmad] [9]

Ibn 'Umar said,

"I heard the Prophet (sal-Allaahu 'alayhe wa sallam) say, 'Among my Ummah there will be more than seventy callers, each of whom will be calling people to Hell-fire. If I wished, I could tell you their names and tribes.' " [10]

Abu Bakrah said,

"The people spoke a great deal against Musaylimah before the Prophet

(sal-Allaahu 'alayhe wa sallam) said anything about him. Then the Prophet (sal-Allaahu 'alayhe wa sallam) got up to give a speech and said: '...as for this man about whom you have spoken so much - he is one of the thirty liars who will appear before the Hour, and there is no town which will not feel the fear of the Antichrist.' " [Ahmad] [11]

In another version of this report, the Prophet (sal-Allaahu 'alayhe wa sallam) said,

"He is one of the thirty liars who will appear before the Dajjaal. There is no town which will escape the fear of the Dajjaal, apart from Madeenah. At that time there will be two angels at every entrance of Madeenah, warding off the fear of the Antichrist." [12]

Anas ibn Malik said,

"The Prophet (sal-Allaahu 'alayhe wa sallam) said, 'The time of the Dajjaal will be years of confusion. People will believe a liar, and disbelieve one who tells the truth. People will distrust one who is trustworthy, and trust one who is treacherous; and the Ruwaybidah will have a say.' Someone asked, 'Who are the Ruwaybidah?' He said, 'Those who rebel against Allaah and will have a say in general affairs.' " [Ahmad] [13]

Footnotes

[1] Muslim, Kitaab al-Fitan, 8/189.

[2] Ahmad, Musnad, 3/345.

Checker's Note: Ahmad's isnaad contains Ibn Lahi'ah who reports by way of `an, as does Abu Zubair. Al-Bazzar's isnaad contains `Abdur-Rahman ibn Maghra and Mujaahid ibn Sa`eed. Majma' az-Zawaid of al-Haythamee: 7/335. The status of the hadeeth is unknown as no muhaddith, as far as we know, has given a definite verdict.

[3] See Part 7, where the Hadeeth is quoted in full.

[4] Ahmad, Musnad, 2 - 457.

Checker's Note: Saheeh.

[5] Ahmad, Musnad, 2/450.

Checker's Note: Hasan, Saheeh Abee Daawood: 3643.

[6] Ahmad, Musnad, 2/429.

Checker's Note: Saheeh, Silsilatul Ahadeeth as-Saheehah: 1683.

[7] Ahmad, Musnad, 20/349.

Checker's Note: Da`eef isnaad, but Muslim reports similar wording.

[8] Ahmad, Musnad, 5/46.

Checker's Note: Saheeh. Wrong reference, Ahmad, Musnad, 5/46, should be Ahmad, Musnad, 5/278.

[9] Ahmad, Musnad, 2/95.

Checker's Note: Hasan, Silsilatul Ahadeeth as-Saheehah: 1683, Musnad Imaam Ahmad, checking by Ahmad Shakir: 5694.

[10] Da'eef. Reported by Abu Ya'la. Its isnaad contains Laith ibn Abee Sulaim.

[11] Ahmad, Musnad, 5/41, 46.

Checker's Note: Saheeh, Majma' az-Zawaid of al-Haythamee: 7/335.

[12] Ahmad, Musnad, 5/46.

Checker's Note: Saheeh, Musnad Imaam Ahmad, checking by Ahmad Shakir: 5/41. It is part of no. 10 above, which is not given in full in the book.

[13] Ahmad, Musnad, 3/220.

Checker's Note: Saheeh. Its isnaad is hasan and is further supported, Silsilatul Ahadeeth as-Saheehah: 1887, Kashful Astar bi Zawa'id al-Bazzar of al-Haythamee: 3373.

Ahaadeeth about the Dajjaal

'Abd Allaah ibn 'Umar said,

"Umar ibn al-Khattab went along with the Prophet (sal-Allaahu 'alayhe wa sallam) and a group of people to Ibn Sayyaad, and found him playing with some children near the battlement of Banoo Maghaalah. At that time Ibn Sayyaad was on the threshold of adolescence; he did not realise that anybody was near until the Prophet (sal-Allaahu 'alayhe wa sallam) struck him on the back. The Prophet (sal-Allaahu 'alayhe wa sallam) said to him: 'Do you bear witness than I am the Messenger of Allaah?' Ibn Sayyaad looked at him and said, 'I bear witness that you are the Prophet (sal-Allaahu 'alayhe wa sallam) of the unlettered.' Then Ibn Sayyaad said to the Prophet (sal-Allaahu 'alayhe wa sallam), 'Do you bear witness that I am the Messenger of Allaah?' The Prophet (sal-Allaahu 'alayhe wa sallam) dismissed this and said, 'I believe in Allaah and His Messengers.' Then the Prophet (sal-Allaahu 'alayhe wa sallam) asked him, 'What do you see?' Ibn Sayyaad said, 'Sometimes a truthful person comes to me, and sometimes a liar.' The Prophet (sal-Allaahu 'alayhe wa sallam) said to him, 'You are confused', then he said, 'I am hiding something from you.' Ibn Sayyaad said, 'It is Dukh.' The Prophet (sal-Allaahu 'alayhe wa sallam) said, 'Silence! You will not be able to go beyond your rank.' 'Umar ibn al-Khattab said, 'O Messenger of Allaah, shall I cut off his head?' The Prophet (sal-Allaahu 'alayhe wa sallam) said, 'If he is (the Dajjaal) you will not be able to overpower him, and if he is not, then killing will not do you any good.' "

Saleem ibn 'Abd Allaah said,

"I heard 'Abd Allaah ibn 'Umar say, 'After that, the Prophet (sal-Allaahu 'alayhe wa sallam) and Ubayy ibn Ka'b went along to the palm trees where Ibn Sayyaad was. The Prophet (sal-Allaahu 'alayhe wa sallam) started to hide behind a tree, with the intention of hearing something from Ibn Sayyaad before Ibn Sayyaad saw him. The Prophet (sal-Allaahu 'alayhe wa sallam) saw him lying on a bed, murmuring beneath a blanket. Ibn Sayyaad's mother saw the Prophet (sal-Allaahu 'alayhe wa sallam) hiding behind a tree, and said to her son, "O Saf (Ibn Sayyaad's first name), here is Muhammad!" Ibn Sayyad jumped up, and the Prophet (sal-Allaahu 'alayhe wa sallam) said, "If you had left him alone, he would have explained himself." "

Saleem said,

"Abd Allaah ibn'Umar said, The Prophet (sal-Allaahu 'alayhe wa sallam) stood up to address the people. He praised Allaah as He deserved to be praised, then he spoke about the Dajjaal: 'I warn you against him; there is no Prophet who has not warned his people against him, even Noah warned his people against him. But I will tell you something which no other Prophet has told his people. You must know that the Dajjaal is one-eyed, and Allaah is not one-eyed.' "

Ibn Shihaab said:

"Umar ibn Thaabit al-Ansaaree told me that some of the Companions of the Prophet (sal-Allaahu 'alayhe wa sallam) told him that on the day when he warned the people about the Dajjaal, the Prophet (sal-Allaahu 'alayhe wa sallam) said: 'There will be written between his eyes the word Kaafir (unbeliever). Everyone who resents his bad deeds - or every believer - will be able to read it.' He also said, 'You must know that no one of you will be able to see his Lord until he dies.' " [Muslim, Bukhaaree] [1]

Ibn 'Umar said,

"The Prophet (sal-Allaahu 'alayhe wa sallam) mentioned the Dajjaal to the people. He said, 'Allaah is not one-eyed, but the Dajjaal is blind in his right eye, and his eye is like a floating grape.' " [Muslim] [2]

Anas ibn Malik said,

"The Prophet (sal-Allaahu 'alayhe wa sallam) said, 'There has never been a Prophet who did not warn his people against that one-eyed liar. Verily he is one-eyed and your Lord is not one-eyed. On his forehead will be written the letter Kaf, Fa, Ra (Kaafir).' " [Muslim, Bukhaaree] [3]

Hudhayfah said,

"The Prophet (sal-Allaahu 'alayhe wa sallam) said, 'I know more about the powers which the Dajjaal will have than he will know himself. He will have two flowing rivers: one will appear to be pure water, and the other

will appear to be flaming fire. Whosoever lives to see that, let him choose the river which seems to be fire, then let him close his eyes, lower his head and drink from it, for it will be cold water. The Dajjaal will be one-eyed; the place where one eye should be will be covered by a piece of skin. On his forehead will be written the word Kaafir, and every believer, whether literate or illiterate, will be able to read it.' " [Muslim] [4]

Abu Hurayrah said,

"The Prophet (sal-Allaahu 'alayhe wa sallam) said, 'Shall I tell you something about the Dajjaal which no Prophet has ever told his people before me? The Dajjaal is one-eyed and will bring with him something which will resemble Paradise and Hell; but that which he calls Paradise will in fact be Hell. I warn you against him as Noah warned his people against him.' " [Bukhaaree, Muslim] [5]

Muhammad ibn Munkadir said:

"I saw Jaabir ibn 'Abd Allaah swearing by Allaah that Ibn Sayyaad was the Dajjaal, so I asked him, 'Do you swear by Allaah?' He said, 'I heard 'Umar swear to that effect in the presence of the Prophet (sal-Allaahu 'alayhe wa sallam), and the Prophet (sal-Allaahu 'alayhe wa sallam) did not disapprove of it.' " [6]

Some 'ulamaa' (scholars) say that some of the Sahaabah (Companions of the Prophet) believed Ibn Sayyaad to be the greater Dajjaal, but that is not the case: Ibn Sayyaad was a lesser dajjal.

Ibn Sayyaad travelled between Makkah and Madeenah with Abu Sa'eed, and complained to him about the way that people were saying that he was the Dajjaal. Then he said to Abu Sa'eed,

"Did not the Prophet (sal-Allaahu 'alayhe wa sallam) say that the Dajjaal would not enter Madinah? I was born there. Did not he say that he would not have any children? - I have children. Did not he say that he would be a Kaafir? - I have embraced Islaam. Of all the people, I know the most about him: I know where he is now. If I were given the opportunity to be in his place, I would not resent it.' " [Bukhaaree, Muslim]

There are many Ahaadeeth about Ibn Sayyaad, some of which are not clear as to whether he was the Dajjaal or not. We shall see Ahaadeeth which indicates that the Dajjaal is not Ibn Sayyaad, as in the Hadeeth of Faatimah Bint Qays al-Fahriyyah, although this does not mean that he was not one of the lesser Dajjaal; but Allaah knows best.

Footnotes

[1] Bukhaaree, Kitaab al-Adab, 8/49, 50. Muslim, Kitaab al-Fitan, 8/192, 193.

Ibn Sayyaad's [or Ibn Sa'eed's] first name was Saaf. He had some characteristics similar to those ascribed to the Dajjaal. When he was young, he was like a Kaahin (soothsayer) - sometimes he spoke the truth, sometimes he lied. When he grew up, he embraced Islaam and displayed some good characteristics, but later he changed, and it was said that his behaviour might indicate that he was the Dajjaal. But the Prophet (sal-Allaahu 'alayhe wa sallam) had not received any Wahy (revelation) to that effect, so he told 'Umar: "If he is [the Dajjaal] you will not be able to overpower him."

Banoo Maghaalah: if you stand facing the Masjid al-Nabawee, (the Prophet's Mosque in Madeenah), everything on your right is the territory of Banoo Maghaalah.

Dukh: i.e. al-Dukhaan (smoke). The Prophet (sal-Allaahu 'alayhe wa sallam) was thinking of the Aayah,

"Then wait you for the Day when the sky will bring forth a visible smoke."

[ad-Dukhaan (44):10]

"... with the intention of hearing something..." in other words, the Prophet (sal-Allaahu 'alayhe wa sallam) wanted to eavesdrop on Ibn Sayyaad so that he and his companions could find out whether he was a soothsayer (kaahin) or a sorcerer.

"if you had left him alone, he would have had explained himself": i.e., if his mother had not told him that the Prophet (sal-Allaahu 'alayhe wa sallam) was there, then the Prophet (sal-Allaahu 'alayhe wa sallam) would have found out what he was - a soothsayer or a sorcerer.

[2] Muslim, Kitaab al-Fitan, 8/194, 195.

"His eye is like a floating grape" - this means that, his eye will protrude and there will be some kind of brightness in it.

[3] Muslim, ibid. Bukhaaree, Kitaab al-Fitan, 9/75, 76.

"On his forehead will be written the letters Kaaf, Faa', Raa' " - this indicates that he will call people to Kufr, not the right path, so we must avoid him. The fact that Muslims will be able to identify him as a Kaafir is a great blessing from Allaah to this Ummah.

[4] Muslim, ibid. Shorter version in Bukhaaree, Kitaab al-Fitan, 9/75.

[5] Bukhaaree, Kitaab al-Anbiyaa, 4/75. Muslim, Kitaab al-Fitan, 8/196.

[6] Muslim, Kitaab al-Fitan, 8/192.

The Hadeeth of Faatimah bint Qays

'Aamir ibn Sharaaheel Sha'bi Sha'b Hamdaan reported that he asked Faatimah bint Qays, the sister of Dahhaak ibn Qays, who was one of the first Muhaajiraat,

"Tell me a Hadeeth which you heard directly from the Prophet (sal-

Allaahu 'alayhe wa sallam) with no narrator in between." She said, "I can tell you if you like." He said, "Yes, please tell me." She said, "I married Ibn al-Mugheerah, who was one of the best of the youth of Quraysh in those days. But he fell in the first Jihaad on the side of the Prophet (sal-Allaahu 'alayhe wa sallam).

"When I became a widow, 'Abd al-Rahmaan ibn 'Awf, one of the companions of the Prophet (sal-Allaahu 'alayhe wa sallam) sent me a proposal of marriage. The Prophet (sal-Allaahu 'alayhe wa sallam) also sent me a proposal of marriage on behalf of his freedman Usaamah ibn Zayd. I had been told that the Prophet (sal-Allaahu 'alayhe wa sallam) had said, 'He who loves me should also love Usaamah.' When the Prophet (sal-Allaahu 'alayhe wa sallam) spoke to me, I said, 'It is up to you: marry me to whomever you wish.'

"The Prophet (sal-Allaahu 'alayhe wa sallam) said, 'Go and stay with Umm Shareek.' Umm Shareek was a rich Ansaaree (Muslim originally from Madeenah) woman, who spent much in the way of Allaah and entertained many guests. I said, 'I will do as you wish.' Then he said, 'Don't go. Umm Shareek has many guests, and I would not like it if your head or leg were to become uncovered accidentally and people saw something you would not wish them to see. It is better if you go and stay with your cousin 'Abd Allaah ibn 'Amr ibn Umm Maktoom' (Abd Allaah was of the Banoo Fihr of Quraysh, the same tribe as that to which Faatimah belonged).

"So I went to stay with him, and when I had completed my 'Iddah (period of waiting), I heard the Prophet's (sal-Allaahu 'alayhe wa sallam) announcer calling for congregational prayer. I went out to the mosque, and prayed behind the Prophet (sal-Allaahu 'alayhe wa sallam). I was in the women's row, which was at the back of the congregation. When the Prophet (sal-Allaahu 'alayhe wa sallam) had finished his prayer, he sat on the pulpit, smiling, and said, 'Everyone should stay in his place.' Then he said, 'Do you know why I had asked you to assemble?' The people said, 'Allaah and His Messenger know best.'

"He said, 'By Allaah, I have not gathered you here to give you an exhortation or a warning. I have kept you here because Tameem ad-Daaree, a Christian man who has come and embraced Islaam, told me something which agrees with that which I have told you about the Dajjaal. He told me that he had sailed in a ship with thirty men from Banoo Lakhm and Banoo Judhaam. The waves had tossed them about for a month, then they were brought near to an island, at the time of sunset. They landed on the island, and were met by a beast who was so hairy that they

could not tell its front from its back. They said, "Woe to you! What are you?" It said, "I am al-Jassaasah." They said, "What is al-Jassaasah?" It said, "O people, go to this man in the monastery, for he is very eager to know about you." Tameem said that when it named a person to us, we were afraid lest it be a devil.

"Tamim said, 'We quickly went to the monastery. There we found a huge man with his hands tied up to his neck and with iron shackles between his legs up to the ankles. We said, "Woe to you, who are you?" He said, "You will soon know about me. Tell me who you are." We said, "We are people from Arabia. We sailed in a ship, but the waves have been tossing us about for a month, and they brought us to your island, where we met a beast who was so hairy that we could not tell its front from its back. We said to it, "Woe to you! What are you?" and it said, "I am al-Jassaasah." We asked, "What is al-Jassaasah?" and it told us, "Go to this man in the monastery, for he is very eager to know about you." So we came to you quickly, fearing that it might be a devil.'

"The man said, 'Tell me about the date-palms of Baysaan.' We said, 'What do you want to know about them?' He said, 'I want to know whether these trees bear fruit or not.' We said, 'Yes.' He said, 'Soon they will not bear fruit.' Then he said, 'Tell me about the lake of at-Tabariyyah [Tiberias, in Palestine].' We said, 'What do you want to know about it?' He asked, 'Is there water in it?' We said, 'There is plenty of water in it.' He said, 'Soon it will become dry.' Then he said, 'Tell me about the spring of Zughar.' We said, 'What do you want to know about it?' He said, 'Is there water in it, and does it irrigate the land?' We said, 'Yes, there is plenty of water in it, and the people use it to irrigate the land.'

"Then he said, 'Tell me about the unlettered Prophet - what has he done?' We said, 'He has left Makkah and settled in Yathrib.' He asked, 'Do the Arabs fight against him?' We said, 'Yes.' He said, 'How does he deal with them?' So we told him that the Prophet (sal-Allaahu 'alayhe wa sallam) had overcome the Arabs around him and that they had followed him. He asked, 'Has it really happened?' We said, 'Yes.' He said, 'It is better for them if they follow him. Now I will tell you about myself. I am the Dajjal. I will soon be permitted to leave this place: I will emerge and travel about the earth. In forty nights I will pass through every town, except Makkah and Madeenah, for these have been forbidden to me. Every time I try to enter either of them, I will be met by an angel bearing an unsheathed sword, who will prevent me from entering. There will be angels guarding them at every passage leading to them.'

Faatimah said, "The Prophet (sal-Allaahu 'alayhe wa sallam), striking the

pulpit with his staff, said: 'This is Tayyibah, this is Tayyibah, this is Tayyibah, [i.e. Madeenah]. Have I not told you something like this?' The people said, 'Yes.' He said, 'I liked the account given to me by Tameem because it agrees with that which I have told you about the Dajjaal, and about Makkah and Madeenah. Indeed he is in the Syrian sea or the Yemen sea. No, on the contrary, he is in the East, he is in the East, he is in the East' and he pointed towards the East. Faatimah said: I memorised this from the Prophet (sal-Allaahu 'alayhe wa sallam)." [Muslim] [1]

'Abd Allaah ibn 'Umar said,

"The Prophet (sal-Allaahu 'alayhe wa sallam) said, 'While I was asleep, I saw myself in a dream performing Tawaaf (circumambulation) around the Ka'bah. I saw a ruddy man with lank hair and water dripping from his head. I said, "Who is he?" and they said, "The son of Mary." Then I turned around and saw another man with a huge body, red complexion, curly hair and one eye. His other eye looked like a floating grape. They said, "This is the Dajjaal." The one who most resembles him is Ibn Qatan, a man from the tribe of al-Khuzaa'ah.' " [Bukhaaree, Muslim] [2]

Jaabir ibn 'Abd Allaah said,

"The Prophet (sal-Allaahu 'alayhe wa sallam) said, 'The Dajjaal will appear at the end of time, when religion is taken lightly. He will have forty days in which to travel throughout the earth. One of these days will be like a year, another will be like a month, a third will be like a week, and the rest will be like normal days. He will be riding a donkey; the width between its ears will be forty cubits. He will say to the people: "I am your lord." He is one-eyed, but your Lord is not one-eyed. On his forehead will be written the word Kaafir, and every believer, literate or illiterate, will be able to read it. He will go everywhere except Makkah and Madeenah, which Allaah has forbidden to him; angels stand at their gates. He will have a mountain of bread, and the people will face hardship, except for those who follow him. He will have two rivers, and I know what is in them. He will call one Paradise and one Hell. Whoever enters the one he calls Paradise will find that it is Hell, and whoever enters the one he calls Hell will find that it is Paradise. Allaah will send with him devils who will speak to the people. He will bring a great tribulation; he will issue a command to the sky and it will seem to the people as if it is raining. Then he will appear to kill someone and bring him back to life. After that he will no longer have this power. The people will say, "Can anybody do something like this except the Lord?" The Muslims will flee to Jabal al-Dukhaan in Syria, and the Dajjaal will come and besiege them. The siege will intensify and they will suffer great hardship. Then Jesus son of Mary will

descend, and will call the people at dawn: "O people, what prevented you from coming out to fight this evil liar?" They will answer, "He is a Jinn." Then they will go out, and find Jesus son of Mary. The time for prayer will come, and the Muslims will call on Jesus to lead the prayer, but he will say, "Let your Imaam lead the prayer." Their Imaam will lead them in praying Salaat al-Subh (Morning prayer), then they will go out to fight the Dajjaal. When the liar sees Jesus, he will dissolve like salt in water. Jesus will go to him and kill him, and he will not let anyone who followed him live.' " [Ahmad] [3]

Footnotes

[1] Muslim, Kitaab al- Fitan, 8/203-205.

Al-Jassaasah is so called because he spies on behalf of the Dajjaal (from jassa - to try to gain information, to spy out, etc.).

Baysaan - a village in Palestine.

'Ayn Zughar (the spring of Zughar) is a town in Palestine.

[2] Bukhaaree, Kitaab al-Fitan, 9/75. Muslim, Kitaab al-Imaan, 1/108.

[3] Ahmad, Musnad, 3/367, 368.

Checker's Note: Da`eef. Silsilatul Ahaadieeh ad-Da`eefah: 1969. It contains the `an`anah of Abu Zubair. Parts are found in authentic narrations. Refer to Dajjaal section in Saheeh Muslim.

The Hadeeth of Al-Nuwas Ibn Sam'an Al-Kilabi

Al-Nuwas ibn Saman said,

"One morning the Prophet (sal-Allaahu 'alayhe wa sallam) spoke about the Dajjaal. Sometimes he described him as insignificant, and sometimes he described him as so dangerous that we thought he was in the clump of date-palms nearby. When we went to him later on, he noticed that fear in our faces, and asked, 'What is the matter with you?' We said, 'O Messenger of Allaah, this morning you spoke of the Dajjaal; sometimes you described him as insignificant, and sometimes you described him as being so dangerous that we thought he was in the clump of date-palms nearby.

"The Prophet (sal-Allaahu 'alayhe wa sallam) said, 'I fear for you in other matters besides the Dajjaal. If he appears whilst I am among you, I will contend with him on your behalf. But if he appears while I am not among you, then each man must contend with him on his own behalf, and Allaah will take care of every Muslim on my behalf. The Dajjaal will be a young man, with short, curly hair, and one eye floating. I would liken him to 'Abd al-Uzzaa ibn Qatan. Whoever amongst you lives to see him should recite the opening Ayaat of Surat al-Kahf. He will appear on the way between

Syria and Iraq, and will create disaster left and right. O servants of Allaah, adhere to the Path of Truth.' "

"We said, 'O Messenger of Allaah, for the day which is like a year, will one days prayers be sufficient?' He said, 'No, you must make an estimate of the time, and then observe the prayers.' "

"We asked, 'O Messenger of Allaah, how quickly will he walk upon the earth?' He said, 'Like a cloud driven by the wind. He will come to the people and call them (to a false religion), and they will believe in him and respond to him. He will issue a command to the sky, and it will rain; and to the earth, and it will produce crops. After grazing on these crops, their animals will return with their udders full of milk and their flanks stretched. Then he will come to another people and will call them (to a false religion), but they will reject his call. He will depart from them; they will suffer famine and will possess nothing in the form of wealth. Then he will pass through the wasteland and will say, Bring forth your treasures, and the treasures will come forth, like swarms of bees. Then he will call a man brimming with youth; he will strike him with a sword and cut him in two, then place the two pieces at the distance between an archer and his target. Then he will call him, and the young man will come running and laughing.' "

"At that point, Allaah will send the Messiah, son of Mary, and he will descend to the white minaret in the east of Damascus, wearing two garments dyed with saffron, placing his hands on the wings of two angels. When he lowers his head, beads of perspiration will fall from it, and when he raises his head, beads like pearls will scatter from it. Every Kaafir who smells his fragrance will die, and his breath will reach as far as he can see. He will search for the Dajjaal until he finds him at the gate of Ludd, where he will kill him."

"Then a people whom Allaah has protected will come to Jesus son of Mary, and he will wipe their faces (i.e. wipe the traces of hardship from their faces) and tell them of their status in Paradise. At that time Allaah will reveal to Jesus: "I have brought forth some of My servants whom no-one will be able to fight. Take My servants safely to at-Toor."

"Then Allaah will send Gog and Magog, and they will swarm down from every slope. The first of them will pass by the Lake of Tiberias, and will drink some of its water; the last of them will pass by it and say, "There used to be water here." Jesus, the Prophet of Allaah, and his Companions will be besieged until a bull's head will be dearer to them than one hundred dinars are to you nowadays."

"Then Jesus and his Companions will pray to Allaah, and He will send

insects who will bite the people of Gog and Magog on their necks, so that in the morning they will all perish as one. Then Jesus and his Companions will come down and will not find any nook or cranny on earth which is free from their putrid stench. Jesus and his Companions will again pray to Allaah, Who will send birds like the necks of camels; they will seize the bodies of Gog and Magog and throw them wherever Allaah wills. Then Allaah will send rain which no house or tent will be able to keep out, and the earth will be cleansed, until it will look like a mirror. Then the earth will be told to bring forth its fruit and restore its blessing. On that day, a group of people will be able to eat from a single pomegranate and seek shelter under its skin (i.e. the fruit would be so big). A milch camel will give so much milk that a whole party will be able to drink from it; a cow will give so much milk that a whole tribe will be able to drink from it; and a milch-sheep will give so much milk that a whole family will be able to drink from it. At that time, Allaah will send a pleasant wind which will soothe them even under their armpits, and will take the soul of every Muslim. Only the most wicked people will be left, and they will fornicate like asses; then the Last Hour will come upon them." "

[Muslim] [1]

Footnote

[1] Muslim, Kitaab al-Fitan wa Ashraat al-Saa'ah, 8/196-199.

Ludd: the biblical Lydda, now known as Lod, site of the zionist state's major airport

Hadeeth narrated from Abu Umaamah Al-Baahilee

Abu Umaamah al-Baahilee said,

"The Prophet (sal-Allaahu 'alayhe wa sallam) delivered a speech to us, most of which dealt with the Dajjaal and warned us against him. He said, 'No tribulation on earth since the creation of Adam will be worse than the tribulation of the Dajjaal. Allaah has never sent a Prophet who did not warn his Ummah against the Dajjaal. I am the last of the Prophets, and you are the last Ummah. The Dajjaal is emerging among you and it is inevitable. If he appears while I am still among you, I will contend with him on behalf of every Muslim. But if he appears after I am gone, then every person must contend with him on his own behalf. He will appear on the way between Syria and Iraq, and will spread disaster right and left. O servants of Allaah adhere to the path of Truth. I shall describe him for you in a way that no Prophet has ever done before.

He will start by saying that he is a Prophet, but there will be no Prophet after me. Then he will say, "I am your Lord," but you will never see your

Lord until you die. The Dajjaal is one-eyed, but your Lord, glorified be He, is not one-eyed. On his forehead will be written the word Kaafir, which every Muslim, literate or illiterate, will be able to read. Among that which he will bring will be the Paradise and Hell he will offer; but that which he calls Hell will be Paradise, and that which he calls Paradise will be Hell. Whoever enters his Hell, let him seek refuge with Allaah and recite the opening Ayaat of Surat ul-Kahf, and it will become cool and peaceful for him, as the fire became cool and peaceful for Abraham.

"He will say to a Bedouin, What do you think if I bring your father and mother back to life for you? Will you bear witness that I am your lord? The Bedouin will say Yes, so two devils will assume the appearance of his father and mother, and will say, "O my son, follow him for he is your lord."

"He will be given power over one person, whom he will kill and cut in two with a saw. Then he will say, Look at this slave of mine, now I will resurrect him, but he will still claim that he has a Lord other than me. Allaah will resurrect him, and this evil man (the Dajjaal) will say to him, Who is your Lord? The man will answer, 'My Lord is Allaah, and you are the enemy of Allaah. You are the Dajjaal. By Allaah, I have never been more sure of this than I am today.' "

Abou Sa'eed said,

"The Prophet (sal-Allaahu 'alayhe wa sallam) said, 'That man will have the highest status among my Ummah in Paradise.' "

Abu Sa'eed said,

"By Allaah, we never thought that that man would be any other than 'Umar ibn al-Khattab, until he passed away."

Al-Muhaaribee said:

"Then we referred to the Hadeeth of Abu Raafi'ee, which said, 'Part of his Fitnah will be the fact that he will pass through an area whose people will deny him, and none of their livestock will remain alive. Then he will pass through a second area whose people will believe in him; he will order the sky to rain and the earth to bring forth crops, and their flocks will return from grazing fatter than they have ever been, with their flanks stretched, their udders full. He will pass through every place on earth - except Makkah and Madeenah, which he will never enter, for there are angels guarding every gate of them with unsheathed swords - until he reaches al-Zareeb al-Ahmar and camps at the edge of the salt-marsh. Madeenah will be shaken by three tremors, after which every Munaafiq (hypocrite) will leave it, and it will be cleansed of evil, as iron is cleansed of dross. That day will be called Yawm al-Khalaas (The Day of Purification).' "

Umm Shareek bint Abee'l-'Akr said,
 "O Messenger of Allaah, where will the Arabs be at that time?" He said,
 "At that time they will be few; most of them will be in Bayt al-Maqdis (Jerusalem), and their Imaam will be a righteous man. Whilst their Imaam is going forward to lead the people in praying Salaat al-Subh (the morning prayer), Jesus son of Mary will descend. The Imaam will step back, to let Jesus lead the people in prayer, but Jesus will place his hand between the man's shoulders and say, 'Go forward and lead the prayer, for the Iqaamah was made for you.' So the Imaam will lead the people in prayer, and afterwards Jesus (alayhi-salam) will say, 'Open the gate.' The gate will be opened, and behind it will be the Dajjaal and a thousand Jews, each of them bearing a sword and shield. When the Dajjaal sees Jesus, he will begin to dissolve like salt in water, and will run away. Jesus will say, 'You will remain alive until I strike you with my sword.' He will catch up with him at the eastern gate of Ludd and will kill him. The Jews will be deflated with the help of Allaah. There will be no place for them to hide; they will not be able to hide behind any stone, wall, animal or tree - except the boxthorn (al-Gharqarah) - without it saying, 'O Muslim servant of Allaah! here is a Jew, come and kill him!' " The Prophet (sal-Allaahu 'alayhe wa sallam) said, "The time of the Dajjaal will be forty years; one year like half a year, one year like a month, and one month like a week. The rest of his days will pass so quickly that if one of you were at one of the gates of Madeenah, he would not reach the other gate before evening fell."

Someone asked,

"O Messenger of Allaah, how will we pray in those shorter days?" He said, "Workout the times of prayer in the same way that you do in these longer days, and then pray." The Prophet (sal-Allaahu 'alayhe wa sallam) said, "Jesus son of Mary will be a just administrator and leader of my Ummah. He will break the cross, kill the pigs, and abolish the Jizyah (tax on non-Muslims). He will not collect the Sadaqah, so he will not collect sheep and camels. Mutual enmity and hatred will disappear. Every harmful animal will be made harmless, so that a small boy will be able to put his hand into a snakes mouth without being harmed, a small girl will be able to make a lion run away from her, and a wolf will go among sheep as if he were a sheepdog. The earth will be filled with peace as a container is filled with water. People will be in complete agreement, and only Allaah will be worshipped. Wars will cease, and the authority of Quraysh will be taken away. The earth will be like a silver basin, and will produce fruits so abundantly that a group of people will gather to eat a bunch of grapes or

on pomegranate and will be satisfied. A bull will be worth so much money, but a horse will be worth only a few dirhams."

Someone asked,

"O Messenger of Allaah, why will a horse be so cheap?" He said,

"Because it will never be ridden in war." He was asked, "Why will the bull be so expensive?" He said, "Because it will plough the earth. For three years before the Dajjaal emerges, the people will suffer severe hunger. In the first year, Allaah will order the sky to withhold a third of its rain, and the earth to withhold two-thirds of its fruits. In the third year, He will order the sky to withhold all of its rain, and the earth to withhold all of its fruits, so that nothing green will grow. Every cloven-hoofed creature will die except for whatever Allaah wills." Someone asked, "How will the people live at that time?" He said, "By saying Laa ilaaha illaa Allaah, Allaahu Akbar, Subhaan Allaah and Al-Hamdu-lillaah. This will be like food for them." [1]

The Prophet (sal-Allaahu 'alayhe wa sallam) said,

"The Dajjaal will come forth, and one of the Believers will go towards him.

The armed men of the Dajjaal will ask him, 'Where are you going?' He will say, 'I am going to this one who has come forth.' They will say, 'Kill him!' Then some of them will say to the others, 'Hasn't your lord [ie the Dajjaal] forbidden you to kill anyone without his permission?' So they will take him to the Dajjaal, and when the Believer sees him, he will say, 'O People, this is the Dajjaal whom the Prophet (sal-Allaahu 'alayhe wa sallam) told us about.' Then the Dajjaal will order them to seize him and wound him in the head; they will inflict blows all over, even in his back and stomach. The Dajjaal will ask him, 'Don't you believe in me?' He will say, 'You are a false Messiah.' The Dajjaal will order that he be sawn in two from the parting of his hair to his legs; then he will walk between the two pieces. Then he will say 'Stand!' and the man will stand up. The Dajjaal will say to him, 'Don't you believe in me?' The believer will say, 'It has only increased my understanding that you are the Dajjaal.' Then he will say, 'O people! he will not treat anyone else in such a manner after me.' The Dajjaal will seize him to slaughter him, but the space between his neck and collar-bone will be turned into copper, and the Dajjaal will not be able to do anything to him. He will take the man by his arms and legs and throw him away; the people will believe that he has been thrown into Hell, whereas in fact he will have been thrown into Paradise." The Prophet (sal-Allaahu 'alayhe wa sallam) said, "He will be the greatest of martyrs in the sight of Allaah, the Lord of the Worlds." [Muslim] [2]

Footnotes

[1] Ibn Maajah, Kitaab al-Fitan, (Hadeeth 4077), 2:1363.

"He will break the cross and kill pigs", i.e. Christianity will be annulled.

"He will not collect the Sadaqah" (i.e. Zakaat) - because there will be so much wealth, and no-one will be in need of Sadaqah.

Checker's Note: Da`eef. Da`eef Ibn Maajah: 884. Parts are supported.

[2] Muslim, Kitaab al-Fitan wa Ashtaar al-Saa'ah, 8/199, 200

The Hadeeth of Al-Mugheerah Ibn Shu'bah

Al-Mugheerah ibn Shu'bah said,

"No-one asked the Prophet (sal-Allaahu 'alayhe wa sallam) more questions about the Dajjaal than I did. He said, 'You should not worry about him, because he will not be able to harm you.' I said, 'But they say that he will have much food and water!' He said, 'He is too insignificant in the sight of Allaah to have all that.' " [Muslim]

Al-Mugheerah ibn Shu'bah said,

"No-one asked the Prophet (sal-Allaahu 'alayhe wa sallam) more questions about the Dajjaal than I did." One of the narrators said, "What did you ask him?" Al-Mugheerah said, "I said, 'They say that the Dajjaal will have a mountain of bread and meat, and a river of water. The Prophet (sal-Allaahu 'alayhe wa sallam) said, 'He is too insignificant in the sight of Allaah to have all that.' " [Muslim]

From these Ahaadeeth, we can see that Allaah will test His servants with the Dajjaal and by the miracles which he will be permitted to perform: as we have already mentioned, the Dajjaal will order the sky to rain for those who accept him, and will order the earth to bring forth its fruits so that they and their livestock will eat of it, and their flocks will return fat and with their udders full of milk. Those who reject the Dajjaal and refuse to believe in him will suffer drought and famine; people and livestock will die, and wealth and supplies of food will be depleted. People will follow the Dajjaal like swarms of bees, and he will kill a young man and bring him back to life.

This is not a kind of magic; it will be something real with which Allaah will test His servants at the end of time. Many will be led astray, and many will be guided by it. Those who doubt will disbelieve, but those who believe will be strengthened in their faith.

Al-Qaadi 'Iyaad and others interpreted the phrase "He is too insignificant in the sight of Allaah to have all that" as meaning that the Dajjaal is too insignificant to have anything that could lead the true believers astray, because he is obviously evil and corrupt. Even if he brings great terror, the word Kaafir will be clearly written between his eyes; one report

explains that it will be written "Kaaf, Faa, Raa," from which we can understand that it will be written perceptibly, not abstractly, as some people say.

One of his eyes will be blind, protruding and repulsive; this is the meaning of the Hadeeth: "...as if it were a grape floating on the surface of the water." Other reports say that it is "dull, with no light in it," or "like white spittle on a wall," i.e. it will look ugly.

Some reports say that it is his right eye which will be blind; others say that it is his left eye.

He could be partly blind in both eyes, or there could be a fault in both eyes. This interpretation could be supported by the Hadeeth narrated by at-Tabaraanee, in which he reports that Ibn 'Abbaas said,

"The Prophet (sal-Allaahu 'alayhe wa sallam) said, 'The Dajjaal is curly-haired and white-skinned. His head is like the branch of a tree; his left eye is blind, and the other eye looks like a floating grape.' "

One may ask: if the Dajjaal is going to cause such widespread evil and his claim to be a "lord" will be so widely believed - even though he is obviously a liar, and all the Prophet's have warned against him - why does the Qur'aan not mention him by name and warn us against his lies and stubbornness?

The answer is:-

The Dajjaal was referred to in the Ayah:

"...The day that some of the Signs of your Lord do come, no good will it do to a person to believe then, if he believed not before, nor earned good (by performing deeds of righteousness) through his Faith..." [al-An'aam (6):158]

Abu Hurairah said,

"The Prophet (sal-Allaahu 'alayhe wa sallam) said, 'There are three things which, when they appear, no good will it do a soul to believe in them then, if it believed not before nor earned righteousness through its Faith. They are: The Dajjaal, the Beast, and the rising of the sun from the west.' "

Jesus son of Mary will descend from Heaven and kill the Dajjaal, as we have already mentioned. The descent of Jesus is mentioned in the Ayaat:

"And because of their saying (in boast), "We killed Messiah 'Eesaa (Jesus), son of Maryam (Mary), the Messenger of Allaah," - but they killed him not, nor crucified him, but the resemblance of 'Eesaa (Jesus) was put over another man (and they killed that man), and those who differ therein are full of doubts. They have no (certain) knowledge, they follow nothing but conjecture. For surely; they killed him not [i.e. 'Eesaa

(Jesus), son of Maryam (Mary) alayhi-salam]:

But Allaah raised him ['Eesaa (Jesus)] up (with his body and soul) unto Himself (and he alayhi-salam is in the heavens). And Allaah is Ever All Powerful, All Wise.

And there is none of the people of the Scripture (Jews and Christians), but must believe in him ['Eesaa (Jesus), son of Maryam (Mary), as only a Messenger of Allaah and a human being], before his ['Eesaa (Jesus) alayhi-salam or a Jew's or a Christian's] death (at the time of the appearance of the angel of death). And on the Day of Resurrection, he ['Eesaa (Jesus)] will be a witness against them." [an-Nisaa' (4):157-9] We think that the Tafseer (interpretation) of this Aayah is that the pronoun in "before his death" (qabla mawtihi) refers to Jesus; i.e, he will descend and the People of the Book who differed concerning him will believe in him. The Christians claimed that he was divine, while the Jews made a slanderous accusation, i.e. that he was born from adultery. When Jesus descends before the Day of Judgment, he will correct all these differences and lies.

On this basis, the reference to the descent of the Messiah Jesus son of Mary also includes a reference to the Dajjaal (false Mesor Antichrist), who is the opposite of the true Messiah, because sometimes the Arabs refer to one of two opposites and not the other, but mean both.

The Dajjaal is not mentioned by name in the Qur'aan because he is so insignificant: he claims to be divine, but he is merely a human being. His affairs are too contemptible to be mentioned in the Qur'aan. But the Prophet's, out of loyalty to Allaah, warned their people about the Dajjaal and the tribulations and misguiding miracles he would bring. It is enough for us to know the reports of the Prophet's and the many reports from the Prophet Muhammad (sal-Allaahu 'alayhe wa sallam).

One could argue that Allaah has mentioned Pharaoh and his false claims, such as:

"I am your lord, most high" [an-Nazi'aat (79):24] and "O chiefs! I know not that you have an ilaah (a god) other than me..." [al-Qasas (28):38]

This can be explained by the fact that Pharaoh and his deeds are in the past, and his lies are clear to every believer. But the Dajjaal is yet to come, in the future; it will be a Fitnah and a test for all people. So the Dajjaal is not mentioned in the Qur'aan because he is contemptible; and the fact that he is not mentioned means that it will be a great test.

The facts about the Dajjaal and his lies are obvious and do not need further emphasis. This is often the case when something is very clear. For example, when the Prophet (sal-Allaahu 'alayhe wa sallam) was

terminally ill, he wanted to write a document confirming that Abu Bakr would be the Khaleefah after him. Then he abandoned this idea, and said,

"Allaah and the believers will not accept anyone other than Abu Bakr." He decided not to write the document because he knew of Abu Bakr's high standing among the Sahaabah (Companions) and was sure that they would not choose anyone else. Similarly, the facts about the Dajjaal are so clear that they did not need to be mentioned in the Qur'aan.

Allaah did not mention the Dajjaal in the Qur'aan because He (subhaanahu wa ta'aala) knew that the Dajjaal would not be able to lead His true servants astray; he would only increase their faith, their submission to Allaah and His Messenger, their belief in the Truth, and their rejection of falsehood. For this reason the believer whom the Dajjaal overpowers will say, when he revives him,

"By Allaah, it has only increased my understanding that you are the one-eyed liar about whom the Prophet (sal-Allaahu 'alayhe wa sallam) spoke."

More Ahaadeeth about the Dajjaal

The Prophet (sal-Allaahu 'alayhe wa sallam) said,

"The Dajjaal will emerge in a land in the east called Khurasan. His followers will be people with faces like hammered shields." [1]

Asmaa' bint Yazeed al-Ansaariyyah said,

"The Prophet (sal-Allaahu 'alayhe wa sallam) said, 'During the three years just before the Dajjaal comes, there will be one year when the sky will withhold one third of its rain and the earth one-third of its fruits. In the second year the sky will withhold two-thirds of its rain, and the earth two-thirds of its fruits. In the third year the sky will withhold all of its rain, and the earth all of its fruits, and all the animals will die. It will be the greatest tribulation: the Dajjaal will bring a Bedouin and say to him, "What if I bring your camels to life for you? Will you agree that I am your lord?" The Bedouin will say "Yes." So devils will assume the forms of his camels, with the fullest udders and the highest humps. Then he will bring a man whose father and brother have died, and will ask him, "What do you think if I bring your father and brother back to life? Will you agree that I am your lord?" The man will say "Yes," so the devils will assume the forms of his father and brother.' Then the Prophet (sal-Allaahu 'alayhe wa sallam) went out for something, and then returned. The people were very concerned about what he had told them. He stood in the doorway and asked, 'What is wrong, Asma'? I said, 'O Messaenger of Allaah, you have terrified us with what you said about the Dajjaal.' He said, 'He will

certainly appear. If I am still alive, I will contend with him on your behalf; otherwise Allaah will take care of every Muslim on my behalf.' I said, 'O Messenger of Allaah, we do not bake our dough until we are hungry, so how will it be for the believers at that time?' The Prophet (sal-Allaahu 'alayhe wa sallam) said, 'The glorification of Allaah which suffices the people of Heaven will be sufficient for them.' " [2]

Abu Hurairah (radi-Allahu 'anhu) said,

"The Prophet (sal-Allaahu 'alayhe wa sallam) said, 'The Hour will not come until the Muslims fight the Jews and kill them. When a Jew hides behind a rock or a tree, it will say, "O Muslim, O servant of Allaah! There is a Jew behind me, come and kill him!" All the trees will do this except the box-thorn (al-Gharqad), because it is the tree of the Jews.' " [Ahmad] [3]

Footnotes

[1] Tirmidhee Abwaab al-Fitan, Hadeeth 2338, 6/465. Ibn Maajah, Kitaab al-Fitan, Hadeeth 4072, 1354, 2/1353, 1354. Ahmad, Musnad 1/7.

Checker's Note: Saheeh, Saheeh Ibn Maajah: 4072.

[2] Ahmad, Musnad, 6/455, 456.

Checker's Note: Da'eef, al-Mishkat, 1st checking: 5491. Its isnaad contains Sharh ibn Hawshab, who is weak.

[3] Muslim, Kitaab al-Fitan wa Ashraat al-Saa'ah, 8/388. Ahmad, Musnad, 2/417.

Protection Against The Dajjaal

1. Seeking refuge with Allaah from his tribulation.

It is proven in the Saheeh (authentic) Ahaadeeth that the Prophet (sal-Allaahu 'alayhe wa sallam) used to seek refuge with Allaah from the tribulation of the Dajjaal in his prayers, and that he commanded his Ummah to do likewise:

"Allaahumma innaa na'oodhu bika min 'adhaabi jahannam, wa min 'adhaabi 'l-qabr, wa min fitnatee 'l-mahyaa'i wa'l-mamaat, wa min fitnatee 'l-maseehi 'd-dajjaal."

"O Allaah! We seek refuge with You from the punishment of Hell, from the punishment of the grave, from the tribulations of life and death, and from the tribulation of the False Messiah (Dajjaal)." [1]

This Hadeeth was narrated by many Sahabah, including Anas, Abu Hurairah, 'Aa'ishah, Ibn 'Abbaas, and Sa'd (radi-Allaahu 'anhum).

2. Memorising certain Aayaat from Surat al-Kahf.

Al-Haafidh ad-Dhahabee said,

"Seeking refuge with Allaah from the Dajjaal is mentioned in many

Mutawaatir Ahaadeeth (those with numerous lines of narrators). One way of doing this is to memorise ten Ayaat from Surat al-Kahf."

Abul-Diraa reported that the Prophet (sal-Allaahu 'alayhe wa sallam) said, "Whoever memorises the first ten Aayaat of Surat al-Kahf will be protected from the Dajjaal." [Abu Daawood] [2]

3. Keeping away from the Dajjaal.

One way to be protected from the tribulation of the Dajjaal is to live in Madeenah or Makkah.

Abu Hurairah reported that the Prophet (sal-Allaahu 'alayhe wa sallam) said,

"There are angels standing at the gates of Madeenah; neither plague nor the Dajjaal can enter it." [Bukhaaree, Muslim]

Abu Bakr reported that the Prophet (sal-Allaahu 'alayhe wa sallam) said, "The terror caused by the Dajjaal will not enter Madeenah. At that time it will have seven gates; there will be two angels guarding every gate."

[Bukhaaree] [3]

Anas said,

"The Prophet (sal-Allaahu 'alayhe wa sallam) said, 'The Dajjaal will come to Madeenah, and he will find angels guarding it. Neither plague nor the Dajjaal will enter it, inshaa-Allaah.' " [Tirmidhee, Bukhaaree]

It has been proven in the Saheeh Ahaadeeth that the Dajjaal will not enter Makkah or Madeenah, because the angels will prevent him from entering these two places which are sanctuaries and are safe from him. When he camps at the salt-marsh (Sabkhah) of Madeenah, it will be shaken by three tremors - either physically or metaphorically - and every hypocrite will go out to join the Dajjaal. On that day, Madeenah will be cleansed of its dross and will be refined and purified; and Allaah knows best.

Footnotes

[1] Bukhaaree, Kitaab al-Janaa'iz, 2/124. Muslim, Kitaab al-Masaajid, 2/93.

[2] Muslim, Kitaab al-Musaafirun, 2/199. Abu Daawood, Kitaab al-Malaahim, (Hadeeth 4301), 11/401, 402.

[3] Bukhaaree, Baab Haram al-Madeenah, 1/28.

The Life And Deeds Of The Dajjaal

The Dajjaal will be a man, created by Allaah to be a test for people at the end of time. Many will be led astray through him, and many will be guided through him; only the sinful will be led astray.

Al-Haafidh Ibn 'Alee al-Aabaar wrote in his book of history (at-Taareekh)

that the Dajjaal's Kunyah (nickname or paternal title) would be Abu Yoosuf. [1]

Abu Bakrah said,

"The Prophet (sal-Allaahu 'alayhe wa sallam) said, 'The Dajjaal's parents will remain childless for thirty years, then a one-eyed child will be born to them. He will be very bad and will cause a great deal of trouble. When he sleeps, his eyes will be closed but his heart (or mind) will still be active.' Then he described his parents: 'His father will be a tall and bulky man, with a long nose like a beak; his mother will be a huge, heavy-breasted woman.' " [2]

Abu Bakrah said,

"We heard that a child had been born to some of the Jews in Madeenah. Az-Zubayr ibn al-'Awaam and I went see his parents, and found that they matched the description given by the Prophet (sal-Allaahu 'alayhe wa sallam). We saw the boy lying in the sun, covered with a blanket, murmuring to himself. We asked his parents about him, and they said, 'We remained childless for thirty years, then this one-eyed boy was born to us. He is very bad and causes a great deal of trouble.' When we went out, we passed the boy. He asked us, 'What were you doing?' We said, 'Did you hear us?' He said, 'Yes; when I sleep, my eyes are closed but my heart (mind) is still active.' That boy was Ibn Sayyaad." [Ahmad, Tirmidhee; this Hadeeth is not very strong] [3]

As we have already seen in the Saheeh Ahaadeeth, Maalik and others think that Ibn Sayyaad was not the Dajjaal; he was one of a number of "lesser dajjaals." Later he repented and embraced Islaam; Allaah knows best his heart and deeds.

The "greater" Dajjaal is the one mentioned in the Hadeeth of Faatimah bint Qays, which she narrated from the Prophet (sal-Allaahu 'alayhe wa sallam), from Tameem ad-Daaree, and which includes the story of the Jassaasah. The Dajjaal will be permitted to appear at the end of time, after the Muslims have conquered a Roman city called Constantinople. He will first appear in Isfahaan, in an area known as the Jewish quarter (al-Yahoodiyyah). He will be followed by seventy thousand Jews from that area, all of them armed. Seventy thousand Tatars and many people from Khuraasaan will also follow him. At first he will appear as a tyrannical king, then he will claim to be a prophet, then a lord. Only the most ignorant of men will follow him; the righteous and those guided by Allaah will reject him. He will start to conquer the world country by country, fortress by fortress, region by region, town by town; no place will remain unscathed except Makkah and Madeenah. The length of his stay

on earth will be forty days: one day like a year, one day like a month, one day like a week, and the rest of the days like normal days, i.e. his stay will be approximately one year and two and a half months. Allaah will grant him many miracles, through which whoever He wills will be astray, and the faith of the believers will be strengthened. The descent of Jesus son of Mary, the true Messiah, will happen at the time of the Dajjaal, the false messiah. He will descend to the minaret in the east of Damascus. The believers and true servants of Allaah will gather to support him, and the Messiah Jesus son of Mary will lead them against the Dajjaal, who at that time will be heading for Bayt al-Maqdis (Jerusalem). He will catch up with him at 'Aqabah 'Afeeq. The Dajjaal will runaway from him, but Jesus will catch up with him at the gate of Ludd, and will kill him with his spear just as he is entering it. He will say to him, "I have to deal you a blow; you cannot escape." When the Dajjaal faces him, he will begin to dissolve like salt in water. So Jesus will kill him with his spear at the gate of Ludd, and he will die there, as many Saheeh Ahaadeeth indicate.

Majma' ibn Jaariyah is reported to have said,

"I heard the Prophet (sal-Allaahu 'alayhe wa sallam) saying, 'The son of Mary will kill the Dajjaal at the gate of Ludd.' " [Tirmidhee] [4]

Footnotes

[1] Checker's Note: Reported as the saying of ash-Sha'bi. The reporter, Mujaahid ibn Sa'eed is weak.

[2] Checker's Note: Da`eef, al-Mishkat, 1st checking: 6445.

[3] Tirmidhee, Abwaab al-Fitan (Hadeeth 2350), 6/522, 523. Ahmad, Musnad, 5/40.

"When he sleeps, his eyes will be closed but his heart (or mind) will still be active" - means that his evil ideas will still come to him even while he is asleep.

Checker's Note: Da`eef due to Alee ibn Zaid ibn Jad'an.

[4] Tirmidhee, Abwaab al-Fitan (Hadeeth 2345), 6/513, 514.

Checker's Note: Saheeh, Saheeh at-Tirmidhee: 1829.

The Descent of Jesus at the End of Time

Abd Allaah ibn 'Amr said,

"The Prophet (sal-Allaahu 'alayhe wa sallam) said, 'The Dajjaal will appear in my Ummah, and will remain for forty - "I cannot say whether he meant forty days, forty months or forty years." - Then Allaah will send Jesus (alayhi-salam), the son of Mary, who will resemble 'Urwah ibn Mas'ood. He will chase the Dajjaal and kill him. Then the people will live for seven years during which there will be no enmity between any two

persons. Then Allaah will send a cold wind from the direction of Syria, which will take the soul of everyone who has the slightest speck of good or faith in his heart. Even if one of you were to enter the heart of a mountain, the wind would reach him there and take his soul. Only the most wicked people will be left; they will be as careless as birds, with the characteristics of beasts, and will have no concern for right and wrong. Satan will come to them in the form of man and will say, "Don't you respond?" They will say, "What do you order us to do?" He will order them to worship idols, and in spite of that they will have sustenance in abundance, and lead comfortable lives.

"Then the Trumpet will be blown, and everyone will tilt their heads to hear it. The first one to hear it will be a man busy repairing a trough for his camels. He and everyone else will be struck down. Then Allaah will send (or send down) rain like dew, and the bodies of the people (i.e. the dead) will grow out of it. Then the trumpet will be sounded again, and the people will get up and look around. Then it will be said, "O people, go to your Lord and account for yourselves." It will be said, "Bring out the people of Hell," and it will be asked, "How many are there?" - the answer will come: "Nine hundred and ninety-nine out of every thousand." "On that day a child will grow old and the shin will be laid bare." [al-Qalam (68):42] " [Muslim] [1]

Abu Hurairah said,

"The Prophet (sal-Allaahu 'alayhe wa sallam) said, 'The son of Mary will come down as a just leader. He will break the cross, and kill the pigs. Peace will prevail and people will use their swords as sickles. Every harmful beast will be made harmless; the sky will send down rain in abundance, and the earth will bring forth its blessings. A child will play with a fox and not come to any harm; a wolf will graze with sheep and a lion with cattle, without harming them.' " [Ahmad] [2]

Abu Hurairah said,

"The Prophet (sal-Allaahu 'alayhe wa sallam) said, 'By Him in Whose hand is my soul, surely the son of Mary will come down among you as a just ruler. He will break the cross, kill the pigs and abolish the Jizyah. Wealth will be in such abundance that no-one will care about it, and a single prostration in prayer will be better than the world and all that is in it.' "

Abu Hurairah said,

'If you wish, recite the Aayah: "And there is none of the People of the Book but must believe in him before his death; and on the Day of Judgement he will be a witness against them..." [an-Nisaa' (4):159] '

[Bukhaaree, Muslim] [3]

Abu Hurairah reported that the Prophet (sal-Allaahu 'alayhe wa sallam) said,

"The Prophets are like brothers; they have different mothers but their religion is one. I am the closest of all the people to Jesus son of Mary, because there is no other Prophet between him and myself. He will come again, and when you see him, you will recognise him. He is of medium height and his colouring is reddish-white. He will be wearing two garments, and his hair will look wet. He will break the cross, kill the pigs, abolish the Jizyah and call the people to Islaam. During his time, Allaah will end every religion and sect other than Islaam, and will destroy the Dajjaal. Then peace and security will prevail on earth, so that lions will graze with camels, tigers with cattle, and wolves with sheep; children will be able to play with snakes without coming to any harm. Jesus will remain for forty years, then die, and the Muslims will pray for him."

[Ahmad] [4]

Ibn Masood reported that the Prophet (sal-Allaahu 'alayhe wa sallam) said,

"On the night of the Israa' (night journey), I met my father Abraham, Moses and Jesus, and they discussed the Hour. The matter was referred first to Abraham, then to Moses, and both said, 'I have no knowledge of it.' Then it was referred to Jesus, who said, 'No-one knows about its timing except Allaah; what my Lord told me was that the Dajjaal will appear, and when he sees me he will begin to melt like lead. Allaah will destroy him when he sees me. The Muslims will fight against the Kaafirs, and even the trees and rocks will say, "O Muslim, there is a Kaafir hiding beneath me - come and kill him!" Allaah will destroy the Kaafirs, and the people will return to their own lands. Then Gog and Magog will appear from all directions, eating and drinking everything they find. The people will complain to me, so I will pray to Allaah and He will destroy them, so that the earth will be filled with their stench. Allaah will send rain which will wash their bodies into the sea. My Lord has told me that when that happens, the Hour will be very close, like a pregnant woman whose time is due, but her family do not know exactly when she will deliver.' "

[Ahmad, Ibn Maajah] [5]

Footnotes

[1] Muslim, Kitaab al-Fitan wa Ashraat al-Saa'ah, 8/201, 202.

[2] Ahmad, Musnad, 2/482, 483.

Checker's Note: The Tabi'e is Ziyad ibn Sa'd, who is mentioned by Ibn

Hibban in ath-Thiqat al-Bukhari and Abu Hatim did not speak for nor against him. Ibn Kathir says the report is good and strong.

[3] Bukhaaree, Kitaab al-Anbiyaa, 204, 205. Muslim, Kitaab al-Imaan, 1/93, 94.

[4] Ahmad, Musnad, 2/406.

Checker's Note: Saheeh as declared by al-Hakim and adh-Dhahabi.

Qatadah's hearing it is reported in a later narration in al-Musnad 2/436.

[5] Ahmad, Musnad, 1/375. Similar Hadeeth in Ibn Maajah, Kitaab al-Fitan (Hadeeth 4081), 2/1365, 1366.

Checker's Note: Da`eef, Da`eef al-Jami as-Sagheer: 4709. See Saheeh Muslim translation, no. 6924

Description of the Messiah Jesus son of Mary, Messenger of Allaah

Abu Hurairah said,

"The Prophet (sal-Allaahu 'alayhe wa sallam) said, 'On the night of the Israa' (miraculous journey to Jerusalem) I met Moses - he was a slim man with wavy hair, and looked like a man from the Shanoo'ah tribe. I also met Jesus - he was of medium height and of a red complexion, as if he had just come out of the bath' " [Bukhaaree, Muslim] [1]

The Prophet (sal-Allaahu 'alayhe wa sallam) said,

"Whilst I was asleep, I saw myself (in a dream) making Tawaaf around the Ka'bah. I saw a brown-skinned man, with straight hair, being supported by two men, and with water dripping from his head. I said, 'Who is this?' They said, 'The son of Mary' I turned around and saw a fat, ruddy man, with curly hair, who was blind in his right eye; his eye looked like a floating grape. I asked, 'Who is this?' They said, 'The Dajjaal.' The one who most resembles him is Ibn Qatan." Az-Zuhri explained: Ibn Qatan was a man from Khuzaa'ah who died during the Jaahiliyyah (before the coming of Islaam). [Bukhaaree] [2]

Footnotes

[1] Bukhaaree, Kitaab al-Anbiyaa, 4/302. Muslim, Kitaab al-Imaan, 1/106, 107.

[2] Bukhaaree, ibid.

The Appearance of Gog and Magog

They (two tribes or peoples) will appear at the time of Jesus son of Mary, after the Dajjaal. Allaah will destroy them all in one night, in response to the supplication of Jesus.

Abu Hurairah reported that the Prophet (sal-Allaahu 'alayhe wa sallam) said,

"Everyday, Gog and Magog are trying to dig a way out through the

barrier. When they begin to see sunlight through it, the one who is in charge of them says, 'Go back; you can carry on digging tomorrow,' and when they come back, the barrier is stronger than it was before. This will continue until their time comes and Allaah wishes to send them forth. They will dig until they begin to see sunlight, then the one who is in charge of them will say, 'Go back; you can carry on digging tomorrow, inshaa'-Allaah.' In this case he will make an exception by saying inshaa'-Allaah, thus relating the matter to the Will of Allaah. They will return on the following day, and find the hole as they left it. They will carry on digging and come out against the people. They will drink all the water, and the people will entrench themselves in their fortresses. Gog and Magog will fire their arrows into the sky, and they will fall back to earth with something like blood on them. Gog and Magog will say, 'We have defeated the people of earth, and overcome the people of heaven.' Then Allaah will send a kind of worm in the napes of their necks, and they will be killed by it..' 'By Him in Whose hand is the soul of Muhammad, the beasts of the earth will become fat.' " [1]

Gog and Magog are two groups of Turks, descended from Yaafith (Japheth), the father of the Turks, one of the sons of Noah. At the time of Abraham (alayhi-salam), there was a king called Dhu'l-Qarnayn. He performed Tawaaf around the Ka'bah with Abraham (alayhi-salam) when he first built it; he believed and followed him. Dhu'l-Qarnayn was a good man and a great king; Allaah gave him great power and he ruled the east and west. He held sway over all kings and countries, and travelled far and wide in both east and west. He travelled eastwards until he reached a pass between two mountains, through which people were coming out. They did not understand anything, because they were so isolated; they were Gog and Magog. They were spreading corruption through the earth, and harming the people, so the people sought help from Dhu'l-Qarnayn. They asked him to build a barrier between them and Gog and Magog. He asked them to help him to build it, so together they built a barrier by mixing iron, copper and tar.

Thus Dhu'l-Qarnayn restrained Gog and Magog behind the barrier. They tried to penetrate the barrier, or to climb over it, but to no avail. They could not succeed because the barrier is so huge and smooth. They began to dig, and they have been digging for centuries; they will continue to do so until the time when Allaah decrees that they come out. At that time the barrier will collapse, and Gog and Magog will rush out in all directions, spreading corruption, uprooting plants, killing people. When Jesus (alayhi-salam) prays against them, Allaah will send a kind of worm

in the napes of their necks, and they will be killed by it.

Footnotes

[1] Tirmidhee, Abwaab al-Tafsir: Soorat al-Kahf (Hadeeth 5160), 8/597-99. Ibn Maajah, Kitaab al-Fitan, (Hadeeth 4080), 2/1364. Ahmad, Musnad, 2/510, 511.

Checker's Note: Saheeh, Silsilatul Ahadeeth as-Saheehah: 1735.

The destruction of the Ka'bah

At the end of time, Dhu'l-Suwayqatayn, who will come from Abyssinia (al-Habash), will destroy the Ka'bah in order to steal its treasure and Kiswah (cloth covering). The Ka'bah is the ancient building which was built by Abraham, and whose foundations were laid by Adam.

As Tafseer (interpretation) of the Aayah "Until the Gog and Magog (people) are let through (their barrier)" [al-Anbiyaa' (21):96], it was reported from Ka'b al-Ahbar that Dhu'l-Suwayqatayn will first emerge at the time of Jesus, son of Mary. Allaah will send Jesus at the head of a vanguard of between seven and eight hundred. While they are marching towards Dhu'l-Suwayqatayn, Allaah will send a breeze from the direction of Yemen, which will take the soul of every believer. Only the worst of people will be left, and they will begin to copulate like animals. Ka'b said: "At that time, the Hour will be close at hand." [1]

'Abd Allaah ibn 'Amr said,

"I heard the Prophet (sal-Allaahu 'alayhe wa sallam) say, 'Dhu'l-Suwayqatayn from Abyssinia will destroy the Ka'bah and steal its treasure and Kiswah. It is as if I could see him now: he is bald-headed and has a distortion in his wrists. He will strike the Ka'bah with his spade and pick-axe.' " [Ahmad] [2]

It was reported from 'Abd Allaah ibn 'Umar that the Prophet (sal-Allaahu 'alayhe wa sallam) said,

"Leave the Abyssinians alone so long as they do not disturb you, for no-one will recover the treasure of the Ka'bah except Dhu'l-Suwayqatayn from Abyssinia." [Abu Daawood, in the chapter on the prohibition of provoking the Abyssinians] [3]

Ibn 'Abbaas narrated that the Prophet (sal-Allaahu 'alayhe wa sallam) said,

"It is as if I can see him now: he is black and his legs are widely spaced. He will destroy the Ka'bah stone by stone." [Ahmad] [4]

The Prophet (sal-Allaahu 'alayhe wa sallam) said,

"The Hour will not come until a man from Qahtaan appears and rules the people." [Muslim; similar Hadeeth in Bukhaaree]

This man could be Dhu'l-Suwayqatayn, or someone else, because this man comes from Qahtaan, while other reports say that Dhu'l-Suwayqatayn comes from Abyssinia; and Allaah knows best.

Abu Hurairah said,

"The Prophet (sal-Allaahu 'alayhe wa sallam) said, 'Day and night will not come to an end until a freed man called Jahjaah holds sway.'" [Ahmad] [5]

This could be the name of Dhul-Suwayqatayn from Abyssinia; and Allaah knows best.

'Umar ibn al-Khattab reported that he heard the Prophet (sal-Allaahu 'alayhe wa sallam) say:

"The people of Makkah will leave, and only a few people will pass through it. Then it will be resettled and rebuilt; then the people will leave it again, and no-one will ever return." [6]

Footnotes

[1] Concerning Dhu'l-Suwayqatayn, see: Bukhaaree: Kitaab al-Hajj, Baab Hadam al-Ka'bah (The Book of Pilgrimage, Chapter of the Destruction of the Ka'bah), 2/183. Muslim, Kitaab al-Fitan wa Ashraat al-Saa'ah, 8/183. Dhu'l-Suwayqatayn: al-Suwayqatayn is the diminutive of al-Saaqayn (legs); his legs are described as being "small" because they are thin. Thin legs are, in general, a characteristic of the Sudanese and people of the Horn of Africa.

[2] Ahmad, Musnad, 2/220.

Checker's Note: Da`eef isnaad. It contains the `an`anah of Abu Zubair. The first part, up to 'treasure' is hasan, Silsilatul Ahadeeth as-Saheehah: 771.

[3] Abu Daawood, Kitaab al-Malaahim, (Hadeeth 4287), 11/423.

Checker's Note: Hasan, Saheeh Abee Daawood.

[4] Ahmad, Musnad, 1/227.

Checker's Note: Saheeh, also reported in al-Bukhaaree.

[5] Checker's Note: Saheeh, Ahmad, Muslim and at-Tirmidhee. Silsilatul Ahadeeth as-Saheehah: 7684.

[6] Ahmad, Musnad, 1/23.

Checker's Note: Da`eef, Da`eef al-Jami as-Sagheer: 3298. Da`eef due to Ibn Lahi'ah and `an`anah of Abu Zubair

Madeenah will remain inhabited at the time of the Dajjaal

It has been proven in the Saheeh Ahaadeeth, as already stated, that the Dajjaal will not be able to enter Makkah and Madeenah, and that there will be angels at the gates of Makkah to ward him off and prevent him

from entering.

It was reported from Abu Hurairah that the Prophet (sal-Allaahu 'alayhe wa sallam) said,

"Neither the Dajjaal nor plague will be able to enter Madeenah."

As mentioned above, the Dajjaal will camp outside Madeenah, and it will be shaken by three tremors. Every hypocrite and sinner will go out to join the Dajjaal, and every believer and Muslim will stay. That day will be called the Day of Purification (Yawm al-Khalaas). Most of those who go out to join the Dajjaal will be women. As the Prophet (sal-Allaahu 'alayhe wa sallam) said,

"Verily it (Madeenah) is good; its evil will be eliminated and its goodness will be obvious."

Allaah (subhaanahu wa ta'aala) said:

"Women impure are for men impure, and men impure for women impure, and women of purity are for men of purity, and men of purity are for women of purity..." [an-Noor (24):26]

Madeenah will remain inhabited during the days of the Dajjaal, and during the time of Jesus son of Mary (alayhi-salam), until he dies and is buried there. Then it will be destroyed.

'Umar ibn al-Khattab said,

"I heard the Prophet (sal-Allaahu 'alayhe wa sallam) say, 'A rider will go around Madeenah and say, There used to be many Muslims here.' "

[Ahmad] [1]

Footnotes

[1] Ahmad, Musnad, 1/20.

Checker's Note: Da'eef isnaad due to Ibn Lahi'ah and `an`anah of Abu Zubair. The fact that Madinah will be deserted is reported from Abu Hurairah by al-Bukhaaree.

The Emergence of the Beast

Among the signs of the Hour will be the emergence of a beast from the earth. It will be very strange in appearance, and extremely huge; one cannot even imagine what it will look like. It will emerge from the earth and shake the dust from its head. It will have with it the ring of Solomon and the rod of Moses. People will be terrified of it and will try to run away, but they will not be able to escape, because such will be the decree of Allaah. It will destroy the nose of every unbeliever with the rod, and write the word "Kaafir" on his forehead; it will adorn the face of every believer and write the word "Mu'min" (true believer) on his forehead, and it will speak to people.

Allaah (subhaanahu wa ta'aala) said:

"And when the Word is fulfilled against them (the unjust), We shall produce from the earth a Beast to (face) them: it will speak to them..."

[an-Naml (27):82]

Ibn 'Abbaas, al-Hasan and Qataadah said that "It will speak to them" (tukallimuhum) means that it will address them. Ibn Jareer suggested that it means that the Beast will address them with the words "...for that mankind did not believe with assurance in Our Signs..." [an-Naml (27):82 - latter part of the Ayah]

Ibn Jareer reported this from 'Alee and 'Ata'. It was reported from Ibn 'Abbaas that tukallimuhum means that the Beast will cut them, i.e., it will write the word "Kaafir" on the forehead of the unbeliever. It was also reported from Ibn 'Abbaas that he will both address them and cut them; this suggestion incorporates both of the previous suggestions; and Allaah knows best.

We have already mentioned the Hadeeth of Hudhayfah ibn Usayd, in which the Prophet (sal-Allaahu 'alayhe wa sallam) is reported to have said,

"The Hour will not come until you see ten signs: the smoke; the Dajjaal; the Beast; the sun rising from the West; the descent of Jesus son of Mary; Gog and Magog; and three land-slides - one in the East, one in the West, and one in Arabia, at the end of which fire will burst forth from the direction of Aden (Yemen) and drive people to the place of their final assembly."

Abu Hurairah said,

"The Prophet (sal-Allaahu 'alayhe wa sallam) said, 'Hasten to do good deeds before six things happen: the rising of the sun from the West, the smoke, the Dajjaal, the Beast, the (death) of one of you or general tribulation.' " [Muslim]

Bareedah said,

"The Prophet (sal-Allaahu 'alayhe wa sallam) took me to a place in the desert, near Makkah. It was a dry piece of land surrounded by sand. The Prophet (sal-Allaahu 'alayhe wa sallam) said, 'The Beast will emerge from this place.' It was a very small area." [Ibn Maajah] [1]

It was reported from Abu Hurairah that the Prophet (sal-Allaahu 'alayhe wa sallam) said,

"The Beast of the Earth will emerge, and will have with it the rod of Moses and the ring of Solomon."

It was also reported that he said,

"(The Beast) will destroy the noses of the unbelievers with the ring, - so

that people seated around one table will begin to address one another with the words "O Believer!" or "O Unbeliever!" (i.e., everyone's status will become clear) [Ibn Maajah] [2]

'Abd Allaah ibn 'Amr said,

"I memorised a Hadeeth from the Prophet (sal-Allaahu 'alayhe wa sallam) which I have not forgotten since. I heard the Prophet (sal-Allaahu 'alayhe wa sallam) say, 'The first of the signs (of the Hour) to appear will be the rising of the sun from the West and the appearance of the Beast before the people in the forenoon. Whichever of these two events happens first, the other will follow immediately.' " [Muslim] [3]

That is to say, these will be the first extraordinary signs. The Dajjaal, the descent of Jesus (alayhi-salam), the emergence of Gog and Magog, are less unusual in that they are all human beings. But the emergence of the Beast, whose form will be very strange, its addressing the people and classifying them according to their faith or unbelief, is something truly extraordinary. This is the first of the earthly signs, as the rising of the sun from the West is the first of the heavenly signs.

Footnotes

[1] Ibn Maajah, Kitaab al-Fitan, (Hadeeth 4267), 2/1352.

Checker's Note: Da`eef Jiddan (very weak). Ibn Maajah, no. 4067, Da`eef Ibn Maajah: 882.

[2] Similar Hadeeth narrated by Ibn Maajah in Kitaab al-Fitan, (Hadeeth 4061), 2 - 1351, 1352. Ahmad, Musnad, 2 - 295.

Checker's Note: Da`eef, Da`eef al-Jami as-Sagheer: 2413.

[3] Muslim, Kitaab al-Fitan, 8/202.

The Rising of the Sun from the West

Allaah (subhaanahu wa ta'aala) says:

"Do they then wait for anything other than that the angels should come to them, or that your Lord should come, or that some of the Signs of your Lord should come (i.e. portents of the Hour e.g., arising of the sun from the west)! The day that some of the Signs of your Lord do come, no good will it do to a person to believe then, if he believed not before, nor earned good (by performing deeds of righteousness) through his Faith. Say:

'Wait you! we (too) are waiting.'" [al-An'aam (6):158]

It was reported from Abu Sa'eed al-Khudree that the Prophet (sal-Allaahu 'alayhe wa sallam) explained,

"The day that some of the Signs of your Lord do come, no good will it do to a person to believe then...", referring to the rising of the sun from the West. [Ahmad] [1]

Abu Hurairah said,

"The Prophet (sal-Allaahu 'alayhe wa sallam) said, 'The Hour will not come until the sun rises from the West. When the people see it, whoever is living on earth will believe, but that will be the time when - No good will it do to a person to believe then, if he believed not before then' "

[Bukhaaree] [2]

It was also reported from Abu Hurairah that the Prophet (sal-Allaahu 'alayhe wa sallam) said,

"The Hour will not come until the sun rises from the West. When it rises and the people see it, they will all believe. But that will be the time when 'No good will it do to a person to believe then.' " [Bukhaaree] [3]

It was reported from Abu Hurairah that the Prophet (sal-Allaahu 'alayhe wa sallam) said,

"There are three things which, if they appear, 'No good will it do to a person to believe then, if he believed not before, nor earned good (by performing deeds of righteousness) through his Faith' They are: the rising of the sun from the West, the Dajjaal, and the Beast of the Earth."

[Ahmad, Muslim, Tirmidhee] [4]

Abu Dharr said,

"The Prophet (sal-Allaahu 'alayhe wa sallam) asked me, 'Do you know where the sun goes when it sets?' I said, 'I do not know' He said, 'It travels until it prostrates itself beneath the Throne, and asks for permission to rise again. But a time will come when it will be told, 'Go back whence you came.' That will be the time when 'No good will it do to a person to believe then, if he believed not before, nor earned good (by performing deeds of righteousness) through his Faith' " [Bukhaaree] [5]

'Amr ibn Jareer said,

"Three Muslims were sitting with Marwaan in Madeenah, and heard him say, whilst talking about the Signs of the Hour, that the first of them would be the appearance of the Dajjaal. The three went to 'Abd Allaah ibn 'Amr, and told him what they had heard Marwaan say concerning the Signs. 'Abd Allaah said, 'Marwan has not said much. I memorised a Hadeeth like that from the Prophet (sal-Allaahu 'alayhe wa sallam) which I have not forgotten since. I heard the Prophet (sal-Allaahu 'alayhe wa sallam) say:

"The first of the signs will be the rising of the sun from the West, and the emergence of the Beast in the forenoon. Whichever of the two comes first, the other will follow immediately"

Then 'Abd Allaah, who was widely-read, said,

"I think that the first to happen will be the rising of the sun from the West.

Every time it sets, it goes beneath the Throne, prostrates itself, and seeks permission to rise again. A time will come when three times it will seek permission and will receive no reply, until, when part of the night has passed and it realises that even if it were given permission, it would not be able to rise on time, it will say: 'O my Lord, how far the rising-point is from me! What can I do for the people now?' Then it will seek permission to go back, and it will be told: 'Rise from where you are now' - and it will rise from the West." Then 'Abd Allaah recited the Aayah: "No good will it do to a person to believe then, if he believed not before, nor earned good (by performing deeds of righteousness) through his Faith." [Ahmad] [6]

Footnotes

[1] Ahmad, Musnad, 3/31.

Checker's Note: Saheeh, Saheeh at-Tirmidhee: 2455.

[2] Bukhaaree, Kitaab al-Tafsir, 6/73.

[3] Bukhaaree, ibid.

[4] Muslim, Kitaab al-Imaan, 1/96. Tirmidhee, Abwaab al-Tafsir (Hadeeth 5067), 8/449, 450. Ahmad, Musnad, 2/455, 446.

[5] Similar Hadeeth in Bukhaaree, Kitaab Bid' al-Khalq, 4/131.

[6] Ahmad, Musnad, 2/201.

Checker's Note: Saheeh, Musnad Imaam Ahmad, checking by Ahmad Shakir: 6881.

The Smoke which will appear at the End of Time

Masrooq said:

"While a man was giving a speech among the people of Kindah, he said, 'There will be smoke on the Day of Resurrection which will deprive the hypocrites of their hearing and sight, but the believers will only suffer something like a cold.' We were terrified, so we went to Ibn Masood, who was reclining. When he heard about this, he became angry and sat up, and said: 'O people, whoever knows a thing, let him say it; but whoever does not know, let him say, "Allaah knows best." It is a part of knowledge, when one does not know something, to say "Allaah knows best." Allaah (subhaanahu wa ta'aala) said to His Prophet Muhammad (sal-Allaahu 'alayhe wa sallam):

"Say (O Muhammad sal-Allaahu 'alayhe wa sallam): 'No wage do I ask of you for this (the Qur'aan), nor am I one of the Mutakallifoon (those who pretend and fabricate things which do not exist).'" [Saad (38):86]

"Quraysh were being slow in embracing Islaam, so the Prophet (sal-Allaahu 'alayhe wa sallam) prayed against them, saying, 'O Allaah, help

me against them by sending seven years of famine like those of Joseph.' They were afflicted by a year of famine in which they were destroyed, and ate dead animals and bones. They began to see something like smoke between the sky and the earth. Abu Sufyan came and said, 'O Muhammad! You came to command us to keep good relations with our relatives, and your people have perished, so pray that Allaah may relieve them.'"

Then Ibn Mas'ood recited,

"Then wait you for the Day when the sky will bring forth a visible smoke. Covering the people, this is a painful torment. (They will say): "Our Lord! Remove the torment from us, really we shall become believers!" How can there be for them an admonition (at the time when the torment has reached them), when a Messenger explaining things clearly has already come to them. Then they had turned away from him (Messenger Muhammad sal-Allaahu 'alayhe wa sallam) and said: "One (Muhammad sal-Allaahu 'alayhe wa sallam) taught (by a human being), a madman!" Verily, We shall remove the torment for a while. Verily! You will revert." [ad-Dukhaan (44):10-15]

Ibn Masood asked:

"Will their punishment in the Hereafter be removed so they can go back to their Kufr?"

Allaah (subhaanahu wa ta'aala) said:

"On the Day when We shall seize you with the greatest grasp. Verily, We will exact retribution." [ad-Dukhaan (44):16]

...and soon will come the inevitable (punishment)!" [al-Furqaan (25):77]

These Ayaat refer to the Day (Battle) of Badr. Allaah (subhaanahu wa ta'aala) said:

"Alif Laam Meem. The Romans have been defeated. In the nearer land (Syria, Iraq, Jordan, and Palestine), and they, after their defeat, will be victorious. Within three to nine years." [ar-Room (30): 1-4] [Bukhaaree] [1]

This speaker's suggestion - that the idea that the smoke would be on the Day of Resurrection was not a good one - made Ibn Masood react angrily. But the smoke will appear before the Day of Resurrection; it will be one of the signs, which are: the Beast, the Dajjaal, the Smoke, and Gog and Magog, as the Ahaadeeth narrated from Abu Sareehah, Abu Hurairah and other Sahaabah indicate.

As mentioned in the Saheeh Ahaadeeth, the fire which will appear before the Day of Resurrection will burst forth from the direction of Aden, and drive the people to the place of their final assembly. It will move with

them and halt with them, and will devour any who lag behind.

Footnote

[1] Bukhaaree, Kitaab at-Tafsir - Soorat ar-Room, 6/142, 143

Other Events which will precede the Hour

It was reported from Abu Sa'eed al-Khudree that the Prophet (sal-Allaahu 'alayhe wa sallam) said,

"Thunderbolts will increase so much as the Hour approaches that when a man comes to a people, he will ask, 'Who amongst you was struck by a thunderbolt this morning?' and they will say, 'So-and-so and so-and-so was struck.' " [Ahmad] [1]

Heavy rain before the Day of Resurrection

It was reported from Abu Hurairah that the Prophet (sal-Allaahu 'alayhe wa sallam) said,

"The hour will not come until there has been rain which will destroy all dwellings except tents." [2]

We have already mentioned many Ahaadeeth about the signs of the Hour. Now we will turn our attention to some Ahaadeeth which could indicate that the Hour is close at hand.

It was reported from Abu Hurairah that the Prophet (sal-Allaahu 'alayhe wa sallam) said:

"The Hour will not come until the following events have come to pass: people will compete with one another in constructing high buildings; two big groups will fight one another, and there will be many casualties - they will both be following the same religious teaching; earthquakes will increase; time will pass quickly; afflictions and killing will increase; nearly thirty dajjals will appear, each of them claiming to be a messenger from Allaah; a man will pass by a grave and say, 'Would that I were in your place'; the sun will rise from the West; when it rises and the people see it, they will all believe, but that will be the time when 'No good will it do to a person to believe then, if it believed not before...' [al-An'aam (6):158]; and a wealthy man will worry lest no-one accept his Zakaat." [Bukhaaree, Muslim]

It was reported from Anas that the Prophet (sal-Allaahu 'alayhe wa sallam) said:

"Among the signs of the Hour are the following: knowledge will decrease and ignorance will prevail; fornication and the drinking of wine will be common; the number of men will decrease and the number of women will increase, until one man will look after fifty women." [Bukhaaree] [3]
'Aa'ishah said,

"I heard the Prophet (sal-Allaahu 'alayhe wa sallam) say, 'Day and night will not pass away until people begin to worship Laat and 'Uzzaa' (two goddesses of pre-Islaamic Arabic). I said, 'O Messenger of Allaah, I thought that when Allaah revealed the Aayah "It is He Who has sent His Messenger (Muhammad sal-Allaahu 'alayhe wa sallam) with guidance and the religion of truth (Islaam), to make it superior over all religions even though the Mushrikoon (polytheists, pagans, idolaters, disbelievers in the Oneness of Allaah) hate (it)" [at-Tawbah (9):33], it implied that (this promise) would be fulfilled.' The Prophet (sal-Allaahu 'alayhe wa sallam) said, 'It will happen as Allaah wishes. Then Allaah will send a pleasant breeze, which will take everyone who has as much faith as a grain of mustard-seed in his heart. Only those with no goodness in them will be left, and they will revert to the religion of their forefathers.' " [Muslim] [4]

It was reported from Abu Hurairah that one day, while the Prophet (sal-Allaahu 'alayhe wa sallam) was sitting with the people, a Bedouin came to him and asked him about Eemaan and Islaam, then he asked, "O Messenger of Allaah, when will the Hour be?" He said, "The one who is asked about it does not know more than the one who asks, but I tell you about its signs. When a slave gives birth to her mistress, and when the bare-footed and naked become the chiefs of the people - these are among the signs of the Hour. There are five things which no-one knows except Allaah." Then he recited:

"Verily the knowledge of the Hour is with God (alone). It is He Who sends down rain, and He Who knows what is in the wombs. Nor does anyone know what it is that he will earn on the morrow: nor does anyone know in what land he is to die. Verily God is All-Knowing, All Aware." [Luqman (31):34]

Then the man went away, and the Prophet (sal-Allaahu 'alayhe wa sallam) said, "Call him back to me," but when the people went to call him, they could not see anything. The Prophet (sal-Allaahu 'alayhe wa sallam) said, "That was Gabriel, who came to teach the people their religion." [Bukhaaree, Muslim] [5]

"The bare-footed and naked paupers will compete with one another in constructing high buildings" means that they will become the chiefs of people. They will become rich, and their only concern will be to compete in constructing high buildings. This is as in the Hadeeth we shall see later:

"The Hour will not come until the happiest people in the world will be the depraved sons of the depraved."

It was reported from Abu Sa'eed that the Prophet (sal-Allaahu 'alayhe wa

sallam) said:

"The Hour will not come until the time when a man will leave his home, and his shoes or whip or stick will tell what is happening to his family."

[Ahmad] [6]

It was reported from Abu Sa'eed that the Prophet (sal-Allaahu 'alayhe wa sallam) said:

"By Him in Whose hand is my soul, the Hour will not come until wild animals talk to men, and a man speaks to his whip or his shoe, and his thigh will tell him about what happened to his family after he left." [7]

Anas said,

"We were discussing the fact that the Hour would not come until there is no rain, the earth does not produce crops, and fifty women will be cared for by one man; and if a woman passes by a man, he will look at her and say, 'This woman once had a husband.' " [Ahmad] [8]

Abu Hurairah said:

"The Prophet (sal-Allaahu 'alayhe wa sallam) said: 'The Hour will not come until time passes so quickly that a year will be like a month, a month like a week, a week like a day, a day like an hour, and an hour like the time it takes for a palm-leaf to burn.' " [Ahmad] [9]

Abu Hurairah said,

"The Prophet (sal-Allaahu 'alayhe wa sallam) said: 'The world will not pass away until the one who enjoys it the most is the depraved son of the depraved.' " [Ahmad] [10]

Abu Hurairah said,

"The Prophet (sal-Allaahu 'alayhe wa sallam) said, 'Before the Hour comes, there will be years of deceit, in which a truthful person will be disbelieved and a liar will be believed; and the insignificant will have a say.' " [Ahmad] [11]

Abu Hurairah said:

"I heard the Prophet (sal-Allaahu 'alayhe wa sallam) say: 'The Hour will not come until the sheep with horns no longer fights the sheep without horns.' " [Ahmad] [12]

It was reported from Abu Hurairah that the Prophet (sal-Allaahu 'alayhe wa sallam) said,

"The Hour will not come until wealth increases so much that a wealthy man will be worried lest no-one accept his Sadaqah; knowledge will be taken away; time will pass quickly; tribulations will appear; and there will be much Harj." The people asked, "What is Harj, O Messenger of Allaah?" He said, "Killing, killing." [Ahmad] [13]

It was reported from Abu Hurairah that the Prophet (sal-Allaahu 'alayhe

wa sallam) said,

"By Him Who sent me with the Truth, this earth will not pass away until people are afflicted with landslides, are pelted with stones, and are transformed into animals." The people asked, "When will that be, O Messenger of Allaah?" He said, "When you see women riding in the saddle, when singers are common, when bearing false witness becomes widespread, and when men lie with men and women with women." [14]

Taariq ibn Shihaab said,

"We were sitting with 'Abd Allaah ibn Mas'ood, when a man came and told us that the time for prayer had come. So we got up and went to the mosque... After the prayer, a man came to 'Abd Allaah ibn Mas'ood and said, 'As-salaam 'alayka (Peace be upon you), O Abu 'Abd ar-Rahmaan'. 'Abd Allaah answered, 'Allaah and His Messenger have spoken the truth.' When we went back, we asked one another, 'Did you hear the answer he gave? Who is going to ask him about it?' I said, 'I will ask him'; so I asked him when he came out. He narrated from the Prophet (sal-Allaahu 'alayhe wa sallam):

'Before the Hour comes, there will be a special greeting for the people of distinction; trade will become so widespread that a woman will help her husband in business; family ties will be cut; the giving of false witness will be common, while truthful witness will be rare; and writing will be widespread.' [Ahmad] [15]

Footnotes

[1] Ahmad, Musnad, 3/64, 65.

Checker's Note: Da'eef isnaad due to Muhammad ibn Mus'ab.

[2] Ahmad, Musnad, 2/262.

Checker's Note: Saheeh, Musnad Imaam Ahmad, checking by Ahmad Shakir: 7554 and Majma' az-Zawaid of al-Haythamee: 7/331.

[3] Bukhaaree, Kitaab al-'Ilm, 1/30, 31.

[4] Muslim, Kitaab al-Fitan 8/182.

[5] Bukhaaree, Kitaab al-Imaan, 1/19; Kitaab at-Tafsir - Soorat Luqmaan, 6/144. Muslim, Kitaab al-Imaan, 1/30, 31.

[6] Ahmad, Musnad, 3/88, 89.

Checker's Note: Saheeh.

[7] Ahmad, Musnad, 3/82, 84.

Checker's Note: Saheeh, Silsilatul Ahadeeth as-Saheehah: 122.

[8] Ahmad, Musnad, 3/286.

Checker's Note: Saheeh, reported by Ahmad, Abu Ya'la and al-Bazzar. Majma' az-Zawa'id of al-Haythamee: 7/333 and Kashful Astar bi Zawa'id

al-Bazzar of al-Haythamee: 3415.

[9] Ahmad, Musnad, 3/358.

Checker's Note: Saheeh, Saheeh al-Jami as-Sagheer: 7422.

[10] Ahmad, Musnad, 2/358.

Checker's Note: Saheeh, Saheeh al-Jami as-Sagheer: 7272.

[11] Ahmad, Musnad, 2/238.

Checker's Note: Hasan, Silsilatul Ahadeeth as-Saheehah: 1887.

[12] Ahmad, Musnad, 2/442.

Checker's Note: Da`eef?? [not quite sure] due to as-Salt ibn Quwaid; an-Nasaa'ee said, "His hadith is munkar."

[13] Ahmad, Musnad, 2/313.

Checker's Note: Saheeh, Musnad Imaam Ahmad, checking by Ahmad Shakir: 8120, 8121.

[14] al-Haythamee, Kitaab al-Fitan.

Checker's Note: Da`eef, related by al-Bazzar and at-Tabaraanee in al-Awsat. It is weak due to Sulaiman ibn Daawood al-Yamami who is matrook (abandoned). Majma' az-Zawa'id of al-Haythamee.

[15] Ahmad, Musnad, 1/407.

Checker's Note: Saheeh, Silsilatul Ahadeeth as-Saheehah: 648.

Description of the People who will be Alive at the End of Time

It was reported from 'Abd Allaah ibn 'Amr that the Prophet (sal-Allaahu 'alayhe wa sallam) said,

"The Hour will not come until Allaah takes away the best people on earth; only the worst people will be left; they will not know any good or forbid any evil." [Ahmad] [1]

'Abd Allaah ibn Mas'ood said,

"I heard the Prophet (sal-Allaahu 'alayhe wa sallam) say: 'Eloquence can be bewitching; the worst of the people are those upon whom the Hour will come while they are still alive, and those who turn graves into mosques.'"

[Ahmad] [2]

It was reported from Anas that the Prophet (sal-Allaahu 'alayhe wa sallam) said,

"The Hour will not come until no-one on earth says 'Laa ilaaha illaa Allaah.'" [Ahmad] [3]

It was also reported from Anas that the Prophet (sal-Allaahu 'alayhe wa sallam) said:

"The Hour will not come until no-one on earth says, 'Allaah, Allaah.'" [Ahmad] [4]

[Ahmad] [4]

There are two suggestions as to the meaning of the phrase, "until no-one on earth says 'Allaah, Allaah'":

It could mean that no-one will forbid evil, or try to correct another if he sees him doing something wrong. We have already come across this in the Hadeeth of 'Abd Allaah ibn 'Amr:

"Only the worst people will be left; they will not know any good or forbid any evil."

It could mean that Allaah will no longer be mentioned, and His Name will not be known; this will be part of the prevalent corruption and Kufr, as in the previous Hadeeth,

"Until no-one on earth says 'Laa ilaaha illaa Allaah."

'Aa'ishah said,

"The Prophet (sal-Allaahu 'alayhe wa sallam) came in, saying 'O 'Aa'ishah, your people will be the first of my Ummah to join me.' When he sat down, I said, 'O Messenger of Allaah, may I be sacrificed for you! When you came in, you were saying something which scared me.' He asked, 'What was that?' I said, 'You said that my people would be the first of your Ummah to join you.' He said, 'Yes.' I asked, 'Why is that?' He said, 'Death will be widespread among them, and their relatives will be jealous of them.' I said, 'How will people be after that?' He said, 'Like locusts: the strong will devour the weak, until the Hour comes.' " [Ahmad] [5]

'Albaa' al-Salamee said,

"I heard the Prophet (sal-Allaahu 'alayhe wa sallam) say: 'The Hour will only come upon the worst of the people.' " [Ahmad] [6]

Footnotes

[1] Ahmad, Musnad, 1/454.

Checker's Note: Da'eef isnaad due to `an`anah of al-Hasan al-Basree.

[2] Ahmad, Musnad, 3/268.

Checker's Note: Saheeh, Musnad Imaam Ahmad, checking by Ahmad Shakir: 4342.

[3] Ahmad, Musnad, 3/268.

Checker's Note: Saheeh, Tahdheerus Saajid of Shaykh al-Albaanee, pg. 119.

[4] Ahmad, Musnad, 3/107.

Checker's Note: Saheeh, Saheeh al-Jami as-Sagheer: 7420.

[5] Ahmad, Musnad, 6/81.

Checker's Note: Saheeh, Silsilatul Ahadeeth as-Saheehah: 1953.

[6] Ahmad, Musnad, 3/499.

Checker's Note: Saheeh, Mustadrak of al-Hakim: 4/496. Declared saheeh by al-Hakim and agreed to by adh-Dhahaabee

THE SIGNS BEFORE THE DAY OF JUDGEMENT

Author: Al-Haafidh Ibn Katheer Hadeeth Checking: Abu Talhah Daawood
Burbank

41

www.hcis.tk



www.harrowcollege.tk